



PL-2303X Edition USB to Serial Bridge Controller Product Datasheet

Document Revision: 1.4

Document Release: October, 2004

Prolific Technology Inc.

7F, No. 48, Sec. 3, Nan Kang Rd.

Nan Kang, Taipei 115, Taiwan, R.O.C.

Tel: 886-2-2654-6363 / Fax: 886-2-2654-6161

Email: sales@prolific.com.tw

URL: <http://www.prolific.com.tw>



Revision History

Revision	Description	Date
1.4	<ul style="list-style-type: none"> ➤ Modify the QFN Pin Diagram. ➤ Correct some typo errors. 	October 20, 2004
1.3	<ul style="list-style-type: none"> ➤ Added Pin 13 and Pin 14 descriptions ➤ Correct Min. Operating Voltage from 4.75 to 4.4V. 	October 19, 2004
1.2	<ul style="list-style-type: none"> ➤ Added QFN Package Pin Assignment 	June 11, 2004
1.1	<ul style="list-style-type: none"> ➤ Correct page 6 (3.0 Introduction) by removing 5V range. <p><i>“Flexible signal level requirement on the RS-232 like serial port side also allows the PL-2303X to connect directly to any 3.3V~1.8V range devices.”</i></p>	April 23, 2004
1.0A	<ul style="list-style-type: none"> ➤ Modify DC Characteristics of the Serial I/O Pins 	Dec 29, 2003
1.0	<ul style="list-style-type: none"> ➤ Change Preliminary Version to Formal Release 1.0 	Dec 15, 2003
0.9D	<ul style="list-style-type: none"> ➤ Added DC Characteristics of Serial I/O Pins and the Power-On Reset 	Sep 3, 2003
0.9C	<ul style="list-style-type: none"> ➤ Modify DC Characteristics 	Feb 13, 2003
0.9B	<ul style="list-style-type: none"> ➤ Added Outline Diagram Packaging 	Dec 23, 2002
0.9A	<ul style="list-style-type: none"> ➤ Preliminary Release – PL-2303X USB to Serial Bridge Controller Datasheet 	Dec 20, 2002

Table of Contents

1.0 FEATURES	5
2.0 FUNCTIONAL BLOCK DIAGRAM	6
3.0 INTRODUCTION	7
4.0 PIN ASSIGNMENT OUTLINE	8
4.1 SSOP28 Package	8
4.2 QFN Package.....	9
5.0 PIN ASSIGNMENT & DESCRIPTION	10
5.1 SSOP28 Package	10
5.2 QFN Package.....	11
6.0 USB STANDARD DESCRIPTORS	12
6.1 Device Descriptor	12
6.2 Configuration Descriptor	13
6.3 Interface Descriptor	13
6.4 Endpoint 1 Descriptor: Interrupt Input Endpoint	14
6.5 Endpoint 2 Descriptor: Bulk Data Output endpoint.....	14
6.6 Endpoint 3 Descriptor: Bulk Data Input endpoint	14
6.7 String Descriptors.....	15
7.0 USB STANDARD REQUESTS	16
8.0 DC & TEMPERATURE CHARACTERISTICS	17
8.1 Absolute Maximum Ratings	17
8.2 DC Characteristics	17
8.3 Clock Characteristics.....	19
8.4 Temperature Characteristics	19
8.5 Leakage Current and Capacitance.....	19
8.6 Power-On Reset.....	20

9.0 OUTLINE DIAGRAM.....	21
9.1 SSOP28 Package.....	21
9.2 QFN Package	22

1.0 Features

- Fully Compliant with USB Specification v1.1
- On Chip USB 1.1 transceiver, 5V→3.3V regulator, and 12 MHz crystal oscillator
- Supports RS-232 like Serial Interface
 - Full-duplex transmitter and receiver (TXD and RXD)
 - Six MODEM control pins (RTS, CTS, DTR, DSR, DCD, and RI)
 - 5, 6, 7 or 8 data bits
 - Odd, Even, Mark, Space, or None parity mode
 - One, one and a half, or two stop bits
 - Parity error, frame error, and serial break detection
 - Programmable baud rate from 75 bps to 6 Mbps
 - External RS-232 driver power down control
 - Independent power source for serial interface
- Extensive Flow Control Mechanism
 - Adjustable high/low watermark level
 - Automatic flow control with CTS/RTS
 - Automatic software flow control with XON/XOFF
 - Inbound data buffer overflow detection
- Configurable 512-byte bi-directional data buffer:
 - 256-byte outbound buffer and 256-byte inbound buffer; or
 - 128-byte outbound buffer and 384-byte inbound buffer.
- Support remote wake-up from MODEM input signals;
- Two general purpose I/O (GPIO) pins;
- Optional external EEPROM for startup device configurations;
- Small footprint 28-pin SSOP or 32-pin QFN IC package.

2.0 Functional Block Diagram

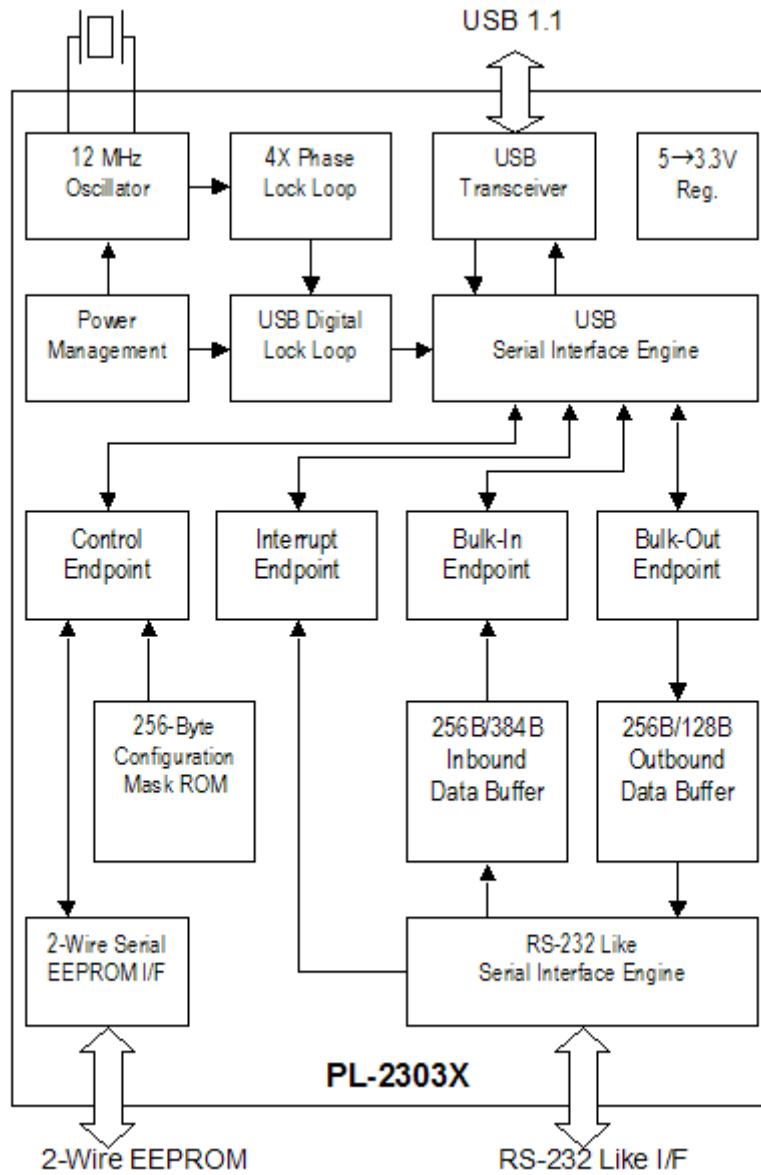

Figure 2-1 Block Diagram of PL-2303X

3.0 Introduction

The PL-2303X provides a convenient solution for connecting an RS-232 like full-duplex asynchronous serial device to any Universal Serial Bus (USB) capable host. The PL-2303X highly compatible drivers could simulate the traditional COM port on most operating systems allowing the existing applications based on COM port to easily migrate and be made USB ready.

By taking advantage of USB bulk transfer mode, large data buffers, and automatic flow control, the PL-2303X is capable of achieving higher throughput compared to traditional UART (Universal Asynchronous Receiver Transmitter) ports. When real RS-232 signaling is not required, baud rate higher than 115200 bps could be used for even higher performance. The flexible baud rate generator of PL-2303X could be programmed to generate any rate between 75 bps to 6,000,000 bps or 6Mbps.

The PL-2303X is exclusively designed for mobile and embedded solutions in mind, providing a small footprint that could easily fit in to any connectors and handheld devices. With very small power consumption in either operating or suspend mode, the PL-2303X is perfect for bus powered operation with plenty of power left for the attached devices. Flexible signal level requirement on the RS-232 like serial port side also allows the PL-2303X to connect directly to any 3.3V~1.8V range devices.

4.0 Pin Assignment Outline

4.1 SSOP28 Package

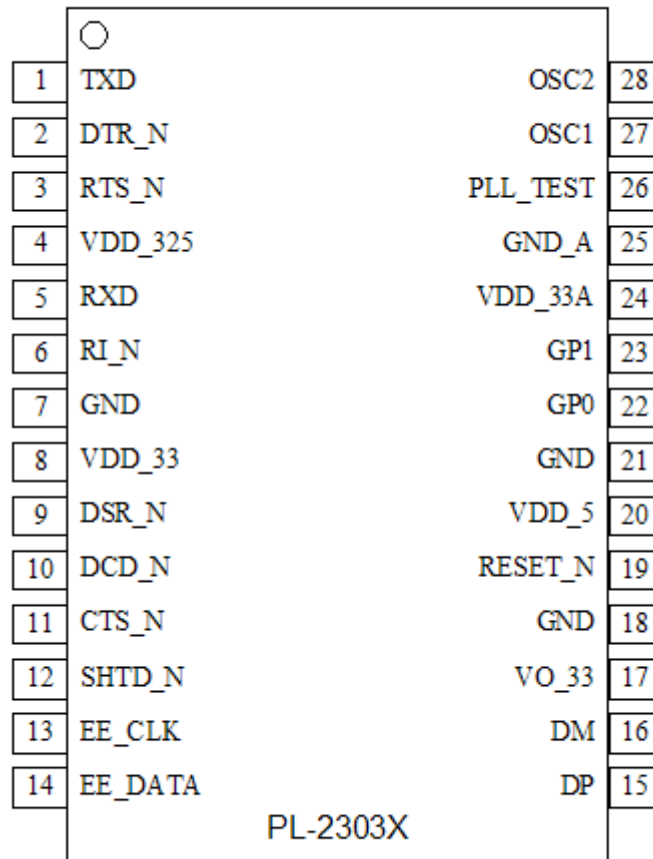

Figure 4-1 Pin Assignment Outline of PL-2303X (SSOP28)

4.2 QFN Package

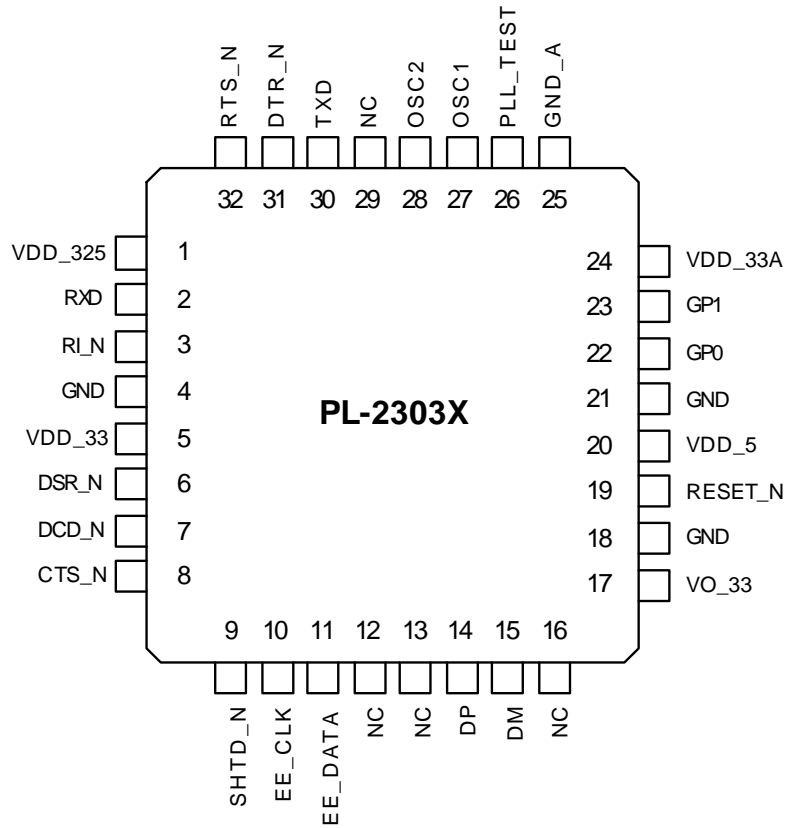

Figure 4-2 Pin Assignment Outline of PL-2303X (QFN)

5.0 PIN Assignment & Description

5.1 SSOP28 Package

Pin #	Name	Type	Description
1	TXD	O ⁽¹⁾	Serial port (Transmitted Data)
2	DTR_N	O ⁽¹⁾	Serial port (Data Terminal Ready)
3	RTS_N	O ⁽¹⁾	Serial port (Request To Send)
4	VDD_325	P	RS-232 VDD. The power pins for the serial port signals. When the serial port is 3.3V (5V tolerant), this should be 3.3V. When the serial port is 2.5V, this should be 2.5V.
5	RXD	I ⁽²⁾	Serial port (Received Data)
6	RI_N	I/O ⁽³⁾	Serial port (Ring Indicator)
7	GND	P	Ground
8	VDD_33	P	Primary Power (3.3V)
9	DSR_N	I/O ⁽³⁾	Serial port (Data Set Ready); or Auxiliary Serial port data signal when enabled.
10	DCD_N	I/O ⁽³⁾	Serial port (Data Carrier Detect)
11	CTS_N	I/O ⁽³⁾	Serial port (Clear To Send)
12	SHTD_N	O ⁽⁴⁾	RS232 Transceiver Shut Down Control
13	EE_CLK	I/O ⁽⁵⁾	2-Wire Serial EEPROM Clock
14	EE_DATA	I/O ⁽⁵⁾	2-Wire Serial EEPROM Data
15	DP	I/O	USB port D+ signal
16	DM	I/O	USB port D- signal
17	VO_33	P	Regulator Power Output, 3.3V
18	GND	P	Ground
19	RESET_N	I ⁽⁶⁾	External System Reset (Active Low)
20	VDD_5	P	USB port V _{BUS} , 5V Power.
21	GND	P	Ground
22	GP0	I/O ⁽⁵⁾	General Purpose I/O Pin 0
23	GP1	I/O ⁽⁵⁾	General Purpose I/O Pin 1
24	VDD_33A	P	Analog Power (3.3V) for PLL
25	GND_A	P	Analog Ground for PLL
26	PLL_TEST	I ⁽⁶⁾	PLL test mode control
27	OSC1	I	Crystal oscillator input
28	OSC2	I/O	Crystal oscillator output

Notes:

- (1) – CMOS Out, Output Pad. Level and Driving Capability decided by VDD_325.
- (2) – SCHMITT In, 5V Tolerant, Input Pad. Level and Driving Capability decided by VDD_325.
- (3) – SCHMITT In/CMOS Out, 5V Tolerant, Bi-directional Pad. Level and Driving Capability decided by VDD_325.
- (4) – CMOS Out, 3.3V, Output Pad, 4mA Output Driving Capability.
- (5) – SCHMITT In/CMOS Out, 5V Tolerant, Bi-directional Pad, 4mA Output Driving Capability.
- (6) – LVTTTL In, 3.3V, Input Pad.

5.2 QFN Package

Pin #	Name	Type	Description
1	VDD_325	P	RS-232 VDD. The power pins for the serial port signals. When the serial port is 3.3V (5V tolerant), this should be 3.3V. When the serial port is 2.5V, this should be 2.5V.
2	RXD	I ⁽²⁾	Serial port (Received Data)
3	RI_N	I/O ⁽³⁾	Serial port (Ring Indicator)
4	GND	P	Ground
5	VDD_33	P	Primary Power (3.3V)
6	DSR_N	I/O ⁽³⁾	Serial port (Data Set Ready); or Auxiliary Serial port data signal when enabled.
7	DCD_N	I/O ⁽³⁾	Serial port (Data Carrier Detect)
8	CTS_N	I/O ⁽³⁾	Serial port (Clear To Send)
9	SHTD_N	O ⁽⁴⁾	RS232 Transceiver Shut Down Control
10	EE_CLK	I/O ⁽⁵⁾	2-Wire Serial EEPROM Clock
11	EE_DATA	I/O ⁽⁵⁾	2-Wire Serial EEPROM Data
12	NC	-	Not Connected
13	NC	-	Not Connected
14	DP	I/O	USB port D+ signal
15	DM	I/O	USB port D- signal
16	NC	-	Not Connected
17	VO_33	P	Regulator Power Output, 3.3V
18	GND	P	Ground
19	RESET_N	I ⁽⁶⁾	External System Reset (Active Low)
20	VDD_5	P	USB port V _{BUS} , 5V Power.
21	GND	P	Ground
22	GP0	I/O ⁽⁵⁾	General Purpose I/O Pin 0
23	GP1	I/O ⁽⁵⁾	General Purpose I/O Pin 1
24	VDD_33A	P	Analog Power (3.3V) for PLL
25	GND_A	P	Analog Ground for PLL
26	PLL_TEST	I ⁽⁶⁾	PLL test mode control
27	OSC1	I	Crystal oscillator input
28	OSC2	I/O	Crystal oscillator output
29	NC	-	Not Connected
30	TXD	O ⁽¹⁾	Serial port (Transmitted Data)
31	DTR_N	O ⁽¹⁾	Serial port (Data Terminal Ready)
32	RTS_N	O ⁽¹⁾	Serial port (Request To Send)

Notes:

- (1)– CMOS Out, Output Pad. Level and Driving Capability decided by VDD_325.
- (2)– SCHMITT In, 5V Tolerant, Input Pad. Level and Driving Capability decided by VDD_325.
- (3)– SCHMITT In/CMOS Out, 5V Tolerant, Bi-directional Pad. Level and Driving Capability decided by VDD_325.
- (4)– CMOS Out, 3.3V, Output Pad, 4mA Output Driving Capability.

- (5) – SCHMITT In/CMOS Out, 5V Tolerant, Bi-directional Pad, 4mA Output Driving Capability.
- (6) – LVTTTL In, 3.3V, Input Pad.

6.0 USB Standard Descriptors

The PL-2303X supports one configuration with one interface and four endpoints. The descriptors are basically stored in an internal Mask ROM. However, some fields could be optionally modified by properly programmed external 2-wire serial EEPROM. The contents of all descriptors are shown in the following sections and the format of EEPROM would be given in later chapter.

6.1 Device Descriptor

Offset	Field	Size	Value	Description
0	<i>bLength</i>	Byte	12H	Size of this descriptor (in bytes)
1	<i>bDescriptorType</i>	Byte	01H	DEVICE descriptor type
2	<i>bcdUSB</i>	Word	0110H	USB Specification Release Number 1.1
4	<i>bDeviceClass</i>	Byte	00H	
5	<i>bDeviceSubClass</i>	Byte	00H	
6	<i>bDeviceProtocol</i>	Byte	00H	
7	<i>bMaxPacketSize0</i>	Byte	40H	Maximum packet size for endpoint zero is 64
8	<i>idVender</i>	Word	067BH	Vender ID ⁽¹⁾
10	<i>idProduct</i>	Word	2303H	Product ID ⁽¹⁾
12	<i>bcdDevice</i>	Word	0300H	Device Release Number ⁽¹⁾
14	<i>iManufacturer</i>	Byte	01H	Manufacturer string descriptor index
15	<i>iProduct</i>	Byte	02H	Product name string descriptor index
16	<i>iSerialNumber</i>	Byte	00H/03H	Serial number string descriptor index ⁽²⁾
17	<i>bNumConfigurations</i>	Byte	01H	One configuration.

Notes:

- (1) – The Vender ID, Product ID, and Device Release Number could be replaced by the contents of external EEPROM.
- (2) – The serial number string descriptor index could be defined by the contents of external EEPROM. If specified, the index will be 3 instead of 0.

6.2 Configuration Descriptor

Offset	Field	Size	Value	Description
0	<i>bLength</i>	Byte	09h	Size of this descriptor (in bytes)
1	<i>bDescriptorType</i>	Byte	02h	CONFIGURATION descriptor type
2	<i>wTotalLength</i>	Word	0027h	Total length of data returned for this configuration.
4	<i>bNumInterface</i>	Byte	01h	One interface for this device.
5	<i>bConfigurationValue</i>	Byte	01h	
6	<i>iConfiguration</i>	Byte	00h	
7	<i>bmAttributes</i>	Byte	A0h/80h	Characteristic attributes ⁽³⁾
8	<i>MaxPower</i>	Byte	32h/FAh	Maximum power consumption ⁽⁴⁾

Notes:

- (3) – The Remote Wakeup attribute (bit 5) depends on the settings of the Remote Wakeup Enable (bit 16 to 20 of Device Configuration Registers). If all remote wakeup sources are disabled, the *bmAttributes* will be 80h. Otherwise, A0h is returned to indicate that this device is Remote Wakeup capable.
- (4) – The value of maximum power consumption depends on the LD_MODE (bit 21 of Device Configuration Registers) parameter. If it is set to 1, the *MaxPower* byte will be FAh for it requires 500mA from the system. Otherwise, it is 32h that indicates 100mA required.

6.3 Interface Descriptor

Offset	Field	Size	Value	Description
0	<i>BLength</i>	Byte	09h	Size of this descriptor (in bytes)
1	<i>BDescriptorType</i>	Byte	04h	INTERFACE descriptor type
2	<i>BInterfaceNumber</i>	Byte	00h	One interface only
3	<i>BAlternateSetting</i>	Byte	00h	No alternate interface
4	<i>BNumEndpoints</i>	Byte	03h	Three endpoints (excluding control endpoint)
5	<i>BInterfaceClass</i>	Byte	FFh	Vendor Specific Class
6	<i>BInterfaceSubClass</i>	Byte	00h	
7	<i>BInterfaceProtocol</i>	Byte	00h	
8	<i>IInterface</i>	Byte	00h	

6.4 Endpoint 1 Descriptor: Interrupt Input Endpoint

Offset	Field	Size	Value	Description
0	<i>bLength</i>	Byte	07h	Size of this descriptor (in bytes)
1	<i>bDescriptorType</i>	Byte	05h	ENDPOINT descriptor type
2	<i>bEndpointAddress</i>	Byte	81h	Input endpoint
3	<i>bmAttributes</i>	Byte	03h	Transfer type is INTERRUPT
4	<i>wMaxPacketSize</i>	Word	000Ah	Ten Bytes
6	<i>bInterval</i>	Byte	01h	Polling on every 1 ms interval

6.5 Endpoint 2 Descriptor: Bulk Data Output endpoint

Offset	Field	Size	Value	Description
0	<i>bLength</i>	Byte	07h	Size of this descriptor (in bytes)
1	<i>bDescriptorType</i>	Byte	05h	ENDPOINT descriptor type
2	<i>bEndpointAddress</i>	Byte	02h	Output endpoint
3	<i>bmAttributes</i>	Byte	02h	Transfer type is BULK
4	<i>wMaxPacketSize</i>	Word	0040h	64 bytes
6	<i>bInterval</i>	Byte	00h	Ignored field

6.6 Endpoint 3 Descriptor: Bulk Data Input endpoint

Offset	Field	Size	Value	Description
0	<i>bLength</i>	Byte	07h	Size of this descriptor (in bytes)
1	<i>bDescriptorType</i>	Byte	05h	ENDPOINT descriptor type
2	<i>bEndpointAddress</i>	Byte	83h	Input endpoint
3	<i>bmAttributes</i>	Byte	02h	Transfer type is BULK
4	<i>wMaxPacketSize</i>	Word	0040h	64 bytes
6	<i>bInterval</i>	Byte	00h	Ignored field

6.7 String Descriptors

The PL-2303 supports four string descriptors:

- Language ID
- Manufacturer
- Product
- Serial Number

Except for Serial Number, the other three string descriptors are stored in the internal Mask ROM, i.e. their contents are fixed. Serial Number is a special case. If the External EEPROM were not present, or not properly programmed, then Serial Number would be hidden from the system. If the External EEPROM is presented and properly programmed, then Serial Number will be read from the EEPROM.

The following tables demonstrate the current defined value for each descriptor:

6.7.1 String Descriptor 0 – Language ID:

Offset	Field	Size	Value	Description
0	<i>bLength</i>	Byte	04h	Size of this descriptor (in bytes)
1	<i>bDescriptorType</i>	Byte	03h	STRING descriptor type
2	<i>bLANGID[0]</i>	Word	0409h	English (United States)

6.7.2 String Descriptor 1 - Manufacturer:

Offset	Field	Size	Value	Description
0	<i>BLength</i>	Byte	32h	Size of this descriptor (in bytes)
1	<i>bDescriptorType</i>	Byte	03h	STRING descriptor type
2	<i>bSTRING</i>	—	⇒	“Prolific Technology Inc.” in UNICODE

6.7.3 String Descriptor 2 - Product:

Offset	Field	Size	Value	Description
0	<i>Blength</i>	Byte	2Ch	Size of this descriptor (in bytes)
1	<i>bDescriptorType</i>	Byte	03h	STRING descriptor type
2	<i>bSTRING</i>	—	⇒	“USB-Serial Controller” in UNICODE

6.7.4 String Descriptor 3 – Serial Number:

Offset	Field	Size	Value	Description
0	<i>bLength</i>	Byte	12h	Size of this descriptor (in bytes)
1	<i>bDescriptorType</i>	Byte	03h	STRING descriptor type
2	<i>bSTRING</i>	—	⇒	"X ₇ X ₆ X ₅ X ₄ X ₃ X ₂ X ₁ X ₀ " in UNICODE

Note:

The size of Serial Number is fixed in PL-2303X design. It must be exactly 8 UNICODE characters (or 16 bytes).

Note that in USB Specification, this serial number must be unique for each device.

7.0 USB Standard Requests

The PL-2303X supports the following USB standard requests. For non-supported requests, or requests with invalid parameters, the PL-2303X will respond with STALL packet.

- Clear Feature
- Get Configuration
- Get Descriptor
- Get Status
 - Device Status
 - Interface Status
 - Endpoint 0, 1, 2, and 3 Status
- Set Address
- Set Configuration
- Set Feature

8.0 DC & Temperature Characteristics

8.1 Absolute Maximum Ratings

Items	Ratings
Power Supply Voltage	-0.3 to 5.5 V
Input Voltage of 3.3V I/O	-0.3 to $V_{DD}+0.3$ V
Input Voltage of 3.3V I/O with 5V Tolerance I/O	-0.3 to $V_{DD5}+0.3V$
Output Voltage of 3.3V I/O	-0.3 to $V_{DD} +0.3$ V
Storage Temperature	-40 to 150 °C

8.2 DC Characteristics

8.2.1 3.3V I/O Pins

Parameter	Symbol	Min	Typ	Max	Unit
Output Driving Capability	I_{DD}	--	4	--	mA
Output Voltage of Regulator	V_{DD}	3.0	3.3	3.6	V
Input Voltage (CMOS)					
Low	V_{IL}	--	--	$0.3 * V_{DD}$	V
High	V_{IH}	$0.7 * V_{DD}$	--	--	V
Input Voltage (LVTTL)					
Low	V_{IL}	--	--	0.8	V
High	V_{IH}	2.0	--	--	V
Schmitt Trigger Threshold Voltage					
Negative going	V_{t-}	0.9	1.2	--	V
Positive going	V_{t+}	--	2.1	2.5	V
Output Voltage, 3.3V ^{*1}					
Low	V_{OL}	--	--	0.4	V
High	V_{OH}	2.4	--	--	V
Operating Voltage Range	V_{CC}	4.4	5	5.25	V
Suspend Current	I_{SUS}	-	400	450	uA

Note:

*1. The Output Driving Capability is 4mA.

8.2.2 Serial I/O Pins

VDD_325 @ 3.3V

Parameter	Symbol	Min	Typ	Max	Unit
Power Supply for Serial I/O Pins	V_{DD_325}	3.0	3.3	3.6	V
Input Voltage					
Low	V_{IL}	--	--	0.8	V
High	V_{IH}	2.0	--	--	V
Schmitt Trigger Threshold Voltage					
Negative going	V_{t-}	0.8	1.1	--	V
Positive going	V_{t+}	--	1.6	2.0	V
Output Voltage ^{*1}					
Low	V_{OL}	--	--	0.4	V
High	V_{OH}	2.4	--	--	V

Note:

*1. The Output Driving Capability is 4mA.

VDD_325 @ 2.5V

Parameter	Symbol	Min	Typ	Max	Unit
Power Supply for Serial I/O Pins	V_{DD_325}	2.25	2.5	2.75	V
Input Voltage					
Low	V_{IL}	--	--	$0.25 * V_{DD_325}$	V
High	V_{IH}	$0.7 * V_{DD_325}$	--	--	V
Schmitt Trigger Threshold Voltage					
Negative going	V_{t-}	$0.25 * V_{DD_325}$	0.84	--	V
Positive going	V_{t+}	--	1.31	$0.7 * V_{DD_325}$	V
Output Voltage ^{*1}					
Low	V_{OL}	--	--	0.4	V
High	V_{OH}	1.85	--	--	V

Note:

*1. The Output Driving Capability is 2.6mA.

VDD_325 @ 1.8V

Parameter	Symbol	Min	Typ	Max	Unit
Power Supply for Serial I/O Pins	V _{DD_325}	1.65	1.8	1.95	V
Input Voltage					
Low	V _{IL}	--	--	0.25* V _{DD_325}	V
High	V _{IH}	0.7* V _{DD_325}	--	--	V
Schmitt Trigger Threshold Voltage					
Negative going	V _{t-}	0.25* V _{DD_325}	0.6	--	V
Positive going	V _{t+}	--	1.04	0.7* V _{DD_325}	V
Output Voltage ^{*1}					
Low	V _{OL}	--	--	0.4	V
High	V _{OH}	1.25	--	--	V

Note:

*1. The Output Driving Capability is 1.4mA.

8.3 Clock Characteristics

Parameter	Min	Typ	Max	Units
Frequency of Operation	11.976	12.000	12.024	MHz
Clock Period	83.1	83.3	83.5	ns
Duty Cycle	45	50	55	%

8.4 Temperature Characteristics

Parameter	Symbol	Min	Typ	Max	Unit
Operating Temperature	--	-40	--	85	°C
Junction Operation Temperature	T _J	-40	25	125	°C

8.5 Leakage Current and Capacitance

Parameter	Symbol	Min	Typ	Max	Unit
Input Leakage Current ^{*1}	I _L	-10	±1	10	uA
Tri-state Leakage Current	I _{oz}	-10	±1	10	uA
Input Capacitance	C _{IN}	--	2.8	--	pF
Output Capacitance	C _{OUT}	2.7	--	4.9	pF
Bi-directional Buffer Capacitance	C _{BID}	2.7	--	4.9	pF

Note:

*1. No pull-up or pull-down resistor.

8.6 Power-On Reset

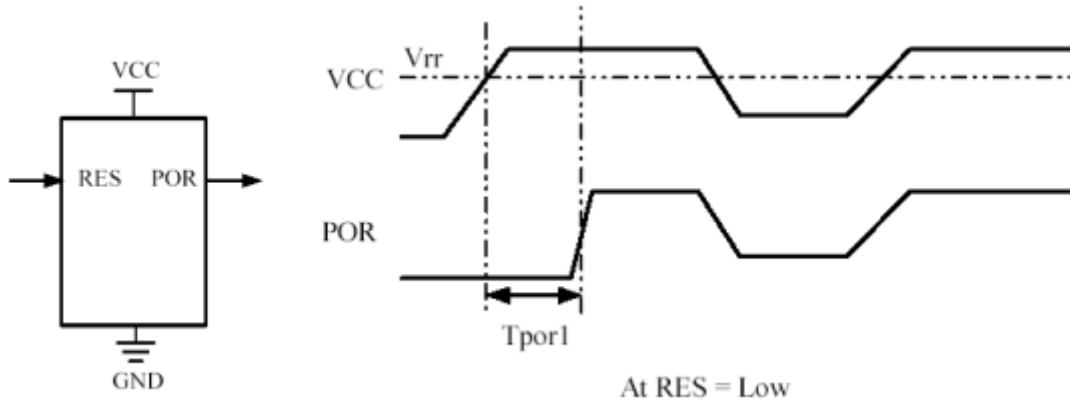

Description and Condition	Symbol	Min	Typ	Max	Unit
Power supply voltage	VCC	2.8	3.3	4.0	V
VCC rise relax voltage	V_{rr}	1.8	2.3	2.8	V
Power output low duration $VCC _{rise} @ V_{rr} \text{ to } POR _{rise} @ 1/2 * VCC$ (VCC slew rate = 1V/1us)	T_{por1}	2.6	3.7	4.8	uS

9.0 Outline Diagram

9.1 SSOP28 Package

Package Dimension

Symbol	Millimeter			Inch		
	Min	Nom	Max	Min	Nom	Max
b	0.22		0.38	0.009		0.015
E	7.40	7.80	8.20	0.291	0.307	0.323
E1	5.00	5.30	5.60	0.197	0.209	0.220
L	0.55	0.75	0.95	0.021	0.030	0.037
R1	0.09			0.004		
D	9.9	10.2	10.5	0.390	0.402	0.413
A			2.0			0.079
e		0.65			0.0256	
L1		1.25			0.050	
A1	0.05			0.020		
A2	1.65	1.75	1.85	0.065	0.069	0.073

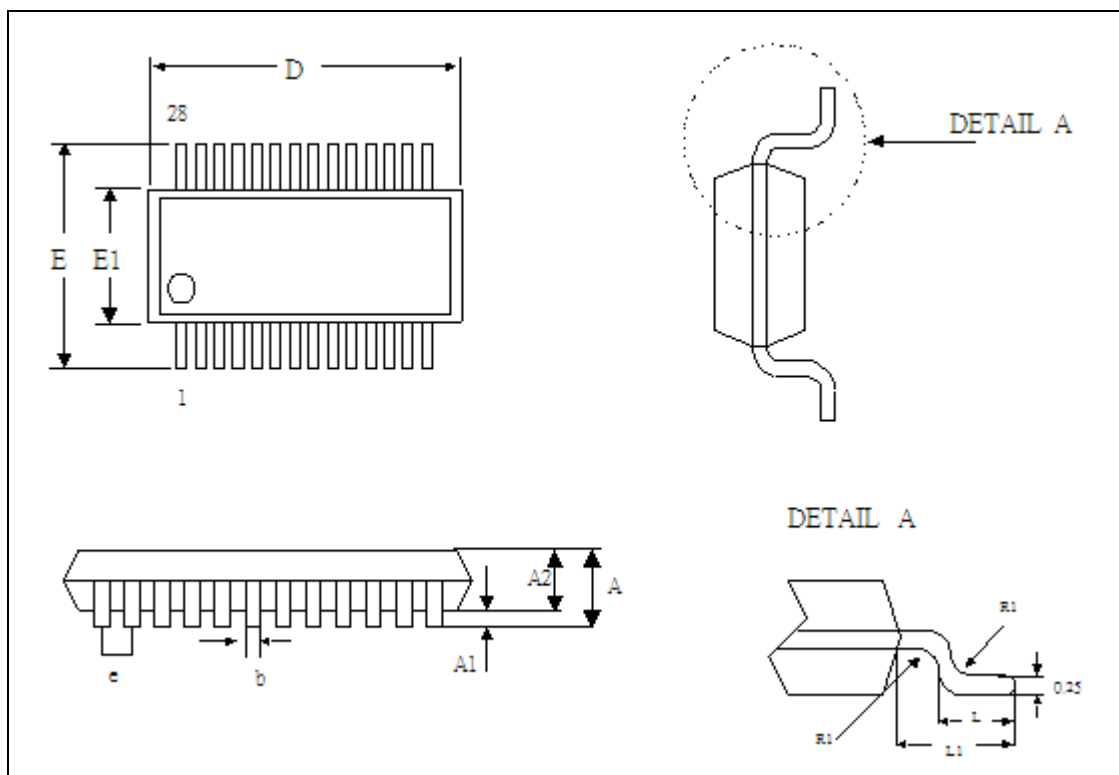

Figure 9-1 Outline Diagram of PL-2303X SSOP28

9.2 QFN Package

Package Dimension

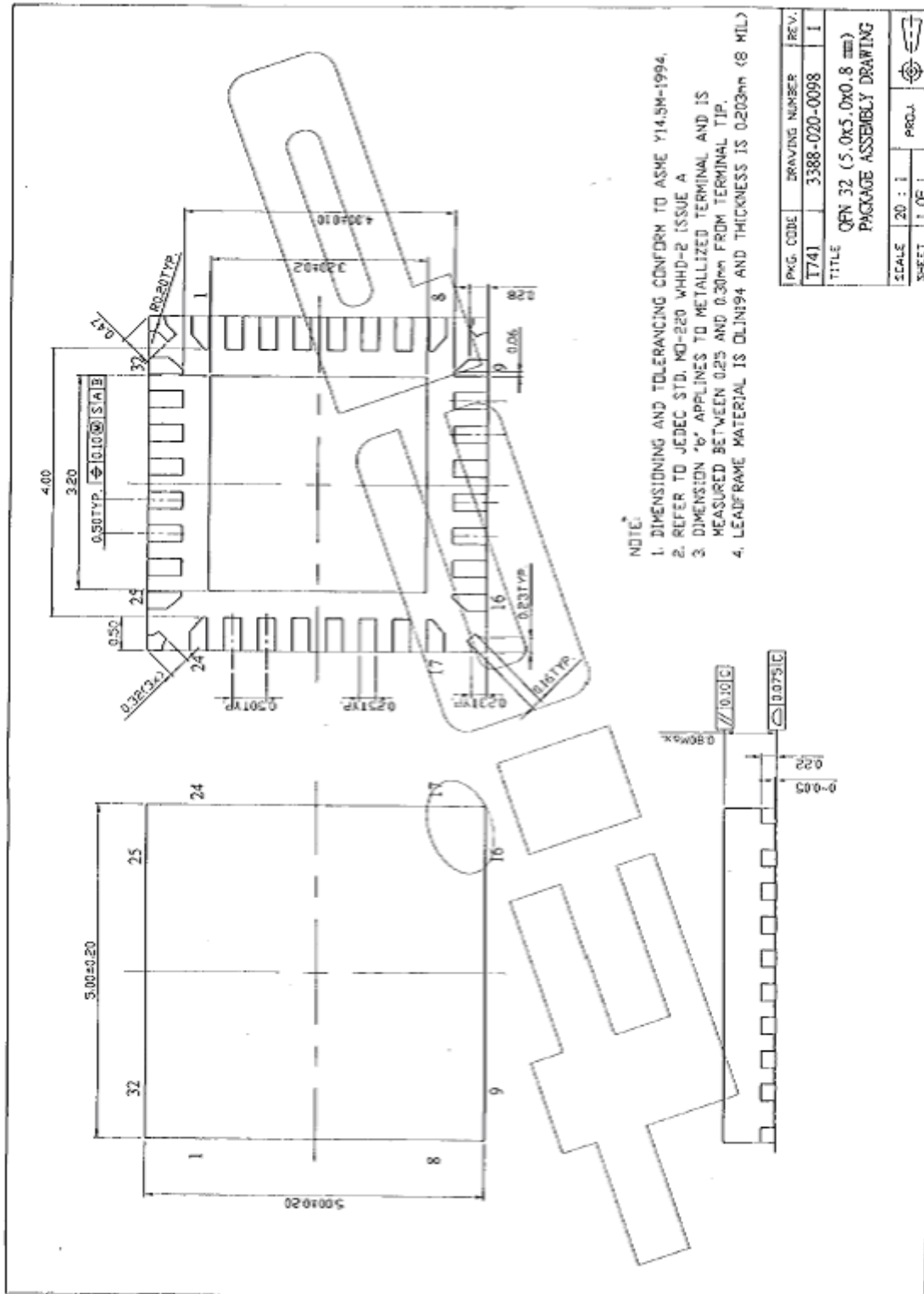

Figure 9-2 Outline Diagram of PL-2303X QFN 32-Pin