HM5118165B Series

1048576-word × 16-bit Dynamic Random Access Memory

HITACHI

ADE-203-000 (Z)
Preliminary
Rev. 1.0
Dec. 1, 1995

Description

The Hitachi HM5118165B is a CMOS dynamic RAM organized as 1,048,576-word × 16-bit. It employs the most advanced CMOS technology for high performance and low power. The HM5118165B offers Extended Data Out (EDO) Page Mode as a high speed access mode.

Features

- Single 5 V ($\pm 10\%$)
- High speed
 - Access time : 60 ns/70 ns/80 ns (max)
- Low power dissipation
 - Active mode : 935 mW/825 mW/715mW (max)
 - Standby mode : 11 mW (max)
: 0.83 mW (max) (L-version)
- EDO page mode capability
- Long refresh period
 - 1024 refresh cycles : 16 ms
: 128 ms (L-version)
- 4 variations of refresh
 - $\overline{\text{RAS}}$ -only refresh
 - $\overline{\text{CAS}}$ -before- $\overline{\text{RAS}}$ refresh
 - Hidden refresh
 - Self refresh (L-version)
- $2\overline{\text{CAS}}$ -byte control
- Battery backup operation (L-version)

Note: The specifications of this device are subject to change without notice. Please contact your nearest Hitachi's Sales Dept. regarding specifications.

This specification is fully compatible with the 16-Mbit DRAM specifications from TEXAS INSTRUMENTS.

HM5118165B Series

Ordering Information

Type No.	Access time	Package
HM5118165BJ-6	60 ns	400-mil 42-pin plastic SOJ (CP-42D)
HM5118165BJ-7	70 ns	
HM5118165BJ-8	80 ns	
HM5118165BLJ-6	60 ns	400-mil 50-pin plastic TSOP II (TTP-50/44DC)
HM5118165BLJ-7	70 ns	
HM5118165BLJ-8	80 ns	
HM5118165BTT-6	60 ns	400-mil 50-pin plastic TSOP II (TTP-50/44DC)
HM5118165BTT-7	70 ns	
HM5118165BTT-8	80 ns	
HM5118165BLTT-6	60 ns	400-mil 50-pin plastic TSOP II (TTP-50/44DC)
HM5118165BLTT-7	70 ns	
HM5118165BLTT-8	80 ns	

Pin Arrangement

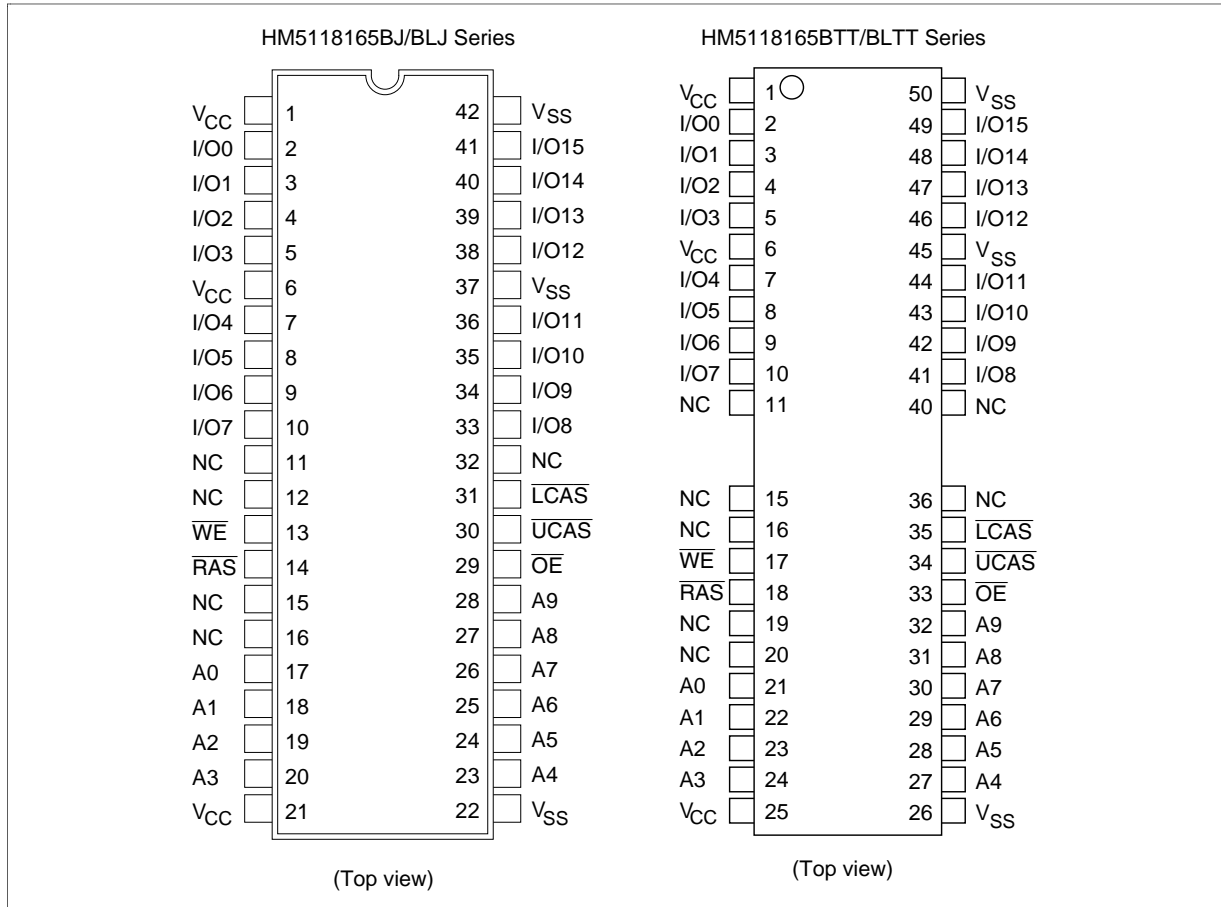

Pin Description

Pin name	Function
A0 to A9	Address input
A0 to A9	Refresh address input
I/O0 to I/O15	Data input/Data output
RAS	Row address strobe
UCAS, LCAS	Column address strobe
WE	Read/Write enable
OE	Output enable
V _{CC}	Power supply (+5 V)
V _{SS}	Ground
NC	No connection

HM5118165B Series

Block Diagram

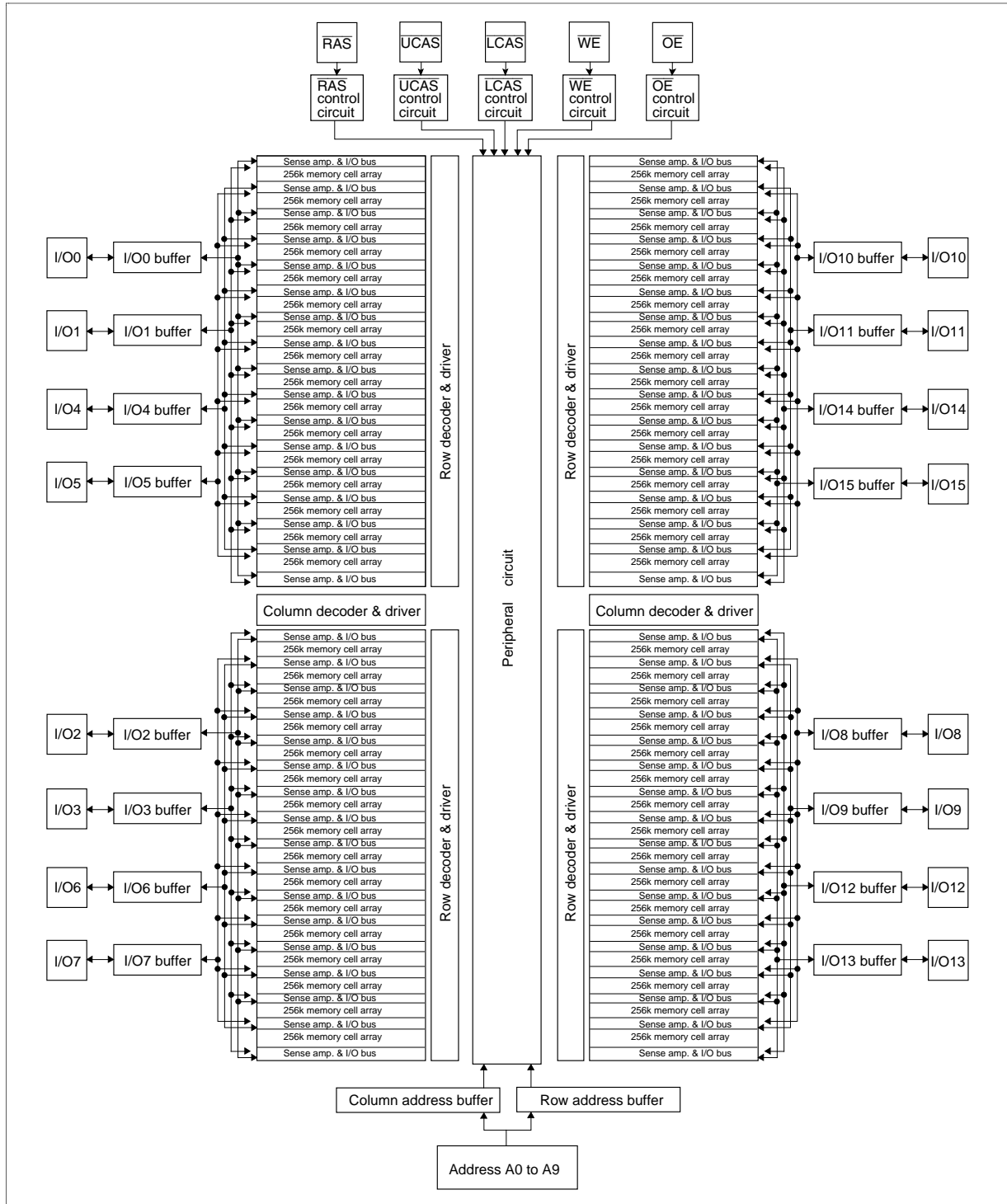

Truth Table

$\overline{\text{RAS}}$	$\overline{\text{LCAS}}$	$\overline{\text{UCAS}}$	$\overline{\text{WE}}$	$\overline{\text{OE}}$	Output		Operation
H	D	D	D	D	Open		Standby
L	L	H	H	L	Valid	Lower byte	Read cycle
L	H	L	H	L	Valid	Upper byte	
L	L	L	H	L	Valid	Word	
L	L	H	L ²	D	Open	Lower byte	Early write cycle
L	H	L	L ²	D	Open	Upper byte	
L	L	L	L ²	D	Open	Word	
L	L	H	L ²	H	Undefined	Lower byte	Delayed write cycle
L	H	L	L ²	H	Undefined	Upper byte	
L	L	L	L ²	H	Undefined	Word	
L	L	H	H to L	L to H	Valid	Lower byte	Read-modify-write cycle
L	H	L	H to L	L to H	Valid	Upper byte	
L	L	L	H to L	L to H	Valid	Word	
L	H	H	D	D	Open	Word	$\overline{\text{RAS}}$ -only refresh cycle
H to L	H	L	D	D	Open	Word	$\overline{\text{CAS}}$ -before- $\overline{\text{RAS}}$ refresh cycle or
H to L	L	H	D	D	Open	Word	Self refresh cycle (L-version)
H to L	L	L	D	D	Open	Word	
L	L	L	H	H	Open		Read cycle (Output disabled)

Notes: 1. H: High (inactive) L: Low (active) D: H or L

2. $t_{\text{wcs}} \geq 0 \text{ ns}$ Early write cycle

$t_{\text{wcs}} < 0 \text{ ns}$ Delayed write cycle

3. Mode is determined by the OR function of the $\overline{\text{UCAS}}$ and $\overline{\text{LCAS}}$. (Mode is set by the earliest of $\overline{\text{UCAS}}$ and $\overline{\text{LCAS}}$ active edge and reset by the latest of $\overline{\text{UCAS}}$ and $\overline{\text{LCAS}}$ inactive edge.) However write OPERATION and output HIZ control are done independently by each $\overline{\text{UCAS}}$, $\overline{\text{LCAS}}$.

ex. if $\overline{\text{RAS}} = \text{H to L}$, $\overline{\text{UCAS}} = \text{H}$, $\overline{\text{LCAS}} = \text{L}$, then $\overline{\text{CAS}}$ -before- $\overline{\text{RAS}}$ refresh cycle is selected.

HM5118165B Series

Absolute Maximum Ratings

Parameter	Symbol	Value	Unit
Voltage on any pin relative to V_{SS}	V_T	-1.0 to +7.0	V
Supply voltage relative to V_{SS}	V_{CC}	-1.0 to +7.0	V
Short circuit output current	I_{out}	50	mA
Power dissipation	P_T	1.0	W
Operating temperature	T_{opr}	0 to +70	°C
Storage temperature	T_{stg}	-55 to +125	°C

Recommended DC Operating Conditions ($T_a = 0$ to +70°C)

Parameter	Symbol	Min	Typ	Max	Unit	Notes
Supply voltage	V_{CC}	4.5	5.0	5.5	V	1, 2
Input high voltage	V_{IH}	2.4	—	6.5	V	1
Input low voltage	V_{IL}	-1.0	—	0.8	V	1

Notes: 1. All voltage referred to V_{SS}

2. The supply voltage with all V_{CC} pins must be on the same level. The supply voltage with all V_{SS} pins must be on the same level.

DC Characteristics ($T_a = 0$ to +70°C, $V_{CC} = 5\text{ V} \pm 10\%$, $V_{SS} = 0\text{ V}$)

		HM5118165B							
		-6		-7		-8			
Parameter	Symbol	Min	Max	Min	Max	Min	Max	Unit	Test conditions
Operating current ^{1, 2}	I_{CC1}	—	170	—	150	—	130	mA	$t_{RC} = \text{min}$
Standby current	I_{CC2}	—	2	—	2	—	2	mA	TTL interface RAS, UCAS, LCAS = V_{IH} Dout = High-Z
		—	1	—	1	—	1	mA	CMOS interface RAS, UCAS, LCAS $\geq V_{CC} - 0.2\text{ V}$ Dout = High-Z
Standby current (L-version)	I_{CC2}	—	150	—	150	—	150	μA	CMOS interface RAS, UCAS, LCAS $\geq V_{CC} - 0.2\text{ V}$ Dout = High-Z

HM5118165B Series

DC Characteristics (Ta = 0 to +70°C, V_{CC} = 5 V ± 10%, V_{SS} = 0 V) (cont)

Parameter	Symbol	HM5118165B						Unit	Test conditions
		-6		-7		-8			
		Min	Max	Min	Max	Min	Max		
RAS-only refresh current ²	I _{CC3}	—	170	—	150	—	130	mA	t _{RC} = min
Standby current ¹	I _{CC5}	—	5	—	5	—	5	mA	RAS = V _{IH} , UCAS, LCAS = V _{IL} Dout = enable
CAS-before-RAS refresh current	I _{CC6}	—	170	—	150	—	130	mA	t _{RC} = min
EDO page mode current ^{1,3}	I _{CC7}	—	185	—	165	—	150	mA	t _{HPC} = min
Battery backup current ⁴ (Standby with CBR refresh) (L-version)	I _{CC10}	—	500	—	500	—	500	μA	CMOS interface Dout = High-Z CBR refresh: t _{RC} = 125 μs t _{RAS} ≤ 0.3 μs
Self refresh mode current (L-version)	I _{CC11}	—	300	—	300	—	300	μA	CMOS interface RAS, UCAS, LCAS ≤ 0.2 V Dout = High-Z
Input leakage current	I _{LI}	-10	10	-10	10	-10	10	μA	0 V ≤ Vin ≤ 7 V
Output leakage current	I _{LO}	-10	10	-10	10	-10	10	μA	0 V ≤ Vout ≤ 7 V Dout = disable
Output high voltage	V _{OH}	2.4	V _{CC}	2.4	V _{CC}	2.4	V _{CC}	V	High Iout = -2 mA
Output low voltage	V _{OL}	0	0.4	0	0.4	0	0.4	V	Low Iout = 2 mA

- Notes: 1. I_{CC} depends on output load condition when the device is selected. I_{CC} max is specified at the output open condition.
 2. Address can be changed once or less while RAS = V_{IL}.
 3. Address can be changed once or less while UCAS and LCAS = V_{IH}.
 4. V_{IH} ≥ V_{CC} - 0.2 V, 0 V ≤ V_{IL} ≤ 0.2 V.

Capacitance (Ta = 25°C, V_{CC} = 5 V ± 10%)

Parameter	Symbol	Typ	Max	Unit	Notes
Input capacitance (Address)	C _{I1}	—	5	pF	1
Input capacitance (Clocks)	C _{I2}	—	7	pF	1
Output capacitance (Data-in, Data-out)	C _{I/O}	—	7	pF	1, 2

- Notes: 1. Capacitance measured with Boonton Meter or effective capacitance measuring method.
 2. RAS, UCAS and LCAS = V_{IH} to disable Dout.

HM5118165B Series

AC Characteristics (Ta = 0 to +70°C, V_{CC} = 5 V ± 10%, V_{SS} = 0 V)^{*1, *2, *18}

Test Conditions

- Input rise and fall time: 2 ns
- Input levels: 0 V, 3.0 V
- Input timing reference levels: 0.8 V, 2.4 V
- Output timing reference levels: 0.8 V, 2.0 V
- Output load: 1 TTL gate + C_L (100 pF) (Including scope and jig)

Read, Write, Read-Modify-Write and Refresh Cycles (Common parameters)

		HM5118165B							
		-6		-7		-8			
Parameter	Symbol	Min	Max	Min	Max	Min	Max	Unit	Notes
Random read or write cycle time	t _{RC}	104	—	124	—	144	—	ns	
$\overline{\text{RAS}}$ precharge time	t _{RP}	40	—	50	—	60	—	ns	
$\overline{\text{CAS}}$ precharge time	t _{CP}	10	—	13	—	15	—	ns	
$\overline{\text{RAS}}$ pulse width	t _{RAS}	60	10000	70	10000	80	10000	ns	
$\overline{\text{CAS}}$ pulse width	t _{CAS}	10	10000	13	10000	15	10000	ns	
Row address setup time	t _{ASR}	0	—	0	—	0	—	ns	
Row address hold time	t _{RAH}	10	—	10	—	10	—	ns	
Column address setup time	t _{ASC}	0	—	0	—	0	—	ns	21
Column address hold time	t _{CAH}	10	—	13	—	15	—	ns	21
$\overline{\text{RAS}}$ to $\overline{\text{CAS}}$ delay time	t _{RCD}	20	45	20	52	20	60	ns	3
$\overline{\text{RAS}}$ to column address delay time	t _{RAD}	15	30	15	35	15	40	ns	4
$\overline{\text{RAS}}$ hold time	t _{RSH}	15	—	18	—	20	—	ns	
$\overline{\text{CAS}}$ hold time	t _{CSH}	48	—	58	—	68	—	ns	
$\overline{\text{CAS}}$ to $\overline{\text{RAS}}$ precharge time	t _{CRP}	5	—	5	—	5	—	ns	
$\overline{\text{OE}}$ to Din delay time	t _{OED}	15	—	18	—	20	—	ns	5
$\overline{\text{OE}}$ delay time from Din	t _{DZO}	0	—	0	—	0	—	ns	6
$\overline{\text{CAS}}$ delay time from Din	t _{DZC}	0	—	0	—	0	—	ns	6
Transition time (rise and fall)	t _T	2	50	2	50	2	50	ns	7

HM5118165B Series

Read Cycle

Parameter	Symbol	HM5118165B						Unit	Notes
		-6		-7		-8			
		Min	Max	Min	Max	Min	Max		
Access time from $\overline{\text{RAS}}$	t_{RAC}	—	60	—	70	—	80	ns	8, 9
Access time from $\overline{\text{CAS}}$	t_{CAC}	—	15	—	18	—	20	ns	9, 10, 17
Access time from address	t_{AA}	—	30	—	35	—	40	ns	9, 11, 17
Access time from $\overline{\text{OE}}$	t_{OEA}	—	15	—	18	—	20	ns	9
Read command setup time	t_{RCS}	0	—	0	—	0	—	ns	21
Read command hold time to $\overline{\text{CAS}}$	t_{RCH}	0	—	0	—	0	—	ns	12, 22
Read command hold time from $\overline{\text{RAS}}$	t_{RCHR}	60	—	70	—	80	—	ns	
Read command hold time to $\overline{\text{RAS}}$	t_{RRH}	5	—	5	—	5	—	ns	12
Column address to $\overline{\text{RAS}}$ lead time	t_{RAL}	30	—	35	—	40	—	ns	
Column address to $\overline{\text{CAS}}$ lead time	t_{CAL}	18	—	23	—	28	—	ns	
$\overline{\text{CAS}}$ to output in low-Z	t_{CLZ}	0	—	0	—	0	—	ns	
Output data hold time	t_{OH}	3	—	3	—	3	—	ns	27
Output data hold time from $\overline{\text{OE}}$	t_{OHO}	3	—	3	—	3	—	ns	
Output buffer turn-off time	t_{OFF}	—	15	—	15	—	15	ns	13, 27
Output buffer turn-off to $\overline{\text{OE}}$	t_{OEZ}	—	15	—	15	—	15	ns	13
$\overline{\text{CAS}}$ to Din delay time	t_{CDD}	15	—	18	—	20	—	ns	5
Output data hold time from $\overline{\text{RAS}}$	t_{OHR}	3	—	3	—	3	—	ns	27
Output buffer turn-off to $\overline{\text{RAS}}$	t_{OFR}	—	15	—	15	—	15	ns	27
Output buffer turn-off to $\overline{\text{WE}}$	t_{WEZ}	—	15	—	15	—	15	ns	
$\overline{\text{WE}}$ to Din delay time	t_{WED}	15	—	18	—	20	—	ns	
$\overline{\text{RAS}}$ to Din delay time	t_{RDD}	15	—	18	—	20	—	ns	

HM5118165B Series

Write Cycle

		HM5118165B							
		-6		-7		-8			
Parameter	Symbol	Min	Max	Min	Max	Min	Max	Unit	Notes
Write command setup time	t_{WCS}	0	—	0	—	0	—	ns	14, 21
Write command hold time	t_{WCH}	10	—	13	—	15	—	ns	21
Write command pulse width	t_{WP}	10	—	10	—	10	—	ns	
Write command to \overline{RAS} lead time	t_{RWL}	10	—	13	—	15	—	ns	
Write command to \overline{CAS} lead time	t_{CWL}	10	—	13	—	15	—	ns	
Data-in setup time	t_{DS}	0	—	0	—	0	—	ns	15
Data-in hold time	t_{DH}	10	—	13	—	15	—	ns	15

Read-Modify-Write Cycle

		HM5118165B							
		-6		-7		-8			
Parameter	Symbol	Min	Max	Min	Max	Min	Max	Unit	Notes
Read-modify-write cycle time	t_{RWC}	136	—	161	—	185	—	ns	
\overline{RAS} to \overline{WE} delay time	t_{RWD}	79	—	92	—	104	—	ns	14
\overline{CAS} to \overline{WE} delay time	t_{CWD}	34	—	40	—	44	—	ns	14
Column address to \overline{WE} delay time	t_{AWD}	49	—	57	—	64	—	ns	14
\overline{OE} hold time from \overline{WE}	t_{OEH}	15	—	18	—	20	—	ns	

Refresh Cycle

		HM5118165B							
		-6		-7		-8			
Parameter	Symbol	Min	Max	Min	Max	Min	Max	Unit	Notes
\overline{CAS} setup time (CBR refresh cycle)	t_{CSR}	5	—	5	—	5	—	ns	21
\overline{CAS} hold time (CBR refresh cycle)	t_{CHR}	10	—	10	—	10	—	ns	
\overline{RAS} precharge to \overline{CAS} hold time	t_{RPC}	0	—	0	—	0	—	ns	21

HM5118165B Series

EDO Page Mode Cycle

		HM5118165B							
		-6		-7		-8			
Parameter	Symbol	Min	Max	Min	Max	Min	Max	Unit	Notes
EDO page mode cycle time	t_{HPC}	25	—	30	—	35	—	ns	25
EDO page mode \overline{RAS} pulse width	t_{RASP}	—	100000	—	100000	—	100000	ns	16
Access time from \overline{CAS} precharge	t_{CPA}	—	35	—	40	—	45	ns	9, 17
\overline{RAS} hold time from \overline{CAS} precharge	t_{CPRH}	35	—	40	—	45	—	ns	
Output data hold time from \overline{CAS} low	t_{DOH}	3	—	3	—	3	—	ns	9, 17
\overline{CAS} hold time referred \overline{OE}	t_{COL}	10	—	13	—	15	—	ns	
\overline{CAS} to \overline{OE} setup time	t_{COP}	5	—	5	—	5	—	ns	
Read command hold time from \overline{CAS} precharge	t_{RCHC}	35	—	40	—	45	—	ns	

EDO Page Mode Read-Modify-Write Cycle

		HM5118165B							
		-6		-7		-8			
Parameter	Symbol	Min	Max	Min	Max	Min	Max	Unit	Notes
EDO page mode read-modify-write cycle time	t_{HPRWC}	68	—	79	—	88	—	ns	
\overline{WE} delay time from \overline{CAS} precharge	t_{CPW}	54	—	62	—	69	—	ns	14

Refresh



Parameter	Symbol	Max	Unit	Note
Refresh period	t_{REF}	16	ms	1024 cycles
Refresh period (L-version)	t_{REF}	128	ms	1024 cycles

HM5118165B Series

Self Refresh Mode (L-version)

		HM5118165BL							
		-6		-7		-8			
Parameter	Symbol	Min	Max	Min	Max	Min	Max	Unit	Notes
$\overline{\text{RAS}}$ pulse width (self refresh)	t_{RASS}	100	—	100	—	100	—	μs	
$\overline{\text{RAS}}$ precharge time (self refresh)	t_{RPS}	110	—	130	—	150	—	ns	
$\overline{\text{CAS}}$ hold time (self refresh)	t_{CHS}	-50	—	-50	—	-50	—	ns	

- Notes:
- AC measurements assume $t_T = 2 \text{ ns}$.
 - An initial pause of 200 μs is required after power up followed by a minimum of eight initialization cycles (any combination of cycles containing $\overline{\text{RAS}}$ -only refresh or $\overline{\text{CAS}}$ -before- $\overline{\text{RAS}}$ refresh).
 - Operation with the t_{RCD} (max) limit insures that t_{RAC} (max) can be met, t_{RCD} (max) is specified as a reference point only; if $t_{\text{RCD}} \geq t_{\text{RAD}} (\text{max}) + t_{\text{AA}} - t_{\text{CAC}} (\text{max})$, then access time is controlled exclusively by t_{CAC} .
 - Operation with the t_{RAD} (max) limit insures that t_{RAC} (max) can be met, t_{RAD} (max) is specified as a reference point only; if t_{RAD} is greater than the specified t_{RAD} (max) limit, then access time is controlled exclusively by t_{AA} .
 - Either t_{OED} or t_{CDD} must be satisfied.
 - Either t_{DZO} or t_{DZC} must be satisfied.
 - V_{IH} (min) and V_{IL} (max) are reference levels for measuring timing of input signals. Also, transition times are measured between V_{IH} (min) and V_{IL} (max).
 - Assumes that $t_{\text{RCD}} \leq t_{\text{RCD}} (\text{max})$ and $t_{\text{RAD}} \leq t_{\text{RAD}} (\text{max})$. If t_{RCD} or t_{RAD} is greater than the maximum recommended value shown in this table, t_{RAC} exceeds the value shown.
 - Measured with a load circuit equivalent to 1 TTL loads and 100 pF.
 - Assumes that $t_{\text{RCD}} \geq t_{\text{RCD}} (\text{max})$ and $t_{\text{RCD}} + t_{\text{CAC}} (\text{max}) \geq t_{\text{RAD}} + t_{\text{AA}} (\text{max})$.
 - Assumes that $t_{\text{RAD}} \geq t_{\text{RAD}} (\text{max})$ and $t_{\text{RCD}} + t_{\text{CAC}} (\text{max}) \leq t_{\text{RAD}} + t_{\text{AA}} (\text{max})$.
 - Either t_{RCH} or t_{RRH} must be satisfied for a read cycles.
 - $t_{\text{OFF}} (\text{max})$ and $t_{\text{OEZ}} (\text{max})$ define the time at which the outputs achieve the open circuit condition and are not referred to output voltage levels.
 - t_{WCS} , t_{RWD} , t_{CWD} , t_{AWD} and t_{CPW} are not restrictive operating parameters. They are included in the data sheet as electrical characteristics only; if $t_{\text{WCS}} \geq t_{\text{WCS}} (\text{min})$, the cycle is an early write cycle and the data out pin will remain open circuit (high impedance) throughout the entire cycle; if $t_{\text{RWD}} \geq t_{\text{RWD}} (\text{min})$, $t_{\text{CWD}} \geq t_{\text{CWD}} (\text{min})$, and $t_{\text{AWD}} \geq t_{\text{AWD}} (\text{min})$, or $t_{\text{CWD}} \geq t_{\text{CWD}} (\text{min})$, $t_{\text{AWD}} \geq t_{\text{AWD}} (\text{min})$ and $t_{\text{CPW}} \geq t_{\text{CPW}} (\text{min})$, the cycle is a read-modify-write and the data output will contain data read from the selected cell; if neither of the above sets of conditions is satisfied, the condition of the data out (at access time) is indeterminate.
 - These parameters are referred to $\overline{\text{UCAS}}$ and $\overline{\text{LCAS}}$ leading edge in early write cycles and to $\overline{\text{WE}}$ leading edge in delayed write or read-modify-write cycles.
 - t_{RASP} defines $\overline{\text{RAS}}$ pulse width in EDO page mode cycles.
 - Access time is determined by the longest among t_{AA} , t_{CAC} and t_{CPA} .
 - In delayed write or read-modify-write cycles, $\overline{\text{OE}}$ must disable output buffer prior to applying data to the device. After $\overline{\text{RAS}}$ is reset, if $t_{\text{OEH}} \geq t_{\text{CWL}}$, the I/O pin will remain open circuit (high impedance); if $t_{\text{OEH}} < t_{\text{CWL}}$, invalid data will be out at each I/O.
 - When both $\overline{\text{UCAS}}$ and $\overline{\text{LCAS}}$ go low at the same time, all 16-bit data are written into the device. $\overline{\text{UCAS}}$ and $\overline{\text{LCAS}}$ cannot be staggered within the same write/read cycles.

20. All the V_{CC} and V_{SS} pins shall be supplied with the same voltages.
21. t_{ASC} , t_{CAH} , t_{RCS} , t_{WCS} , t_{WCH} , t_{CSR} and t_{RPC} are determined by the earlier falling edge of \overline{UCAS} or \overline{LCAS} .
22. t_{CRP} , t_{CHR} , t_{RCH} , t_{CPA} and t_{CPW} are determined by the later rising edge of \overline{UCAS} or \overline{LCAS} .
23. t_{CWL} , t_{DH} , t_{DS} and t_{CHS} should be satisfied by both \overline{UCAS} and \overline{LCAS} .
24. t_{CP} is determined by the time that both \overline{UCAS} and \overline{LCAS} are high.
25. t_{HPC} (min) can be achieved during a series of EDO page mode write cycles or EDO page mode read cycles. If both write and read operation are mixed in a EDO page mode RAS cycle (EDO page mode mix cycle (1), (2)), minimum value of \overline{CAS} cycle ($t_{CAS} + t_{CP} + 2 t_T$) becomes greater than the specified t_{HPC} (min) value. The value of \overline{CAS} cycle time of mixed EDO page mode is shown in EDO page mode mix cycle (1) and (2).
26. When output buffers are enabled once, sustain the low impedance state until valid data is obtained. When output buffer is turned on and off within a very short time, generally it causes large V_{CC}/V_{SS} line noise, which causes to degrade V_{IH} min/ V_{IL} max level.
27. Data output turns off and becomes high impedance from later rising edge of \overline{RAS} and \overline{CAS} . Hold time and turn off time are specified by the timing specifications of later rising edge of \overline{RAS} and \overline{CAS} between t_{OHR} and t_{OH} , and between t_{OFR} and t_{OFF} .
28. Please do not use t_{RASS} timing, $10 \mu s \leq t_{RASS} \leq 100 \mu s$. During this period, the device is in transition state from normal operation mode to self refresh mode. If $t_{RASS} \geq 100 \mu s$, then \overline{RAS} precharge time should use t_{RPS} instead of t_{RP} .
29. If you use distributed CBR refresh mode with $15.6 \mu s$ interval in normal read/write cycle, CBR refresh should be executed within $15.6 \mu s$ immediately after exiting from and before entering into self refresh mode.
30. If you use \overline{RAS} only refresh or CBR burst refresh mode in normal read/write cycle, 1024 cycles of distributed CBR refresh with $15.6 \mu s$ interval should be executed within 16 ms immediately after exiting from and before entering into the self refresh mode.
31. Repetitive self refresh mode without refreshing all memory is not allowed. Once you exit from self refresh mode, all memory cells need to be refreshed before re-entering the self refresh mode again.
32.  H or L (H: $V_{IH}(\min) \leq V_{IN} \leq V_{IH}(\max)$, L: $V_{IL}(\min) \leq V_{IN} \leq V_{IL}(\max)$)
 Invalid Dout

HM5118165B Series

Notes concerning $\overline{2CAS}$ control

Please do not separate the $\overline{UCAS}/\overline{LCAS}$ operation timing intentionally. However skew between $\overline{UCAS}/\overline{LCAS}$ are allowed under the following conditions.

1. Each of the $\overline{UCAS}/\overline{LCAS}$ should satisfy the timing specifications individually.
2. Different operation mode for upper/lower byte is not allowed; such as following.

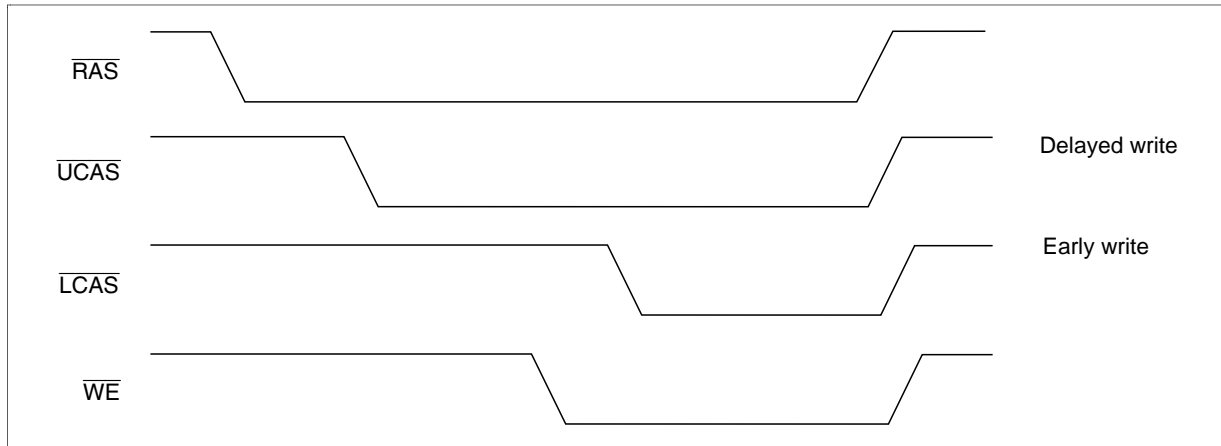

3. Closely separated upper/lower byte control is not allowed. However when the condition ($t_{CP} \leq t_{UL}$) is satisfied, EDO page mode can be performed.

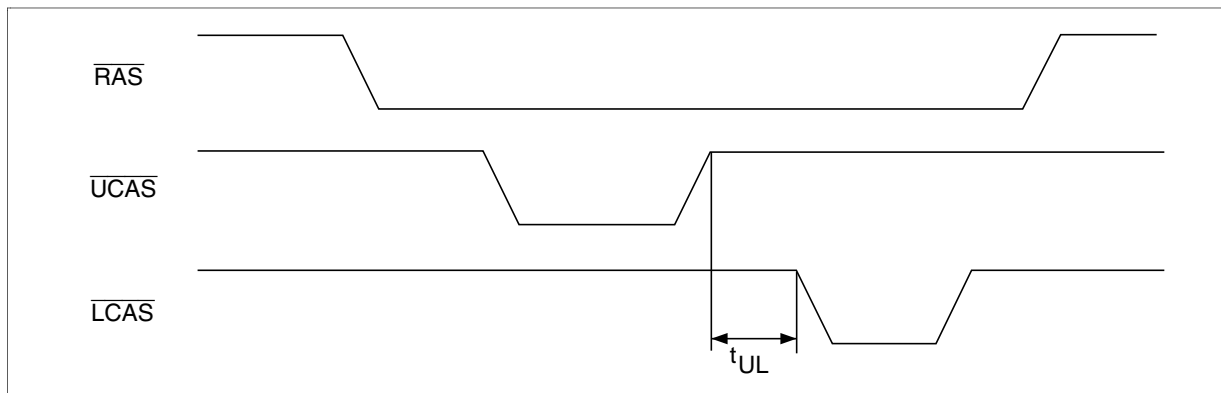

4. Byte control operation by remaining \overline{UCAS} or \overline{LCAS} high is guaranteed.

Timing Waveforms^{*32}

Read Cycle

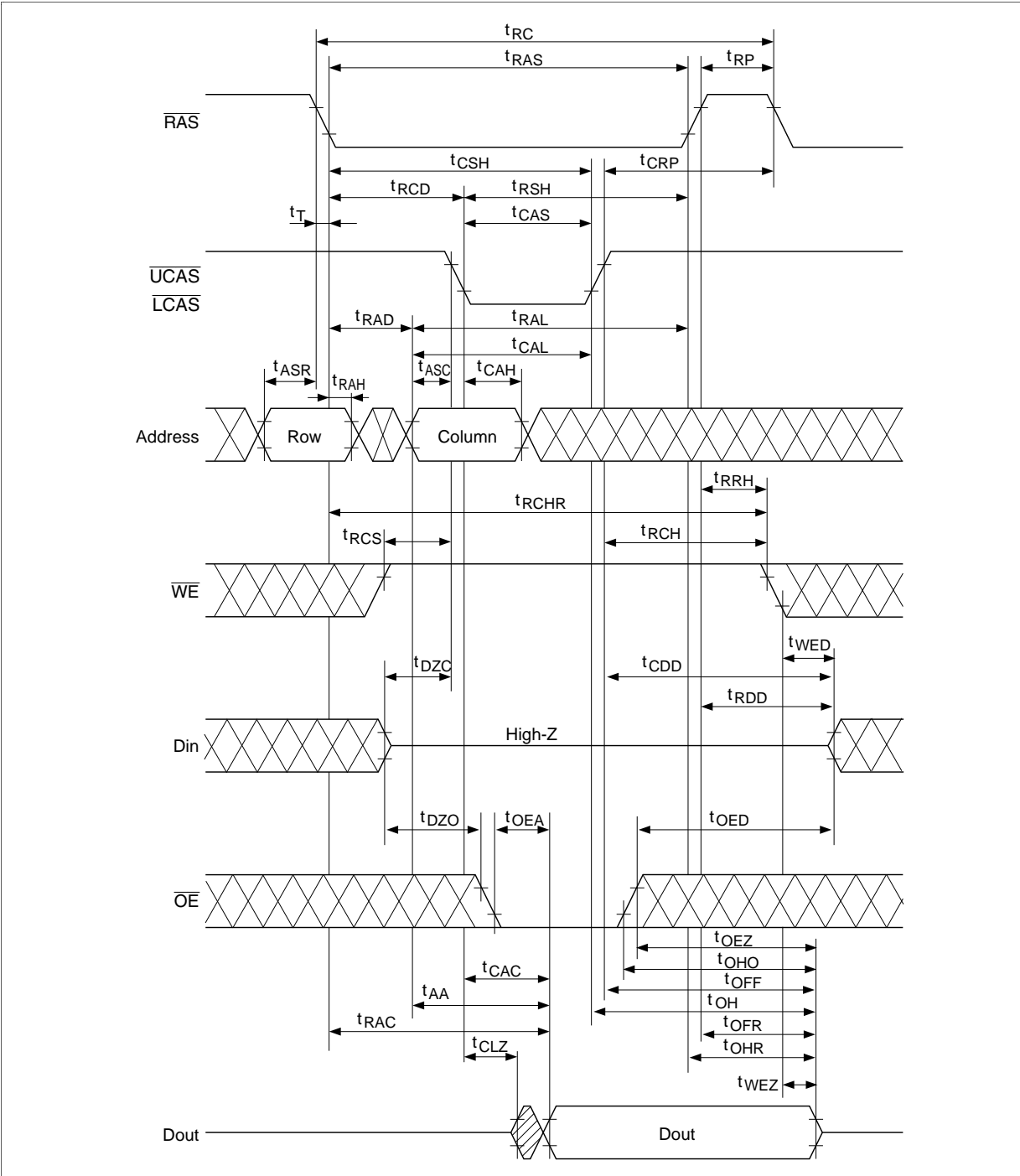

HM5118165B Series

Early Write Cycle

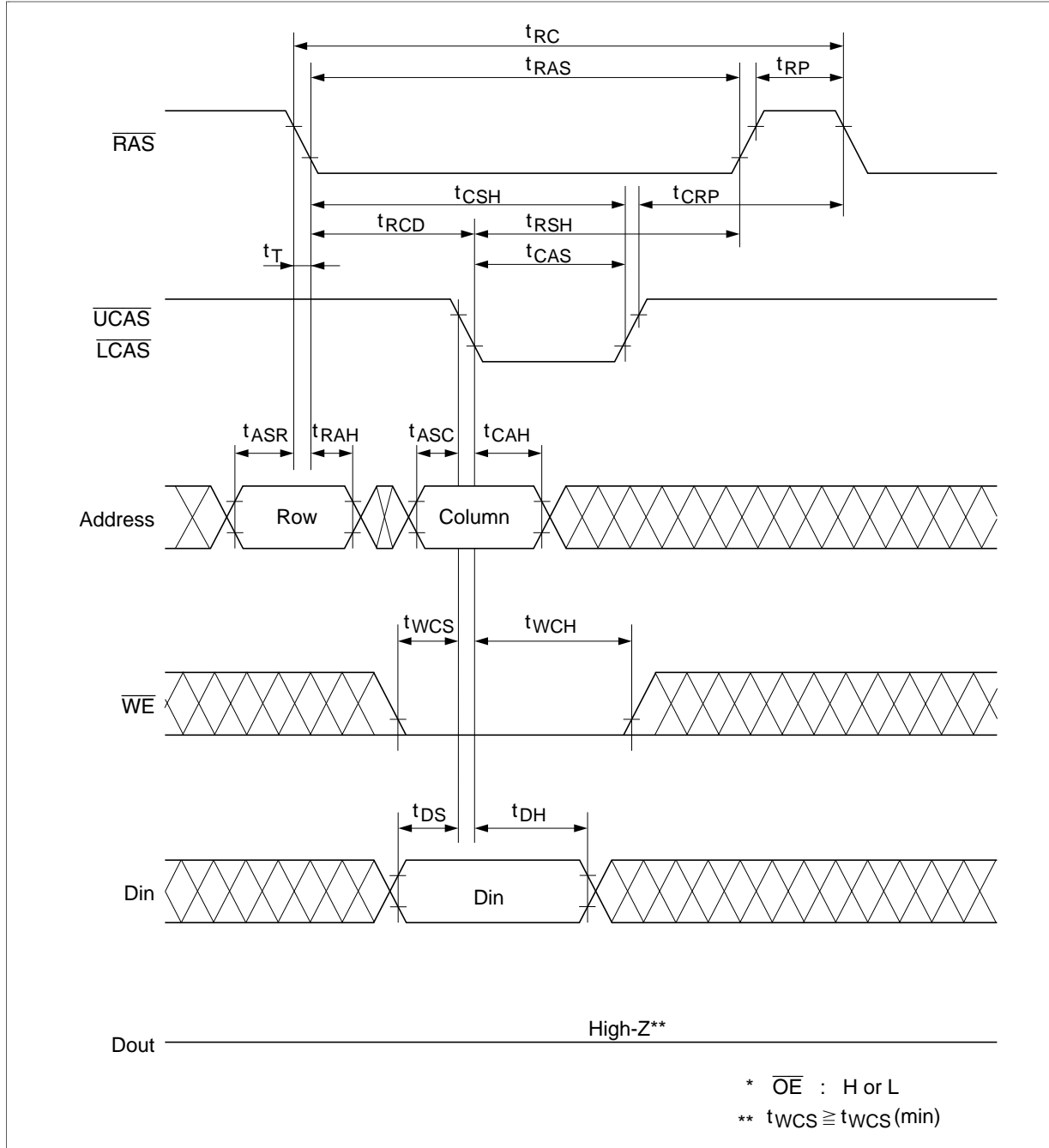

Delayed Write Cycle ^{*18}

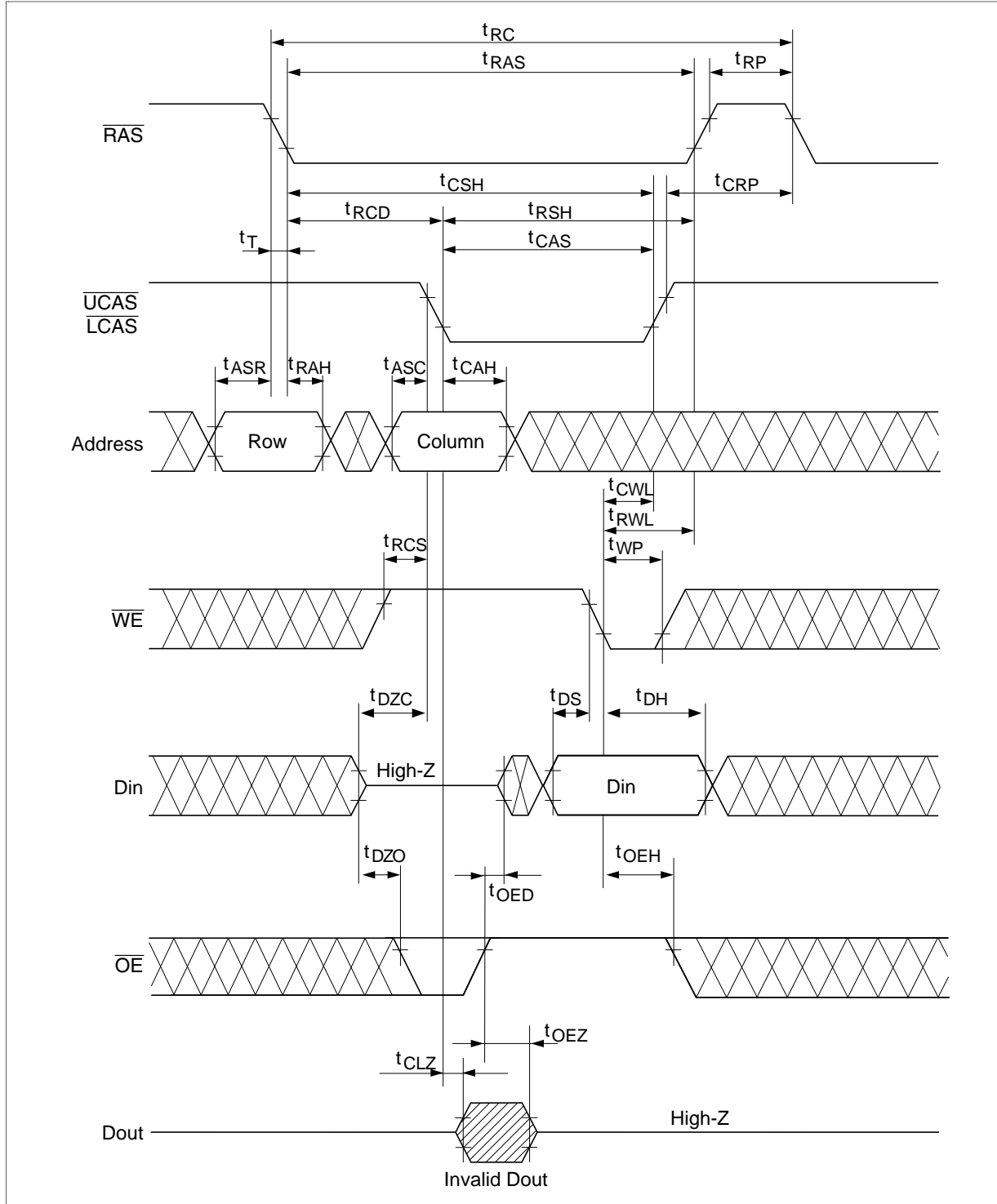

HM5118165B Series

Read-Modify-Write Cycle^{*18}

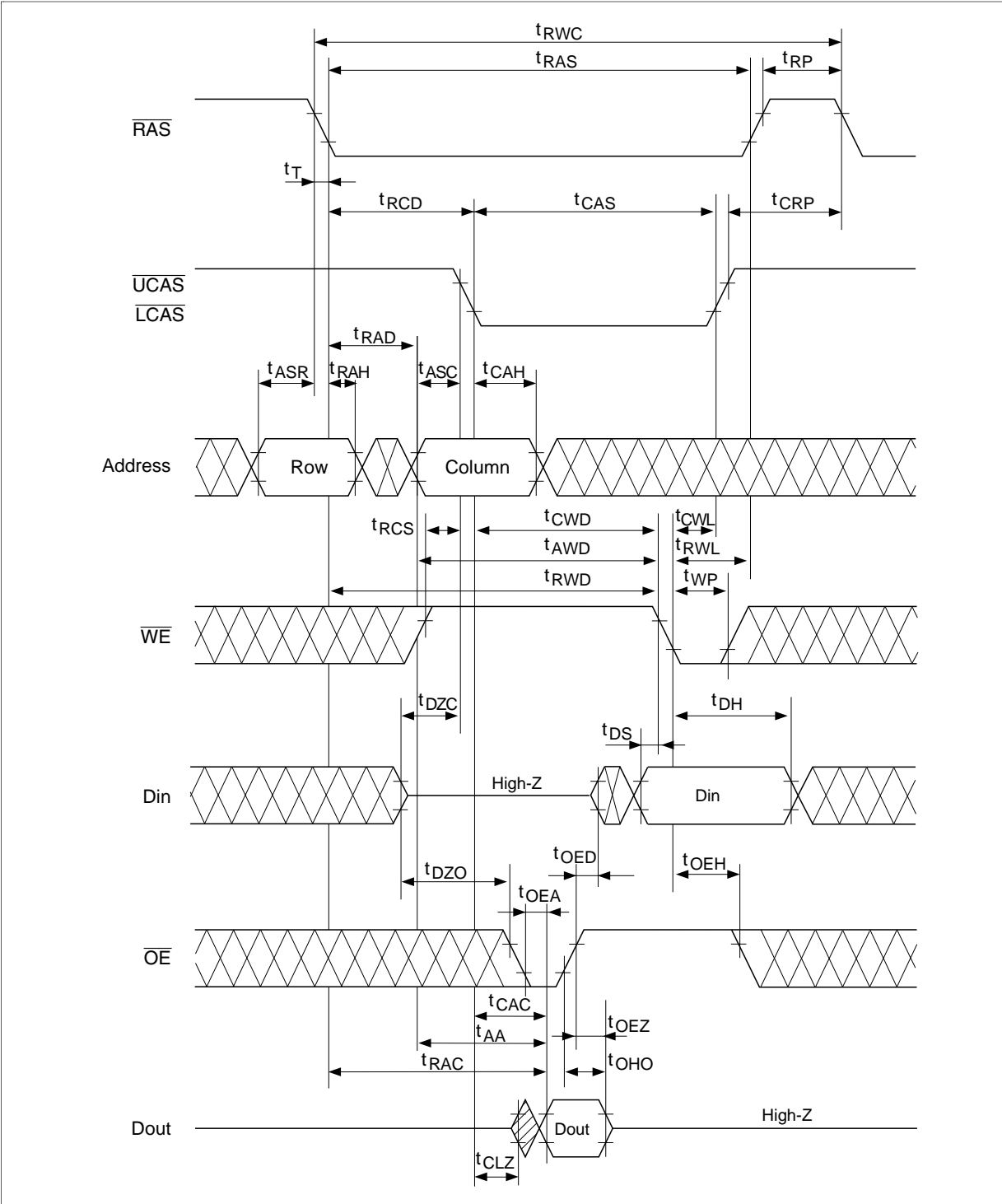

$\overline{\text{RAS}}$ -Only Refresh Cycle

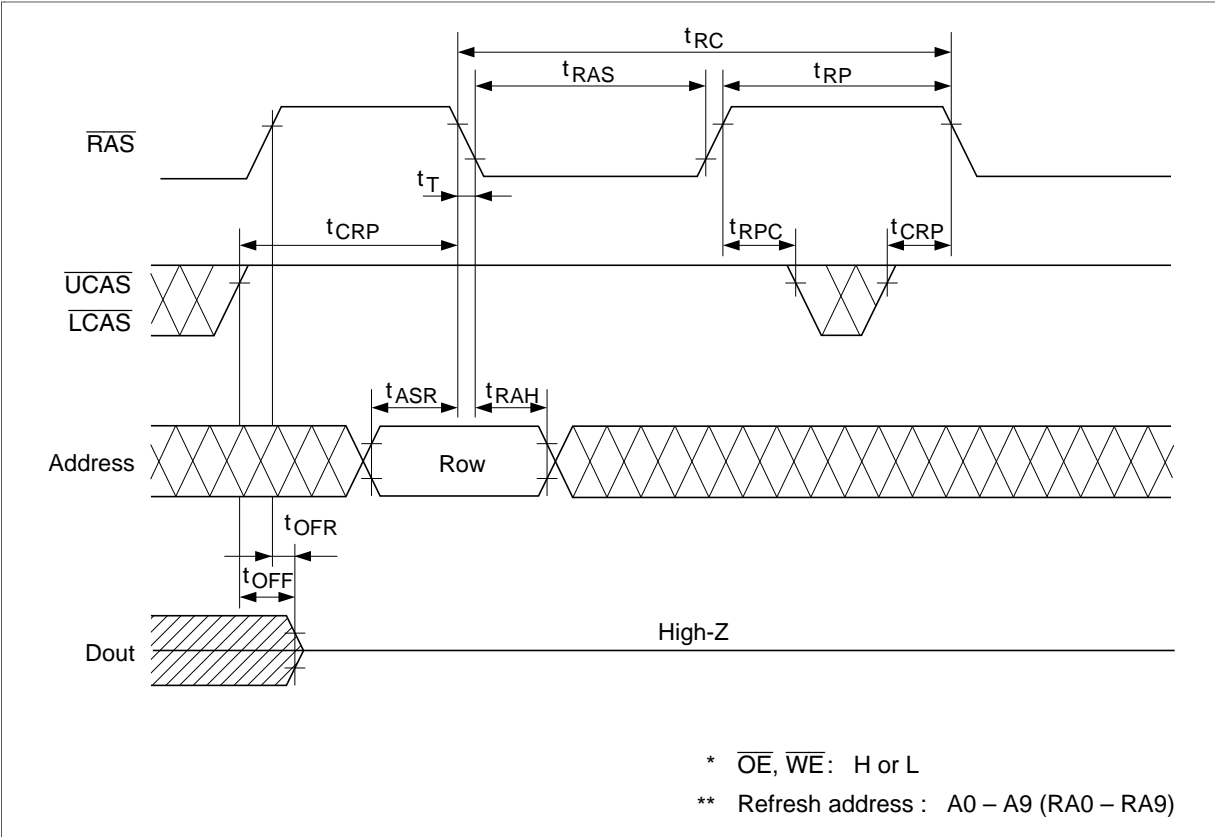

HM5118165B Series

$\overline{\text{CAS}}$ -Before- $\overline{\text{RAS}}$ Refresh Cycle

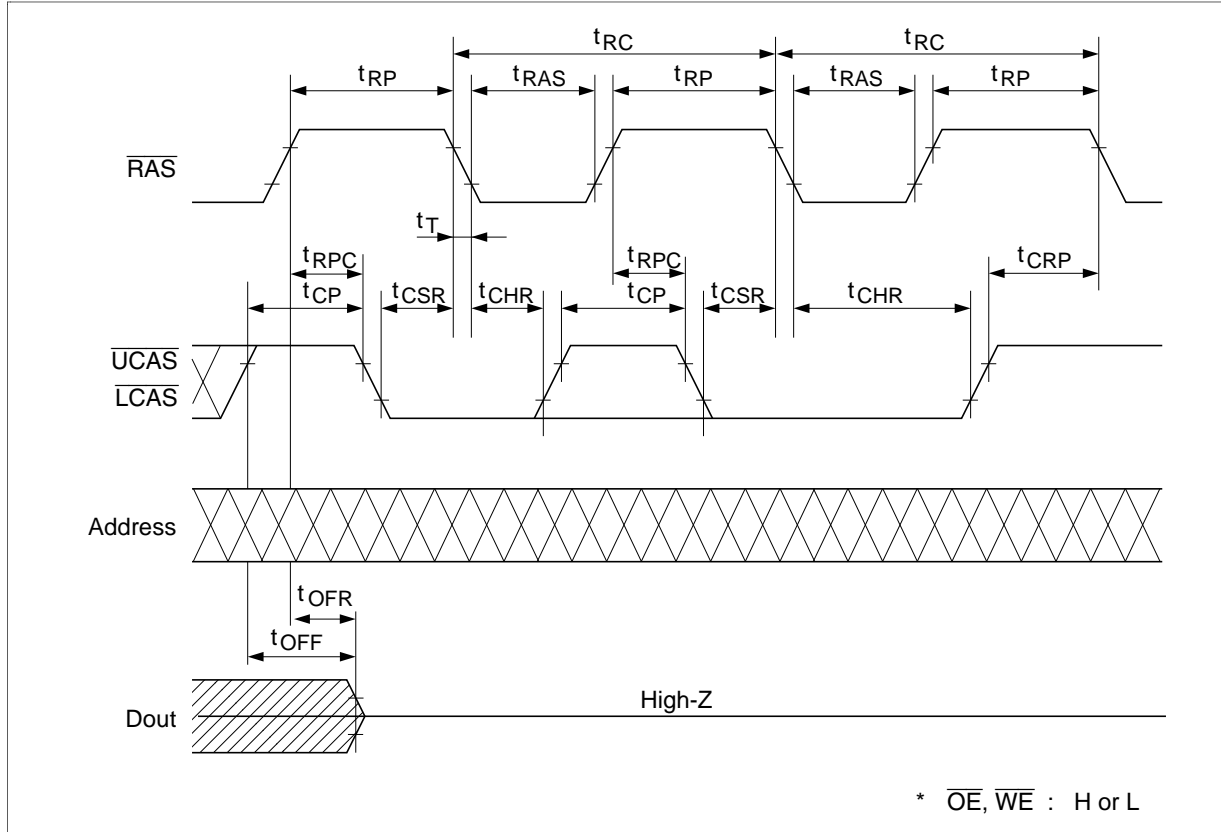

Hidden Refresh Cycle

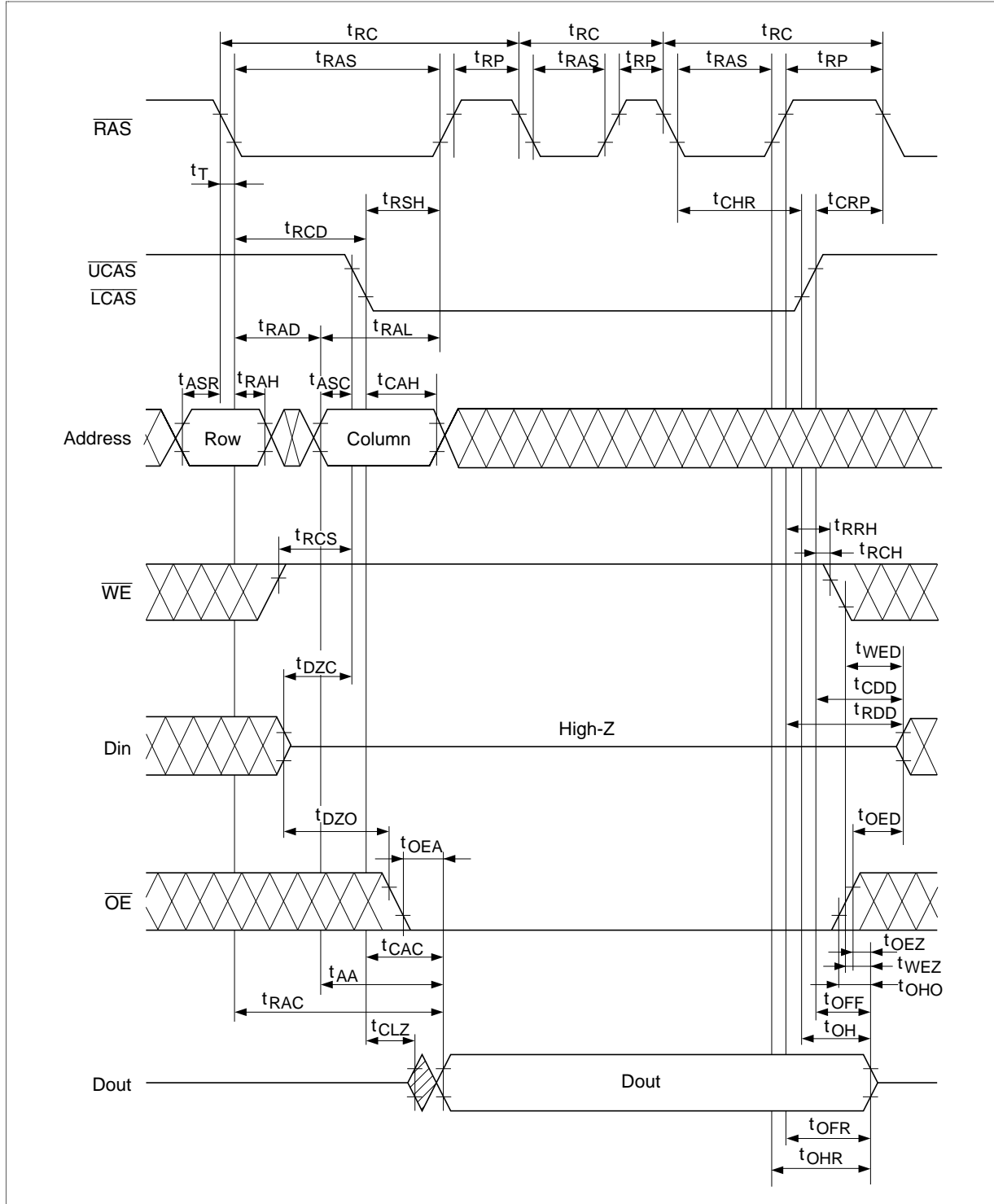

HM5118165B Series

EDO Page Mode Read Cycle

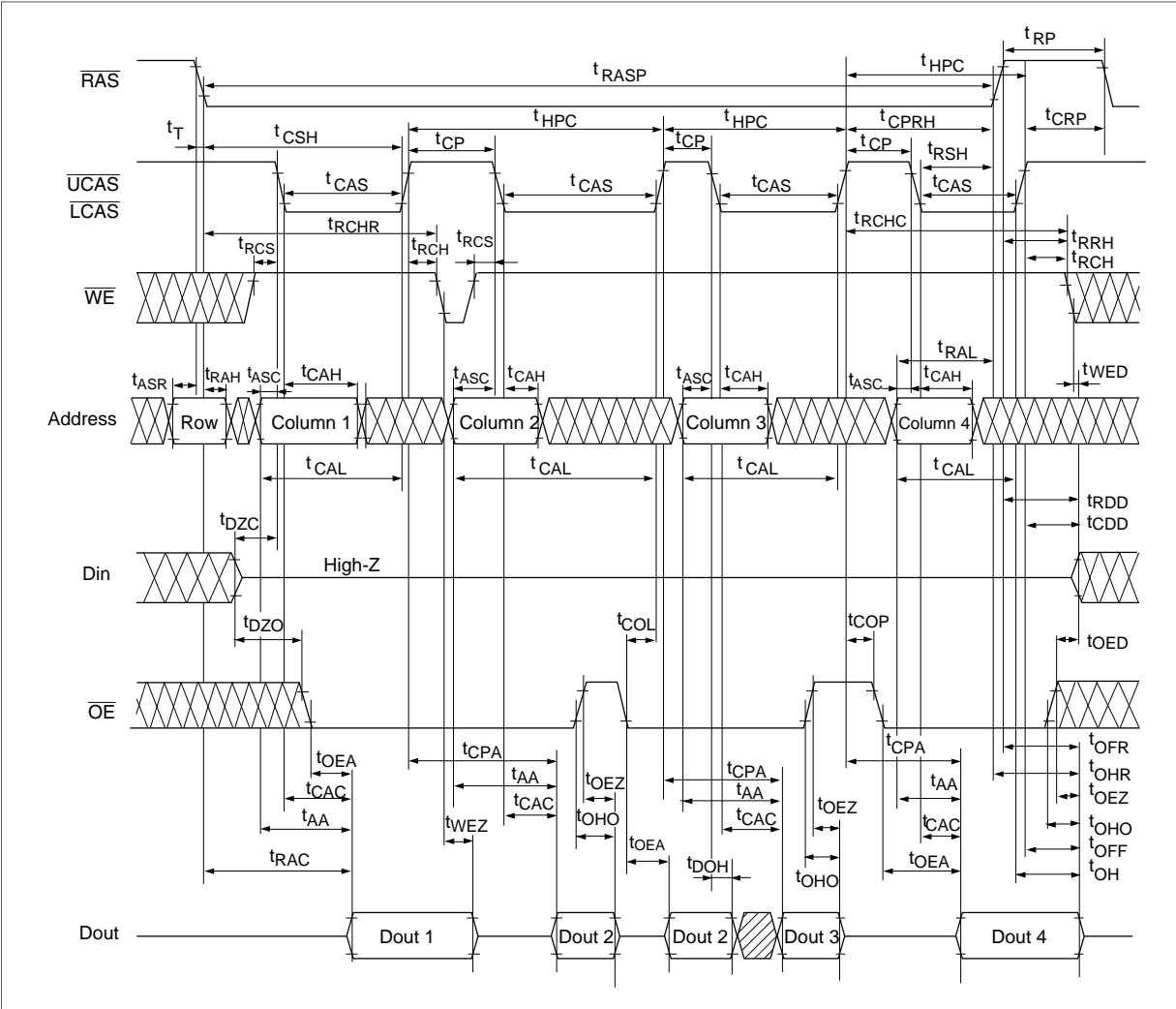

HM5118165B Series

EDO Page Mode Early Write Cycle

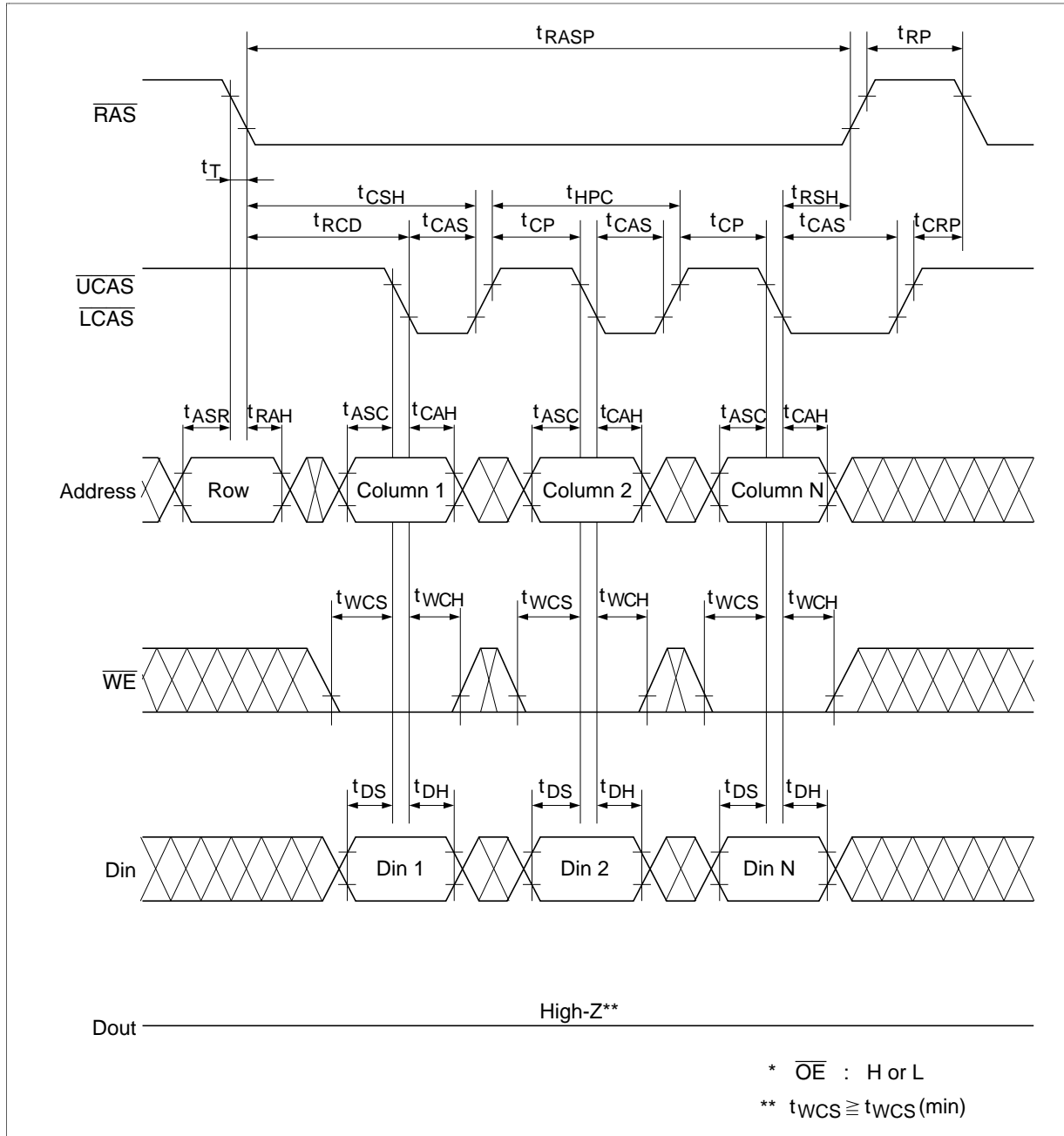

EDO Page Mode Delayed Write Cycle^{*18}

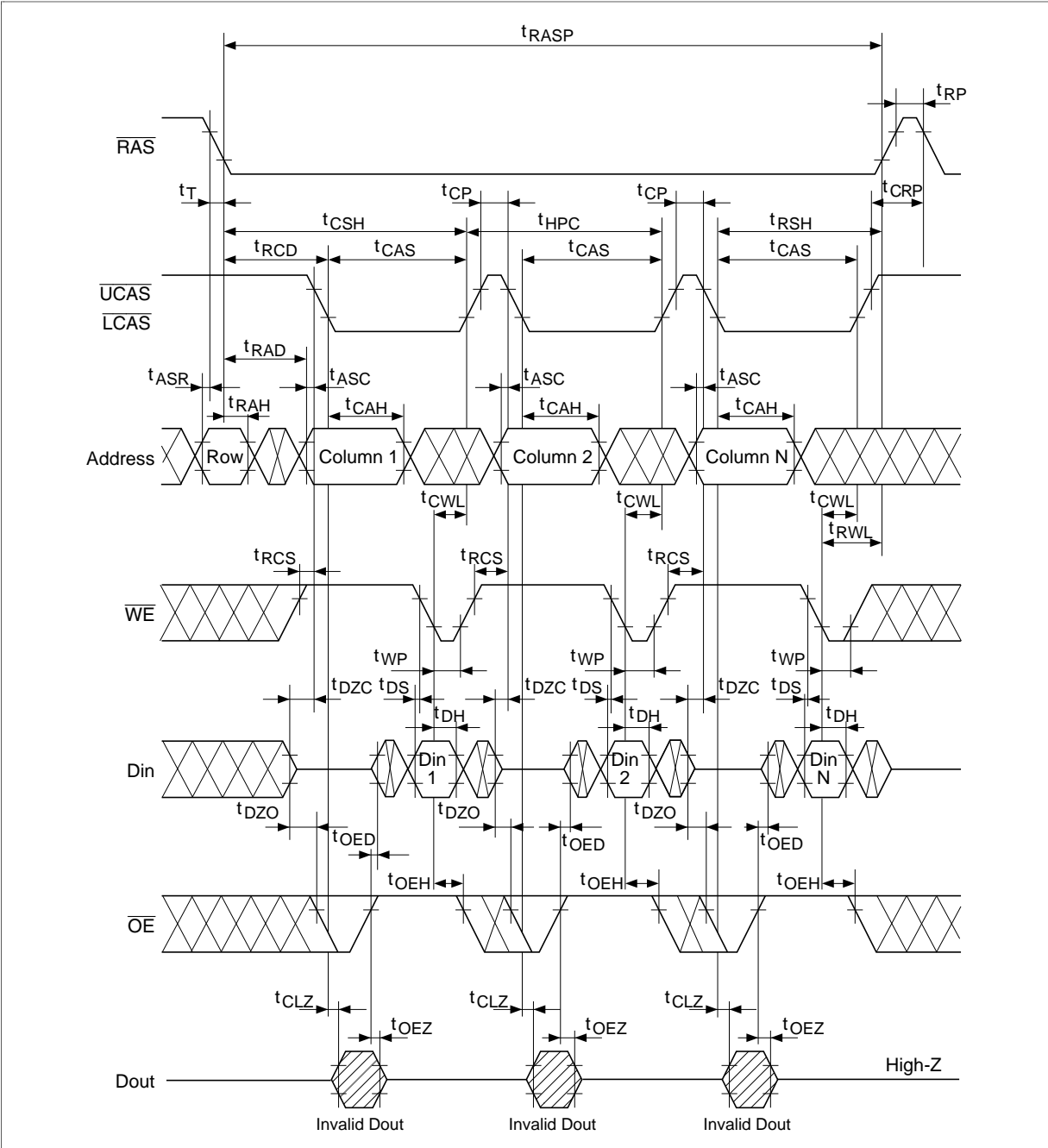

HM5118165B Series

EDO Page Mode Read-Modify-Write Cycle*18

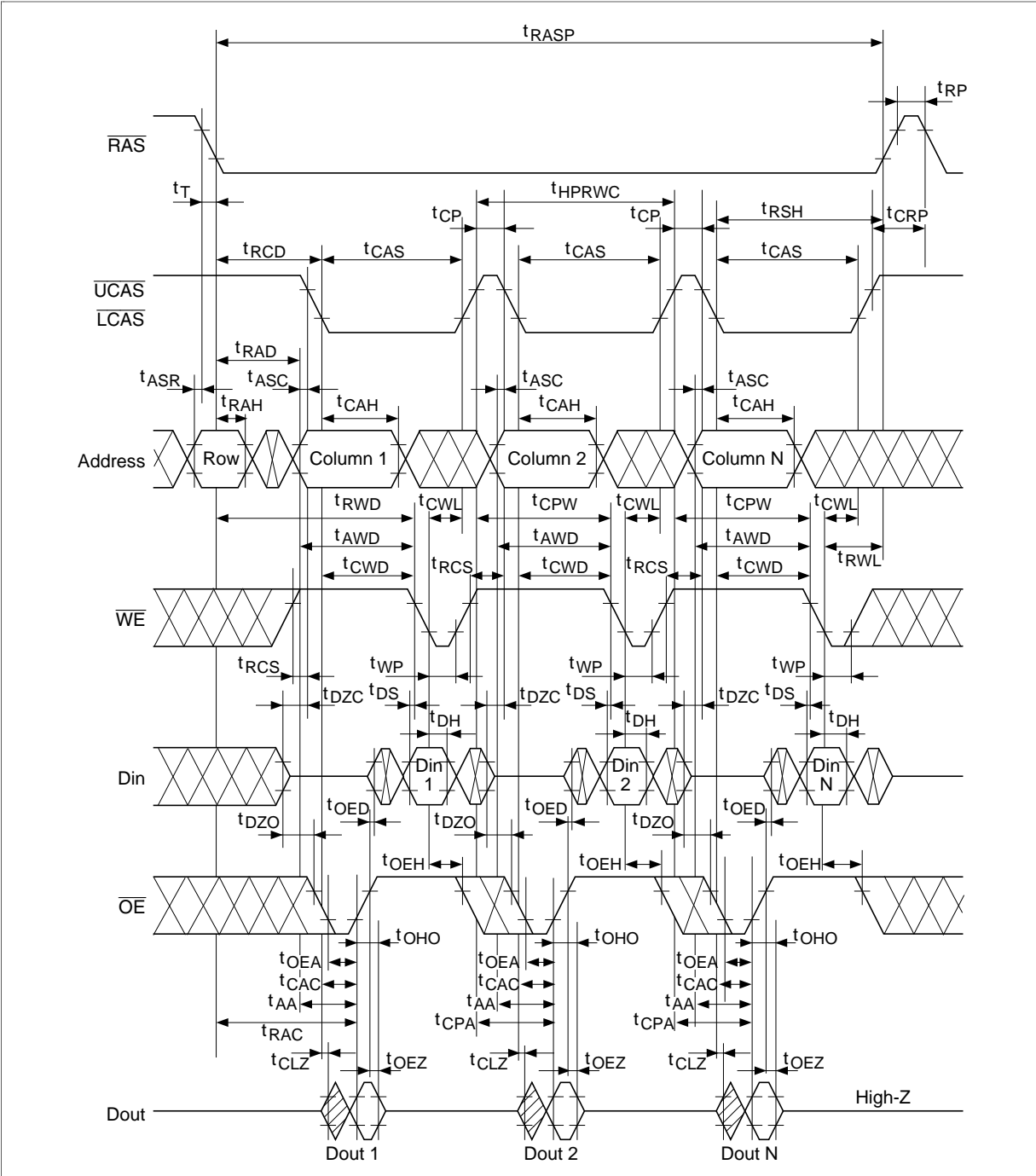

EDO Page Mode Mix Cycle (1)

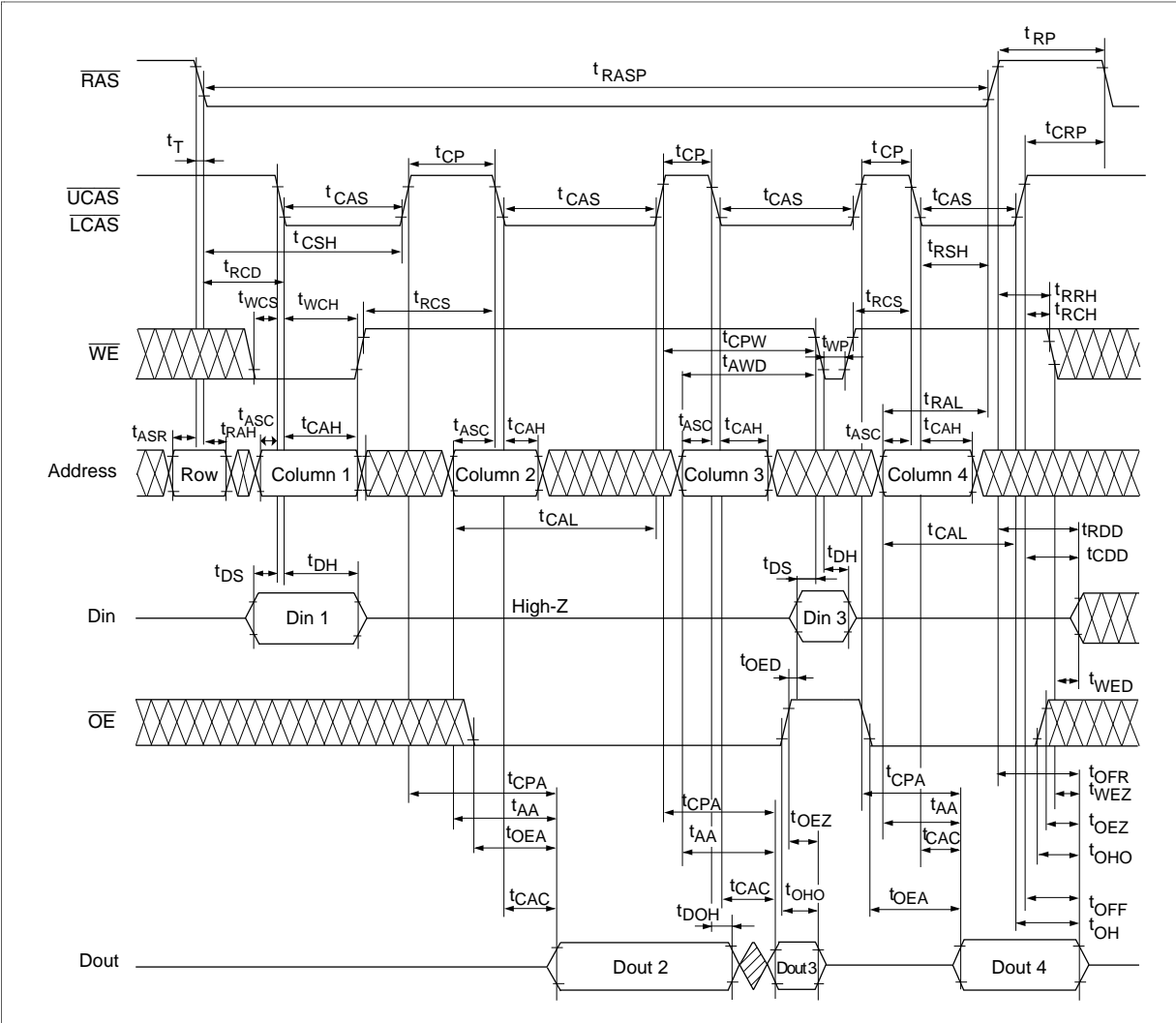

HM5118165B Series

EDO Page Mode Mix Cycle (2)

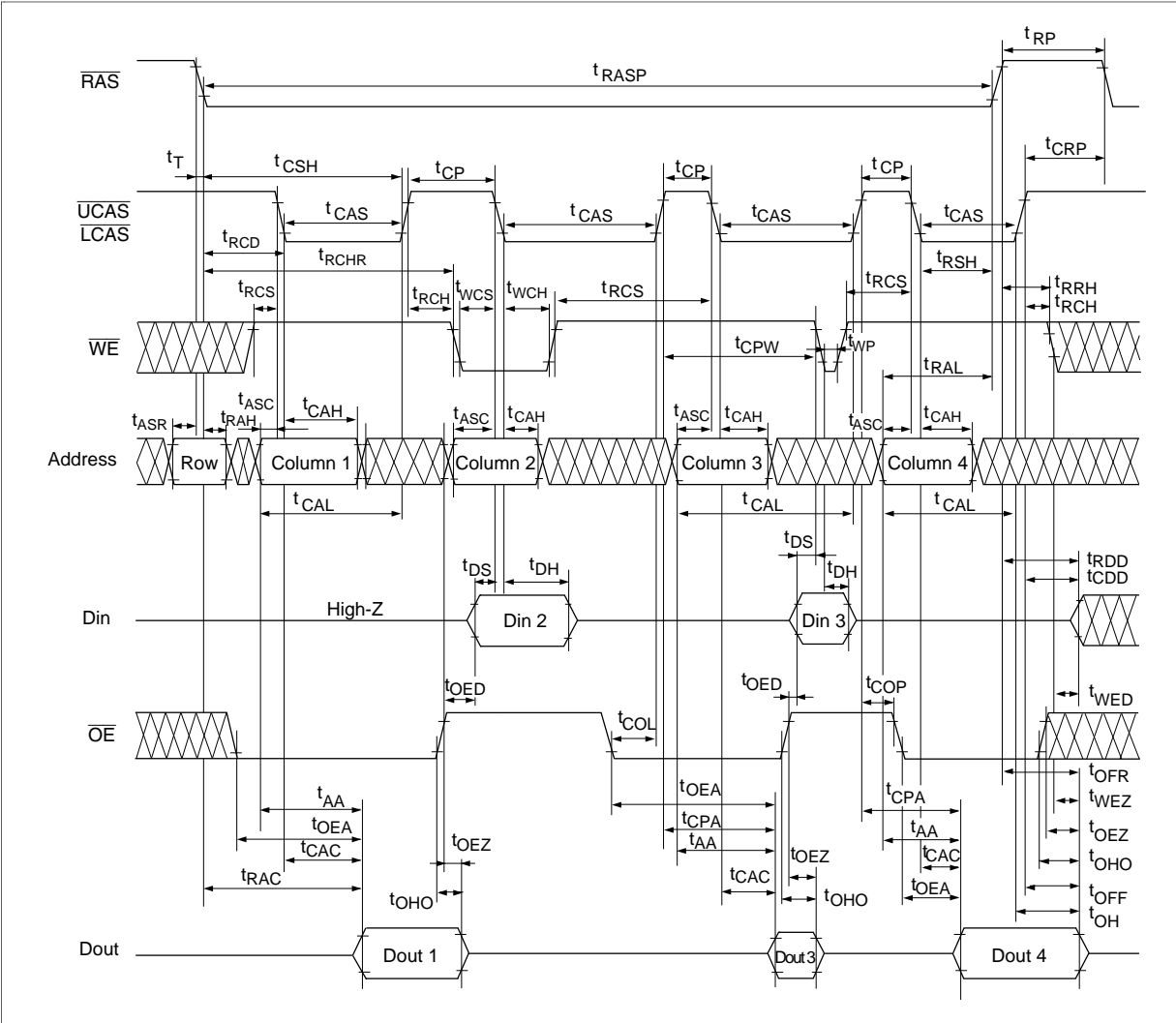

Self Refresh Cycle (L-version)^{*28, 29, 30, 31}

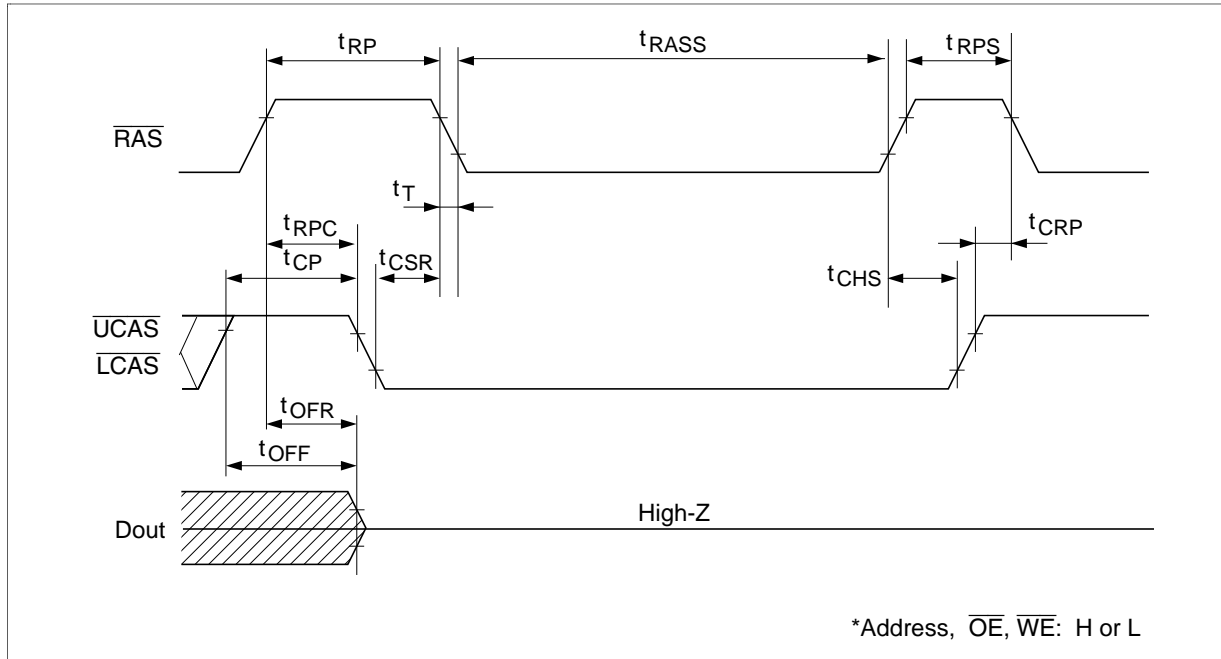

HM5118165B Series

Package Dimensions

HM5118165BJ/ALJ Series (CP-42D)

Unit: mm

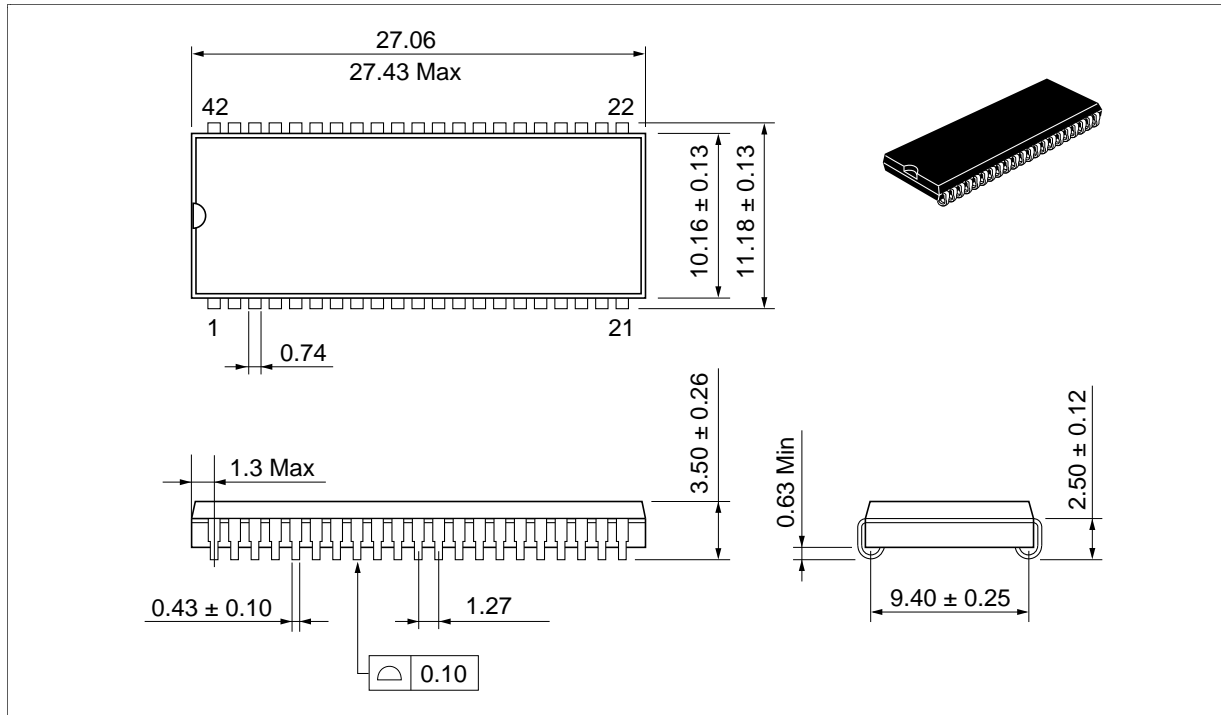

HM5118165B Series

HM5118165BTT/ALTT Series (TTP-50/44DC)

Unit: mm

