HM5117800B Series

2,097,152-word × 8-bit Dynamic Random Access Memory

HITACHI

ADE-203-262A (Z)

Rev. 1.0

Jul. 5, 1996

Description

The Hitachi HM5117800B is a CMOS dynamic RAM organized 2,097,152-word × 8-bit. It employs the most advanced CMOS technology for high performance and low power. The HM5117800B offers Fast Page Mode as a high speed access mode. Multiplexed address input permits the HM5117800B to be packaged in standard 28-pin plastic SOJ and 28-pin TSOP.

Features

- Single 5 V ($\pm 10\%$)
- High speed
 - Access time: 60 ns/70 ns/80 ns (max)
- Low power dissipation
 - Active mode: 660mW/605 mW/550 mW(max)
 - Standby mode : 11 mW (max)
 : 0.83 mW (max) (L-version)
- Fast page mode capability
- Long refresh period
 - 2048 refresh cycles : 32 ms
 : 128 ms (L-version)
- 4 variations of refresh
 - $\overline{\text{RAS}}$ -only refresh
 - $\overline{\text{CAS}}$ -before- $\overline{\text{RAS}}$ refresh
 - Hidden refresh
 - Self refresh (L-version)
- Battery backup operation (L-version)

This specification is fully compatible with the 16-Mbit DRAM specifications from TEXAS INSTRUMENTS.

HM5117800B Series

Ordering Information

Type No.	Access time	Package
HM5117800BJ-6	60 ns	400-mil 28-pin plastic SOJ (CP-28DA)
HM5117800BJ-7	70 ns	
HM5117800BJ-8	80 ns	
HM5117800BLJ-6	60 ns	
HM5117800BLJ-7	70 ns	
HM5117800BLJ-8	80 ns	
HM5117800BS-6*1	60 ns	300-mil 28-pin plastic SOJ (CP-28DNA)
HM5117800BS-7*1	70 ns	
HM5117800BS-8*1	80 ns	
HM5117800BLS-6*1	60 ns	
HM5117800BLS-7*1	70 ns	
HM5117800BLS-8*1	80 ns	
HM5117800BTT-6	60 ns	400-mil 28-pin plastic TSOP II (TTP-28DA)
HM5117800BTT-7	70 ns	
HM5117800BTT-8	80 ns	
HM5117800BLTT-6	60 ns	
HM5117800BLTT-7	70 ns	
HM5117800BLTT-8	80 ns	
HM5117800BTS-6*1	60 ns	300-mil 28-pin plastic TSOP II (TTP-28DB)
HM5117800BTS-7*1	70 ns	
HM5117800BTS-8*1	80 ns	
HM5117800BLTS-6*1	60 ns	
HM5117800BLTS-7*1	70 ns	
HM5117800BLTS-8*1	80 ns	

Note: 1. Under development

HM5117800B Series

Pin Arrangement

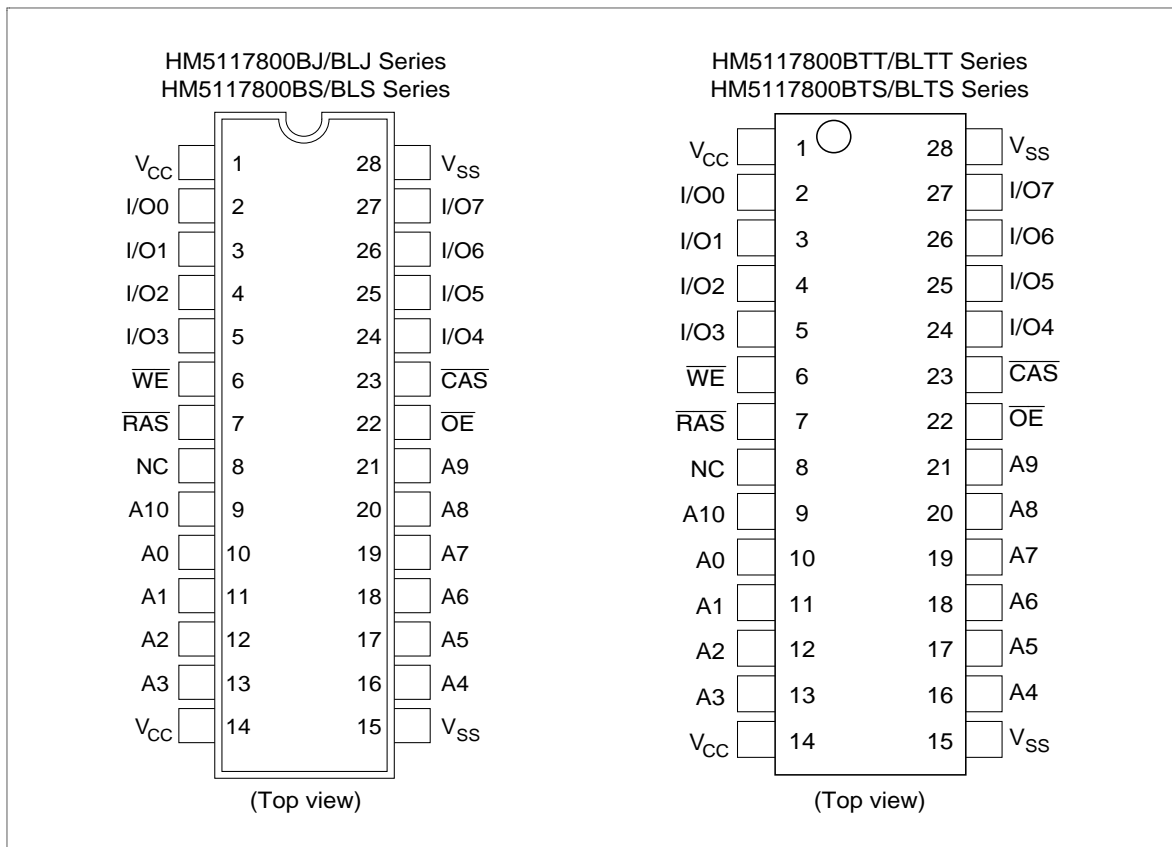

Pin Description

Pin name	Function
A0 to A10	Address input <ul style="list-style-type: none"> • Row/Refresh address A0 to A10 • Column address A0 to A9
I/O0 to I/O7	Data input/data output
\overline{RAS}	Row address strobe
\overline{CAS}	Column address strobe
\overline{WE}	Read/Write enable
\overline{OE}	Output enable
V _{CC}	Power supply
V _{SS}	Ground
NC	No connection

HM5117800B Series

Block Diagram

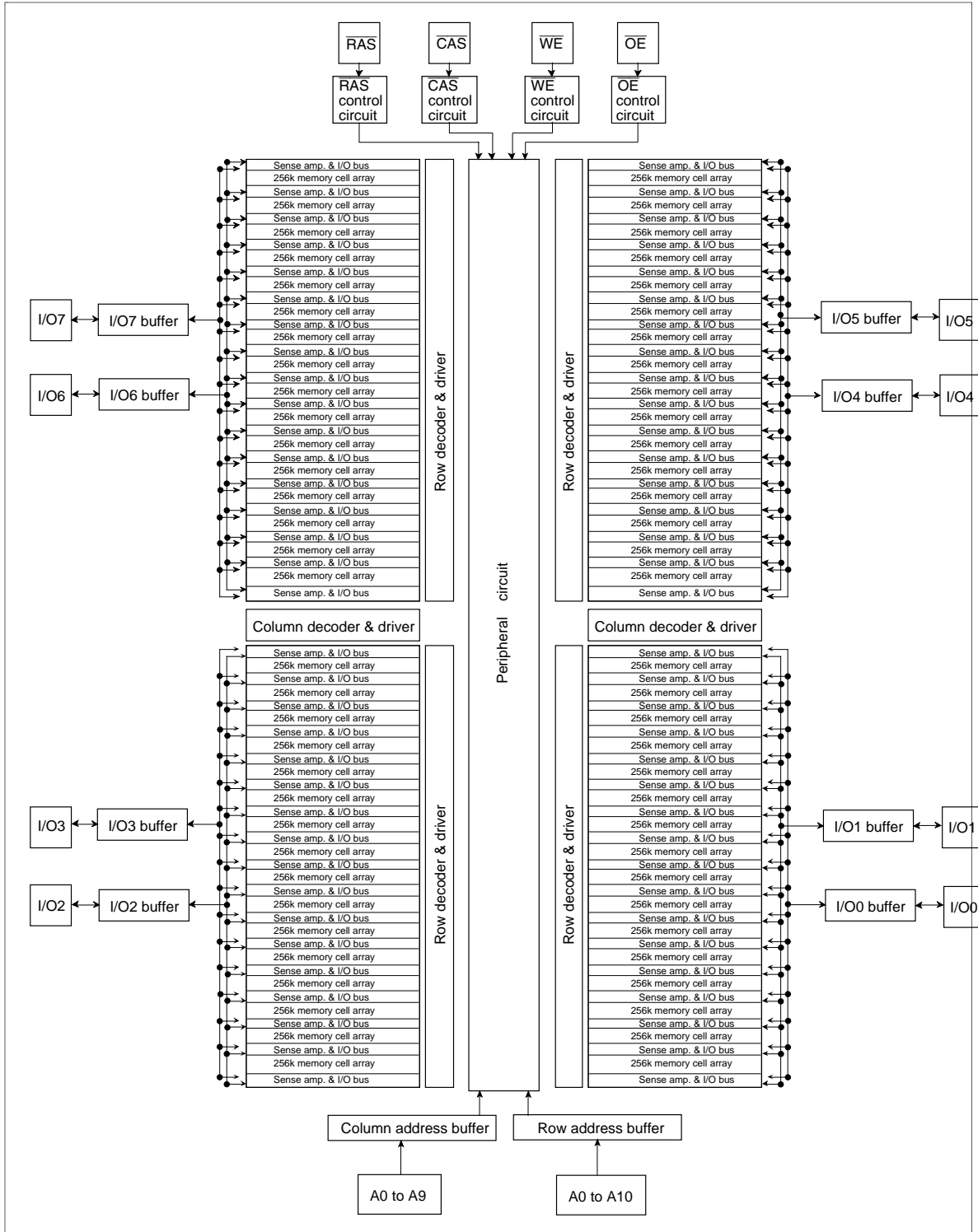

Absolute Maximum Ratings

Parameter	Symbol	Value	Unit
-----------	--------	-------	------

HM5117800B Series

Voltage on any pin relative to V_{SS}	V_T	-1.0 to +7.0	V
Supply voltage relative to V_{SS}	V_{CC}	-1.0 to +7.0	V
Short circuit output current	I_{out}	50	mA
Power dissipation	P_T	1.0	W
Operating temperature	T_{opr}	0 to +70	°C
Storage temperature	T_{stg}	-55 to +125	°C

Recommended DC Operating Conditions ($T_a = 0$ to $+70^\circ\text{C}$)

Parameter	Symbol	Min	Typ	Max	Unit	Note
Supply voltage	V_{CC}	4.5	5.0	5.5	V	1
Input high voltage	V_{IH}	2.4	—	6.5	V	1
Input low voltage	V_{IL}	-1.0	—	0.8	V	1

Note: 1. All voltage referred to V_{SS} .

HM5117800B Series

DC Characteristics (Ta = 0 to +70°C, V_{CC} = 5 V ±10%, V_{SS} = 0 V)

Parameter	Symbol	HM5117800B						Unit	Test conditions
		-6		-7		-8			
		Min	Max	Min	Max	Min	Max		
Operating current ^{1, 2}	I _{CC1}	—	120	—	110	—	100	mA	t _{RC} = min
Standby current	I _{CC2}	—	2	—	2	—	2	mA	TTL interface RAS, CAS = V _{IH} Dout = High-Z
		—	1	—	1	—	1	mA	CMOS interface RAS, CAS ≥ V _{CC} - 0.2V Dout = High-Z
Standby current (L-version)	I _{CC2}	—	150	—	150	—	150	μA	CMOS interface RAS, CAS ≥ V _{CC} - 0.2V Dout = High-Z
RAS-only refresh current ²	I _{CC3}	—	120	—	110	—	100	mA	t _{RC} = min
Standby current ¹	I _{CC5}	—	5	—	5	—	5	mA	RAS = V _{IH} CAS = V _{IL} Dout = enable
CAS-before-RAS refresh current	I _{CC6}	—	120	—	110	—	100	mA	t _{RC} = min
Fast page mode current ^{1, 3}	I _{CC7}	—	100	—	90	—	85	mA	t _{PC} = min
Battery backup current ⁴ (Standby with CBR refresh) (L-version)	I _{CC10}	—	500	—	500	—	500	μA	CMOS interface Dout = High-Z CBR refresh: t _{RC} = 62.5 μs t _{RAS} ≤ 0.3 μs
Self refresh mode current (L-version)	I _{CC11}	—	300	—	300	—	300	μA	CMOS interface RAS, CAS ≤ 0.2V Dout = High-Z
Input leakage current	I _{LI}	-10	10	-10	10	-10	10	μA	0 V ≤ Vin ≤ 7 V
Output leakage current	I _{LO}	-10	10	-10	10	-10	10	μA	0 V ≤ Vout ≤ 7 V Dout = disable
Output high voltage	V _{OH}	2.4	V _{CC}	2.4	V _{CC}	2.4	V _{CC}	V	High Iout = -5 mA
Output low voltage	V _{OL}	0	0.4	0	0.4	0	0.4	V	Low Iout = 4.2 mA

Notes: 1. I_{CC} depends on output load condition when the device is selected. I_{CC} max is specified at the output open condition.

2. Address can be changed once or less while $\overline{\text{RAS}} = V_{\text{IL}}$.

3. Address can be changed once or less while $\overline{\text{CAS}} = V_{\text{IH}}$.

4. $\overline{\text{CAS}} = \text{L}$ (≤ 0.2 V) while $\overline{\text{RAS}} = \text{L}$ (≤ 0.2 V).

HM5117800B Series

Capacitance (Ta = 25°C, V_{CC} = 5 V ± 10%)

Parameter	Symbol	Typ	Max	Unit	Notes
Input capacitance (Address)	C _{I1}	—	5	pF	1
Input capacitance (Clocks)	C _{I2}	—	7	pF	1
Output capacitance (Data-in, Data-out)	C _{I/O}	—	7	pF	1, 2

Notes: 1. Capacitance measured with Boonton Meter or effective capacitance measuring method.
 2. $\overline{\text{CAS}} = V_{\text{IH}}$ to disable Dout.

AC Characteristics (Ta = 0 to +70°C, V_{CC} = 5 V ± 10%, V_{SS} = 0 V)^{*1, *2, *18}

Test Conditions

- Input rise and fall time: 5 ns
- Input timing reference levels: 0.8 V, 2.4 V
- Output load: 2 TTL gate + C_L (100 pF) (Including scope and jig)

Read, Write, Read-Modify-Write and Refresh Cycles (Common parameters)

Parameter	Symbol	HM5117800B						Unit	Notes
		-6		-7		-8			
		Min	Max	Min	Max	Min	Max		
Random read or write cycle time	t _{RC}	110	—	130	—	150	—	ns	
$\overline{\text{RAS}}$ precharge time	t _{RP}	40	—	50	—	60	—	ns	
$\overline{\text{CAS}}$ precharge time	t _{CP}	10	—	10	—	10	—	ns	
$\overline{\text{RAS}}$ pulse width	t _{RAS}	60	10000	70	10000	80	10000	ns	
$\overline{\text{CAS}}$ pulse width	t _{CAS}	15	10000	18	10000	20	10000	ns	
Row address setup time	t _{ASR}	0	—	0	—	0	—	ns	
Row address hold time	t _{RAH}	10	—	10	—	10	—	ns	
Column address setup time	t _{ASC}	0	—	0	—	0	—	ns	
Column address hold time	t _{CAH}	10	—	15	—	15	—	ns	
$\overline{\text{RAS}}$ to $\overline{\text{CAS}}$ delay time	t _{RCD}	20	45	20	52	20	60	ns	3
$\overline{\text{RAS}}$ to column address delay time	t _{RAD}	15	30	15	35	15	40	ns	4
$\overline{\text{RAS}}$ hold time	t _{RSH}	15	—	18	—	20	—	ns	
$\overline{\text{CAS}}$ hold time	t _{CSH}	60	—	70	—	80	—	ns	
$\overline{\text{CAS}}$ to $\overline{\text{RAS}}$ precharge time	t _{CRP}	5	—	5	—	5	—	ns	
$\overline{\text{OE}}$ to Din delay time	t _{OED}	15	—	18	—	20	—	ns	5
$\overline{\text{OE}}$ delay time from Din	t _{DZO}	0	—	0	—	0	—	ns	6
$\overline{\text{CAS}}$ delay time from Din	t _{DZC}	0	—	0	—	0	—	ns	6
Transition time (rise and fall)	t _T	3	50	3	50	3	50	ns	7

HM5117800B Series

Read Cycle

Parameter	Symbol	HM5117800B						Unit	Notes
		-6		-7		-8			
		Min	Max	Min	Max	Min	Max		
Access time from $\overline{\text{RAS}}$	t_{RAC}	—	60	—	70	—	80	ns	8, 9
Access time from $\overline{\text{CAS}}$	t_{CAC}	—	15	—	18	—	20	ns	9, 10, 17
Access time from address	t_{AA}	—	30	—	35	—	40	ns	9, 11, 17
Access time from $\overline{\text{OE}}$	t_{OEA}	—	15	—	18	—	20	ns	9
Read command setup time	t_{RCS}	0	—	0	—	0	—	ns	
Read command hold time to $\overline{\text{CAS}}$	t_{RCH}	0	—	0	—	0	—	ns	12
Read command hold time to $\overline{\text{RAS}}$	t_{RRH}	0	—	0	—	0	—	ns	12
Column address to $\overline{\text{RAS}}$ lead time	t_{RAL}	30	—	35	—	40	—	ns	
Column address to $\overline{\text{CAS}}$ lead time	t_{CAL}	30	—	35	—	40	—	ns	
$\overline{\text{CAS}}$ to output in low-Z	t_{CLZ}	0	—	0	—	0	—	ns	
Output data hold time	t_{OH}	3	—	3	—	3	—	ns	
Output data hold time from $\overline{\text{OE}}$	t_{OHO}	3	—	3	—	3	—	ns	
Output buffer turn-off time	t_{OFF}	—	15	—	15	—	15	ns	13
Output buffer turn-off to $\overline{\text{OE}}$	t_{OEZ}	—	15	—	15	—	15	ns	13
$\overline{\text{CAS}}$ to Din delay time	t_{CDD}	15	—	18	—	20	—	ns	5

Write Cycle

Parameter	Symbol	HM5117800B						Unit	Notes
		-6		-7		-8			
		Min	Max	Min	Max	Min	Max		
Write command setup time	t_{WCS}	0	—	0	—	0	—	ns	14
Write command hold time	t_{WCH}	10	—	15	—	15	—	ns	
Write command pulse width	t_{WP}	10	—	10	—	10	—	ns	
Write command to $\overline{\text{RAS}}$ lead time	t_{RWL}	15	—	18	—	20	—	ns	
Write command to $\overline{\text{CAS}}$ lead time	t_{CWL}	15	—	18	—	20	—	ns	
Data-in setup time	t_{DS}	0	—	0	—	0	—	ns	15
Data-in hold time	t_{DH}	10	—	15	—	15	—	ns	15

HM5117800B Series

Read-Modify-Write Cycle

		HM5117800B							
		-6		-7		-8			
Parameter	Symbol	Min	Max	Min	Max	Min	Max	Unit	Notes
Read-modify-write cycle time	t_{RWC}	155	—	181	—	205	—	ns	
\overline{RAS} to \overline{WE} delay time	t_{RWD}	85	—	98	—	110	—	ns	14
\overline{CAS} to \overline{WE} delay time	t_{CWD}	40	—	46	—	50	—	ns	14
Column address to \overline{WE} delay time	t_{AWD}	55	—	63	—	70	—	ns	14
\overline{OE} hold time from \overline{WE}	t_{OEh}	15	—	18	—	20	—	ns	

Refresh Cycle

		HM5117800B							
		-6		-7		-8			
Parameter	Symbol	Min	Max	Min	Max	Min	Max	Unit	Notes
\overline{CAS} setup time (CBR refresh cycle)	t_{CSR}	5	—	5	—	5	—	ns	
\overline{CAS} hold time (CBR refresh cycle)	t_{CHR}	10	—	10	—	10	—	ns	
\overline{WE} setup time (CBR refresh cycle)	t_{WRP}	0	—	0	—	0	—	ns	
\overline{WE} hold time (CBR refresh cycle)	t_{WRH}	10	—	10	—	10	—	ns	
\overline{RAS} precharge to \overline{CAS} hold time	t_{RPC}	0	—	0	—	0	—	ns	

Fast Page Mode Cycle

		HM5117800B							
		-6		-7		-8			
Parameter	Symbol	Min	Max	Min	Max	Min	Max	Unit	Notes
Fast page mode cycle time	t_{PC}	40	—	45	—	50	—	ns	
Fast page mode \overline{RAS} pulse width	t_{RASP}	—	100000	—	100000	—	100000	ns	16
Access time from \overline{CAS} precharge	t_{CPA}	—	35	—	40	—	45	ns	9, 17
\overline{RAS} hold time from \overline{CAS} precharge	t_{CPRH}	35	—	40	—	45	—	ns	

Fast Page Mode Read-Modify-Write Cycle

		HM5117800B							
		-6		-7		-8			
Parameter	Symbol	Min	Max	Min	Max	Min	Max	Unit	Notes
Fast page mode read- modify-write cycle time	t_{PRWC}	85	—	96	—	105	—	ns	
\overline{WE} delay time from \overline{CAS} precharge	t_{CPW}	60	—	68	—	75	—	ns	14

HM5117800B Series

Refresh

Parameter	Symbol	Max	Unit	Note
Refresh period	t_{REF}	32	ms	2048 cycles
Refresh period (L-version)	t_{REF}	128	ms	2048 cycles

HM5117800B Series

Self Refresh Mode (L-version)

Parameter	Symbol	HM5117800BL						Unit	Notes
		-6		-7		-8			
		Min	Max	Min	Max	Min	Max		
$\overline{\text{RAS}}$ pulse width (self refresh)	t_{RASS}	100	—	100	—	100	—	μs	
$\overline{\text{RAS}}$ precharge time (self refresh)	t_{RPS}	110	—	130	—	150	—	ns	
$\overline{\text{CAS}}$ hold time (self refresh)	t_{CHS}	-50	—	-50	—	-50	—	ns	

- Notes:
- AC measurements assume $t_r = 5$ ns.
 - An initial pause of 200 μs is required after power up followed by a minimum of eight initialization cycles (any combination of cycles containing $\overline{\text{RAS}}$ -only refresh or $\overline{\text{CAS}}$ -before- $\overline{\text{RAS}}$ refresh). If the internal refresh counter is used, a minimum of eight $\overline{\text{CAS}}$ -before- $\overline{\text{RAS}}$ refresh cycles are required.
 - Operation with the t_{RCD} (max) limit insures that t_{RAC} (max) can be met, t_{RCD} (max) is specified as a reference point only; if t_{RCD} is greater than the specified t_{RCD} (max) limit, then access time is controlled exclusively by t_{CAC} .
 - Operation with the t_{RAD} (max) limit insures that t_{RAC} (max) can be met, t_{RAD} (max) is specified as a reference point only; if t_{RAD} is greater than the specified t_{RAD} (max) limit, then access time is controlled exclusively by t_{AA} .
 - Either t_{OED} or t_{CDD} must be satisfied.
 - Either t_{DZO} or t_{DZC} must be satisfied.
 - V_{IH} (min) and V_{IL} (max) are reference levels for measuring timing of input signals. Also, transition times are measured between V_{IH} (min) and V_{IL} (max).
 - Assumes that $t_{\text{RCD}} \leq t_{\text{RCD}}$ (max) and $t_{\text{RAD}} \leq t_{\text{RAD}}$ (max). If t_{RCD} or t_{RAD} is greater than the maximum recommended value shown in this table, t_{RAC} exceeds the value shown.
 - Measured with a load circuit equivalent to 2 TTL loads and 100 pF.
 - Assumes that $t_{\text{RCD}} \geq t_{\text{RCD}}$ (max) and $t_{\text{RAD}} \leq t_{\text{RAD}}$ (max).
 - Assumes that $t_{\text{RCD}} \leq t_{\text{RCD}}$ (max) and $t_{\text{RAD}} \geq t_{\text{RAD}}$ (max).
 - Either t_{RCH} or t_{RRH} must be satisfied for a read cycles.
 - t_{OFF} (max) and $t_{\text{O EZ}}$ (max) define the time at which the outputs achieve the open circuit condition and are not referred to output voltage levels.
 - t_{WCS} , t_{RWD} , t_{CWD} , t_{AWD} and t_{CPW} are not restrictive operating parameters. They are included in the data sheet as electrical characteristics only; if $t_{\text{WCS}} \geq t_{\text{WCS}}$ (min), the cycle is an early write cycle and the data out pin will remain open circuit (high impedance) throughout the entire cycle; if $t_{\text{RWD}} \geq t_{\text{RWD}}$ (min), $t_{\text{CWD}} \geq t_{\text{CWD}}$ (min), and $t_{\text{AWD}} \geq t_{\text{AWD}}$ (min), or $t_{\text{CWD}} \geq t_{\text{CWD}}$ (min), $t_{\text{AWD}} \geq t_{\text{AWD}}$ (min) and $t_{\text{CPW}} \geq t_{\text{CPW}}$ (min), the cycle is a read-modify-write and the data output will contain data read from the selected cell; if neither of the above sets of conditions is satisfied, the condition of the data out (at access time) is indeterminate.
 - These parameters are referred to $\overline{\text{CAS}}$ leading edge in early write cycles and to $\overline{\text{WE}}$ leading edge in delayed write or read-modify-write cycles.
 - t_{RASP} defines $\overline{\text{RAS}}$ pulse width in Fast page mode cycles.
 - Access time is determined by the longest among t_{AA} , t_{CAC} and t_{CPA} .
 - In delayed write or read-modify-write cycles, $\overline{\text{OE}}$ must disable output buffer prior to applying data to the device.
 - Please do not use t_{RASS} timing, $10 \mu\text{s} \leq t_{\text{RASS}} \leq 100 \mu\text{s}$. During this period, the device is in transition state from normal operation mode to self refresh mode. If $t_{\text{RASS}} \geq 100 \mu\text{s}$, then $\overline{\text{RAS}}$ precharge time should use t_{RPS} instead of t_{RP} .
 - If you use $\overline{\text{RAS}}$ only refresh or CBR burst refresh mode in normal read/write cycles, 2048 cycles of distributed CBR refresh with 15.6 Ms interval should be executed within 32 ms immediately after exiting from and before entering into the self refresh mode.

HM5117800B Series

21. If you use distributed CBR refresh mode with 15.6 μ s interval in normal read/write cycle, CBR refresh should be executed within 15.6 μ s immediately after exiting from and before entering into self refresh mode.
22. Repetitive self refresh mode without refreshing all memory is not allowed. Once you exit from self refresh mode, all memory cells need to be refreshed before re-entering the self refresh mode again.
23. XXX: H or L (H: $V_{IH}(\min) \leq V_{IN} \leq V_{IH}(\max)$, L: $V_{IL}(\min) \leq V_{IN} \leq V_{IL}(\max)$)
///: Invalid Dout
When the address, clock and input pins are not described on timing waveforms, their pins must be applied V_{IH} or V_{IL} .

Timing Waveforms*23

Read Cycle

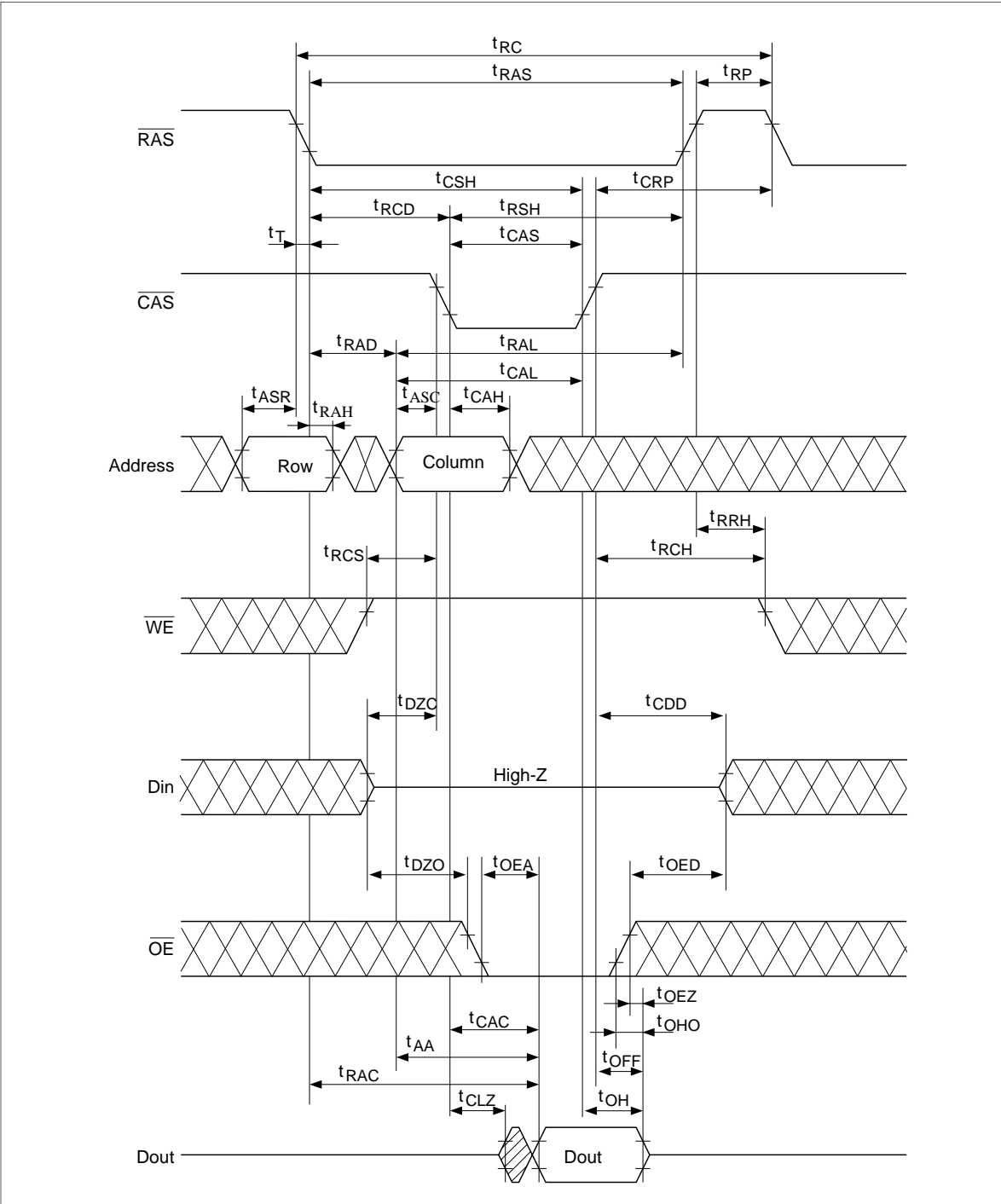

Early Write Cycle

HM5117800B Series

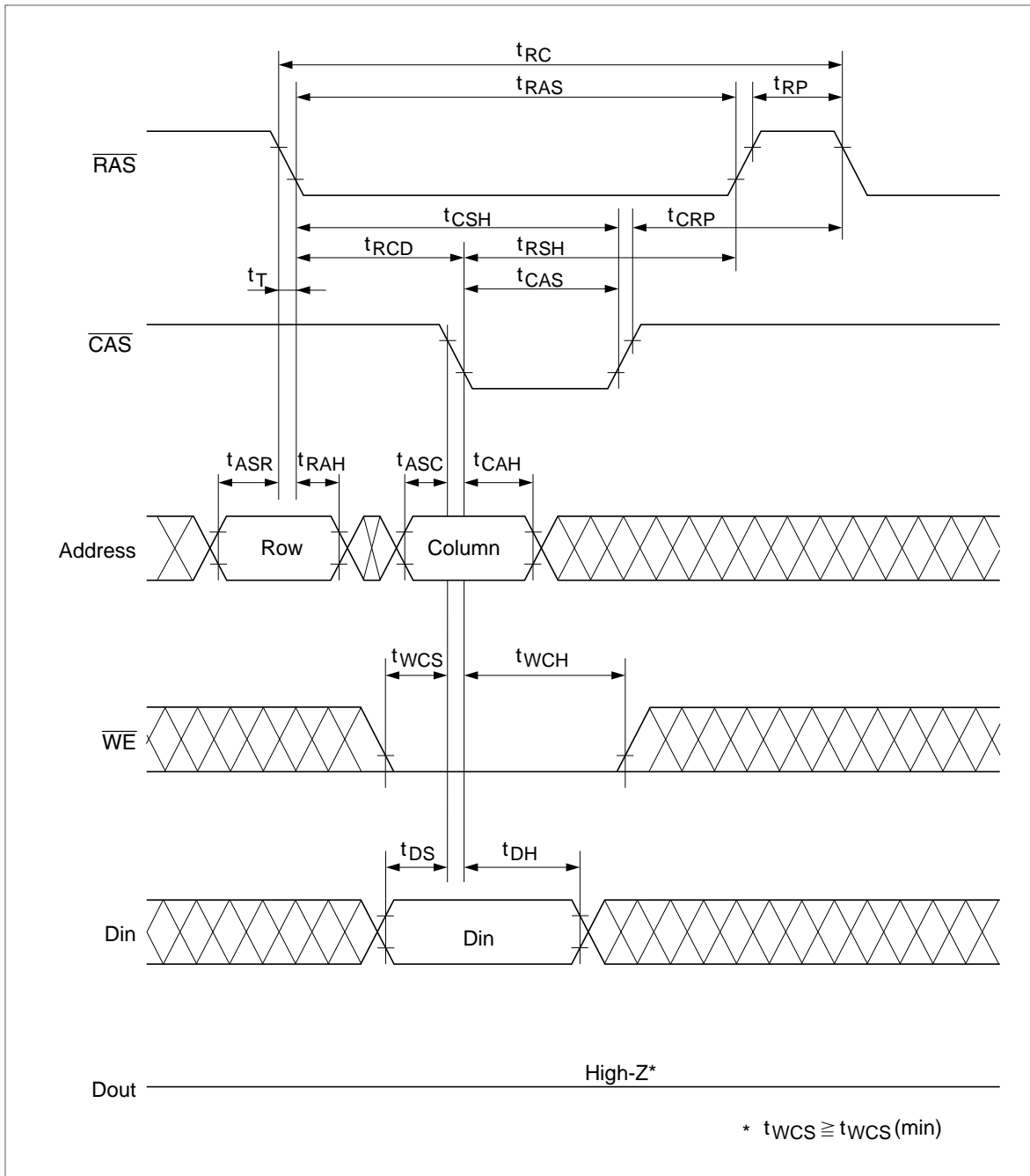

Delayed Write Cycle*18

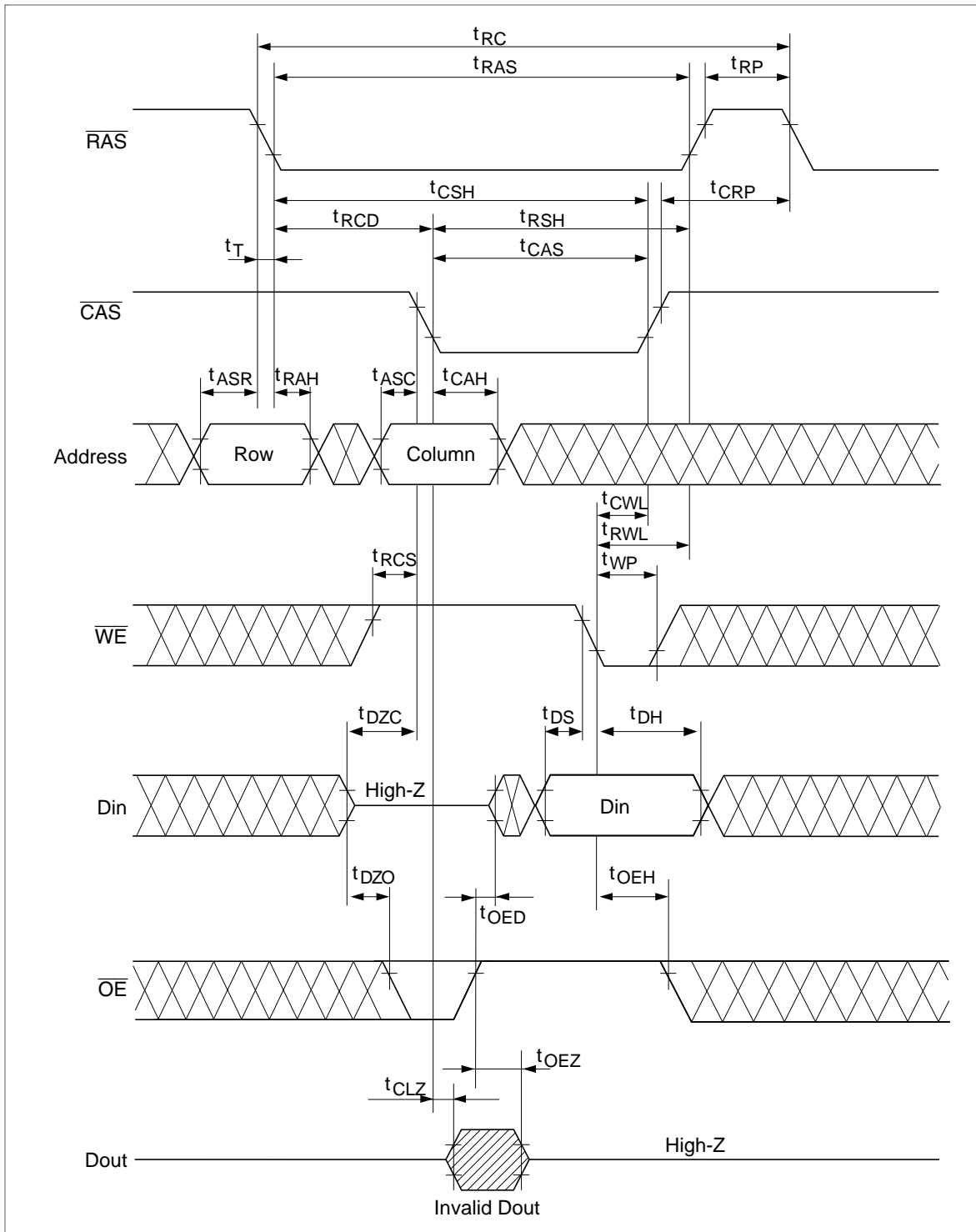

Read-Modify-Write Cycle*18

HM5117800B Series

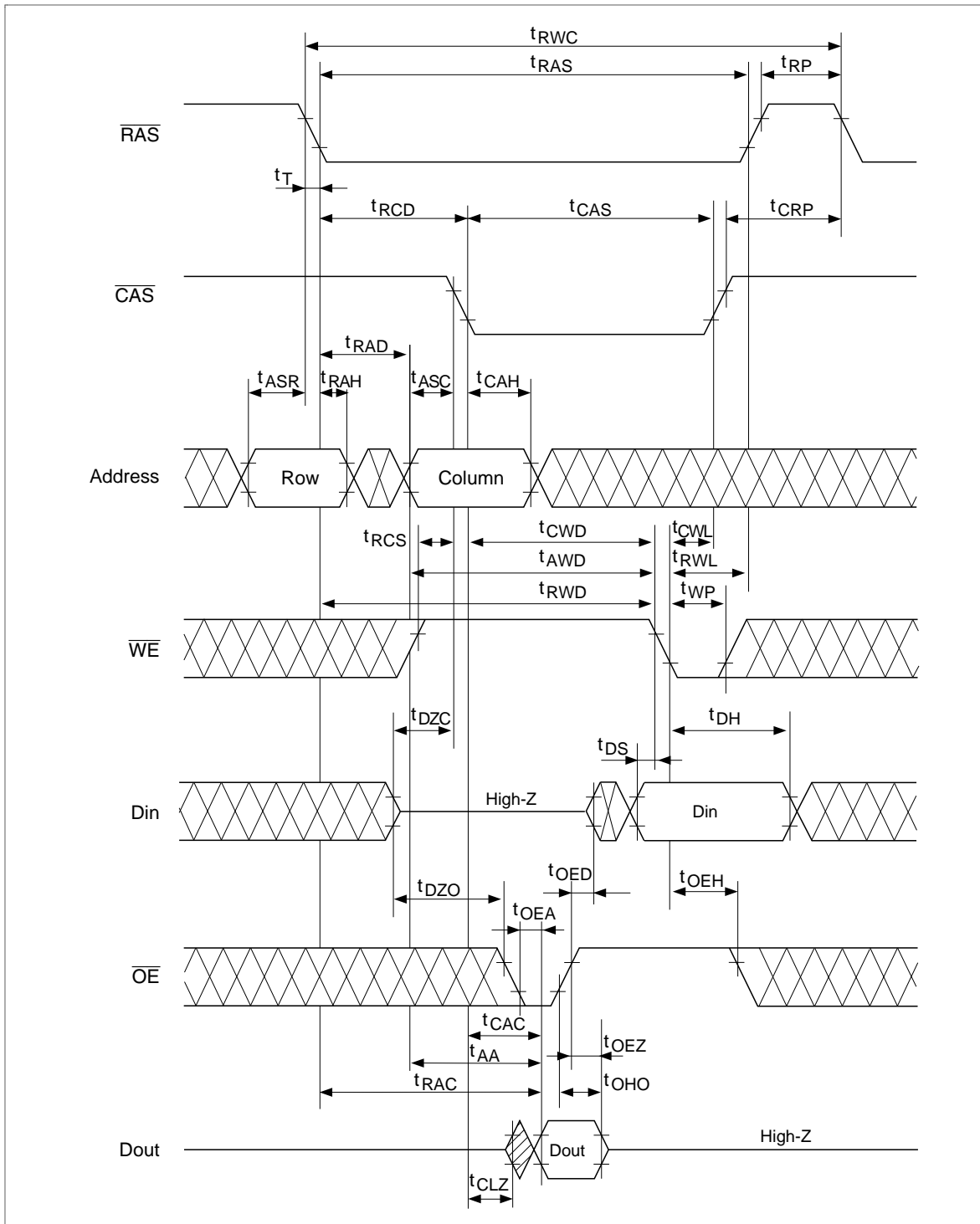

RAS-Only Refresh Cycle

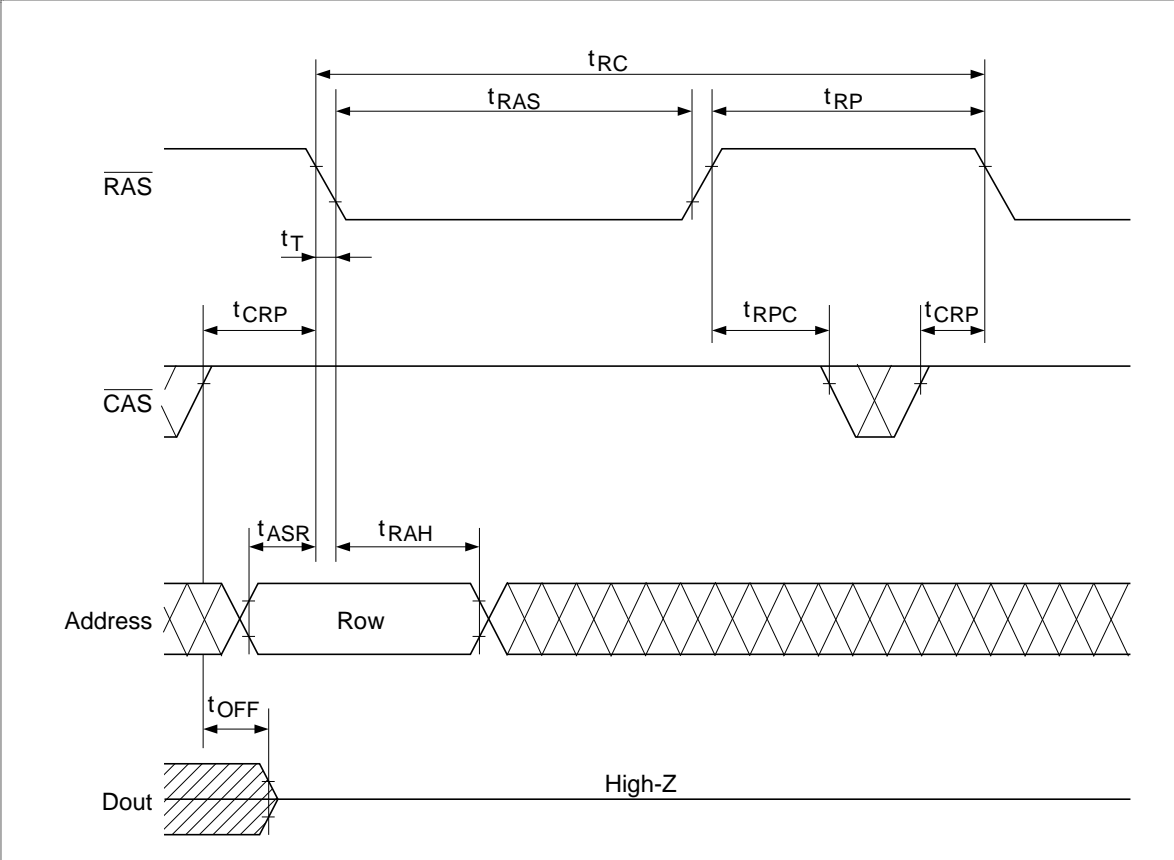

HM5117800B Series

$\overline{\text{CAS}}$ -Before- $\overline{\text{RAS}}$ Refresh Cycle

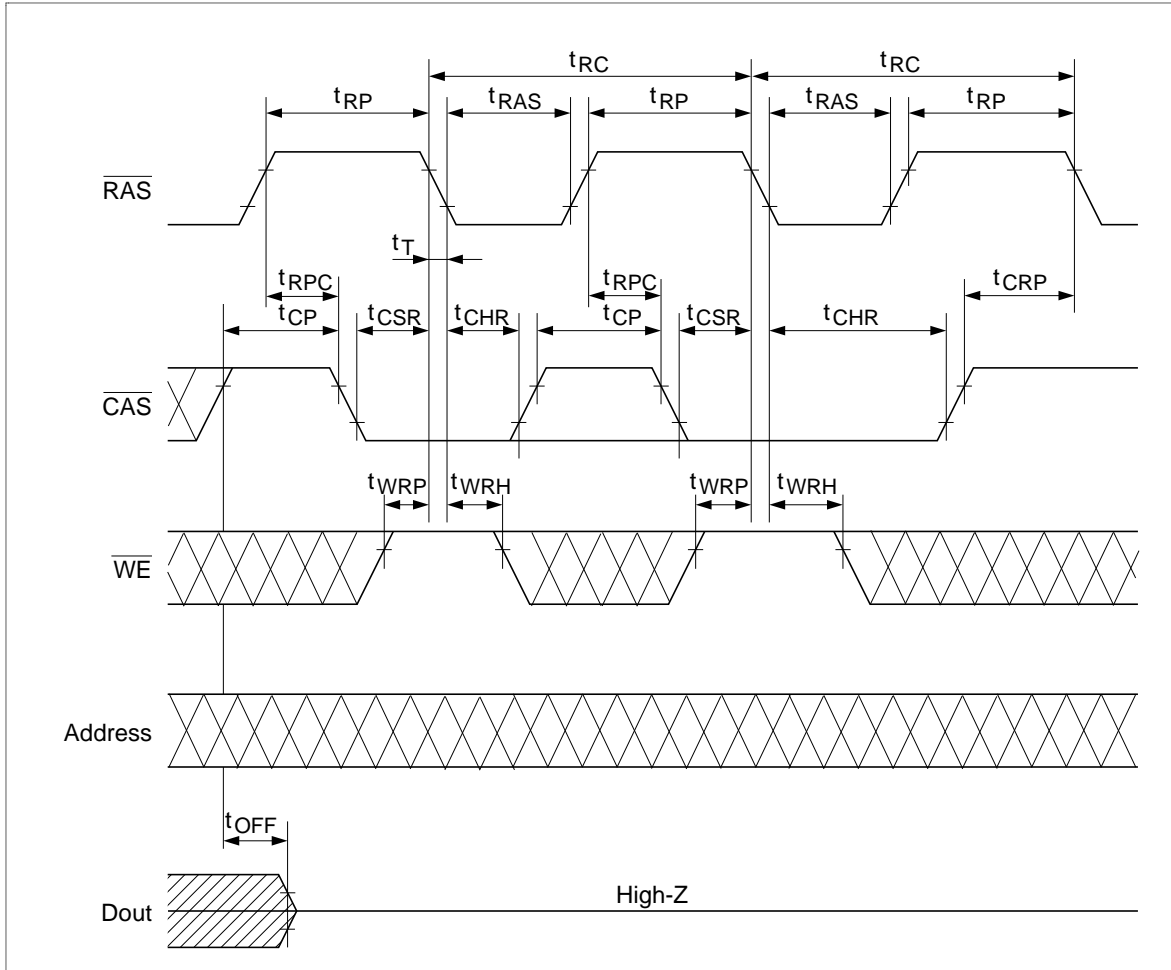

Hidden Refresh Cycle

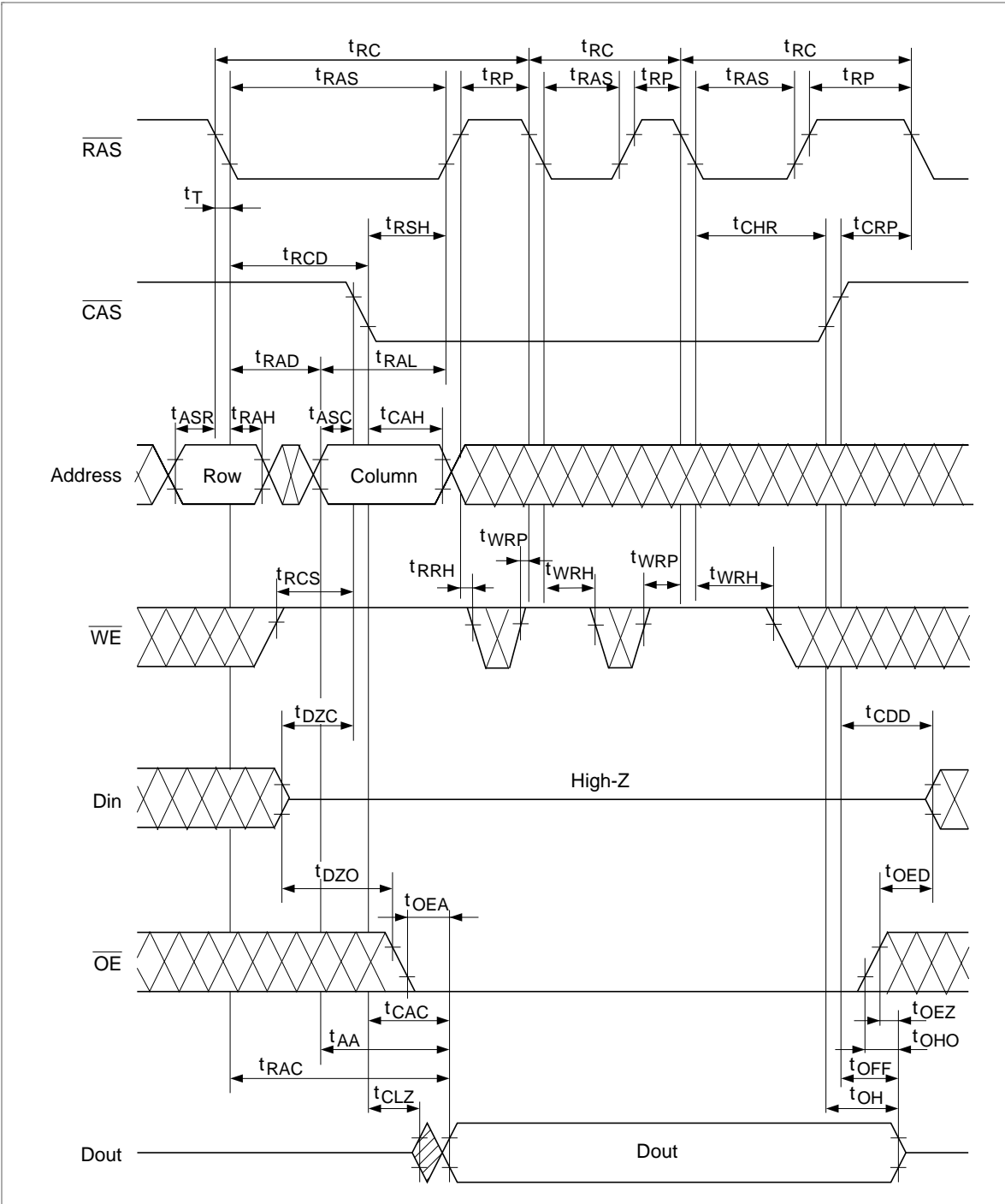

HM5117800B Series

Fast Page Mode Read Cycle

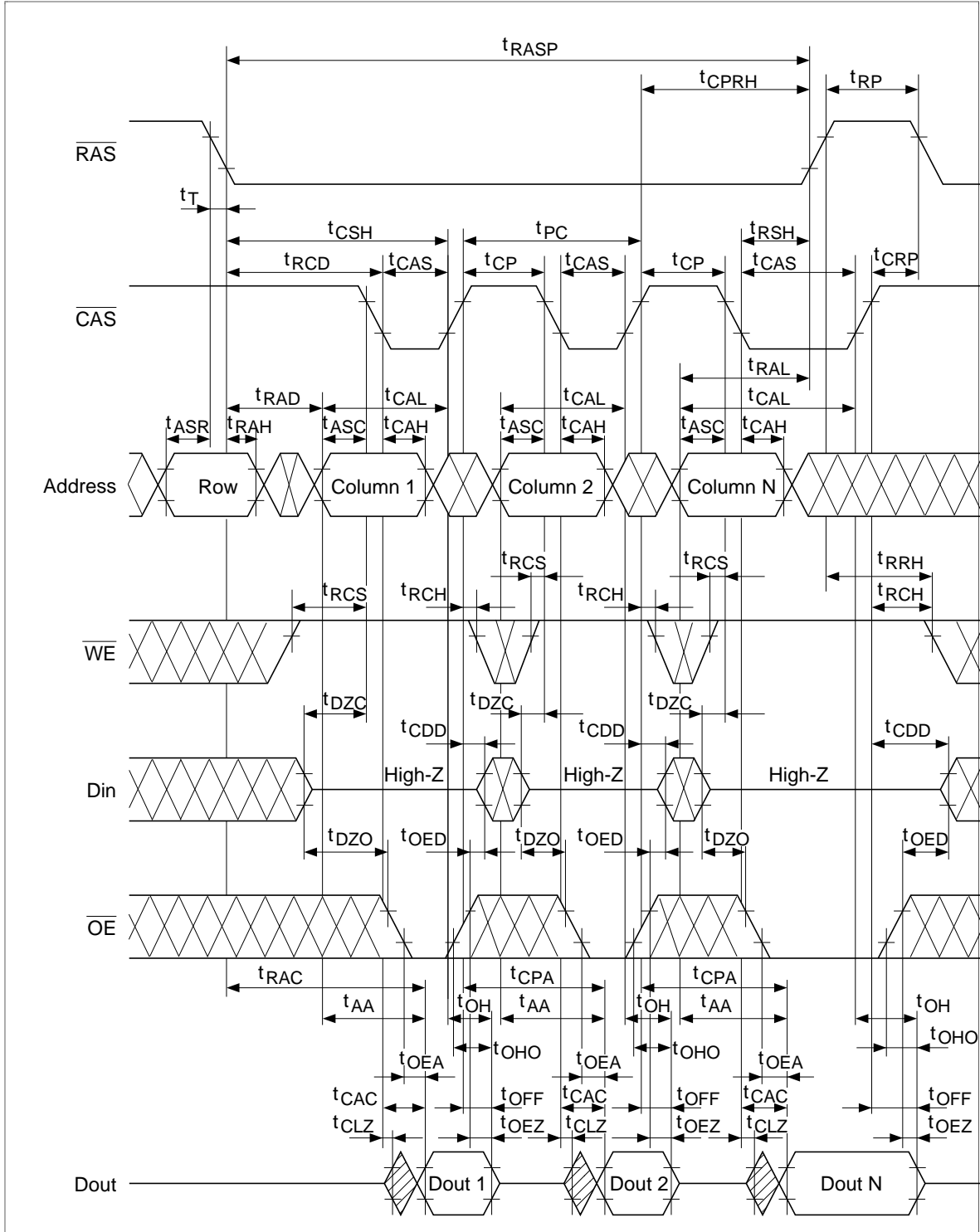

Fast Page Mode Early Write Cycle

HM5117800B Series

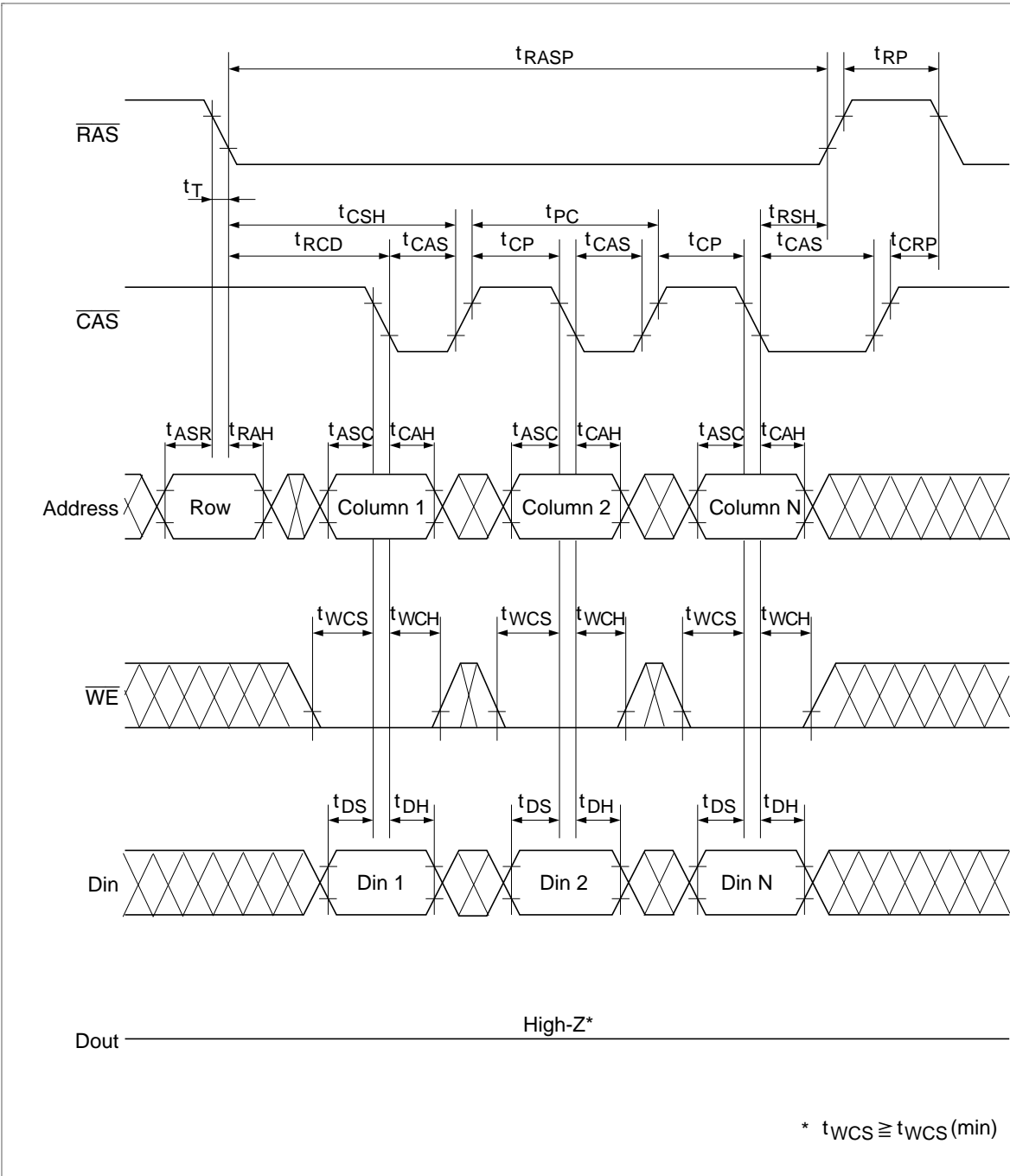

HM5117800B Series

Fast Page Mode Delayed Write Cycle^{*18}

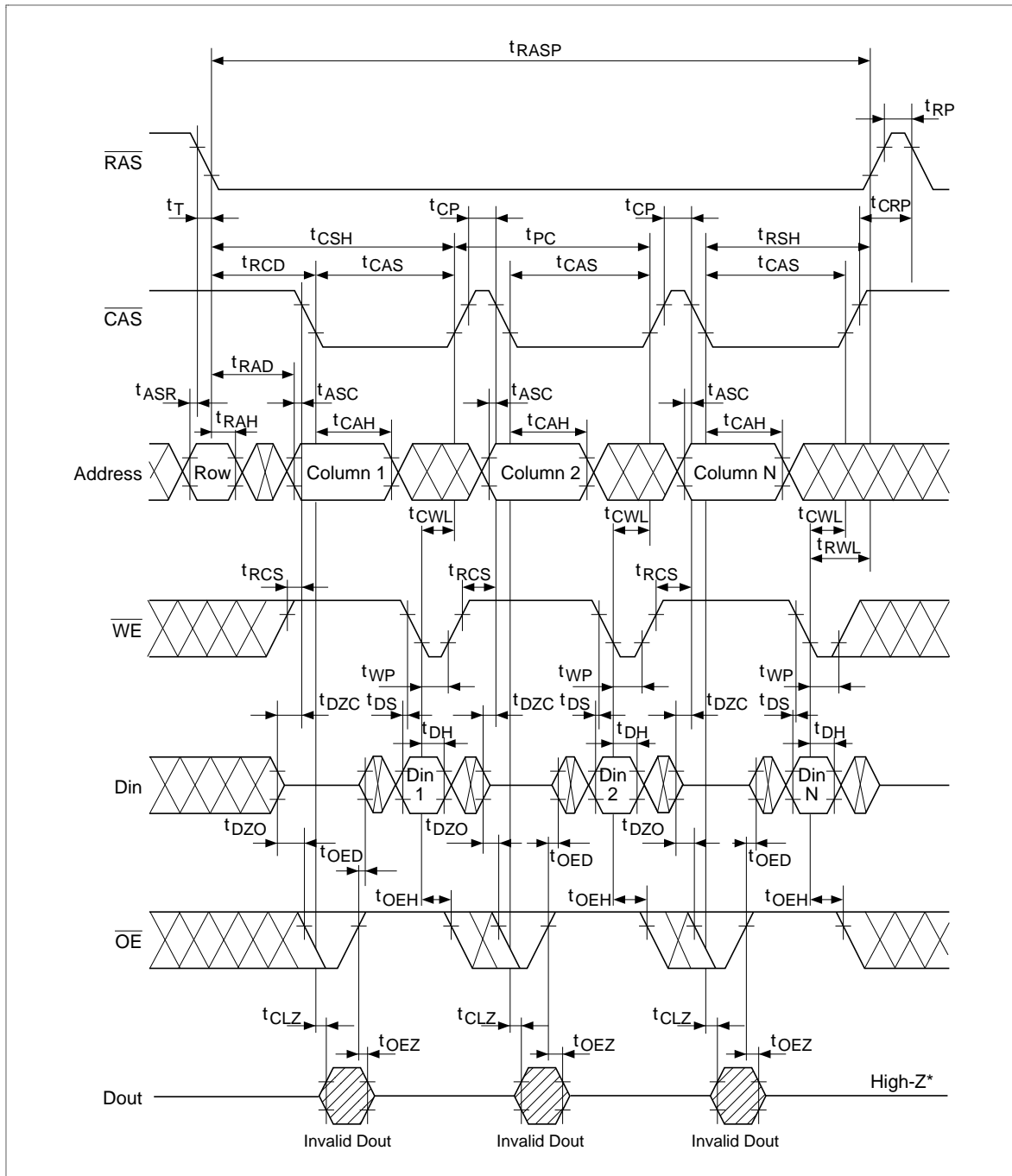

Fast Page Mode Read-Modify-Write Cycle *18

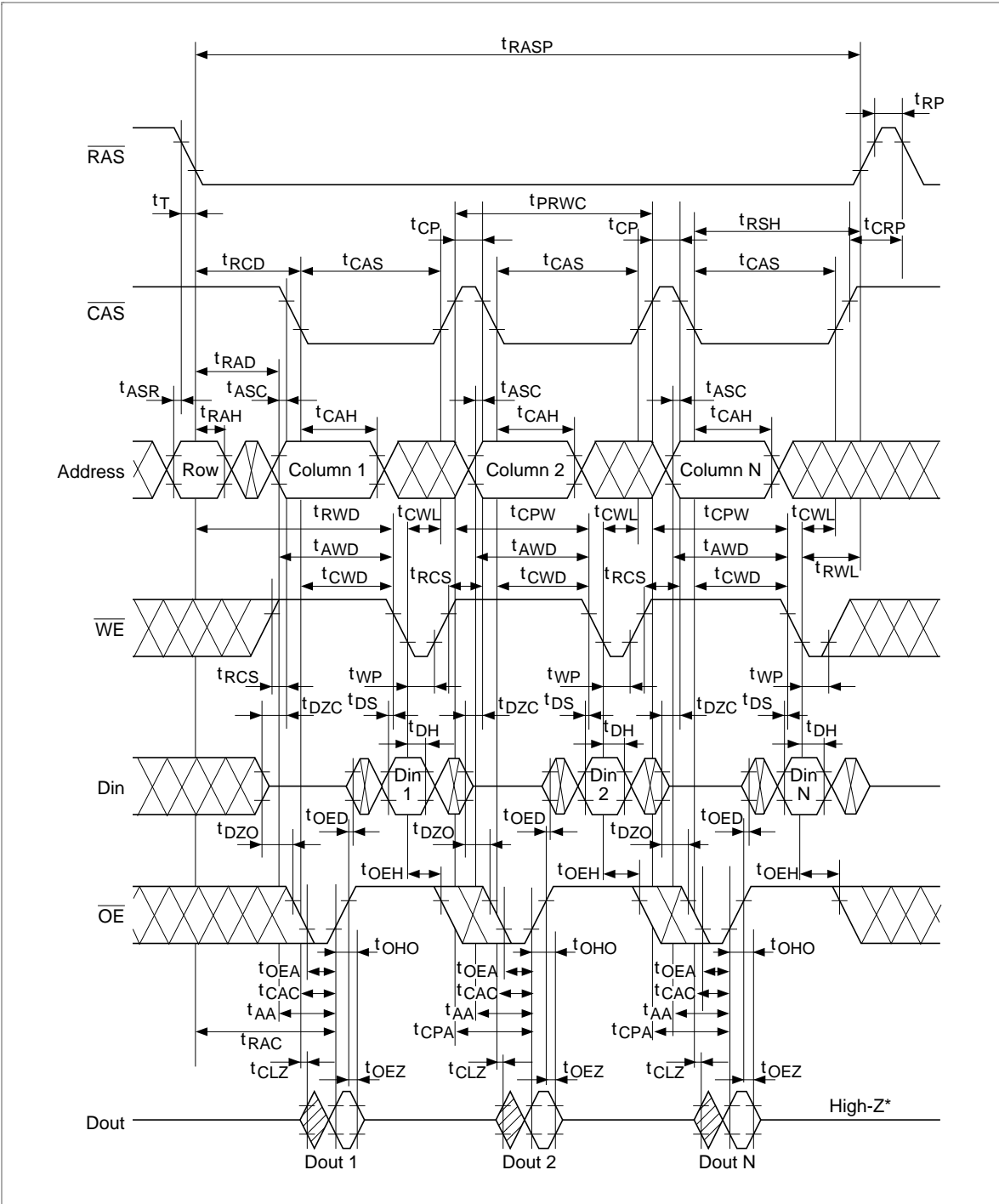

HM5117800B Series

Self Refresh Cycle (L-version)*19, 20, 21, 22

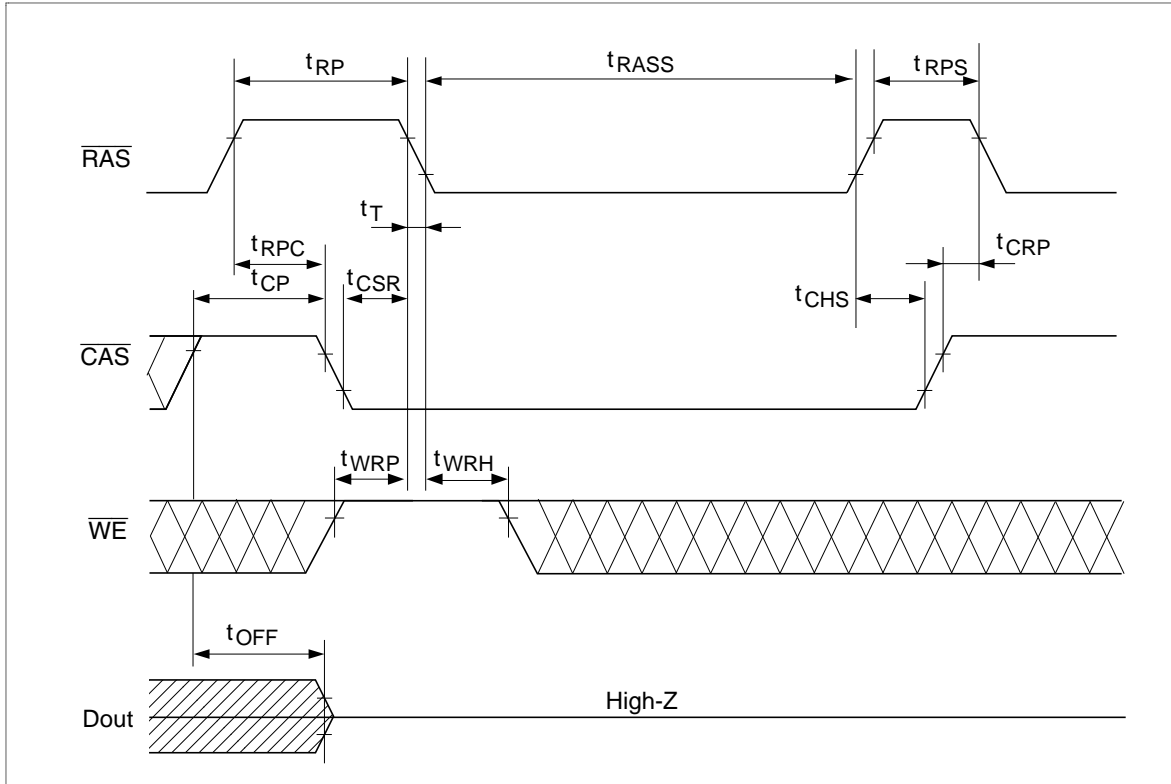

HM5117800B Series

Package Dimensions

HM5117800BJ/BLJ Series (CP-28DA)

Unit: mm

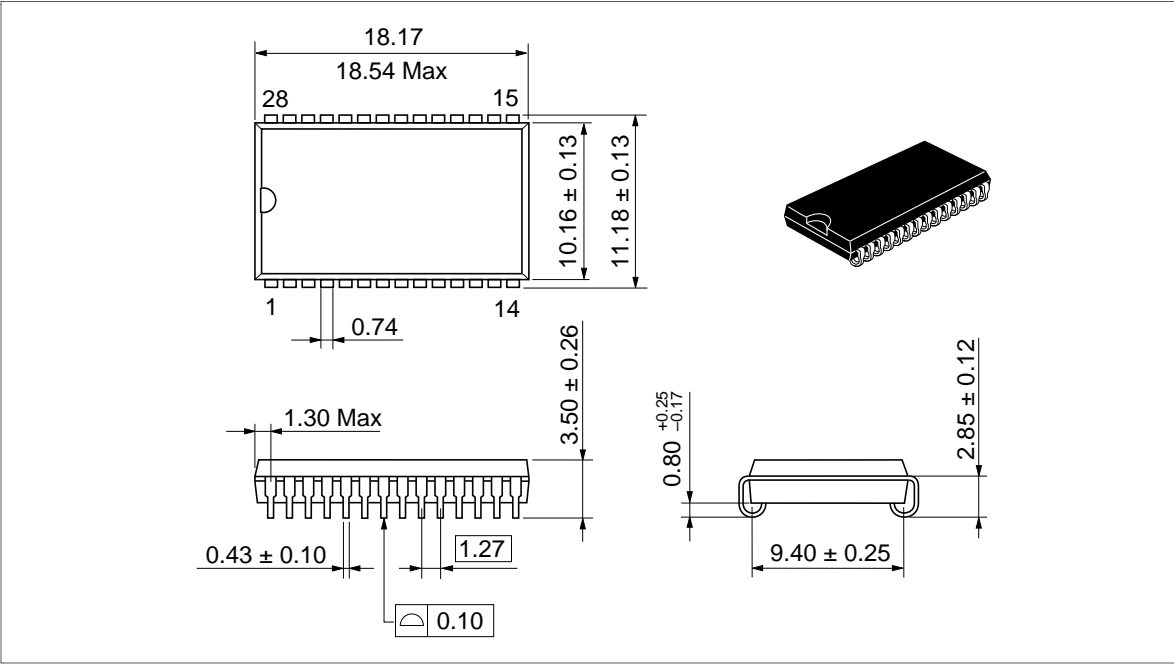

HM5117800BS/BLS Series (CP-28DNA)

Unit: mm

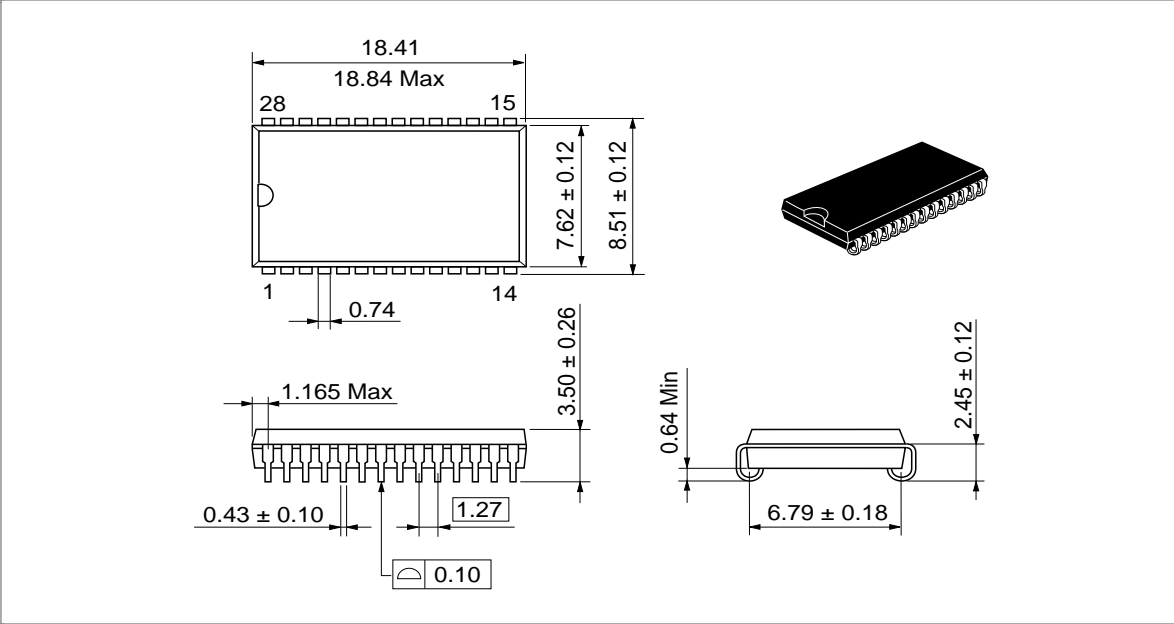

HM5117800B Series

Package Dimensions (cont)

HM5117800BTT/BLTT Series (TTP-28DA)

Unit: mm

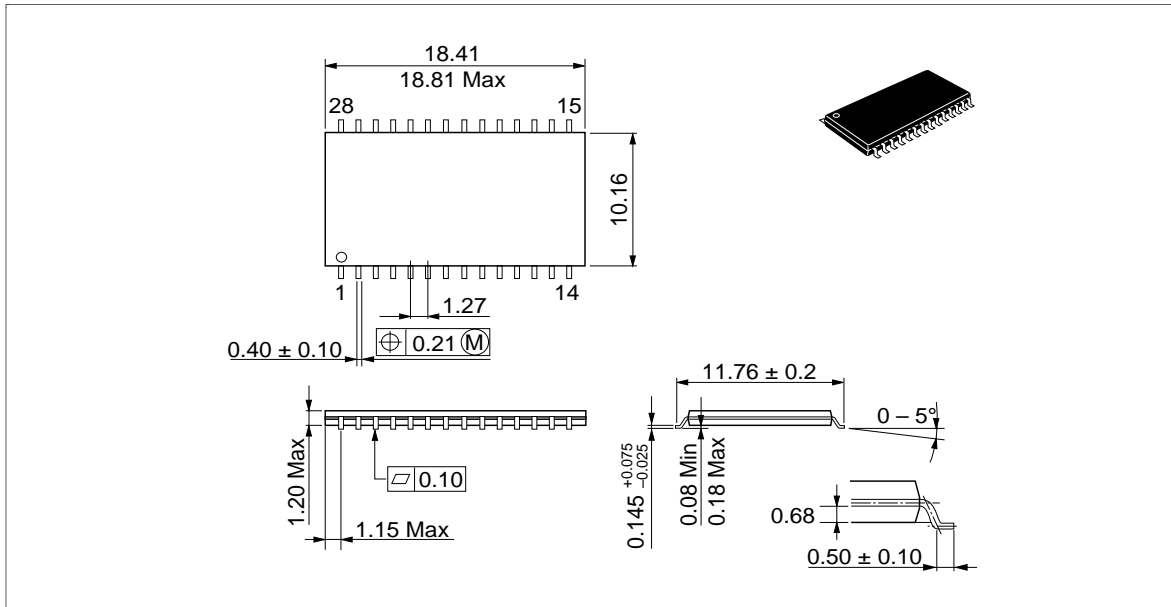

HM5117800BTS/BLTS Series (TTP-28DB)

Unit: mm

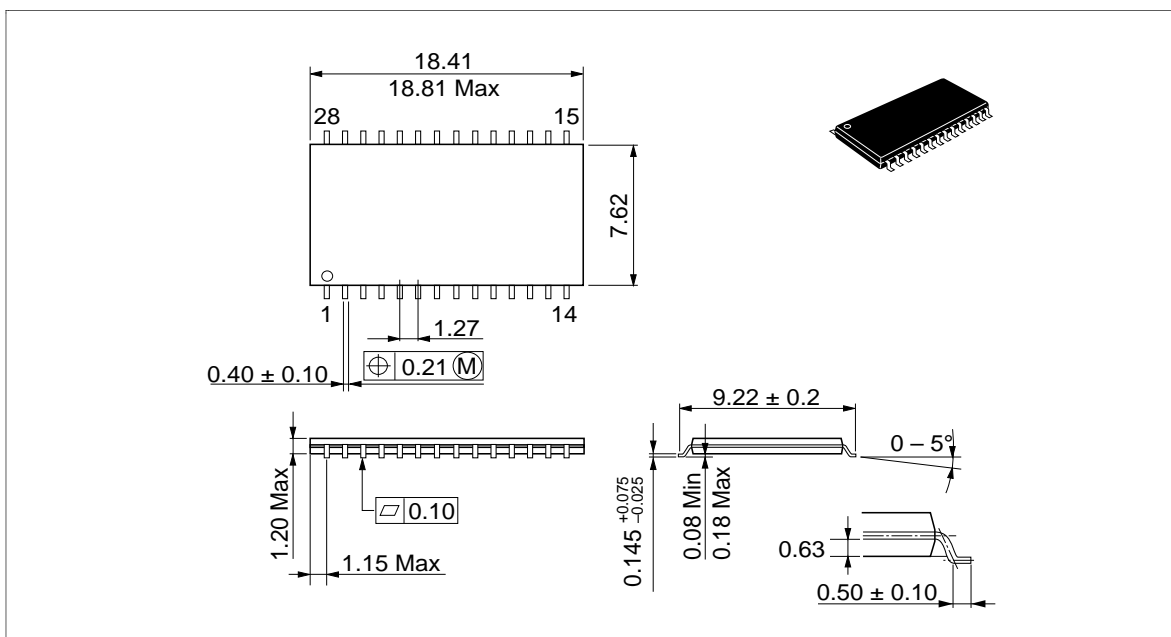

When using this document, keep the following in mind:

1. This document may, wholly or partially, be subject to change without notice.
2. All rights are reserved: No one is permitted to reproduce or duplicate, in any form, the whole or part of this document without Hitachi's permission.
3. Hitachi will not be held responsible for any damage to the user that may result from accidents or any other reasons during operation of the user's unit according to this document.
4. Circuitry and other examples described herein are meant merely to indicate the characteristics and performance of Hitachi's semiconductor products. Hitachi assumes no responsibility for any intellectual property claims or other problems that may result from applications based on the examples described herein.
5. No license is granted by implication or otherwise under any patents or other rights of any third party or Hitachi, Ltd.
6. **MEDICAL APPLICATIONS:** Hitachi's products are not authorized for use in **MEDICAL APPLICATIONS** without the written consent of the appropriate officer of Hitachi's sales company. Such use includes, but is not limited to, use in life support systems. Buyers of Hitachi's products are requested to notify the relevant Hitachi sales offices when planning to use the products in **MEDICAL APPLICATIONS**.

HITACHI

Hitachi, Ltd.

Semiconductor & IC Div.
Nippon Bldg., 2-6-2, Ohte-machi, Chiyoda-ku, Tokyo 100, Japan
Tel: Tokyo (03) 3270-2111
Fax: (03) 3270-5109

For further information write to:

Hitachi America, Ltd.
Semiconductor & IC Div.
2000 Sierra Point Parkway
Brisbane, CA. 94005-1835
U S A
Tel: 415-589-8300
Fax: 415-583-4207

Hitachi Europe GmbH
Electronic Components Group
Continental Europe
Dornacher Straße 3
D-85622 Feldkirchen
München
Tel: 089-9 91 80-0
Fax: 089-9 29 30 00

Hitachi Europe Ltd.
Electronic Components Div.
Northern Europe Headquarters
Whitebrook Park
Lower Cookham Road
Maidenhead
Berkshire SL6 8YA
United Kingdom
Tel: 0628-585000
Fax: 0628-778322

Hitachi Asia Pte. Ltd.
16 Collyer Quay #20-00
Hitachi Tower
Singapore 0104
Tel: 535-2100
Fax: 535-1533

Hitachi Asia (Hong Kong) Ltd.
Unit 706, North Tower,
World Finance Centre,
Harbour City, Canton Road
Tsim Sha Tsui, Kowloon
Hong Kong
Tel: 27359218
Fax: 27306071

HM5117800B Series

Revision Record

Rev.	Date	Contents of Modification	Drawn by	Approved by
0.0	Jun. 13, 1994	Initial issue	Y. Takahashi	K. Hayakawa
0.1	Nov. 11, 1994	Recommended DC Operating Conditions V_{IH} max: 6.5 V to $V_{CC} + 0.5$ V DC characteristics I_{CC7} max: 90/80/75 mA to 100/90/85 mA I_{LI} test conditions: $0 \text{ V} \leq V_{in} \leq 7 \text{ V}$ to $0 \text{ V} \leq V_{in} \leq V_{CC} + 0.5 \text{ V}$ I_{LO} test conditions: $0 \text{ V} \leq V_{out} \leq 7 \text{ V}$ to $0 \text{ V} \leq V_{out} \leq V_{CC} + 0.5 \text{ V}$ Addition of note 4	Y. Takahashi	K. Hayakawa
0.2	Dec. 2, 1994	Change of Block Diagram Recommended DC Operating Conditions V_{IH} max: $V_{CC} + 0.5$ V to 6.0 V DC characteristics I_{LI} test conditions: $0 \text{ V} \leq V_{in} \leq V_{CC} + 0.5 \text{ V}$ to $0 \text{ V} \leq V_{in} \leq 6 \text{ V}$ I_{LO} test conditions: $0 \text{ V} \leq V_{out} \leq V_{CC} + 0.5 \text{ V}$ to $0 \text{ V} \leq V_{out} \leq 6 \text{ V}$	Y. Takahashi	K. Hayakawa
2.0	Jul. 5, 1996	Addition of HM5117800BTS/BLTS Series (TTP-28DB) Addition of HM5117800BS/BLS Series (CP-28DNA) Recommended DC Operating Conditions V_{IH} max: 6.0 V to 6.5 V DC characteristics I_{LI} test conditions: $0 \text{ V} \leq V_{in} \leq 6 \text{ V}$ to $0 \text{ V} \leq V_{in} \leq 7 \text{ V}$ I_{LO} test conditions: $0 \text{ V} \leq V_{out} \leq 6 \text{ V}$ to $0 \text{ V} \leq V_{out} \leq 7 \text{ V}$ AC characteristics Change of notes 18 and 23 Timing waveforms Change of early write cycle and EDO page mode early write cycle Deletion of note: $t_{OE H} \geq t_{CWE}$		
