



深圳市拓丰源电子科技有限公司

TOPFOISON INDUSTRY Co., LIMITED

LCM Specification

产品说明书

Project No. 项目型号	TF24013B-QDIT-V0		
Customer 客户名称			
Module No. 客户型号			
Product type 产品内容	Standard LCD Module		
	240 x 3RGB x320 Dots		
	2.4" TFT LCD		
Signature by customer: 客户确认签章:			
Structure size: 结构尺寸:	<input type="checkbox"/> OK _____	备注:	
	<input type="checkbox"/> NG _____		
Electric property: 电气性能:	<input type="checkbox"/> OK _____	备注:	
	<input type="checkbox"/> NG _____		
	Designed by 设计	Checked by 审核	Approved by 批准
Signature 签名	Liu xiao qiang 刘晓强	Fang tian peng 范天鹏	Liu zhi sheng 刘智声
Rev. 版本	Date 日期	Description 更改内容	
V0	2013-03-01	Preliminary Specification Release	





--CONTENTS--

内容

	Page
1. General Description..... 基本描述	1-24
2. General Features..... 基本特	1-24
3. Block Diagram..... 控制示意图	1-24
4. LCM Structure chart..... 结构图	2-24
5. Pin Description..... 引脚定义	3-24
5. Absolute Maximum Ratings..... 最大值范围	4-24
6. Electrical Specification..... 电气特性	4-24
7. Optical Specification..... 光学特性	5-24
8. Timing Characteristics..... 时序特性	6-24
9. Touch Screen Panel Specifications..... 触摸屏规格	7-24
10. LCM Initial code..... 模组初始代码	9-24
11. Reliability and inspection standard..... 可靠性及检验标准	10-24
12. LCM Inspection standard..... 液晶模块质量检查标准	12-24
13. Precautions for using LCD modules..... 使用注意事项	17-24
14. Prior consult matter..... 提前商议事项	22-24
15. Outline dimension..... 外形尺寸	22-24
16. Packing..... 包装	23-24
17. Technical support	24-24





1. General Description 基本描述

- The TF24013B-QDIT model is a color TFT LCM and touch panel. This module has a 2.4 inch diagonally measured active area with QVGA(240 horizontal by 320 vertical pixel array).Each pixel is divided into red、green、 blue dots which are arranged in vertical stripe .

TF24013B-QDIT 是带电阻 TP 的 TFT 模组，该屏的尺寸为 2.4 英寸，分辨率是 QVGA (240X320 像素)，每个像素由红绿蓝三基色组成。

2. General Feature 基本特征

Item 项目	General feature 基本特征	Remark 备注
Display Mode 显示方式	Normally White. Transmissive LCD 常白，全透方式	
Viewing direction 视角方向	12 o'clock 12 点钟方向	
Driving method 驱动方式	a- si TFT active matrix a-si TFT 主动矩阵方式	
Input signals 接口方式	8 Bit compatible 8080 I/F 8 Bit 数据位 8080 系统	Used DB0-DB7
Outside dimensions 外形尺寸	42.72mm(W)×60.26mm(H)×3.65mm(D)(Typ)	
Active area 有效区域 (AA 区)	LCD: 36.72mm(W) ×48.96mm(H)	
	TP : 37.72(W) ×53.16mm(H)	
Number of Pixels 像素数	240(RGB) ×320 pixels	
Pixel Pitch 像素间距	0.153mm(W) ×0.153mm(H)	
Pixel Arrangement 像素排列	RGB vertical stripes RGB 竖条状	
Driver IC 驱动 IC	ILI9341	

3. Block Diagram 控制示意图

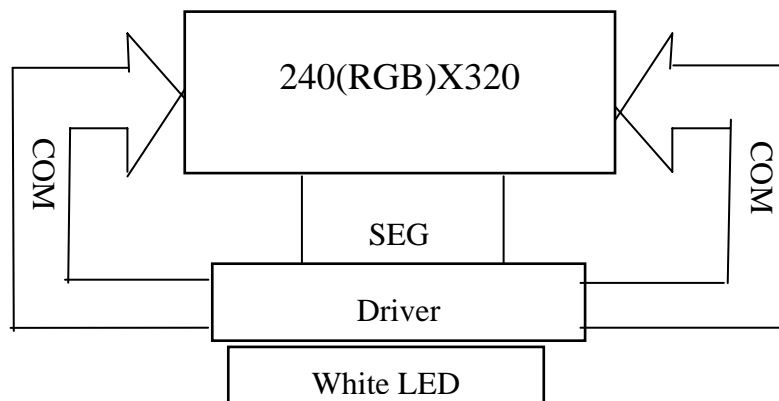



4.LCM Structure chart 结构图

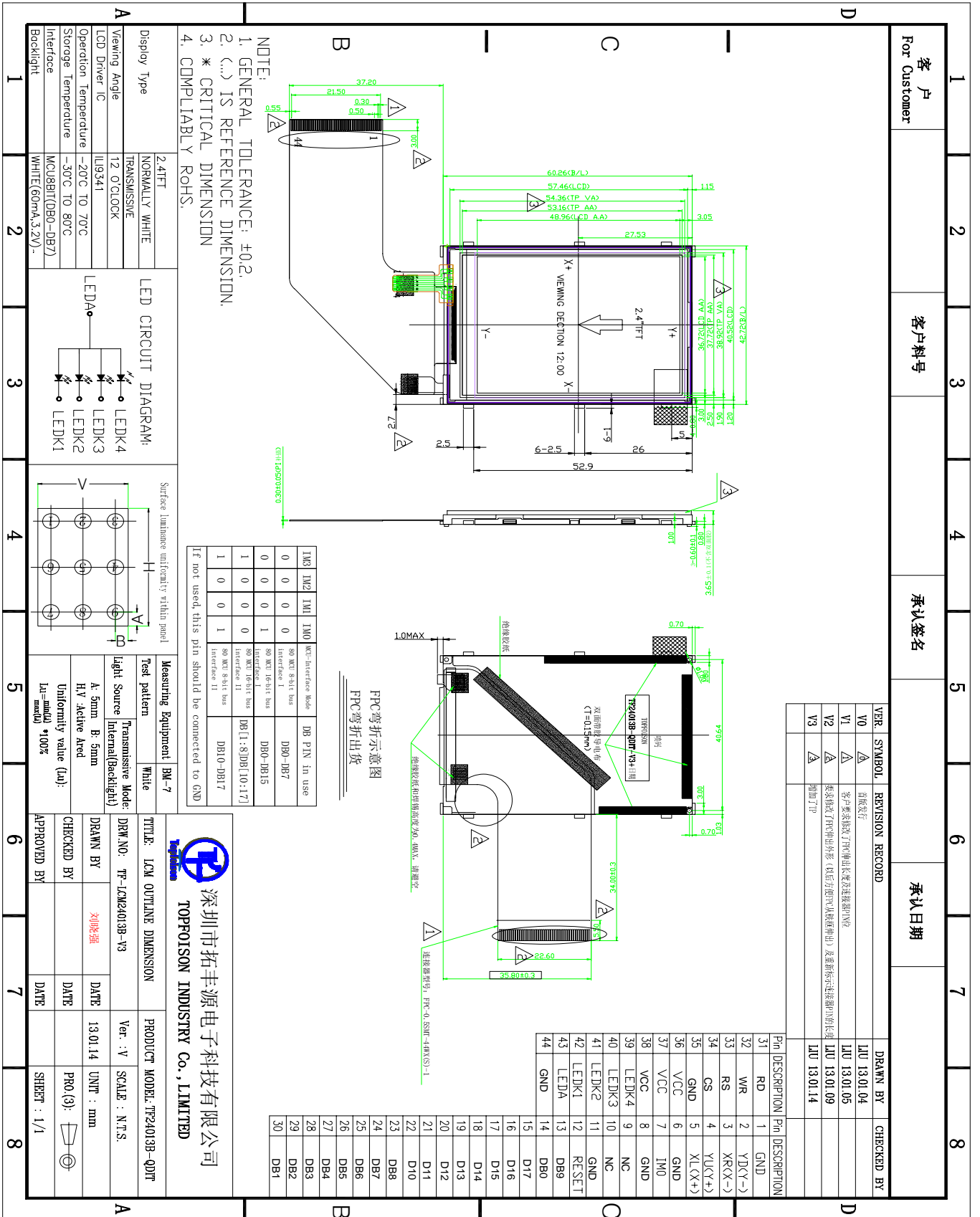



4. Pin Description 引脚定义

PIN NO.	PIN NAME	DESCRIPTION
1	GND	Ground pin
2	Y-(YD)	Touch panel interface
3	X+(XR)	Touch panel interface
4	Y+(YU)	Touch panel interface
5	X-(XL)	Touch panel interface
6	GND	Ground pin
7	IM0	NOTE1
8	GND	Ground pin
9 - 10	NC	Pin NC
11	GND	Ground pin
12	RESET	Reset signal: Active "L"
13	DB9	LCD data bus
14	DB0	LCD data bus
15-22	DB17-DB10	LCD data bus
23-30	DB8-DB1	LCD data bus
31	RD	LCM read signal: Active "L"
32	WR	LCM write signal: Active "L"
33	RS	LCD register selector
34	CS	Chip selection input pin: Active "L"
35	GND	Ground pin
36	VCC	Power supply for system 2.8V
37	VCC	Power supply for system 2.8V
38	VCC	Power supply for system 2.8V
39	LED-4	Backlight negative input pin
40	LED-3	Backlight negative input pin
41	LED-2	Backlight negative input pin
42	LED-1	Backlight negative input pin
43	LED-A	Backlight positive input pin
44	GND	Ground pin

NOTE1:

IM3	IM2	IM1	IM0	MCU-Interface Mode	DB PIN in use
0	0	0	0	80 MCU 8-bit bus interface I	DB0-DB7
0	0	0	1	80 MCU 16-bit bus interface I	DB0-DB15
1	0	0	0	80 MCU 16-bit bus interface II	DB[1:8]DB[10:17]
1	0	0	1	80 MCU 8-bit bus interface II	DB10-DB17

If not used, this pin should be connected to GND



5. Absolute Maximum Ratings 最大值范围

Ta=25±5°C, GND=0

Item 项目	Symbol 符号	Ratings 范围	Unit 单位	Condition 条件
Operating power 工作电压	V _{dd}	-0.3~4.6	V	
Operating temperature 工作温度	T _{OPR}	-20~70	°C	No condensation 不冷凝
Storage temperature 存储温度	T _{STR}	-30~80		

6. Electrical Specification 电气特性

6.1 DC characteristics 直流特性

GND =0V, V_{dd}=2.85±0.05V, T_{OPR} =-20~70°C

Item 项目	Symbol 符号	Condition 条件	Min. 最小值	Typ. 典型值	Max. 最大值	Unit 单位
Supply power 工作电压	V _{dd}		2.5	2.8	3.3	V
Input high voltage 输入高电平电压	V _{IH}		0.8V _{dd}	—	V _{dd}	
Input low voltage 输入低电平电压	V _{IL}		-0.3	—	0.2V _{dd}	
Output high voltage 输出高电平电压	V _{OH}		0.8V _{dd}	—	—	
Output low voltage 输出低电平电压	V _{OL}		—	—	0.2V _{dd}	
Logic current consumption 电流	I _{dd}		—	6.5	10	mA

6.2 Back light circuit characteristics (4 LEDS parallel): 背光驱动电路特性 (4 LEDS 并联)

Item 项目	Symbol 符号	Min 最小值	Typ. 典型值	Max. 最大值	Unit 单位	Condition 条件
Operating voltage 工作电压	V _{LED}	—	3.2	—	V	Each LED =15mA
Operating current 工作电流	I _{LED}	—	60	—	mA	Each LED =15mA
LCM luminance (display white) 模组亮度 (全白显示)	B	200	240	—	cd/m ²	—
BL luminance (display white) 背光亮亮度 (全白显示)	BL	4000	—	—	cd/m ²	—
LCM brightness uniformity (display white) 背光均匀度 (全白显示)	BU	80	—	—	%	—

Test condetion:LED*2+1 测试条件：亮色度试验:(灯*2+1)测试

7. Optical Specification 光学特性

7.1 LCD optical characteristics LCD 光学特性 $T_a=25^\circ\text{C}$

Item	Symbol	Condition	Min.	Typ.	Max.	Unit	Note
Transmittance (without Polarizer)	T(%)	—	—	(14.4)	—	—	
Contrast Ratio	CR	$\theta=0$	400	500	—	—	(1)(2)
Response time	Rising	T_R	—	4	8	msec	(1)(3)
	Falling	T_F	—	12	24		
Color gamut	S(%)			60		%	
Color chromaticity (CIE1931)	White	W_x	0.283	0.303	0.323	(1)(4) CF glass (C-light)	
		W_y	0.305	0.325	0.345		
	Red	R_x	0.606	0.626	0.646		
		R_y	0.314	0.334	0.354		
	Green	G_x	0.257	0.277	0.297		
		G_y	0.529	0.549	0.569		
Blue	B_x	0.122	0.142	0.162			
	B_y	0.102	0.122	0.142			
Viewing angle	Hor.	θ_L	CR>10	35	45	—	
		θ_R		35	45	—	
	Ver.	θ_U		35	45	—	
		θ_D		10	20	—	
Optima View Direction	12 O'clock						(5)

7.2 Measurement system 测量系统

(1) LCD Viewing Angle LCD 视角

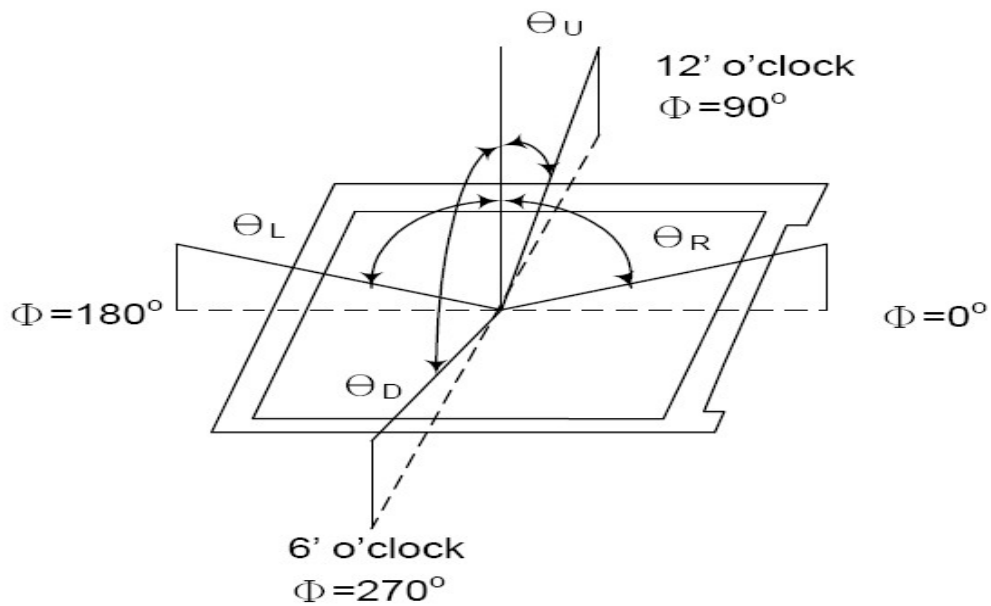

- Viewing angle is the angle at which the contrast ratio is greater than 10. The angles are determined for the horizontal or x axis and the vertical or y axis with respect to the z axis which is normal to the LCD surface.
视角是当对比度大于某一可接受值时，观察方向与液晶显示器件屏面法线之间的夹角。如图所示 水平视角为左右视角之和($\theta - +\theta +$)；垂视角为上下视角之和($\Phi - +\Phi +$)

(2) Response time 响应时间

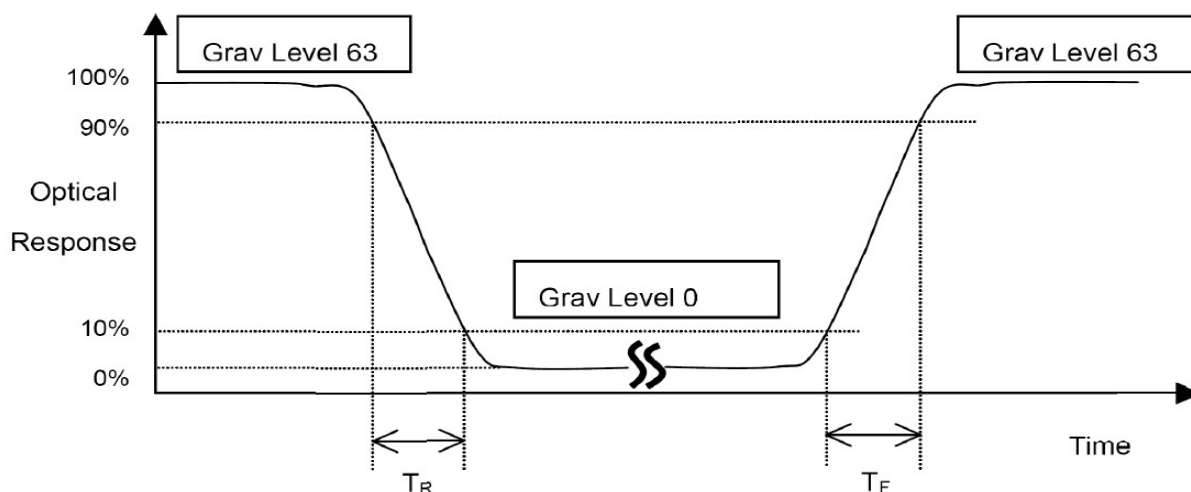

- Response time is the time required for the display to transition from white to black (Rising time, T_r) and from black to white (Falling time, T_f).for additional information
响应时间是在阶跃响应中，输出信号达到稳定值的特定范围的时间，包括上升时间和下降时间。

(3) Contrast Ratio(CR) 对比度

Contrast Ratio(CR) is defined mathematically as: CR 公式定义

$$\text{Contrast Ratio} = \frac{\text{Surface Luminance with all white pixels}}{\text{Surface Luminance with all black pixels}}$$

对比度 (CR) = $L_{\text{亮}} / L_{\text{暗}}$

式中： $L_{\text{亮}}$ — 产品在选态下的亮度；

$L_{\text{暗}}$ — 产品在非选态下的亮度。

- Surface luminance is the center point across the lcd surface 500mm from the surface with all pixels displaying white.
表面亮度是显示白色画面时测试的亮度值。

8. Timing Characteristics 时序特性

Refer to IC datasheet.



9.Touch Screen Panel Specifications 触摸屏规格

1	2	3	4	5	6	7	8																											
客户 For Customer			客户料号		承认签名		承认日期																											
注:1.银浆线不能进入VVA区内 2.双面胶不能溢胶进入VVA区内			正面		反面		<table border="1" style="width:100%; border-collapse: collapse;"> <thead> <tr> <th>VER.</th> <th>SYMBOL.</th> <th>REVISION RECORD</th> <th>DRAWN BY</th> <th>CHECKED BY</th> </tr> </thead> <tbody> <tr> <td>V0</td> <td>△</td> <td>首次发行</td> <td>LIU 13.01.14</td> <td></td> </tr> <tr> <td> </td> <td> </td> <td> </td> <td> </td> <td> </td> </tr> <tr> <td> </td> <td> </td> <td> </td> <td> </td> <td> </td> </tr> </tbody> </table>		VER.	SYMBOL.	REVISION RECORD	DRAWN BY	CHECKED BY	V0	△	首次发行	LIU 13.01.14																	
VER.	SYMBOL.	REVISION RECORD	DRAWN BY	CHECKED BY																														
V0	△	首次发行	LIU 13.01.14																															
<p>技术参数:</p> <ol style="list-style-type: none"> 1. 结构: ITO膜+ITO玻璃+FPC引线 2. 电路等级: DC≤5V 3. 绝缘电阻: ≥20MΩ(25V DC) 4. 透光率: ≥80% 5. 操作压力: <100g 6. 响应时间: <15ms 7. 触点电阻: X: 100~4000 Ω; Y: 300~5000 Ω 8. 表面硬度: 3H 9. 工作环境: -20℃~+70℃, ≤90%RH 10. 储存环境: -30℃~+80℃, ≤90%RH 					<table border="1" style="width:100%; border-collapse: collapse;"> <thead> <tr> <th colspan="2">逻辑走线表</th> </tr> </thead> <tbody> <tr> <td style="text-align: center;">1</td> <td style="text-align: center;">Y+</td> </tr> <tr> <td style="text-align: center;">2</td> <td style="text-align: center;">X+</td> </tr> <tr> <td style="text-align: center;">3</td> <td style="text-align: center;">Y-</td> </tr> <tr> <td style="text-align: center;">4</td> <td style="text-align: center;">X-</td> </tr> </tbody> </table>		逻辑走线表		1	Y+	2	X+	3	Y-	4	X-			<p style="text-align: center;">深圳市拓丰源电子科技有限公司 TOPFOISON INDUSTRY Co., LIMITED</p> <table border="1" style="width:100%; border-collapse: collapse;"> <tr> <td>TITLE: TP OUTLINE DIMENSION</td> <td>PRODUCT MODEL: TP24013B-QDIT</td> </tr> <tr> <td>DRW. NO: TP-TP24013B-V0</td> <td>Ver.: V</td> </tr> <tr> <td>DRAWN BY: 刘晓强</td> <td>SCALE: N.T.S.</td> </tr> <tr> <td>CHECKED BY:</td> <td>DATE: 13.01.14</td> </tr> <tr> <td>APPROVED BY:</td> <td>UNIT: mm</td> </tr> <tr> <td></td> <td>PROJ (3):</td> </tr> <tr> <td></td> <td>SHEET: 1/1</td> </tr> </table>		TITLE: TP OUTLINE DIMENSION	PRODUCT MODEL: TP24013B-QDIT	DRW. NO: TP-TP24013B-V0	Ver.: V	DRAWN BY: 刘晓强	SCALE: N.T.S.	CHECKED BY:	DATE: 13.01.14	APPROVED BY:	UNIT: mm		PROJ (3):		SHEET: 1/1
逻辑走线表																																		
1	Y+																																	
2	X+																																	
3	Y-																																	
4	X-																																	
TITLE: TP OUTLINE DIMENSION	PRODUCT MODEL: TP24013B-QDIT																																	
DRW. NO: TP-TP24013B-V0	Ver.: V																																	
DRAWN BY: 刘晓强	SCALE: N.T.S.																																	
CHECKED BY:	DATE: 13.01.14																																	
APPROVED BY:	UNIT: mm																																	
	PROJ (3):																																	
	SHEET: 1/1																																	





10. LCM Initial code 模组初始代码

Initial_ILI9341	
Page 1	Page 2
<pre>// VCI=2.8V //***** Reset CD Driver *****// LCD_nRESET = 1; delayms(1); // Delay 1ms LCD_nRESET = 0; delayms(10); // Delay 10ms // This delay time is necessary LCD_nRESET = 1; delayms(120); // Delay 120 ms //***** Start Initial Sequence *****// WMLCDCOM(0xCF); WMLCDDATA(0x00); WMLCDDATA(0xC1); WMLCDDATA(0x30); WMLCDCOM(0xED); WMLCDDATA(0x64); WMLCDDATA(0x03); WMLCDDATA(0x12); WMLCDDATA(0x81); WMLCDCOM(0xE8); WMLCDDATA(0x85); WMLCDDATA(0x10); WMLCDDATA(0x7A); WMLCDCOM(0xCB); WMLCDDATA(0x39); WMLCDDATA(0x2C); WMLCDDATA(0x00); WMLCDDATA(0x34); WMLCDDATA(0x02); WMLCDCOM(0xF7); WMLCDDATA(0x20); WMLCDCOM(0xEA); WMLCDDATA(0x00); WMLCDDATA(0x00); WMLCDCOM(0xC0); //Power control WMLCDDATA(0x23); //VRH[5:0] WMLCDCOM(0xC1); //Power control WMLCDDATA(0x12); //SAP[2:0];BT[3:0] WMLCDCOM(0xC5); //VCM control WMLCDDATA(0x60); //68 WMLCDDATA(0x44); WMLCDCOM(0xC7); //VCM control2 WMLCDDATA(0x8A); WMLCDCOM(0x36); // Memory Access Control WMLCDDATA(0x08); WMLCDCOM(0x3A); WMLCDDATA(0x55); WMLCDCOM(0xB1); WMLCDDATA(0x00); WMLCDDATA(0x18); WMLCDCOM(0xB6); // Display Function Control WMLCDDATA(0x0A); WMLCDDATA(0xA2); WMLCDCOM(0xF6); WMLCDDATA(0x01); WMLCDDATA(0x30);</pre>	<pre>WMLCDCOM(0xF2); // 3Gamma Function Disable WMLCDDATA(0x00); WMLCDCOM(0x26); //Gamma curve selected WMLCDDATA(0x01); WMLCDCOM(0xE0); //Set Gamma WMLCDDATA(0x0F); WMLCDDATA(0x2F); WMLCDDATA(0x2C); WMLCDDATA(0x0B); WMLCDDATA(0x0F); WMLCDDATA(0x09); WMLCDDATA(0x56); WMLCDDATA(0xD9); WMLCDDATA(0x4A); WMLCDDATA(0x0B); WMLCDDATA(0x14); WMLCDDATA(0x05); WMLCDDATA(0x0C); WMLCDDATA(0x06); WMLCDDATA(0x00); WMLCDCOM(0xE1); //Set Gamma WMLCDDATA(0x00); WMLCDDATA(0x10); WMLCDDATA(0x13); WMLCDDATA(0x04); WMLCDDATA(0x10); WMLCDDATA(0x06); WMLCDDATA(0x25); WMLCDDATA(0x26); WMLCDDATA(0x3B); WMLCDDATA(0x04); WMLCDDATA(0x0B); WMLCDDATA(0x0A); WMLCDDATA(0x33); WMLCDDATA(0x39); WMLCDDATA(0x0F); WMLCDCOM(0x11); //Exit Sleep Delayms(120); WMLCDCOM(0x29); //Display on WMLCDCOM(0x2c); } void MainLCD_GRAMWrite_Set(void) { WMLCDCOM(0x2C); //send DDRAM set } void LCD_Enter Sleep_ILI9341(void) { WMLCDCOM(0x28); // Display off Delayms(20); WMLCDCOM(0x10); // Enter Sleep mode } void LCD_Exit Sleep_ILI9341(void) { WMLCDCOM(0x11); // Sleep out Delayms(120); WMLCDCOM(0x29); // Display on } }</pre>



11 . Reliability and inspection standard 可靠性及检验标准

11.1 Environment test (reliability test) 环境试验 (可靠性试验)

Samples OK before testing 样品试验前 ok

Test item 测试项目	Test condition 测试条件
High temperature storage 高温存储	80℃ , 48hr
Low temperature storage 低温存储	-30℃ , 240 hr/ -40℃ , 8hr
High temperature operation 高温操作	70℃ , 48 hr
Low temperature operation 低温操作	-20℃ , 48 hr
High temperature and high humidity operation 高温高湿操作	60℃、95%RH , 48 hr
Thermal shock 冷热冲击	-40℃ (30min) → 80℃ (30min) 48 cycles

After completing the reliability test, leave the samples under the room temperature and for the following inspection items:

可靠性测试完成后，在室温存放 4 小时，再按以下步骤检测

- ① No clearly visible defects or deterioration of display quality allowed.
无明显的质量及外观上的不合格。
- ② No function-related abnormalities.
应无任何功能异常。
- ③ Connected parts still connecting tightly.
外观的接合部分依然紧密连接
- ④ Display characteristics fulfill initial value , contrast ratio should be an least 30% of initial value.
显示特性满足初期的规格，对比度不低于最初对比度的 30%。

11.2 Ultraviolet radiation irradiation test 紫外线照射测试

After Samples irradiated by ultraviolet tradition, have no deterioration of display quality
紫外线照射后，显示功能应正常



11.3 Mechanical test 产品的机械特性试验

1) Vibration test 振动试验

Test item 测试项目	Test content 测试条件	
In mobile telephone 装入手机中	Reference mobile phone test standard 参考手机测试标准	
Vibration test (packed) 振动测试 (包装)	frequency / acceleration 频率/加速度	30Hz/2.5m/s ²
	Direction 方向	X、Y、Z 3 direction X、Y、Z 3 个方向
	Time 时间	30min respectively 各 30 分钟

After completing the vibration tests, the samples have No function-related abnormalities or structure distortion.

经过振动测试应无结构变形及显示功能异常现象。

2) Shock test 冲击测试 (包装状态)

Peak acceleration 峰值加速度 m/s ²	Pulse holding time 脉冲持续时间	Shock wave 冲击波形
300	11ms	Half sine wave or back peak sawtooth wave or trapeziform wave 半正弦波 或后峰锯齿波 或梯形波

After completing the shock tests, the samples have No function-related abnormalities or structure distortion .

经过振动测试应无结构变形及显示功能异常现象。

3) Packing part drop test (包装件跌落测试)

Test item 测试项目	Test content 测试内容	
drop (packed in a box) 跌落 (包装状态)	Height 高度	80cm
	Drop mode 跌落方式	Freedom drop 自由落体
	Drop part 跌落部位	1 corner/3 arris/6 face, 1time respectively 一角三棱六个面各一次

After completing the packing part drop tests, the samples have no function-related abnormalities or structure distortion.

经过跌落测试应无结构变形及显示功能异常现象

11.4 Electron magnetic compatibility 电磁兼容性测试

Electrostatic withstanding voltage 静电放电 (配合整机测试)

After air contact discharge (voltage: $\pm 8\text{KV}$) and contact discharge directly (voltage: $\pm 4\text{KV}$) test, the samples display ok, and have no flicker, white screen, black screen, blue screen etc. abnormality display.

经过空气接触放电 (在产品结构存在的缝隙处完全放电, 电压: $\pm 8\text{KV}$) 和直接接触放电 (接触金属外露部分放电, 电压: $\pm 4\text{KV}$) 测试, 产品应无“花屏 (乱码)、闪屏 (显示不稳定)、白屏 (死机或无显示)、黑屏 (死机或无显示)、蓝屏 (死机或无显示)”等异常现象。

12. LCM Inspection standard 液晶模块质量检查标准

1. Purpose 目的

To confirm LCM module shipment quality inspection standards, methods and acceptance criteria in order to control the quality to meet production and customer requirements

明确 LCM 模块出货质量检查标准及检查方法与可接受标准, 以更好的控制成出货品质, 满足生产和顾客的要求。

2. Scope 适用范围

All LCM module

适用于 LCM 模块产品。

3. Sampling plan and defect definition 抽样方案及缺陷定义

- Using standard GB / T 2828.1-2003, it's a general inspection method of LEVEL II. If the customer has specific requirements, give priority of sampling plan to customer.
- Major defect: the defects of some or all the function
- Minor defect: There is some defects, but it doesn't lead to function defects.
- Major defect: AQL 0.65 Minor defect: AQL 1.5

采用标准 GB/T 2828.1-2003, 一般检验的 II LEVEL 的检验方式。如客户有具体要求, 优先使用客户提供抽样方案。

主要缺陷: 将使产品部分或全部丧失功能的缺陷。

次要缺陷: 有缺陷, 但不导致功能不良或丧失。

主要缺陷: AQL 0.65 次要缺陷: AQL 1.5

4. Inspection condition and appearance definition 检查条件及外观区域定义

4.1 Inspection condition 检查条件

Under the daylight lamp (about 60 cm & brightness is about 1000~2000 Lux), a distance from the inspector's eyes is about $25 \pm 5\text{cm}$, and the eyes gaze is between 45 degrees of the LCD vertical direction and the viewing angle of angle. About 12s.

在日光灯 (上方约 60cm) 的光照环境下 (光亮度为 1000~2000 Lux), 样品离检查者眼睛的距离约为 $25 \pm 5\text{cm}$, 眼睛视线在 LCD 垂直方向和 LCD 视角方向的 45 度夹角之间。时间约 12 秒。

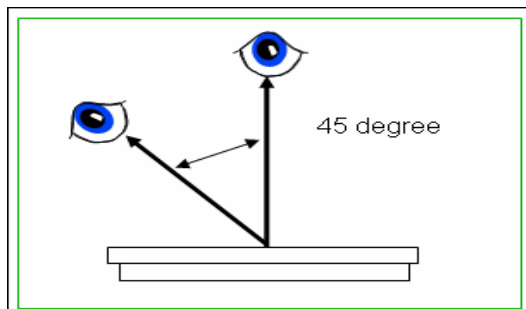

4.2 Appearance definition 外观区域定义

4.2.1 LCM 屏组件

- Area A: active areas, symbols and figures area
- Area B: VA area / visual area, (except area A) around the active area
- Area C: outside the visual area(where not to be seen after assembled)

Note: there is the appearance defect outside LCM module visual area, but it doesn't affect product assembly. It's acceptable.

区域 A: 有效区, 符号和数字显示区

区域 B: VA 区/视区 (虚线内, A 区外) (A 区+B 区=装机壳后可视区域, 具体尺寸参照 LCM 图纸上所标示的 VA 区)

区域 C: 可视区外围 (手机外壳装配后模块看不见区域)

注: LCM 模块视区外有看得见的外观缺陷, 不影响顾客产品组装, 可允许。

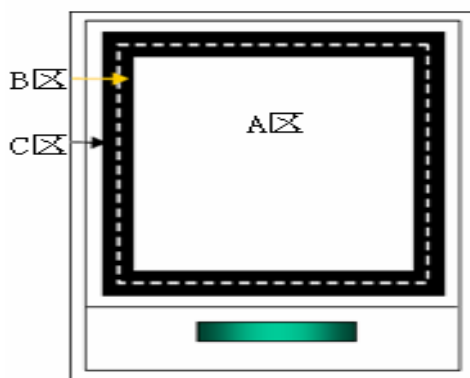

5.0 Inspection standard 检验标准

5.1 Major defect 主要缺陷

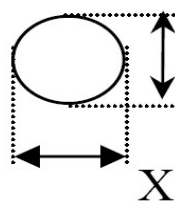
NO. 序号	Item 检验项目	Standard 检验标准	Judgment 判断	AQL
5.1.1	Function defect 功能缺陷	1) no display 不显示 2) shows abnormal 显示异常 3) lack line 缺线 4) the backlight does not work、flick 背光点不亮、闪烁	NG	0.65
5.1.2	Omit 遗漏	missing components that affect the product function 缺少元器件, 影响产品功能	NG	
	Black/white spot defect (in displaying)	black/white spot definition $\Phi = \frac{(x+y)}{2}$ 	y	



<p>5.1.3</p>	<p>黑/白点缺点 (在显示区内)</p>	<p>1. black/white spot defect (I)</p> <table border="1"> <thead> <tr> <th rowspan="2">area size (mm)</th> <th colspan="3">Acceptable number</th> </tr> <tr> <th>A</th> <th>B</th> <th>C</th> </tr> </thead> <tbody> <tr> <td>$\Phi \leq 0.1$</td> <td colspan="3">ignore</td> </tr> <tr> <td>$0.10 < \Phi \leq 0.15$</td> <td colspan="3">3</td> </tr> <tr> <td>$0.15 < \Phi \leq 0.25$</td> <td colspan="3">2</td> </tr> <tr> <td>$\Phi > 0.25$</td> <td colspan="3">0</td> </tr> </tbody> </table> <p>2. black/white spot defect (II)</p> <table border="1"> <thead> <tr> <th rowspan="2">area size (mm)</th> <th colspan="3">Acceptable number</th> </tr> <tr> <th>A</th> <th>B</th> <th>C</th> </tr> </thead> <tbody> <tr> <td>$\Phi \leq 0.3$</td> <td colspan="3">ignore</td> </tr> <tr> <td>$0.30 < \Phi \leq 0.50$</td> <td colspan="3">5 (spacebetween is 20mm)</td> </tr> <tr> <td>$0.50 < \Phi \leq 1.00$</td> <td colspan="3">3(spacebetween is 50mm)</td> </tr> <tr> <td>$1.00 < \Phi$</td> <td colspan="3">0</td> </tr> </tbody> </table>	area size (mm)	Acceptable number			A	B	C	$\Phi \leq 0.1$	ignore			$0.10 < \Phi \leq 0.15$	3			$0.15 < \Phi \leq 0.25$	2			$\Phi > 0.25$	0			area size (mm)	Acceptable number			A	B	C	$\Phi \leq 0.3$	ignore			$0.30 < \Phi \leq 0.50$	5 (spacebetween is 20mm)			$0.50 < \Phi \leq 1.00$	3(spacebetween is 50mm)			$1.00 < \Phi$	0			<p>Minor</p>																				
area size (mm)	Acceptable number																																																																				
	A	B	C																																																																		
$\Phi \leq 0.1$	ignore																																																																				
$0.10 < \Phi \leq 0.15$	3																																																																				
$0.15 < \Phi \leq 0.25$	2																																																																				
$\Phi > 0.25$	0																																																																				
area size (mm)	Acceptable number																																																																				
	A	B	C																																																																		
$\Phi \leq 0.3$	ignore																																																																				
$0.30 < \Phi \leq 0.50$	5 (spacebetween is 20mm)																																																																				
$0.50 < \Phi \leq 1.00$	3(spacebetween is 50mm)																																																																				
$1.00 < \Phi$	0																																																																				
<p>5.1.4</p>	<p>Black/white line defec (t in displaying) 黑/白线缺线 (在显示区内)</p>	<p>1. black/white line defect (I)</p> <table border="1"> <thead> <tr> <th colspan="2">size (mm)</th> <th colspan="3">Acceptable number</th> </tr> <tr> <th rowspan="2">L(length)</th> <th rowspan="2">W(width)</th> <th colspan="3">area</th> </tr> <tr> <th>A</th> <th>B</th> <th>C</th> </tr> </thead> <tbody> <tr> <td>$10 < L$</td> <td>$0.03 < W \leq 0.04$</td> <td colspan="3">5</td> </tr> <tr> <td>$5.0 < L \leq 10$</td> <td>$0.04 < W \leq 0.06$</td> <td colspan="3">3</td> </tr> <tr> <td>$1.0 < L \leq 5.0$</td> <td>$0.06 < W \leq 0.07$</td> <td colspan="3">2</td> </tr> <tr> <td>$L \leq 1.0$</td> <td>$0.07 < W \leq 0.09$</td> <td colspan="3">1</td> </tr> </tbody> </table> <p>2. black/white line defect(II)</p> <table border="1"> <thead> <tr> <th colspan="2">size(mm)</th> <th colspan="3">Acceptable number</th> </tr> <tr> <th rowspan="2">L(length)</th> <th rowspan="2">W(width)</th> <th colspan="3">area</th> </tr> <tr> <th>A</th> <th>B</th> <th>C</th> </tr> </thead> <tbody> <tr> <td>$20 < L$</td> <td>$0.05 < W \leq 0.07$</td> <td colspan="3">5</td> </tr> <tr> <td>$10 < L \leq 20$</td> <td>$0.07 < W \leq 0.09$</td> <td colspan="3">3</td> </tr> <tr> <td>$5.0 < L \leq 10$</td> <td>$0.09 < W \leq 0.10$</td> <td colspan="3">2</td> </tr> <tr> <td>$L \leq 5.0$</td> <td>$0.10 < W \leq 0.15$</td> <td colspan="3">1</td> </tr> </tbody> </table>	size (mm)		Acceptable number			L(length)	W(width)	area			A	B	C	$10 < L$	$0.03 < W \leq 0.04$	5			$5.0 < L \leq 10$	$0.04 < W \leq 0.06$	3			$1.0 < L \leq 5.0$	$0.06 < W \leq 0.07$	2			$L \leq 1.0$	$0.07 < W \leq 0.09$	1			size(mm)		Acceptable number			L(length)	W(width)	area			A	B	C	$20 < L$	$0.05 < W \leq 0.07$	5			$10 < L \leq 20$	$0.07 < W \leq 0.09$	3			$5.0 < L \leq 10$	$0.09 < W \leq 0.10$	2			$L \leq 5.0$	$0.10 < W \leq 0.15$	1			<p>Minor</p>
size (mm)		Acceptable number																																																																			
L(length)	W(width)	area																																																																			
		A	B	C																																																																	
$10 < L$	$0.03 < W \leq 0.04$	5																																																																			
$5.0 < L \leq 10$	$0.04 < W \leq 0.06$	3																																																																			
$1.0 < L \leq 5.0$	$0.06 < W \leq 0.07$	2																																																																			
$L \leq 1.0$	$0.07 < W \leq 0.09$	1																																																																			
size(mm)		Acceptable number																																																																			
L(length)	W(width)	area																																																																			
		A	B	C																																																																	
$20 < L$	$0.05 < W \leq 0.07$	5																																																																			
$10 < L \leq 20$	$0.07 < W \leq 0.09$	3																																																																			
$5.0 < L \leq 10$	$0.09 < W \leq 0.10$	2																																																																			
$L \leq 5.0$	$0.10 < W \leq 0.15$	1																																																																			
<p>5.1.4</p>	<p>Blemish & foreign matters</p>	<p>1. dot (LCD)</p> <table border="1"> <thead> <tr> <th rowspan="3">size(mm)</th> <th colspan="3">Acceptable number</th> </tr> <tr> <th colspan="3">area</th> </tr> <tr> <th>A</th> <th>B</th> <th>C</th> </tr> </thead> <tbody> <tr> <td>$\Phi \leq 0.1$</td> <td colspan="3">ignore</td> </tr> <tr> <td>$0.10 < \Phi \leq 0.15$</td> <td colspan="3">2</td> </tr> <tr> <td>$0.15 < \Phi \leq 0.25$</td> <td colspan="3">1</td> </tr> <tr> <td>$0.25 < \Phi$</td> <td colspan="3">0</td> </tr> </tbody> </table> <p>2. blemish (on touch panle or between touch panel ane LCD)</p>	size(mm)	Acceptable number			area			A	B	C	$\Phi \leq 0.1$	ignore			$0.10 < \Phi \leq 0.15$	2			$0.15 < \Phi \leq 0.25$	1			$0.25 < \Phi$	0			<p>Minor</p>																																								
size(mm)	Acceptable number																																																																				
	area																																																																				
	A	B	C																																																																		
$\Phi \leq 0.1$	ignore																																																																				
$0.10 < \Phi \leq 0.15$	2																																																																				
$0.15 < \Phi \leq 0.25$	1																																																																				
$0.25 < \Phi$	0																																																																				



size(mm)	Acceptable number		
	AREA		
	A	B	C
$\Phi \leq 0.1$	ignore		ignore
$0.10 < \Phi \leq 0.15$	1		
$0.15 < \Phi$	0		

3.line (LCD/touch panle)

size(mm)		Acceptable number			
L(length)	W(width)	area			
		A	B	C	
Ignore	$W \leq 0.02$	5			ignore
$L \leq 3.0$	$0.02 < W \leq 0.03$	3			
$L \leq 2.0$	$0.03 < W \leq 0.05$	2			
---	$W > 0.05$	Treat with dot			

Expect the above major defect, all the appearance defect is the minor defect.
除以上功能主要缺陷以外,所有的外观缺陷列为次要缺陷。

5.2 Minor defect 次要缺陷

5.2.1 White Color Coordinate inspection (Sampling before shipping)

亮度色度的检测要求:出货时要求进行抽查一定比例



5.2.2 FPC Gold finger FPC及金手指

- 1) FPC Gold finger defect is less than 1/2 and the number is less than 3
焊接类 FPC 金手指缺损小于 1/2 长度且数量少于 3 条时可接受.
- 2) No short circuit
焊接类 FPC 金手指上锡, 不出现连锡短路可接受
- 3) smear and function damaged
插接类 FPC 金手指上锡/擦拭不掉的污痕, 影响插接功能时不可接受

5.2.3 frame 铁框

Plane \leq 0.2 mm 平面度 平面度大于 0.20mm,不允许。

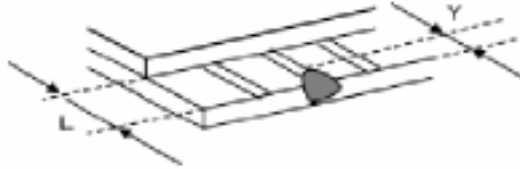
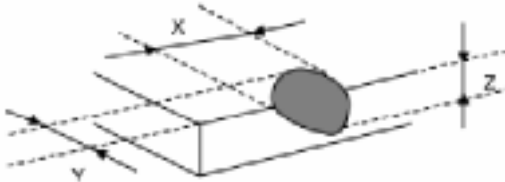
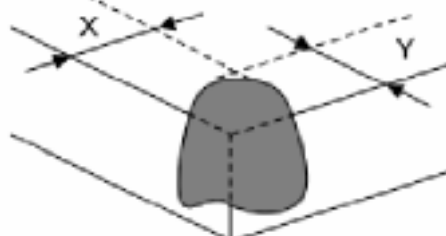
5.2.4 Glass defect 屏破标准

<p>(5-5-14)ガラス欠け Glass Voids</p>	<p>(1)ITO膜にかかる欠け Voids on ITO Membrane</p>  <p>$Y \leq (1/4) \times L$ $1.4 \leq (L - Y)$</p>
	<p>(2)一般欠け General Voids</p>  <p>$X \leq 5.0\text{mm}$ $Y \leq 1.0\text{mm}$ $Z \leq \text{不問}$</p> <p>但し、シール部・パターン・回路部に及ばないこととする。欠けが複数箇所ある場合については別途協議とする。 However, it must not extend to the seal area. When there are multiple voids, this must be discussed separately.</p> <p>Xはリヨウ線方向に対して幅方向 (X: width) Yはリヨウ線方向に対して奥方向 (Y: perpendicular to X) Zはリヨウ線方向に対して板厚方向 (Z: thickness)</p>
	<p>(3)コーナー部分欠け Void at Corner</p>  <p>$X \leq 1.5\text{mm}$ $Y \leq 1.5\text{mm}$ Z: 不問 Ignore</p> <p>但し、シール部・パターン・回路部に及ばないこととする。また、2カ所の場合は$Y \leq 1$とする。 However, it must not extend to the seal area. When there are 2 places, $Y \leq 1$</p>
	<p>(4)進行性のある欠け Progressive Cracks</p> <p>※4 Note 4</p>  <p>全て不良とする None are permitted</p>

5.2.2 display askew 显示歪

显示歪 >

PMC Confider

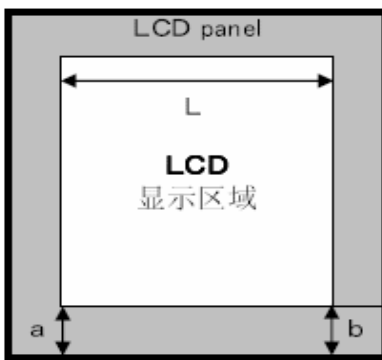

表示区域宽度:L	a—b
20.0mm以上	0.4mm以下
20.0mm以下	0.2mm以下

<注意事项>
但以下内容不可。

- ①. 显示的文字欠缺看不见。
- ②. 漏光看不见。
- ③. LCD接合端面正面看不到。

基准线为水平

5.2.3 light leak inspection 漏光查看标准

产品垂直状态(漏光处垂直)下、漏光处与目视检查者正面保持30cm、确认无漏光现象。

为了保证是从正面看，把漏光处作为支点，倾斜±3度时、确认无漏光现象。

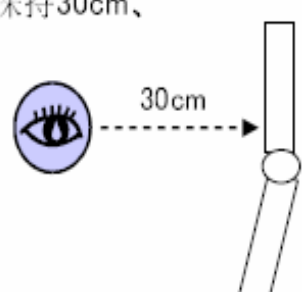

13. Precautions for using LCD modules 使用注意事项

13.1 Handling Precautions 处理注意事项

13.1.1 The display panel is made of glass and polarizer. As glass is fragile. It tends to be corner chipped during handling especially on the edges. Please avoid dropping or jarring. Do not subject it to a mechanical shock by dropping it or impact.

显示屏由玻璃和偏光片组成。由于玻璃是易碎的，使用过程中要特别注意边缘区。请防止跌落或振动。不能机械碰撞。

13.1.2 If the display panel is damaged and the liquid crystal substance leaks out, be sure not to get any in your mouth. If the substance contacts your skin or clothes, wash it off using soap and water.

如果显示屏损坏且液晶物质泄漏，切勿入口。如果液晶物质与皮肤或衣服接触，请使用肥皂和水冲洗。

13.1.3 Do not apply excessive force to the display surface or the adjoining areas since this may cause the color tone to vary. Do not touch the display with bare hands. This will stain the display area and degraded insulation between terminals (some cosmetics are determined to the polarizer).

请勿施加过大的压力于显示屏或连接部位，否则会引起色调变化。不要用手接触显示屏，这将弄脏显示区和降低端子之间的绝缘能力（一些外观是由偏光片决定的）。

13.1.4 The polarizer covering the display surface of the LCD module is soft and easily scratched. Handle this polarizer carefully. Do not touch, push or rub the exposed polarizer with anything harder than an HB pencil lead(glass, tweezers, etc.). Do not put or attach anything on the display area to avoid leaving marks on it.



Condensation on the surface and contact with terminals due to cold will damage, stain or dirty the polarizer. After products are tested at low temperature they must be warmed up in a container before coming in to contact with room temperature air.

覆盖液晶显示模块表面的偏光片是软性且易被擦伤，请小心对待。请勿用任何硬度大于 HB 铅笔芯的物品（玻璃，镊子等）接触、撞压或摩擦裸露偏光片。不要放置或粘附物体在显示区域上以免留下痕迹。由于冷而冷凝在表面和端子上的物质将会损坏或弄脏偏光片。产品在低温下测试之后，与室温空气接触之前必须在容器内升温。

13.1.5 If the display surface becomes contaminated, breathe on the surface and gently wipe it with a soft dry cloth. If it is heavily contaminated, moisten cloth with one of the following solvents

- Isopropyl alcohol
- Ethyl alcohol

Do not scrub hard to avoid damaging the display surface.

Do not scrub to use more solvents to avoid damaging the display BL.

如果显示平面受污，可对平面吹热气且轻轻地用软性干布擦除。如果受污严重，用含下列一种溶剂的湿布擦除：

- 异丙醇
- 酒精

请勿用力擦拭以免损坏显示平面。

请勿用大量溶剂，防止溶剂由于毛细现象渗入模块背光膜内造成污染

13.1.6 Solvents other than those above-mentioned may damage the polarizer. Especially, do not use the following.

- Water
- Ketone
- Aromatic solvents

Wipe off saliva or water drops immediately, contact with water over a long period of time may cause deformation or color fading. Avoid contact with oil and fats.

除以上提到的溶剂外，其他溶剂可能会损坏偏光片，特别要避免使用以下溶剂：

- 水
- 酮
- 芳烃溶剂

立即擦掉唾液或水滴，长时间与水接触会引起变形或褪色。避免接触油和油脂。

13.1.7 Especially care to minimize corrosion of the electrode. Corrosion of the electrodes is accelerated by water droplets, moisture condensation or a current flow in a high-humidity environment.

特别注意最小限度地减少电极腐蚀，水滴、水汽凝结或高湿环境下通电会加速。

13.1.8 Install the LCD Module by using the mounting holes. When mounting the LCD module make sure it is free of twisting, warping and distortion. In particular, do not forcibly pull or bend the IO cable or the backlight cable.

使用安装孔装配液晶显示模块，安装时一定要不要弯曲、扭曲和变形。要特别注意不要用力拔，弯曲传输线或背光线。

13.1.9 Do not attempt to disassemble or process the LCD module.

请勿拆卸液晶显示模块。

13.1.10 NC terminal should be open. Do not connect anything.

悬空端应断开，不要连接任何器件。

13.1.11 If the logic circuit power is off, do not apply the input signals.

如果逻辑电路电源是断开的，不要施加输入信号。

13.1.12 Electro-Static Discharge Control , Since this module uses a CMOS LSI, the same careful attention should be paid to electrostatic discharge as for an ordinary CMOS IC. To prevent destruction of the elements by static electricity, be careful to maintain an optimum work environment.

由于液晶显示模块使用 CMOS 集成，要特别注意静电放电问题。对 CMOS 器件，要特别注意静电。为防止静电损坏，注意保持合宜的工作环境。

- Before removing LCM from its packing case or incorporating it into a set, be sure the module and your body have the same electric potential. Be sure to ground the body when handling the LCD modules.

-液晶显示模块移出包装盒和安装之前，要保证模块和人体具有相同的电位。取放模块时，可靠接地。

- Tools required for assembling, such as soldering irons, must be properly grounded Make certain the AC power source for the soldering iron does not leak. When using an electric screwdriver to attach LCM, the



screwdriver should be of ground potentiality to minimize as much as possible any transmission of electromagnetic waves produced sparks coming from the commutator of the motor.

- 使用工具如电烙铁，要可靠接地，并确保烙铁使用交流电，不要漏电。用电动螺丝刀固定模块时，电动螺丝刀应接地，尽可能降低电动换向器火花产生的电磁波。

- To reduce the amount of static electricity generated, do not conduct assembling and other work under dry conditions. To reduce the generation of static electricity be careful that the air in the work is not too dry. A relative humidity of 50%-60% is recommended. As far as possible make the electric potential of your work clothes and that of the work bench the ground potential.

- 为减少静电产生，不要在干燥环境中组装或其它操作。为降低静电，工作场地一定不要太干燥。建议相对湿度为 50%-60%。尽可能使你的工作服和工作台接地。

- The LCD module is coated with a film to protect the display surface. Exercise care when peeling off this protective film since static electricity may be generated.

- 液晶显示模块表面有一个保护膜。需要小心操作以减少撕保护膜时静电的产生。

13.1.13 Since LCM has been assembled and adjusted with a high degree of precision, avoid applying excessive shocks to the module or making any alterations or modifications to it.

由于液晶显示模块由高精度装配和调节制成，应避免对模块过大的冲击或做任何更改。

- Do not alter, modify or change the shape of the tab on the metal frame.

- 不要改动金属架上的翼片形状。

- Do not make extra holes on the printed circuit board, modify its shape or change the positions of components to be attached.

- 不要在印制电路板上钻额外的孔，修改形状或更改印制线路板上元件的位置。

- Do not damage or modify the pattern writing on the printed circuit board.

- 不要更改或损坏印制线路板上的图案。

- Absolutely do not modify the zebra rubber strip (conductive rubber) or heat seal connector.

- 绝对不要更改斑马条（导电胶条）或导电纸连接器。

- Except for soldering the interface, do not make any alterations or modifications with a soldering iron.

- 除焊接接口外，不要用烙铁做任何更改。

- Do not drop, bend or twist the LCM.

- 不要跌、弯和扭模块。

13.2 Handling precaution for LCM 模块操作规范

13.2.1 LCM is easy to be damaged. Please note below and be careful for handling.

液晶显示模块很容易被损坏。请注意以下并小心操作

13.2.2 Correct handling: 正确操作：

As above picture, please handle with anti-static gloves around LCM edges.

像上面的图片,请戴抗静电手套,并拿模块边缘。

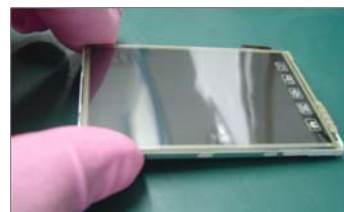

13.2.3 Incorrect handling: 错误操作:

1) Please don't hold the surface of panel.

请不要拿着面板的表面。



2) Please don't touch IC directly.

不要直接地触摸 IC



3) Please don't stack LCM.

不要把模块叠在一起



4) Please don't operate with sharp stick such as pens.

请不要用尖锐的物体来操作，例如用笔尖

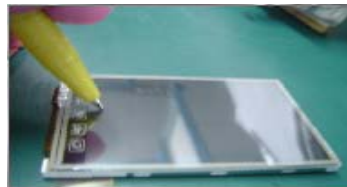

5) Please don't stretch interface of output, such as FPC cable.

请不要拉扯输出接口，如接口线

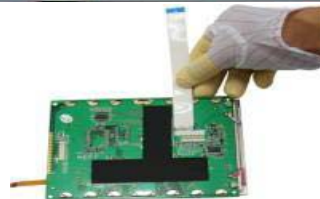

6) Please don't hold the surface of IC.

请不要拿着 IC 的表面



13.3 Storage Precautions 储存注意事项

13.3.1 When storing the LCD modules, the following precaution are necessary.

液晶显示模块的存储依照以下几点：

13.3.1.1 Store them in a sealed polyethylene bag. If properly sealed, there is no need for the desiccant.

使用聚乙烯袋密封，如果密封得当，不需要干燥剂。

13.3.1.2 Store them in a dark place. Do not expose to sunlight or fluorescent light, keep the temperature

between 0°C and 35°C, and keep the relative humidity between 40%RH and 60%RH.

避光保存，避免直接暴露在太阳光或 荧光灯下，保持温度在0~35摄氏度之间,保持相对湿度在40%RH和 60%RH之间。

13.3.1.3 The polarizer surface should not come in contact with any other objects (We advise you to store them in the anti-static electricity container in which they were shipped).

偏光片表面避免接触其他物质（建议在货运时存放防静电包装中）。

13.3.2 Others 其它

13.3.2.1 Liquid crystals solidify under low temperature (below the storage temperature range) leading to defective orientation or the generation of air bubbles (black or white). Air bubbles may also be generated if the module is subject to a low temperature.

液晶在低温会凝固（低于储存温度范围以下），会导致缺陷或产生气泡（黑或白）。如果模块处于低温下，也会产生气泡。

13.3.2.2 If the LCD modules have been operating for a long time showing the same display patterns, the display patterns may remain on the screen as ghost images and a slight contrast irregularity may also appear. A normal operating status can be regained by suspending use for some time. It should be noted that this phenomenon does not adversely affect performance reliability.

如果液晶显示模块长时间工作于同一个显示图案，换屏时会出现鬼影和轻微的对对比度不均。停止使用一段时间后后可恢复到正常状态。此现象不会严重影响性能可靠性。

13.3.2.3 To minimize the performance degradation of the LCD modules resulting from destruction caused by static electricity etc., exercise care to avoid holding the following sections when handling the modules.

为最小限度地降低由静电等对液晶显示模块性能的破坏，使用模块时避免接触下列区域：

13.3.2.3.1 - Exposed area of the printed circuit board.

- 印制电路板裸露区域。

13.3.2.3.2 -Terminal electrode sections.
- 印制电路板引出端子区域。

13.4 Using LCD modules 使用液晶显示模块

13.4.1 Installing LCD Modules 安装液晶显示模块

The hole in the printed circuit board is used to fix LCM as shown in the picture below. Attend to the following items when installing the LCM.

印制线路板上的孔用来固定液晶显示屏，如下图所示。安装液晶显示模块时，请注意以下事项：

13.4.1.1 Cover the surface with a transparent protective plate to protect the polarizer and LC cell.

贴一层透明保护膜来保护偏光片和液晶盒。

13.4.1.2 When assembling the LCM into other equipment, the spacer to the bit between the LCM and the fitting plate should have enough height to avoid causing stress to the module surface, refer to the individual specifications for measurements. The measurement tolerance should be 0.1mm.

将模块安装进入其它设备时，模块和安装板之间间隔应有足够的高度以避免模块表面受压。参照专业度量技术标准。量度公差应是 0.1毫米。

13.4.2 Precaution for assemble the module with BTB connector:

用板对板连接器安装液晶显示模块注意事项：

Please note the position of the head and socket connector position, don't assemble or assemble like the method which the following picture shows

请注意连接器的公母座的连接位置，请参看下图所示的装配方式。

13.4.2 1 Correct handling : 正确方式

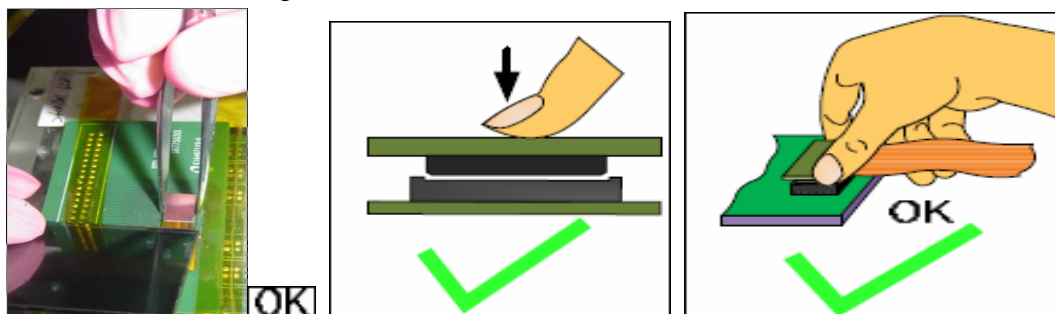

13.4.2 2 Incorrect handling: 错误方式



13.4.3 Precaution for soldering the LCM 焊接模块注意事项

	Manual soldering 手工焊接	Machine drag soldering 机器拖焊	Machine press soldering 机器压焊
No RoHS Product 非环保产品	290°C ~350°C. Time : 3-5S.	330°C ~350°C. Speed : 4-8 mm/s.	300°C ~330°C. Time : 3-6S. Press: 0.8~1.2Mpa
RoHS Product 环保产品	340°C ~370°C. Time : 3-5S.	350°C ~370°C. Time : 4-8 mm/s.	330°C ~360°C. Time : 3-6S. Press: 0.8~1.2Mpa

13.4.3.1 If soldering flux is used, be sure to remove any remaining flux after finishing to soldering operation (This does not apply in the case of a non-halogen type of flux). It is recommended that you protect the LCD surface with a cover during soldering to prevent any damage due to flux spatters.

如果使用助焊剂，完成焊接后一定要清除剩余的助焊剂（除非卤化物助焊剂）。建议焊接时用盖子保护显示屏面以避免因焊剂油溅出造成损坏。



13.4.3.2 When soldering the electroluminescent panel and PC board, the panel and board should not be detached more than three times. This maximum number is determined by the temperature and time conditions mentioned above, though there may be some variance depending on the temperature of the soldering iron. 焊接背光源和线路板时，不应装卸多于三次。尽管焊接温度会有变化，但不应超过上面提到的焊接温度和时间最大值。

13.4.3.3 When remove the electroluminescent panel from the PC board, be sure the solder has completely melted, the soldered pad on the PC board could be damaged.

从线路板上移除背光源时，要保证焊锡已完全熔化，不要损坏线路板上的焊接位。

13.4.4 Precautions for Operation 工作运行注意事项:

13.4.4.1 Viewing angle varies with the change of liquid crystal driving voltage (VLCD). Adjust VLCD to show the best contrast.

视角应随液晶驱动电压(VLCD)变化而变化.调整VLCD 可显示最好的对比度。

13.4.4.2 It is an indispensable condition to drive LCD's within the specified voltage limit since the higher voltage then the limit cause the shorter LCD life. An electrochemical reaction due to direct current causes LCD's undesirable deterioration, so that the use of direct current drive should be avoided.

在液晶驱动电压内来操作模块是必要的。超过限定电压会缩短液晶寿命。直流电会引起液晶的电化学反应，导致液晶老化，因此要避免直流电驱动液晶。

13.4.4.3 Response time will be extremely delayed at lower temperature than the operating temperature range and on the other hand at higher temperature LCD's show dark color in them. However those phenomena do not mean malfunction or out of order with LCD's, which will come back in the specified operating temperature.

液晶响应时间在低温时比常温要慢，高温时，液晶底色会深。然而,这并不是指液晶显示屏工作异常，显示屏在温度恢复时，效果会恢复正常。

13.4.4.4 If the display area is pushed hard during operation, the display will become abnormal. However, it will return to normal if it is turned off and then back on.

如果在运行过程中显示区受到挤压,显示将会异常.然而停止挤压,将恢复正常。

13.4.4.5 A slight dew depositing on terminals is a cause for electro-chemical reaction resulting in terminal open circuit. Usage under the maximum operating temperature, 50%RH or less is required.

接线端冷凝会引起电化学反应而断路。因此必须在最大的操作温度之内，湿度小于50% 的条件下使用液晶显示模块。

13.4.4.6 Input logic voltage before apply analog high voltage such as LCD driving voltage when power on. Remove analog high voltage before logic voltage when power off the module. Input each signal after the positive/negative voltage becomes stable.

开机时，先通逻辑电压，再接通模拟高压，例如显示屏的驱动电压。关机时，先断开模拟高压，再关逻辑电压。正负电源都稳定后再送控制信号。

13.4.4.7 Please keep the temperature within the specified range for use and storage. Polarization degradation, bubble generation or polarizer peel-off may occur with high temperature and high humidity.

模块请在规格范围内操作和存储。高温高湿可能会引起偏光片退化，起泡，分层等问题。

13.4.5 Safety 安全

13.4.5.1 It is recommended to crush damaged or unnecessary LCDs into pieces and wash them off with solvents such as acetone and ethanol, which should later be burned.

建议将损坏的液晶显示屏压成碎片，用溶剂诸如丙酮,乙醇冲洗掉，迟后烧掉。

13.4.5.2 If any liquid leaks out of a damaged glass cell and comes in contact with the hands, wash off thoroughly with soap and water.

如果液晶从液晶盒泄漏出且与沾在手上,要用肥皂和水彻底清洗。

13.4.6 Limited Warranty 有限责任

Unless agreed between TOPFOISON and the customer, TOPFOISON will replace or repair any of its LCD modules which are found to be functionally defective when inspected in accordance with TOPFOISON LCD acceptance standards (copies available upon request) for a period of one year from date of production. Cosmetic/visual defects must be returned to TOPFOISON within 90 days of shipment. Confirmation of such date shall be based on data code on product. The warranty liability of TOPFOISON limited to repair and/or replace on the terms set forth above.

TOPFOISON will not be responsible for any subsequent or consequential events.

除拓丰和客户之间另有协议外，自生产之日起一年内，根据拓丰的液晶显示屏品质标准，拓丰将对有功能缺陷的液晶显示模块换货或返工。外观/视觉缺陷产品，必须在出货后 90 天内归还拓丰。以产品上标识日期



为准。拓丰保修责任仅限于对符合上述规定的货品进行返工和/或换货。对此后发生的任何情况，拓丰均不承担任何责任。

13.4.7 Return LCM under warranty 模块保修

13.4.7.1 No warranty can be granted if the precautions stated above have been disregarded. The typical examples of violations are :

保修是以上述注意事项未被忽视为先决条件的。典型的违反例子如下:

13.4.7.1.1 - Broken LCD glass.

-断裂的液晶显示屏玻璃。

13.4.7.1.2 - PCB eyelet is damaged or modified.

-印制线路板孔修改或损坏。

13.4.7.1.3 -PCB conductors damaged.

-线路板导体损坏。

13.4.7.1.4 - Circuit modified in any way, including addition of components.

-线路随意变更，包括元件变化。

13.4.7.1.5 - PCB tampered with by grinding, engraving or painting varnish.

-印制电路板已修改，如研磨，雕刻，绘涂等。

13.4.7.1.6 - Soldering to or modifying the bezel in any manner.

-焊接或变动模块

13.4.7.2 Module repairs will be invoiced to the customer upon mutual agreement. Modules must be returned with sufficient description of the failures or defects. Any connectors or cable installed by the customer must be removed completely without damaging the PCB eyelet, conductors and terminals.

模块维修清单将按双方协议送呈客户。模块详细缺陷描述须模块一并退回。顾客安装的连接器和电缆必须在破坏线路板孔，线路和引线端条件下全部移去。

14. Prior consult matter 提前商议事项

13.1 For TOPFOISON standard products, we keep the right to change material, process ... for improving the product property without prior notice to our customer.

对于拓丰的标准产品，我们保留在不通知客户的情况下,为提高产品性能而改变原材料及加工方法等的权利。

13.2 For OEM products, if any changes are needed which may affect the product property, we will consult with our customer in advance.

对于OEM产品，如果需要做任何会影响到产品性能的改变，我们会提前和客户商议。

13.3 If you have special requirement about reliability condition, please let us know before you start the test on our samples.

如对可靠性条件有特殊要求，请在模块测试前通知我们。

15. Outline Dimension 外形尺寸

NO.	Item	Dimension(L*W*H)(mm) 规格	Quantity 数量	Quantity 产品数量
1	Tray(盘子)	350*262*15	1(个)	--
2	Inside Carton (内箱)	400*320*150	1(个)	--
3	Outside Carton(外箱)	420*330*350	1(个)	--

16. Package 包装

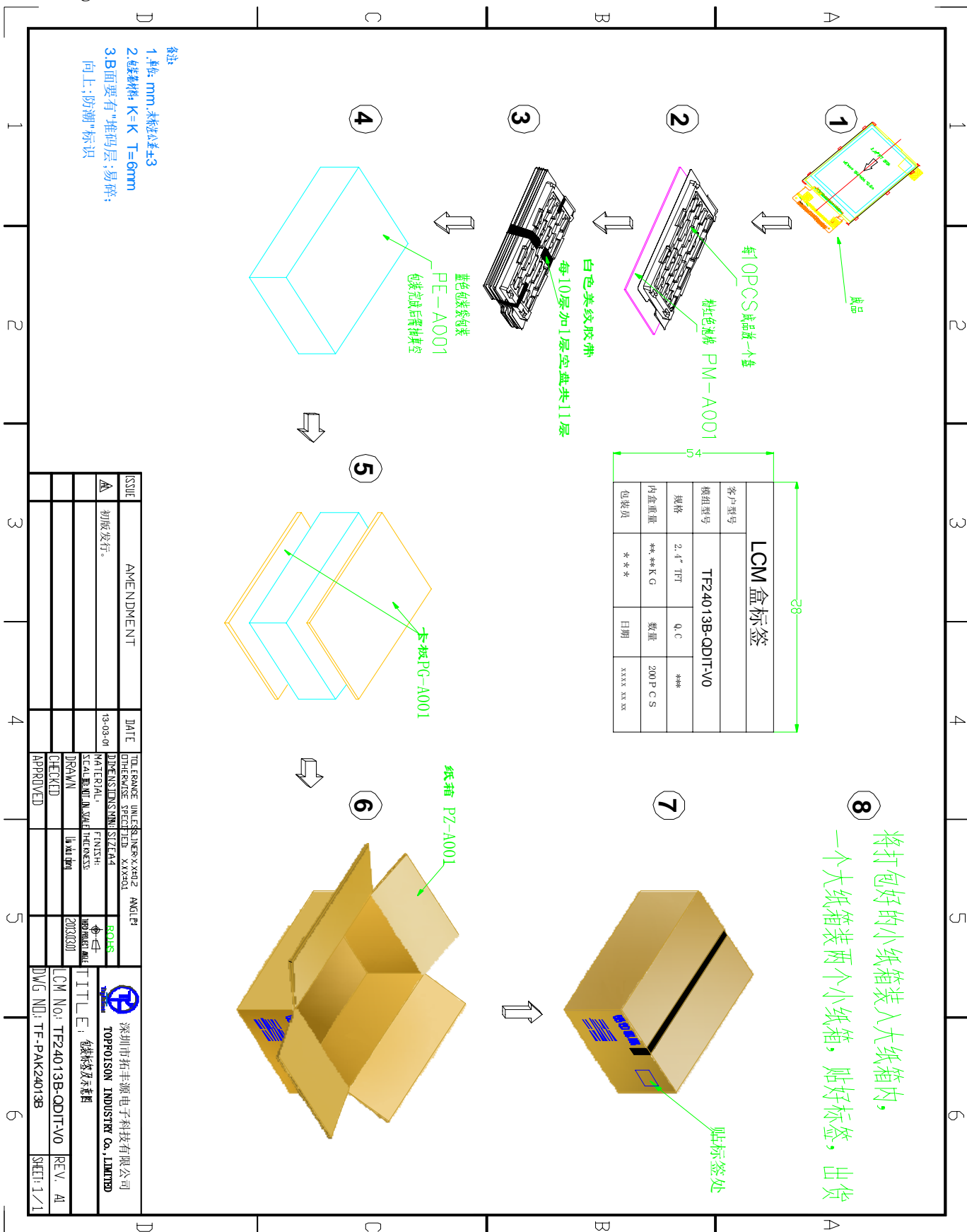

ISSUE	AMENDMENT	DATE	TOLERANCE UNLESS SPECIFIED	ANG1 P1
A	初版发行。	19-03-01	ROHS	深圳市拓丰源电子科技有限公司
			DRAWN	物料部
			CHECKED	20191201
			APPROVED	DWG NO.: TF-PAK24013B



深圳市拓丰源电子科技有限公司

TOPFOISON INDUSTRY Co., LIMITED

17. Technical support 技术支持

Name: Smile LIU

Email: smile.liu@topfoison.com

Fax: 86-0755-33512776

Tel: 86-0755-33512775

Web: www.topfoison.com

**Address: B1607, Chamber of Commerce Information Building, Qiaotou, Fuyong Town,
Bao'an District, Shenzhen City, Guangdong Province**

END(完)