

DTMF decoder kit with multiple outputs, serial (RS232 compatible) & morse transpond.

Our DTMF decoder kit has 6 NPN open collector darlington outputs that can be switched on/off remotely with or without a 4 digit security code. The decoder also has a TX keying output to key a transmitter for transponding a morse confirmation. An audio output is included for the morse audio tones. The PCB has been designed to allow 3 input configurations - unbalanced audio, an electret microphone or balance audio to be connected.

An alternative option is to use the kit as a DTMF to PC interface allowing DTMF tones to be displayed in say Hyperterminal (see below).

To turn on/off an output send the decoder it's ID followed by the output number and * for ON or # for OFF e.g. 12341* turns on output 1 and 12342# turns off output 2 etc.

To toggle an output send e.g. 12341A and the state of the output will be changed to the oposite of it's previous state - the morse transpond will be confirmation of the new state. To pulse an output send e.g. 12341B and the output will turn on for 0.5 seconds - the morse transpond will be e.g. 1P.

* You can now use 9 or A and 8 or B on the latest firmware.

For confirmation of the desired switching of an output the decoder will key a Transmitter and respond in morse code, e.g turning on output 1 will respond as 1 ON in morse, and turning off output 2 will respond as 2 OFF. As there are only 6 digits and 3 letters to learn, morse shouldn't put you off. There is a 2 second transpond delay followed by a 400ms link establishment delay to allow for CTCSS (if used).

Sending the turn off code for the dummy output zero e.g. 12340# will transpond _._._ OFF but won't affect any outputs. This is useful for checking if in radio range.

The 4 digit security ID can be changed by simply fitting a jumper to CN7, powering up the decoder and sending it a new 4 digit ID, then remove power, remove jumper and power-up and the new ID is set. If no ID is required then simply program the ID as 0000 and on next power-up no ID will be needed and e.g. 1* will turn on output 1.

There is an added feature on the current DTMF decoder kits, the ability to turn off the morse transpond has been added. When setting the 4 digit identity add a fifth digit as

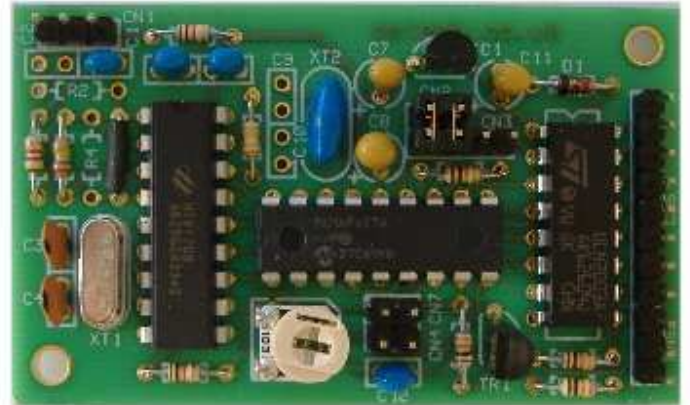

All parts shown in the assembled photo are included as well as some extras for alternative input configuration.

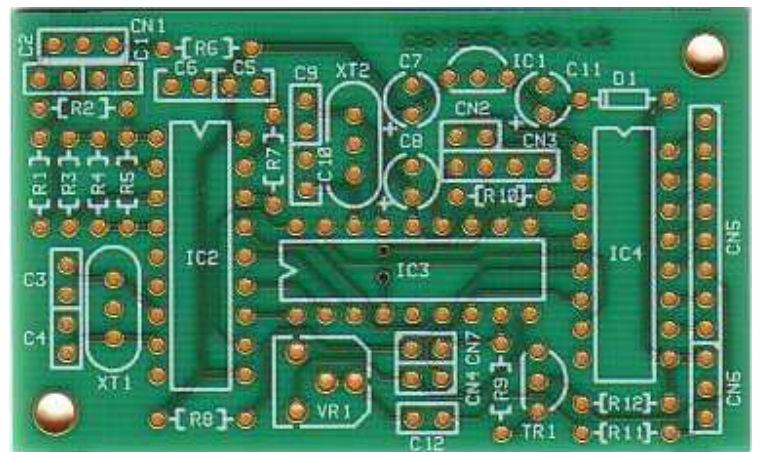

A circuit diagram is on the last page of this document.

A pdf data sheet for the HT9170B maybe viewed at:-

www.cstech.co.uk/ht9170.pdf

9 and the morse transpond will be turned off. Any other character in the fifth position turns the morse transpond on. When supplied the identity is supplied as 1234 and the fifth digit is set as 0. You do not need to program the fifth digit if transpond is desired, the fifth digit is not used as part of the identity.

If using the kit for DTMF to serial - program the ID as 2320 and on next power-up decoded DTMF tones will be output as RS232 (4800 baud 8N1) compatible serial on the TX keying output, (fit the pull-up resistor R12 for this use).

The PCB is a high quality double sided PTH (plated through hole) 1.6mm FR4 (Fiberglass) board 64 x 38mm in size.

A 4 pin programming header is also provided to allow in-circuit re-programming of the PIC.

There are many sources of DTMF, tone pads, two-way radio microphone keypads, telephone systems, and even your mobile phone's keypad tones.

As an example if using as a DTMF code lock, use a mobile phone's keypad tones and use the microphone option for pick up.

Applications include:-

- 1, DTMF to PC for display of decoded DTMF.
- 2, DTMF remote control with 6 O/P's over radio or mobile phone.
- 3, DTMF code lock.

DTMF Decoder Parts List

IC1	78L05
IC2	HT9170B
IC3	PIC16F627A
IC4	ULN2003
TR1	BC184L
D1	1N4148
XT1	3.579MHz crystal
XT2	4MHz 3 pin ceramic resonator with internal caps
R1*	4K7
R2, 4	not fitted
R5	wire link
R3*	270K
R6*, 8	1K
R7	330K
R9, 10, 11, 12*	10K
VR1	10K variable
C1, 5, 6, 12	100nF (marked 104)
C2	not fitted
C3, 4	22pf
C7, 8, 11	1uF (marked 105) observe polarity
C9, 10	not fitted
CN1, 6	3 pins
CN2, 4, 7	2 Pins
CN3	4 Pins
CN5	8 pins

Also supplied:-

DTMF decoder PCB Iss A
3 x 0.1" jumper links
2 x 10K for alternative input configuration

*Note:-

Only fit R6 if using an electret microphone as input.

Only fit R1 & R3 as 4K7 & 270K for use with a microphone, otherwise fit R1 & R3 as 10K or calculate a custom input configuration from HT9170 datasheet.

Only fit R12 if using for serial output.

DTMF Decoder application notes follow.

There are 3 input configurations for our DTMF decoder, electret microphone, un-balance and balanced, the 3 options are shown below in the circuit extracts. The HT9170 DTMF decoder chip has a wide input signal range from approx. 27mV to 775mV, but as it contains an op-amp at it's input and the op-amp gain can be altered using different resistor values, many combinations can be achieved.

Six outputs capable of directly driving relays can be switched on/off, a radio transmitter can be keyed and a Morse audio response given.

An alternative use of the decoder kit is for DTMF to RS232 translation.

Please see notes below.

The electret microphone input version provides power to a microphone insert via R6 (1K) and using R1 at 4K7 and R3 at 270K to set the decoder chip's input op-amp gain to x57 the sensitivity allows pick-up from a DTMF tone pad at a couple of inches. A speaker phone, two-way radio speaker or the keypad tones from a mobile can be picked up 6 to 12 inches away.

We do not recommend increasing the input gain any higher.

Connect the microphone between pins 1 and 2 (2 = Gnd).

Resistors are provided in the kit for this option.

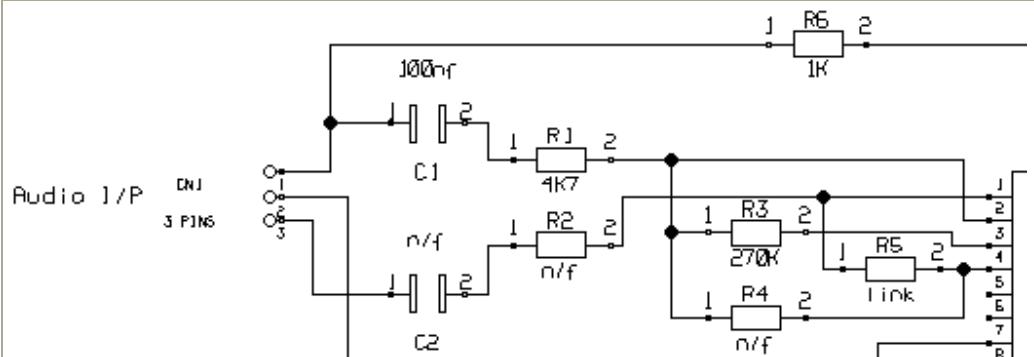

This example offers an un-balanced audio input, using 10K resistors for R1 and R3 sets the decoder chip's input gain at x1 and gives an input impedance around 10K, R6 is omitted and this configuration can be fed directly from say the Packet modem RX audio output of a Ham radio.

If it is desired to change the input gain then increase R3 for higher gain and decrease R3 for lower gain.

Connect the signal source between pins 1 and 2 (2 = Gnd).

Resistors are provided in the kit for this option.

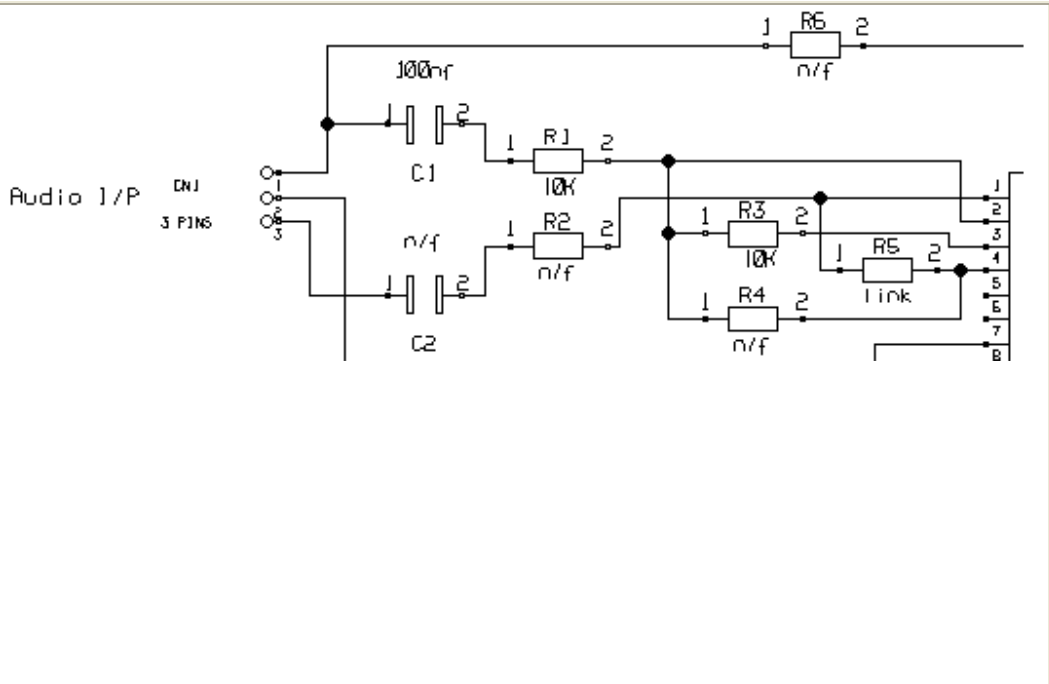

The balanced audio input can be connected to say the earphone audio output of a GSM modem, with the values shown the decoder chip's input gain is also x1, however this can be changed as required, see the HT9170 data sheet for the calculations.

Connect the signal source between pins 1 and 3.

Resistors are NOT supplied in the kit for this option as there are many combinations that could be required.

62K and 36K can be used instead of 60K and 37.5K

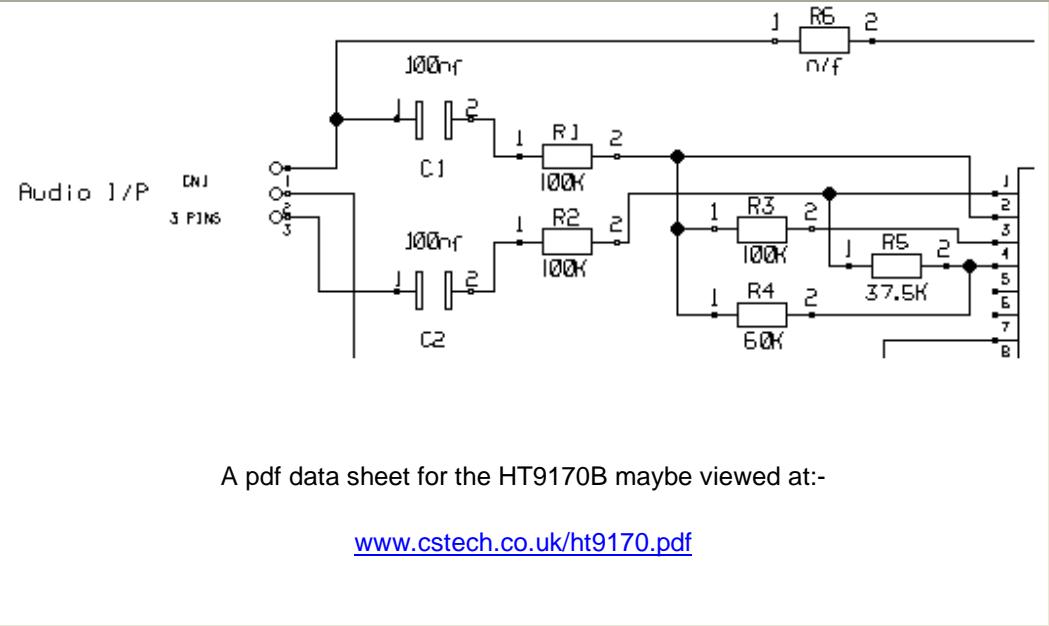

A pdf data sheet for the HT9170B maybe viewed at:-

www.cstech.co.uk/ht9170.pdf

Our decoder has 6 outputs that can be switched on/off using DTMF, they are all implemented as open collector NPN's in the ULN2003 Darlington driver chip, there are also 'back EMF' protection diodes on chip with their common connected to the +8 to 15V supply pin, when driving relays they should be connected between the output pin and the + supply, we recommend using 12V relays with coils of at least 120 ohms and a 12V supply.



Please fit the two jumpers on CN2 shown in this photo just above the PIC, otherwise outputs 1 and 2 will not work. CN2 & 3 are provided to allow in-circuit programming of the PIC with your own code.

The open collector TX keying output is implemented with a BC184L NPN transistor, there is no protection diode and this output is intended to ground a radio transceiver's electronic PTT input.

For this use R12 should NOT be fitted.

The morse audio output can be connected to a radio transceiver's mic input or packet modem TX audio input, so that the Morse code response can be heard at the remote controlling radio. If using with a GSM modem this audio can be fed into the modems mic input.

A variable resistor on the decoder allows for adjustment of the audio level, however if the adjustment is too close to the minimum end, add a resistor in series with the audio output.

Our decoder kit can alternatively be used as a DTMF to serial translator so that DTMF tones can displayed on a PC using e.g. hyperterminal. If this option is chosen R12 must be fitted (10K), then simply program the decoder's 4 digit ID as 2320 using a DTMF source and the serial output can be connected directly to a PC serial port without a level translator being reqd. Baud rate is 4800 8N1.

Connect the serial output to pin 2 and Gnd to pin 5 of a 9 pin D socket.

[A circuit diagram is on the last page of this document.](#)

R1 & R3 set input op-amp gain
 C2, R2, R4 & R5 are for balanced input
 R5 = mic power feed option

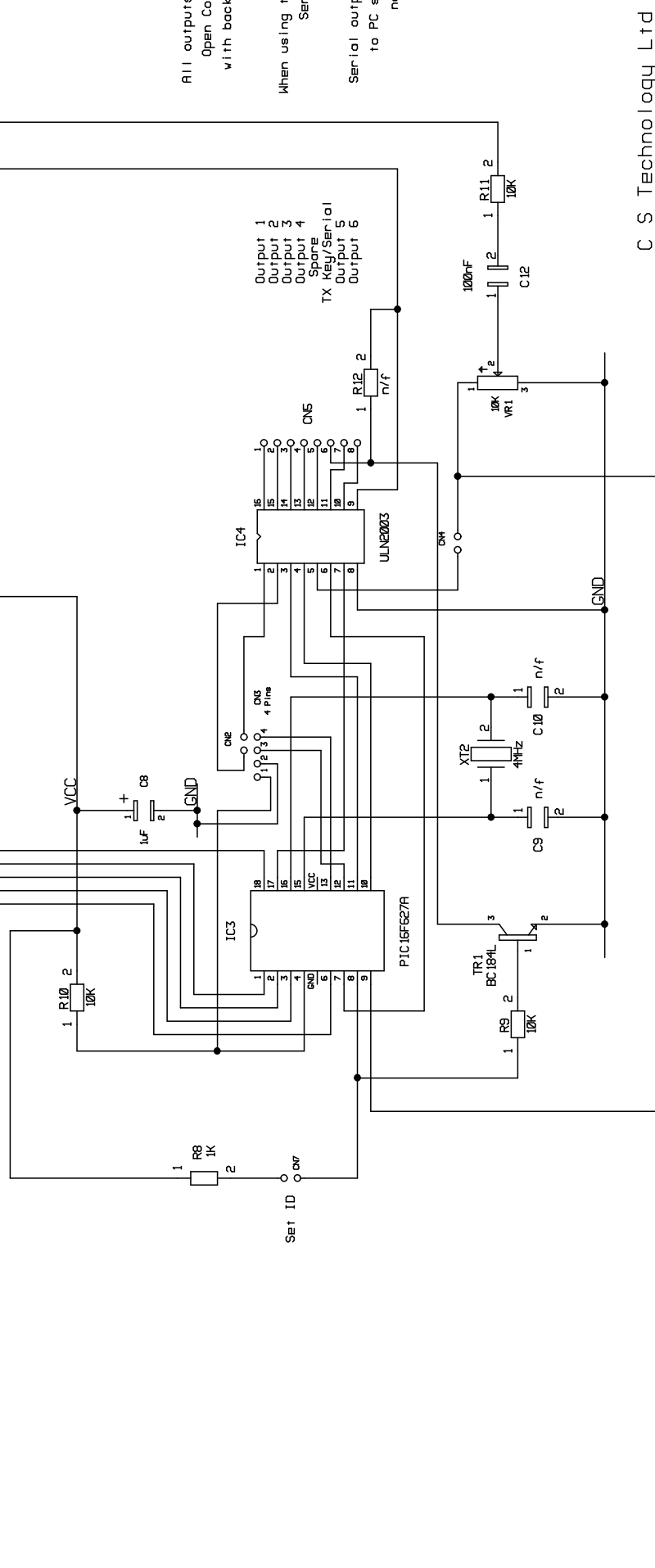
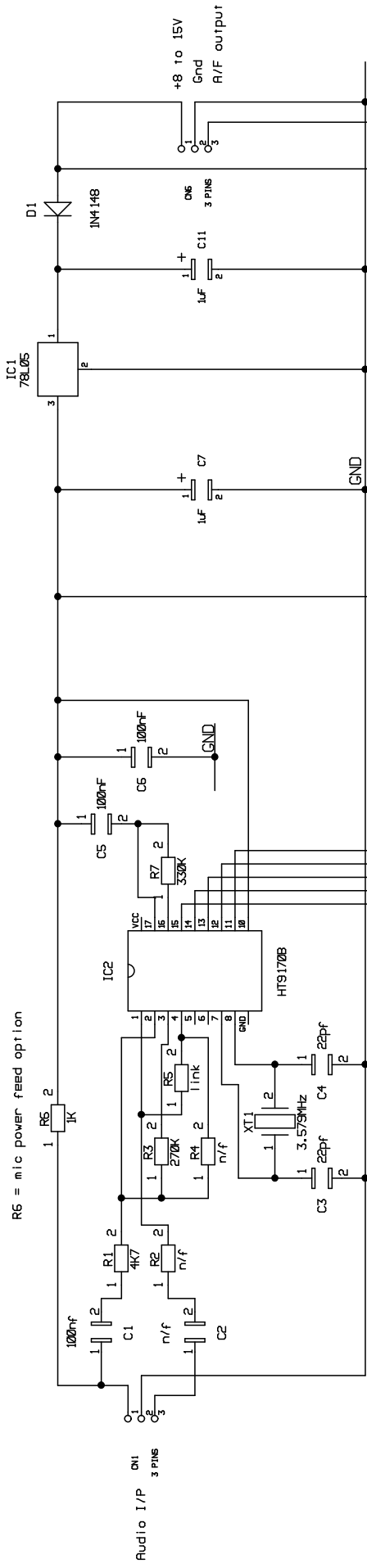

All outputs (except TX/serial) are
 Open Collector Darlington
 with back EMF protection diodes

When using the TX Key/Serial output for
 Serial f11 R12 as 10K

Serial output will connect directly
 to PC serial input (pin 2)
 no buffer reqd.