

**OLYMPUS**

**CAMERA**

**DIGITAL CAMERA**

**C-740 Ultra Zoom**

**REFERENCE MANUAL**

**<Click Here>**

**CAMERA OPERATION MANUAL**

Explanation of digital camera functions and operating instructions.

**DIGITAL CAMERA - PC CONNECTION  
OPERATION MANUAL**

Explanation of how to download images between your digital camera and PC.

# **OLYMPUS**

**CAMERA**  
DIGITAL CAMERA

## **C-740 Ultra Zoom**

### **REFERENCE MANUAL**

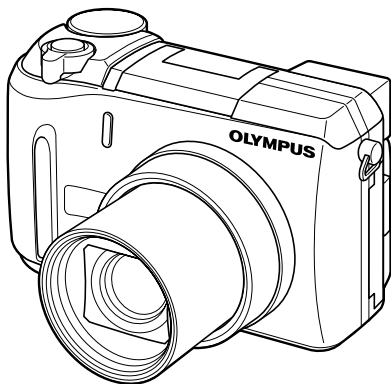

- 
- Thank you for purchasing an Olympus digital camera. Before you start to use your new camera, please read these instructions carefully to enjoy optimum performance and a longer service life. Keep this manual in a safe place for future reference.
  - We recommend that you take test shots to get accustomed to your camera before taking important photographs.
  - In the interest of continually improving products, Olympus reserves the right to update or modify information contained in this manual.

## For customers in North and South America

### For customers in USA

Declaration of Conformity

Model Number : C-740 Ultra Zoom

Trade Name : OLYMPUS

Responsible Party : Olympus America Inc.

Address : 2 Corporate Center Drive, Melville, New York  
11747-3157 U.S.A.

Telephone Number : 631-844-5000

Tested To Comply With FCC Standards  
FOR HOME OR OFFICE USE

This device complies with Part 15 of the FCC rules. Operation is subject to the following two conditions:

- (1) This device may not cause harmful interference.
- (2) This device must accept any interference received, including interference that may cause undesired operation.

### For customers in Canada

This Class B digital apparatus meets all requirements of the Canadian Interference-Causing Equipment Regulations.

## For customers in Europe





"CE" mark indicates that this product complies with the European requirements for safety, health, environment and customer protection. "CE" mark cameras are intended for sales in Europe.

## Trademarks

- IBM is a registered trademark of International Business Machines Corporation.
- Microsoft and Windows are registered trademarks of Microsoft Corporation.
- Macintosh is a trademark of Apple Computer Inc.
- All other company and product names are registered trademarks and/or trademarks of their respective owners.
- The standards for camera file systems referred to in this manual are the "Design Rule for Camera File System/DCF" standards stipulated by the Japan Electronics and Information Technology Industries Association (JEITA).

	<b>Contents</b>	P.4	
	<b>Names of parts</b>	P.10	
<b>Introduction of the camera's functions</b>	<b>Getting started</b>	P.17	<b>1</b>
	<b>Using the menus</b>	P.32	<b>2</b>
<b>Basic Photography</b>	<b>Shooting basics</b>	P.42	<b>3</b>
<b>Advanced Photography</b> To get that particular shot using various effects or for fine-tuning the settings.	<b>Flash</b>	P.55	<b>4</b>
	<b>Advanced shooting</b>	P.63	<b>5</b>
	<b>Adjusting the image quality and exposure</b>	P.91	<b>6</b>
For playing back and editing pictures	<b>Playback</b>	P.108	<b>7</b>
Settings that make the camera easier to operate.	<b>Useful functions</b>	P.128	<b>8</b>
Printing pictures	<b>Print setting</b>	P.152	<b>9</b>
Troubleshooting and other information	<b>Miscellaneous</b>	P.163	<b>10</b>
	<b>Specifications</b>	P.184	
	<b>Glossary of terms</b>	P.186	
	<b>Index</b>	P.189	



# Contents

Contents .....	4
Names of parts .....	10
Camera .....	10
Viewfinder and monitor indications .....	12
How to use this manual .....	16
<b>1 Getting started</b>	<b>17</b>
<hr/>	
Attaching the strap .....	17
Loading the batteries .....	18
Selecting optional batteries or an AC adapter .....	20
Inserting a card .....	22
Card basics .....	22
Removing the card .....	23
Power on/off .....	24
Startup/Shutdown screen .....	25
If the card is not recognized (card check) .....	25
Selecting a language  .....	26
Setting the date and time  .....	28
Adjusting the viewfinder .....	30
Holding the camera .....	31
<b>2 Using the menus</b>	<b>32</b>
<hr/>	
About the menus .....	32
How to use the menus .....	33
Shortcut menus .....	35
Mode Menu .....	37
<b>3 Shooting basics</b>	<b>42</b>
<hr/>	
Shooting modes .....	42
Taking still pictures .....	46

If correct focus cannot be obtained . . . . .	49
Using the Focus Lock function . . . . .	49
Subjects that are difficult to focus on . . . . .	50
Recording movies  . . . . .	51
Zoom . . . . .	53
Using the optical zoom . . . . .	53
DIGITAL ZOOM - Using the digital zoom . . . . .	54





## 4 Flash 55





---

Flash shooting  . . . . .	55
Using the slow synchronization flash  SLOW . . . . .	61
Flash intensity control  . . . . .	62









## 5 Advanced shooting 63

---



A/S/M mode . . . . .	63
Aperture priority shooting <b>A</b> . . . . .	64
Shutter priority shooting <b>S</b> . . . . .	65
Manual shooting <b>M</b> . . . . .	66
Using My Mode  . . . . .	67
Focusing applications . . . . .	68
AF MODE - Changing the focus range . . . . .	68
FULLTIME AF - A reliable time-saving way to focus . . . . .	69
AF AREA - Changing the position of the AF target mark . . . . .	70
AF LOCK - Locking the focus . . . . .	71
Manual focus . . . . .	73
Metering  . . . . .	75
Spot metering . . . . .	75
MULTI METERING . . . . .	76
AE LOCK - Locking the exposure <b>AEL</b> . . . . .	78
Macro mode shooting  . . . . .	80
Super macro mode shooting  . . . . .	81
Self-timer shooting  . . . . .	82









Sequential shooting  <b>HI</b>  <b>AF</b>  <b>BKT</b> .....	83
Sequential shooting, high speed sequential shooting and AF sequential shooting  <b>HI</b>  <b>AF</b> .....	83
Auto bracketing <b>BKT</b> .....	84
PANORAMA - Panorama shooting .....	86
2 IN 1 - Taking two-in-one pictures <b>2 IN 1</b> .....	88
FUNCTION - Adding special effects to pictures .....	90

## 6 Adjusting the image quality and exposure 91

Record mode  .....	91
Selecting a record mode .....	93
3:2 Resolution .....	95
ENLARGE SIZE .....	95
ISO sensitivity .....	96
Exposure compensation  .....	97
White balance <b>WB</b> .....	98
Auto white balance .....	98
Preset white balance .....	99
One-touch white balance  .....	99
White balance adjustment  .....	101
SHARPNESS  .....	102
CONTRAST  .....	103
SATURATION  <b>RGB</b> .....	104
NOISE REDUCTION .....	105
Histogram display  .....	106





## 7 Playback 108

Viewing still pictures  .....	108
<b>QUICK VIEW</b> .....	109
Close-up playback  .....	110
Index display  .....	111
Selecting the number of pictures .....	112

Slideshow 	113
Viewing movies 	114
Editing movies	116
INDEX - Creating an index	116
EDIT - Editing a movie	118
Playback on a TV	120
Picture rotation 	121
Editing still pictures	122
Resizing 	122
Trimming 	123
Protecting pictures 	125
Erasing pictures 	126
Single-frame erase 	126
All-frame erase 	127

## 8 Useful functions





## 128

ALL RESET – Saving the camera's settings	128
CUSTOM BUTTON 	130
Setting the custom button	131
Using the custom button	132
SHORT CUT	133
Setting the shortcut menu	134
Using the shortcut menu	135
MY MODE SETUP 	136
CARD SETUP - Formatting Cards 	139
Information display <b>INFO</b>	141
Monitor/viewfinder brightness adjustment 	142
REC VIEW	143
SLEEP - Sleep Timer	144
Beep 	145
POWER ON/OFF SETUP - Power on/off display setting	146
SCREEN SETUP	147
FILE NAME	148
PIXEL MAPPING	149



Measurement units <b>m/ft</b> .....	150
VIDEO OUT - Video output selection .....	151



## 9 Print setting 152

How to print pictures .....	152
All-frame reservation  .....	154
Single-frame reservation  .....	156
Trimming  .....	159
Resetting print reservation data  .....	161

## 10 Miscellaneous 163

Error codes .....	163
Troubleshooting .....	164
List of menus .....	171
List of factory default settings .....	177
Modes and Shooting Functions .....	180
Camera maintenance .....	183
Specifications .....	184
Glossary of terms .....	186
Index .....	189

Indications used in this manual

 Note	Important information on factors which may lead to a malfunction or operational problems. Also warns of operations that should be absolutely avoided.
	Useful information and hints that will help you get the most out of your camera.
	Reference pages describing details or associated information.



# Names of parts

## Camera

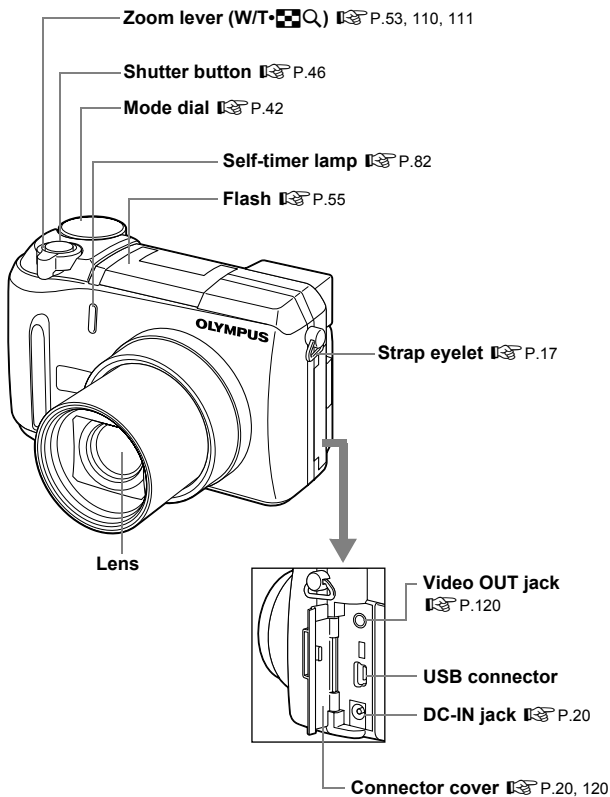

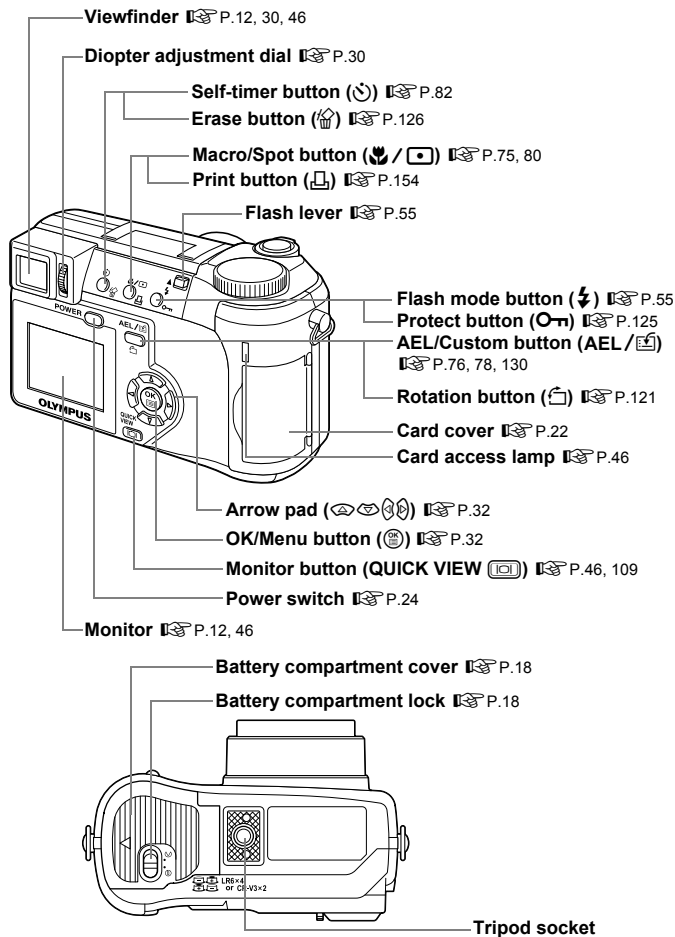









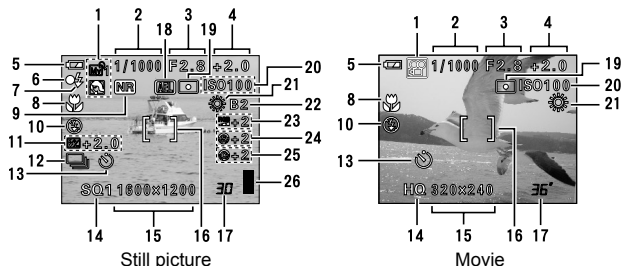









## Viewfinder and monitor indications

INFO setting allows you to select how much information to display on the screen. Screens with the Information display set to ON are shown below.

 "Information display" (P.141)

### ●Shooting modes



	Item	Indications	Ref. Page
1	Shooting modes	<b>P, A, S, M,</b>  ,  ,  ,  ,  ,  ,  ,  ,  , 	P.42
2	Shutter speed	16 – 1/1000	P.65
3	Aperture value	F2.8 – F8.0	P.64
4	Exposure compensation Exposure differential	-2.0 – +2.0 -3.0 – +3.0	P.97 P.66
5	Battery check	 	P.15
6	Green lamp		P.46
7	Flash stand-by Camera movement warning/Flash charge	 (Lights)  (Blinks)	P.57
8	Macro mode Super macro mode Manual focus	 s  MF	P.80 P.81 P.73
9	Noise reduction	<b>NR</b>	P.105

	Item	Indications	Ref. Page
10	Flash mode	SLOW1, SLOW1, SLOW2	P.55
11	Flash intensity control	-2.0 – +2.0	P.62
12	Drive	BKT	P.83
13	Self-timer		P.82
14	Record mode	TIFF, SHQ, HQ, SQ1, SQ2	P.91
15	Resolution	2048 × 1536, 1280 × 960, 640 × 480, 320 × 240 etc.	P.92
16	AF target mark	[ ]	P.46
17	Number of storable still pictures	30	P.92
	Seconds remaining	36"	P.51
18	AE lock AE memory	 	P.78
19	Spot metering		P.75
20	ISO	ISO 100, ISO 200, ISO 400	P.96
21	White Balance		P.98
22	White balance compensation	B1 – B7, R1 – R7	P.101
23	Saturation	-5 – +5	P.104
24	Sharpness	-5 – +5	P.102
25	Contrast	-5 – +5	P.103
26	Memory gauge		P.15

## ● Playback mode

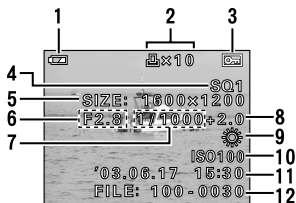

Still picture

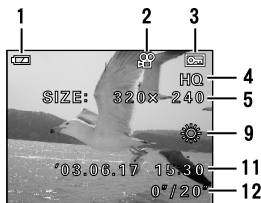

Movie

	Item	Indications	Ref. Page
1	Battery check		P.15
2	Print reservation, Number of prints Movie	x 10 	P.154 P.114
3	Protect		P.125
4	Record mode	TIFF, SHQ, HQ, SQ1, SQ2	P.91
5	Resolution	2048 × 1536, 1280 × 960, 640 × 480, 320 × 240 etc.	P.92
6	Aperture value	F2.8 – F8.0	P.64
7	Shutter speed	16 – 1/1000	P.65
8	Exposure compensation	-2.0 – +2.0	P.97
9	White Balance	WB AUTO, , , , ,	P.98
10	ISO	ISO 100, ISO 200, ISO 400	P.96
11	Date and time	'03.06.17 15:30	P.28
12	File number, Frame number Playing time/ total recording time	FILE : 100 – 0030, 30 0"/20"	P.148



Note

- The indications that appear on a movie picture that has been selected and displayed from the index display are different from those that appear when the movie picture is displayed using the movie playback function.

## ●Memory gauge

The memory gauge lights up when you take a still picture. While the gauge is lit, the camera is storing the picture on the card. The memory gauge indication changes as shown below depending on the shooting status. The indication is not displayed during movie recording.

Battery check



Memory gauge

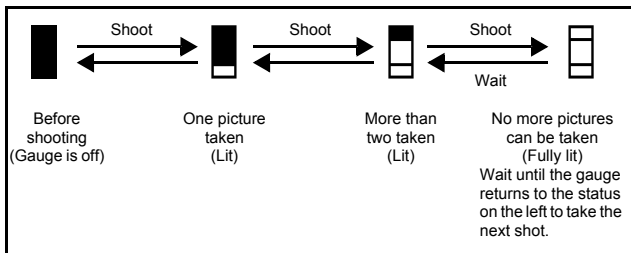

## ●Battery check

If the remaining battery power is low, the battery check indication changes as follows when the camera is turned on or while the camera is in use.

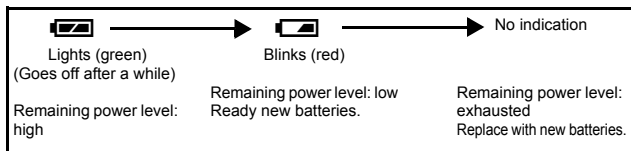





# How to use this manual

Set the mode dial to any of the marks shown here.

Follow the arrows to perform menu operations.  
For details on operating procedures, see "How to use the menus" (P.33).





**SHARPNESS** 

This function adjusts the sharpness of the image.

**Mode dial**  A/S/M P

**1** In the top menu, select **MODE MENU PICTURE SHARPNESS**, and press .  
For details, see "How to use the menus" (P.33).

**2** Press  to adjust the sharpness between **+5** and **-5**.

- To increase the sharpness (+):  
Press . The image contours are emphasized, making the image appear sharper and more vivid. Use this setting when you want to print pictures.
- To reduce the sharpness (-):  
Press . The image contours are softened. Use this setting when you want to edit images on a PC.
- When you have finished setting the sharpness, press . Press  again to exit the menu.

**6** Adjusting the image quality

  
Arrow pad  
OK button

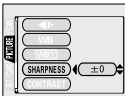

This represents the arrow pad. Only arrows applicable to the operation are shown.

This sample page is only for your reference. It may differ from the actual page in this manual.

# 1 Getting started

## Attaching the strap

- 1 Pass the lens cap string through the hole in the lens cap, then pass the other end through the loop and pull tight.
- 2 Pull the ends of the strap out of the stopper and ring.
- 3 Thread one end of the strap (A) through the string loop (attached to the lens cap in step 1). Then thread it through the strap eyelet on the camera.
- 4 Thread the end of the strap back through the ring and stopper as indicated by the arrows. Adjust the strap to the desired length.
- 5 Pull the strap through the stopper (B) to make sure it is fastened securely.
- 6 Attach the strap to the other eyelet following steps 3 to 5.

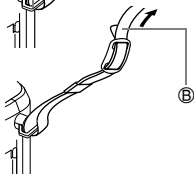
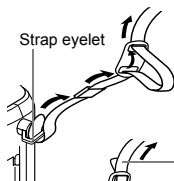
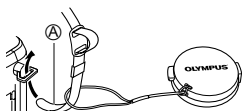
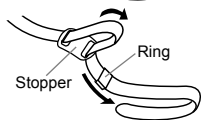
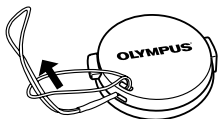

Note

- Be careful with the strap when you carry the camera, as it can easily catch on stray objects, causing injury or damage.
- Attach the strap correctly as shown above so that the camera does not fall off. If the strap is attached incorrectly and the camera falls off, Olympus is not responsible for any damages.

1

Getting started

# Loading the batteries

This camera uses two CR-V3 lithium battery packs or four AA (R6) NiMH batteries, NiCd batteries, alkaline batteries or lithium batteries.

## Important

- CR-V3 lithium batteries cannot be recharged.
- Do not peel off the label from a CR-V3 lithium battery pack.
- Manganese (zinc-carbon) batteries cannot be used.

### 1 Make sure the camera is turned off.

- The monitor is off.
- The viewfinder is off.
- The lens is not extended.

### 2 Slide the battery compartment lock from to .

Battery compartment cover

Battery compartment lock

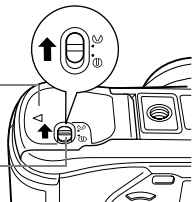

### 3 Slide the battery compartment cover in the direction of , then lift in the direction of .

- Use the ball of your finger to slide the cover. Do not use your fingernail as this could result in injury.

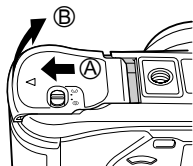

### 4 Insert the batteries, making sure that they are correctly oriented as shown in the illustration.

When using CR-V3 lithium battery packs

When using AA (R6) batteries

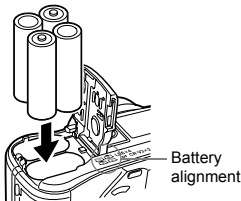
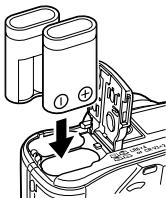

The correct way to insert the AA (R6) batteries is indicated on the bottom of the camera.

- When using rechargeable AA (R6) batteries, charge them before use.

**5 Close the battery compartment cover, then press it down **C** and slide it in the direction shown **D**.**

- Press the center of the cover, as it may be difficult to close properly by pressing the edge.
- Make sure the cover is closed securely.

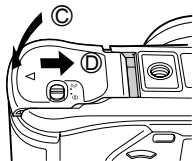

**6 Slide the battery compartment lock from **⊖** to **⊕**.**

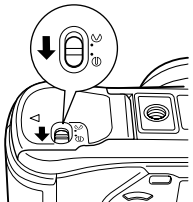

Note

- If the camera is left for about 1 hour with the batteries removed, some of the internal settings may revert to the factory default settings.

**Precautions when using batteries**

The amount of power consumed varies considerably depending on the operations performed on the digital camera. If you use exhausted batteries or alkaline batteries, the camera may turn off without displaying the battery level warning (P.15).

## Selecting optional batteries or an AC adapter

In addition to the batteries provided with the camera, the following types of battery or AC adapter can be used. Choose the power source best suited to the situation.

### ●CR-V3 lithium battery packs (Not rechargeable)

Since the CR-V3 lithium battery pack has a long service life, it is convenient when traveling.

### ●NiMH batteries (Rechargeable)

Olympus NiMH batteries are rechargeable and economical.

However, if the batteries are repeatedly recharged before they are completely exhausted, the working time will gradually be reduced.

### ●AA (R6) alkaline batteries

When you need batteries in a hurry, you can use AA (R6) alkaline batteries, which are easy to obtain anywhere. However, the number of pictures that you can take may vary considerably depending on the battery manufacturer, shooting conditions, etc. When taking pictures, use the viewfinder and turn off the monitor whenever possible to save power.

### ●AC adapter

An AC adapter is useful for time-consuming tasks such as image downloads. An optional Olympus CAMEDIA-brand AC adapter allows you to power your digital camera from a common AC wall outlet. Be sure to use the specified AC adapter.

Use an AC adapter designed to operate on the AC voltage in the area the camera is being used.

Consult your nearest Olympus dealer or Service center for details.

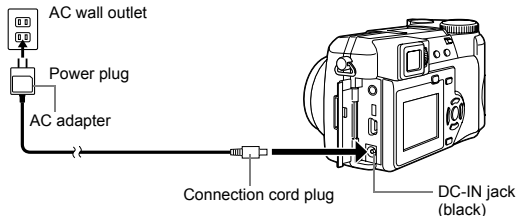



Note

- If the battery power runs out while the camera is connected to a PC, the image data may be lost or damaged. You are recommended to use the AC adapter when transferring images to a PC. Do not connect or disconnect the AC adapter while the camera is communicating with the PC.
- Do not remove or load the batteries or connect or disconnect the AC adapter while the camera is turned on. Doing so could affect the camera's internal settings or functions.
- The life of the batteries may vary according to the type of battery, manufacturer, shooting conditions, etc.
- Power is consumed continuously during the conditions described below. This could shorten the life of the batteries.
  - When the monitor is turned on.
  - When the monitor is in the playback mode for an extended period of time.
  - Repeated zoom adjustments.
  - Repeated auto-focus by depressing the shutter button halfway.
  - When the FULLTIME AF mode is turned on.
  - When the camera is connected to a PC.
- When using an AC adapter, power is supplied to the camera by the AC adapter even if batteries are loaded in the camera. The AC adapter does not charge batteries in the camera.
- Carefully read the AC adapter's instructions before use.

# Inserting a card

"Card" in this manual refers to the xD-Picture Card. The camera uses the card to record pictures.

## Card basics

The card corresponds to normal camera film for recording the pictures you have taken. Pictures recorded and stored on the card can easily be erased, overwritten, and/or edited on a PC.

### 1 Getting started

- ① Index area  
You can write down the card's contents.
- ② Contact area  
Comes into contact with the camera's signal read contacts.



### Compatible cards

- xD-Picture Card (16 – 256 MB)



Note

- This camera may not recognize a non-Olympus card or a card that was formatted on another device (such as a PC, etc.). Before use, be sure to format the card on this camera.  "CARD SETUP - Formatting Cards" (P.139)

## 1 Make sure the camera is turned off.

- The monitor is off.
- The viewfinder is off.
- The lens is not extended.

## 2 Open the card cover.

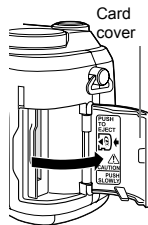

### 3 Insert the card in the appropriate direction.

- Insert the card while keeping it straight.
- The card will stop with a click when it is inserted all the way to the end.
- Inserting the card the wrong way or at an angle could damage the contact area or cause the card to jam.
- If the card is not inserted all the way, data may not be written to the card.

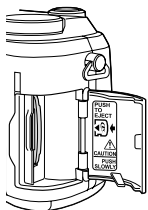
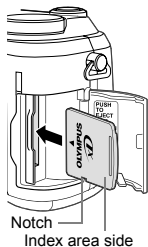

Card inserted correctly

### 4 Close the card cover securely until it clicks.

## Removing the card

### 1 Push the card all the way in to unlock it, then let it return slowly.

- The card is ejected a short way and then stops. Hold the card straight and pull it out.

#### Note

Releasing your finger quickly after pushing the card all the way in may cause it to eject forcefully out of the slot.

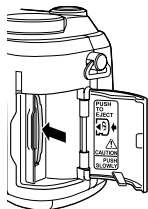

Note

- Do not press on the card with hard or pointed items such as ballpoint pens.
- Never open the card cover, or remove the card or the batteries while the camera is turned on. Doing so could destroy the data stored on the card. Once destroyed, data cannot be restored.



# Power on/off

- 1 Press the tabs on the lens cap as indicated by the arrows and remove the lens cap.

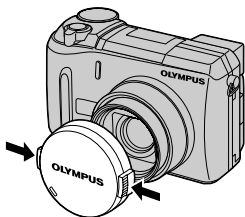

- 2 Press the power switch.

- The power turns on and the lens extends when the mode dial is set to any mode other than . The viewfinder turns on.
- When the mode dial is set to , the camera turns on in the playback mode and the monitor turns on.

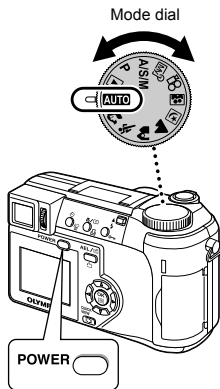

- 3 To turn the camera off, press the power switch again.



## TIPS

- To save battery power, the camera automatically enters the sleep mode and stops the operation after about 3 minutes of non-operation. The camera activates again as soon as you operate the shutter button or zoom lever. The sleep time interval can be set in any shooting mode (except ). "SLEEP - Sleep Timer" (P.144)

## Startup/Shutdown screen

You can register a picture that will be displayed on the monitor when turning the camera on or off. (P.146)

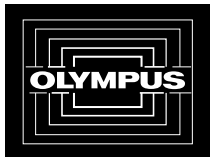

Startup/Shutdown screen  
(Factory default setting)

1

Getting started

## If the card is not recognized (card check)

When the power is turned on, the camera checks the card automatically. If there is no card in the camera or a card that is not supported by this camera is inserted, the following screen is displayed.



Note

- All data stored on the card is erased when the card is formatted.

Monitor indication	Corrective action
<p>The screen shows a warning icon (exclamation mark in a diamond) above the text "NO CARD".</p>	<p>There is no card in the camera or the card is not inserted properly.</p> <p>→ Insert a card. If a card is already inserted, remove it and insert it again correctly.</p>
<p>The top screen is titled "CARD SETUP" and has two buttons: "POWER OFF" and "FORMAT". The bottom screen is titled "FORMAT" and has a warning icon with the text "CAUTION ERASING ALL", and two buttons: "YES" and "NO". Both screens have "SELECT" and "GO OK" options at the bottom.</p>	<p>The card cannot record, play back or erase pictures. Format the card or replace it with a new one.</p> <p>→ Press   to select POWER OFF, then press . Replace the card with a new one.</p> <p>→ Format the card.</p> <p>Press   to select  FORMAT, then press  to display the confirmation screen. Select YES and press .</p> <p>Formatting starts. If the card was successfully formatted, the camera is ready to take pictures.</p>

# Selecting a language



You can select a language for on-screen display. This reference manual shows the English on-screen display in the illustrations and explanations. Available language vary depending on the area where you purchased this camera.

## 1 Getting started

- 1 Set the mode dial to **P** and press the power switch to turn the camera on.

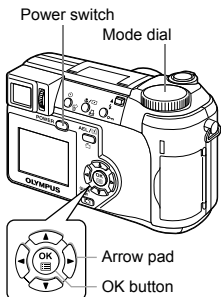

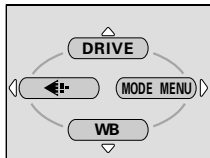

- 2 Press .
  - The top menu is displayed.
- 3 Press on the arrow pad to select **MODE MENU**.

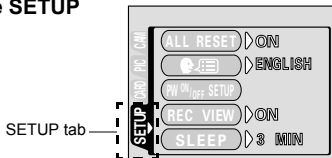

Top menu

- 4 Press to select the **SETUP** tab, then press .



- 5 Press   to select  , then press .

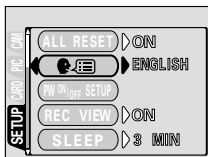

- 6 Press   to select a language, then press .

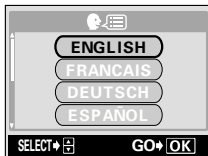

- 7 Press  again to exit the menu.
- 8 To turn the camera off, press the power switch.

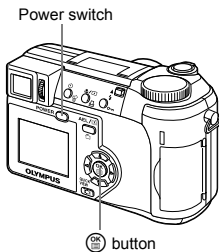

# Setting the date and time



- 1 Set the mode dial to **P** and press the power switch to turn the camera on.

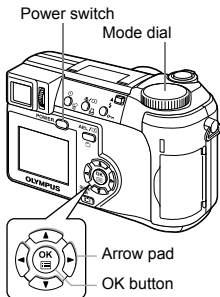

- 2 Press .
  - The top menu is displayed.
- 3 Press on the arrow pad to select **MODE MENU**.

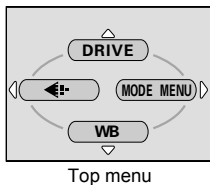

- 4 Press to select the **SETUP** tab, then press .

SETUP tab

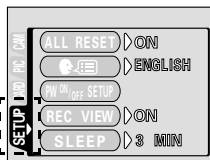

- 5 Press to select , then press .
- The green frame moves to the selected item.

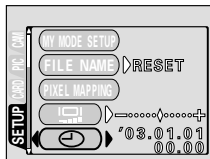

- 6** Press to select one of the following date formats: Y-M-D (Year/Month/Day), M-D-Y (Month/Day/Year), D-M-Y (Day/Month/Year). Then press .

- Move to the year setting.
- The following steps show the procedure used when the date and time settings are set to Y-M-D.

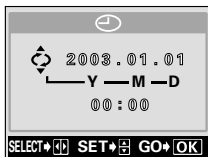

- 7** Press to set the year, then press to move to the month setting.

- To move back to the previous setting, press .
- The first two digits of the year are fixed.

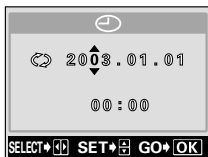

- 8** Repeat this procedure until the date and time are completely set.

- The time is displayed in the 24-hour format. Consequently, 2 p.m. is displayed as 14:00.

- 9** Press .

- For a more accurate setting, press when the time signal hits 00 seconds. The clock starts when you press the button.

- 10** To turn the camera off, press the power switch.

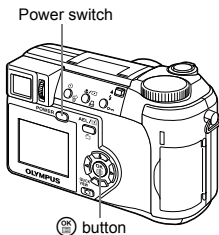

Note

- The current settings are retained even when the power is turned off, unless they are readjusted.
- The date and time settings will be canceled if the camera is left without batteries for approximately 1 hour. The settings will be canceled more quickly if the batteries were only loaded in the camera for a short time before being removed. Before taking important pictures, check that the date and time settings are correct.

# Adjusting the viewfinder

To make the camera easier to use, adjust the viewfinder to match the eyesight (visual acuity) of the person using the camera.

- 1 Set the mode dial to **AUTO** and press the power switch.**
  - The camera and the viewfinder turn on.

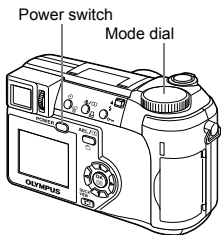

- 2 While looking through the viewfinder, slowly turn the diopter adjustment dial.**

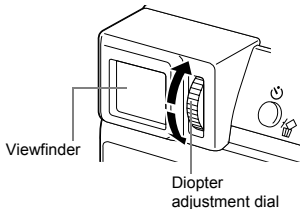

- 3 Turn the dial until the AF target mark can be seen clearly.**



AF target mark

# Holding the camera

Hold the camera firmly with both hands while keeping your elbows at your sides to prevent the camera from moving. When taking pictures in the vertical position, hold the camera so that the flash is higher than the lens. Keep your fingers and the strap away from the lens and flash.

Horizontal grip

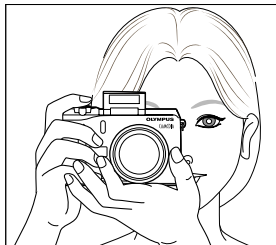

Vertical grip

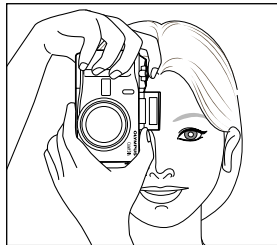

Top view

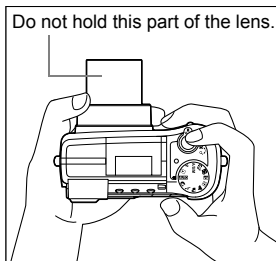

- Clear pictures cannot be obtained if the camera moves as the shutter button is pressed. Hold the camera correctly, and press the shutter button gently.



# 2 Using the menu

## About the menu

When you turn on the camera and press , the top menu is displayed on the monitor (or viewfinder). The functions of this camera are set from the menus. This chapter explains how the menus work, using the **P** mode screens.



The top menu is displayed.

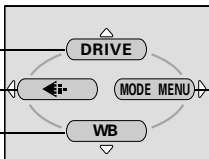

Press .

### Top menu





Use the arrow pad to select a menu.

### SHORTCUT MENU

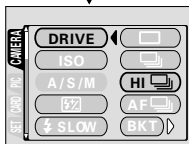
- Take you directly to the setting screens.
  - Display operational buttons at the bottom of the screen.
  - The functions registered in the shortcut menu can also be accessed from the MODE MENU.
  - The shortcut menu can be replaced in modes other than **AUTO**  .
-  "Setting the shortcut menu" (P.134)



### MODE MENU

- Lets you access the menu selections to set the ISO, sharpness, etc.
- Categorizes the settings into 4 tabs.
- Press   to select a tab and display the associated menu items.

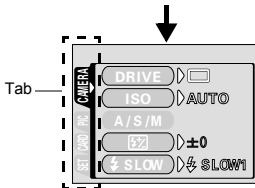

# How to use the menus

1 Press to display the top menu. Press .

2 Press to select a tab, then press .

## Top menu

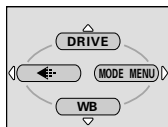

## CAMERA tab

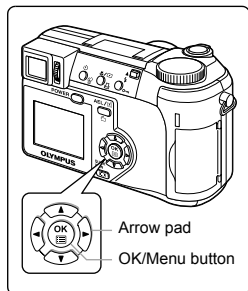
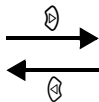
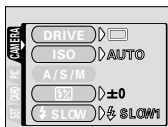

## PICTURE tab



Press to return to the tab selection screen.

## CARD tab



## SETUP tab



2

Using the menus

continued overleaf.

3 Press to select an item, then press .

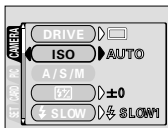
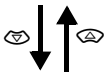
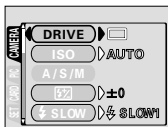

The green frame moves to the selected item.

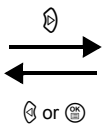

To return to select an item, press or .

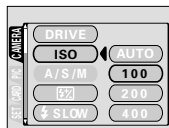
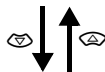
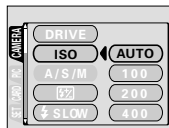

4 Press to select a setting. Press to complete setting. Press again to exit the menu and return to shooting status.



Note

- Not all items can be selected depending on the status of the camera and the settings performed.
- In the shooting modes, you can take pictures by pressing the shutter button even when menus are displayed.
- If you want to save the settings after the camera is turned off, set ALL RESET to OFF. "ALL RESET – Saving the camera's settings" (P.128)

# Shortcut menu

## ● Shooting modes

**AUTO** mode



**WB** mode

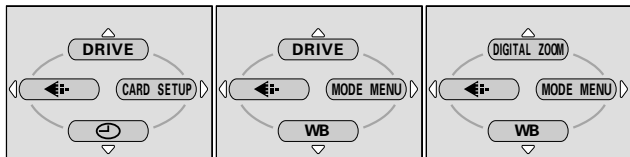

(Factory default setting)

### DRIVE

Selects a shooting mode from (single-frame shooting), (sequential shooting), **HI** (high speed sequential shooting), **AF** (AF sequential shooting) and BKT (auto bracketing).

P.83

### DIGITAL ZOOM

Extends the maximum optical zoom, making possible up to approx. 30x zoom.

P.54



Sets the image quality and resolution.  
Still picture : TIFF, SHQ, HQ, SQ1, SQ2  
Movie : HQ, SQ

P.91

### WB

Sets the appropriate white balance according to the light source.

P.98



Sets the date and time.

P.28

### CARD SETUP

Formats a card.

P.139

2

Using the menus

## ● Playback mode

Still picture

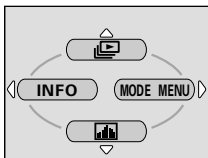

Movie

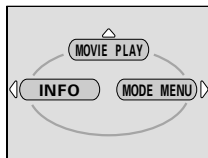

2

Using the menus



Runs through all saved pictures one after another.

P.113

### MOVIE PLAY

MOVIE  
PLAYBACK

Plays back movies.

P.114

INDEX

Creates an index picture of a movie in 9 frames.

P.116

EDIT

Edits a movie.

P.118

### INFO

Displays all the shooting information on the monitor.

P.141



Displays a histogram showing the luminance distribution of still pictures.

P.106



### TIPS

- The functions registered in the shortcut menus can also be accessed from the MODE MENU. The shortcut menu can be replaced in modes other than **AUTO** .   
 "Setting the shortcut menu" (P.134)



# Mode Menu

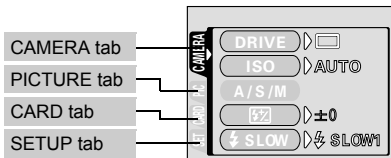

The MODE MENU has 4 tabs. Press to select a tab and display the associated menu items.

## ● Shooting modes







CAMERA tab		
DRIVE	Selects a shooting mode from  (single-frame shooting),  (sequential shooting), <b>HI</b> (high speed sequential shooting), <b>AF</b> (AF sequential shooting) and BKT (auto bracketing).	P.83
ISO	Selects the ISO sensitivity from AUTO, 100, 200 and 400.	P.96
A/S/M	Selects the shooting mode from A (Aperture priority shooting), S (Shutter priority shooting) and M (Manual shooting).	P.63
1/2/3/4	Selects a mode to be activated when taking pictures in  mode.	P.67
	Adjusts the amount of light emitted by the flash.	P.62
SLOW	Selects from  SLOW1 (1st curtain),   SLOW1 (1st curtain with red-eye reduction) and  SLOW2 (2nd curtain) when the flash mode is set to  SLOW (slow synchronization).	P.61
NOISE REDUCTION	Reduces the noise that affects pictures during long exposures.	P.105
MULTI METERING	Meters the brightness of the subject at up to 8 different points to set the optimal exposure based on the average brightness.	P.76

DIGITAL ZOOM	Extends the maximum optical zoom, making possible up to approx. 30x zoom.	P.54
FULLTIME AF	Keeps the image in focus at all times without having to press the shutter button halfway.	P.69
AF MODE	Selects the auto focus method (iESP or SPOT).	P.68
	Allows pictures to be taken as close as 3 cm/1.2" from the subject.	P.81
PANORAMA	Allows panorama pictures to be taken with Olympus CAMEDIA-brand cards.	P.86
2 IN 1	Combines two still pictures taken in succession and stores them as a single picture.	P.88
FUNCTION	Adds special effects to pictures (BLACK & WHITE, SEPIA, WHITE BOARD, BLACK BOARD).	P.90
AF AREA	Changes the position of the AF target mark using the arrow pad.	P.70
INFO	Selects whether to display all the information such as shutter speed and white balance, or only the minimum information.	P.141
	Displays a histogram showing the luminance distribution of still pictures.	P.106

PICTURE tab		
	Sets the image quality and resolution. Still picture: TIFF, SHQ, HQ, SQ1, SQ2 Movie : HQ, SQ	P.91
WB	Sets the appropriate white balance according to the light source.	P.98
	Makes fine changes to the white balance.	P.101
SHARPNESS	Adjusts the sharpness of the image.	P.102
CONTRAST	Adjusts the contrast of the image.	P.103
SATURATION	Adjusts the level of color depth without changing the tint.	P.104

CARD tab		
CARD SETUP	Formats a card.	P.139



SETUP tab		
ALL RESET	Selects whether to keep the current camera settings when you turn off the power.	P.128
	Selects a language for on-screen display.	P.26
PW ON/OFF SETUP	Sets the picture displayed on the monitor when the power is turned on and off.	P.146
REC VIEW	Selects whether to display pictures on the monitor while saving them to a card.	P.143
SLEEP	Sets the sleep timer.	P.144
MY MODE SETUP	Customizes settings which are activated in the  mode.	P.136
FILE NAME	Changes how file names are assigned.	P.148
PIXEL MAPPING	Checks the CCD and image processing functions for errors.	P.149
	Adjusts the brightness of the monitor or viewfinder.	P.142
	Sets the date and time.	P.28
m/ft	Sets the measurement unit (m/ft) used during manual focus.	P.150
VIDEO OUT	Selects NTSC or PAL according to your TV's video signal type. TV video signal types differ depending on the region.	P.151
SHORT CUT	Assigns frequently used functions as shortcut menus.	P.133
CUSTOM BUTTON	Assigns a frequently used function to the camera's custom button.	P.130
	Turns the beep sound used for button operations and warnings on and off.	P.145

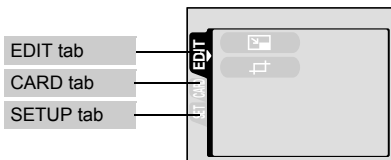

## ●Playback mode





## 2



EDIT tab*1		
	Makes the file size smaller and saves it as a new file.	P.122
	Crops part of a picture and saves it as a new file.	P.123

\*1 The EDIT tab is not displayed during movie playback.

CARD tab		
CARD SETUP	Erases all image data stored on the card or format the card.	P.127, 139

SETUP tab		
ALL RESET	Selects whether to keep the current camera settings when you turn off the power.	P.128
	Selects a language for on-screen display.	P.26
PW ON/OFF SETUP	Sets the picture displayed on the monitor when the power is turned on and off.	P.146
SCREEN SETUP	Registers a stored picture for use as the picture displayed when the power is turned on and off.	P.147
	Adjusts the brightness of the monitor.	P.142
	Sets the date and time.	P.28
VIDEO OUT	Selects NTSC or PAL according to your TV's video signal type. TV video signal types differ depending on the region.	P.151

---

	Selects the number of frames in the index display.	P.112
	Turns the beep sound used for button operations and warnings on and off.	P.145

# 3 Shooting basics

## Shooting modes

The shooting modes include modes where the optimal settings for the situation are automatically selected, and modes where you can select the settings best suited to the shooting conditions and the effect you wish to achieve.

You can change the shooting mode before and after turning the camera on.

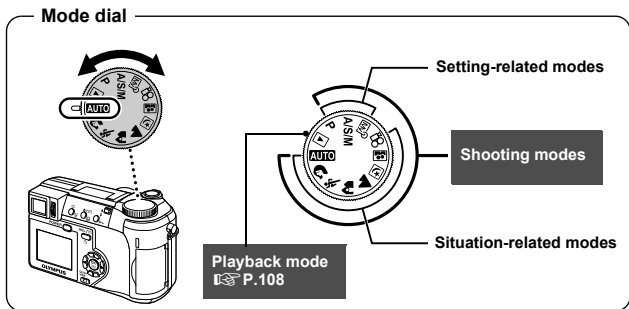

3

Shooting basics

## Situation-related modes

### **AUTO** Full-auto shooting

Allows you to take still pictures using no special functions or manual adjustments. The camera sets the optimal focusing and exposure. This is the simplest of all shooting modes.

### **Portrait** shooting

Suitable for taking a portrait-style shot of a person. This mode features an in-focus subject against a blurred background. The camera automatically sets the optimal shooting conditions.

### **Sports** shooting

Suitable for capturing fast-moving action (such as sports) without blur. Even a fast-moving subject will be clear and sharp, as if it is not moving, enabling

you to capture facial expressions and detailed activity. The camera automatically sets the optimal shooting conditions.

### Landscape+Portrait shooting

Suitable for taking pictures of both your subject and the landscape. The picture is taken with the background as well as the subject in the foreground in focus. You can take pictures of your subject against a beautiful sky or landscape. The camera automatically sets the optimal shooting conditions.

### Landscape shooting

Suitable for taking pictures of landscapes and other outdoor scenes. Both the foreground and the background are in focus. Since blues and greens are vividly reproduced in this mode, it is excellent for shooting natural scenery. The camera automatically sets the optimal shooting conditions.

### Night Scene shooting

Suitable for shooting pictures in the evening or at night. The camera sets a slower shutter speed than is used in normal shooting. For example, if you take a picture of a street at night in **AUTO** mode, the lack of brightness will result in a dark picture with the background underexposed and without details. In the Night Scene shooting mode, the true appearance of the street is captured. The camera automatically selects the optimal settings for this type of shooting condition. Since the shutter speed is slow, make sure you stabilize the camera by using a tripod.



### Self-Portrait shooting

Enables you to take a picture of yourself while holding the camera. Point the lens towards yourself and the focus will be locked on you. The camera automatically sets the optimal shooting conditions. The zoom is fixed in the wide position and cannot be changed.

## Setting-related modes

### P Program shooting

Allows you to take still pictures. The camera sets the aperture and shutter speed. Other functions, such as flash modes and drive modes, can be adjusted manually.

### A/S/M Aperture priority/Shutter priority/Manual shooting

When the mode dial is set to **A/S/M**, the following items can be set with the menus.  "A/S/M mode" (P.63).

## 3

### A Aperture priority shooting

Allows you to set the aperture manually. The camera sets the shutter speed automatically. By decreasing the aperture value (F-number), the camera will focus within a smaller range, producing a picture with a blurred background. Increasing the value forces the camera to focus over a wider range in the forward and backward directions, resulting in increased "depth of field", in which both the subject and the background are in focus.

 "Aperture priority shooting" (P.64)



Aperture (F-number) is decreased.



Aperture (F-number) is increased.

### S Shutter priority shooting

Allows you to set the shutter speed manually. The camera sets the aperture automatically. Set the shutter speed according to the subject and the type of effect you want.

 "Shutter priority shooting" (P.65)



Setting the shutter speed higher lets you capture fast-moving action without blur. The subject will be clear and sharp, as if it is not moving.



Setting the shutter speed lower blurs a moving subject, giving the impression of movement.

## M Manual shooting

Allows you to set the aperture and shutter speed manually. To check the exposure, refer to the exposure differential. This mode gives you more creative control, allowing you to make the settings you need to get the type of picture you want, regardless of optimum exposure.

"Manual shooting" (P.66)

## My Mode

Allows you to save your favorite settings as your own personal mode and use these customized settings when taking pictures. Current settings can also be saved for retrieving by this mode. "MY MODE SETUP" (P.136)

"Using My Mode" (P.67)

## Movie record

Allows you to record movies. The camera sets the aperture and shutter speed automatically. Even if the subject moves during recording or the distance to the subject changes, correct focusing and exposure are maintained continuously. The sound cannot be recorded.

"Recording movies" (P.51)



Note

- The available settings vary depending on the mode. "Modes and Shooting Functions" (P.180)

# Taking still pictures

You can take still pictures using either the viewfinder or the monitor.

Mode dial



- 1 Set the mode dial to **AUTO** **A/S/M P** and press the power switch.

"Power on/off" (P.24)

- The viewfinder turns on.

To shoot using the monitor, press to turn the monitor on.

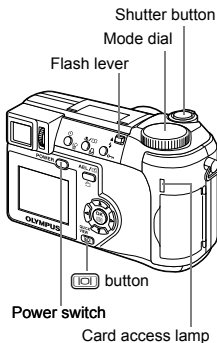

- 2 Decide the composition of the picture.





AF target mark

3

Shooting basics

### 3 Press the shutter button gently (halfway) to adjust the focus.

- When the focus and exposure are locked, the green lamp lights (focus lock).
- The AF target mark moves to the focused position.
- The shutter speed and aperture value automatically set by the camera are displayed (except in **M** mode).
-  blinks to warn of camera movement. Push the flash lever up to make the flash pop up. (P.55)
- When  lights after the flash has popped up, the flash is ready to fire. The flash fires automatically when the shutter button is pressed all the way.



 mark  
Green lamp

### 4 Press the shutter button all the way (fully).

- The camera takes the picture.
- The card access lamp blinks while the picture is stored on the card.



#### TIPS

**The subject cannot be focused on.**

 "If correct focus cannot be obtained" (P.49)

**The green lamp blinks.**

→ You are too close to the subject. Take the picture at least 7 cm/2.8" (wide-angle) (1.2 m/3.9 ft. (telephoto)) away from the subject. If you use the super macro mode, you can take pictures as close as 3 cm/1.2" from the subject. (P.81)

→ Depending on the subject, the focus and exposure may not be locked.  "Subjects that are difficult to focus on" (P.50)

** blinks when the shutter button is pressed halfway.**

→ The flash is charging. Wait until the lamp goes off.

**To check the picture you have just taken immediately**

→ Set REC VIEW to ON.  "REC VIEW" (P.143)



**The viewfinder or monitor turns off automatically**

→ If the camera is not used for over 3 minutes, the viewfinder and monitor turn off automatically. Operate the shutter button or zoom lever to turn the viewfinder or monitor on.  "SLEEP - Sleep Timer" (P.144)



**To adjust the brightness of the viewfinder or monitor**

→ Go to "Monitor brightness Adjustment" and adjust the brightness.  "Monitor/viewfinder brightness adjustment" (P.142)

**The viewfinder or monitor is hard to see**

→ Bright light, such as direct sunlight, may cause vertical lines (smears) to appear on the image in the viewfinder or monitor. This does not affect recorded pictures.

**To check the area the camera is focusing on**

→ If you press  while pressing the shutter button halfway, the area you are focusing on is enlarged. Pressing  once more returns the size to normal. This function is not available in the digital zoom range.



 "DIGITAL ZOOM - Using the digital zoom" (P.54)



Note

- Press the shutter button gently using the ball of your finger. If it is pressed hard, the camera may move and pictures may come out blurred.
- Recorded pictures will be saved on the card regardless of whether the camera is turned off or the batteries are replaced or removed.
- Never open the card cover, remove the batteries or disconnect the AC adapter while the card access lamp is blinking. Doing so could destroy stored pictures and prevent storage of pictures you have just taken.
- When taking pictures against strong backlight, the area of the picture in shadow may appear colored.

# If correct focus cannot be obtained

When the subject cannot be focused on, you can focus the camera on another point at roughly the same distance (focus lock) and take the picture as explained below.

## Using the Focus Lock function

Mode dial



### 1 Position the AF target mark on the subject you want to focus on.

- When shooting a hard-to-focus subject or a fast-moving subject, point the camera at an object at the same distance away as the subject.

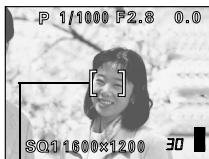

AF target mark

### 2 Press the shutter button halfway until the green lamp lights.

- When the focus and exposure are locked, the green lamp lights.
- The AF target mark moves to the focused position.
- When the green lamp blinks, the focus and exposure are not locked. Release your finger from the shutter button, re-position your subject and press the shutter button halfway again.

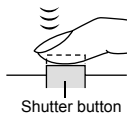

Shutter button

### 3 Keeping the shutter button pressed halfway, recompose your shot.



3

Shooting basics

## 4 Press the shutter button fully.

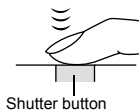

**TIPS** - - - - -  
The frame in which you focus on a subject is different from the frame in which you lock the exposure.

☞ “AE LOCK - Locking the exposure” (P.78)

**Fix the focus position.**

☞ “AF LOCK - Locking the focus” (P.71)

**Focus on the subject in the center of the frame.**

☞ “AF MODE - Changing the focus range” (P.68)

### 3

## Subjects that are difficult to focus on

Under certain types of conditions, the auto focus may not work properly. If this happens, focus on an object with high contrast at the same distance as the intended subject (focus lock), recompose your shot and then take the picture. If the subject has no vertical lines, hold the camera vertically and focus the camera using the focus lock function by pressing the shutter button halfway, then return the camera to the horizontal position while keeping the button pressed halfway and take the picture.

If the subject still cannot be focused on, use the manual focus. ☞ “Manual focus” (P.73)

The green lamp blinks.  
The subject cannot be brought into focus.



Subject with low contrast



Subject with an extremely bright area in the center of the frame

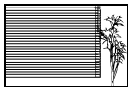

Subject without vertical lines

The green lamp lights, but the subject cannot be brought into focus.



Subjects at different distances

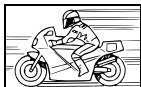

Fast-moving subject



The subject to be focused on is not in the center of the frame.

# Recording movies



This function allows you to record movies. Even if the subject moves during recording or the distance to the subject changes, correct focusing and exposure are maintained continuously. The sound cannot be recorded.

## Mode dial



### 1 Set the mode dial to and press the power switch.

 "Power on/off" (P.24)

- The viewfinder turns on.
- The available recording time on the card that you are using is displayed.

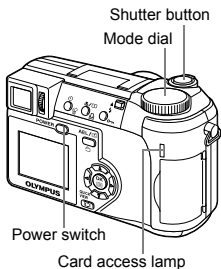

### 2 Decide the composition of the picture.



### 3 Press the shutter button fully to start recording.

- The card access lamp blinks while the movie is stored on the card.
- During movie recording,  lights red.





Seconds remaining

### 4 Press the shutter button again to stop recording.

- When the remaining recording time has been used up, recording stops automatically.
- When there is space in the card memory, the remaining recording time is displayed, and the camera is ready to shoot.



Note

- Depending on the card, the remaining recording time may drop rapidly during recording. Try using the card again after formatting it with your camera.  "CARD SETUP - Formatting Cards" (P.139)
- If FULLTIME AF is set to OFF, the focus is locked when the shutter button is pressed in step 3, causing the focus of some pictures to be compromised.
- In  mode, the flash and manual focus (MF) cannot be used.

**Notes for recording movies over a long time**

- Recording will continue until the card is full unless stopped by pressing the shutter button.
- A long recorded movie cannot be edited. (P.116)
- If a single movie recording uses up all of the card's memory, create space on the card by deleting the movie or downloading it to a PC.

# Zoom

Telephoto and wide-angle shooting are possible at 10x magnification (the optical zoom limit, equivalent to 38 mm – 380 mm on a 35 mm camera). By combining the optical zoom with the digital zoom, zoom magnification can be increased to a maximum of approximately 30x.

Camera movement is likely to occur at higher magnifications. Stabilize the camera with a tripod, etc. to avoid camera movement.

## Using the optical zoom



- 1 Push or pull the zoom lever.

Zoom lever

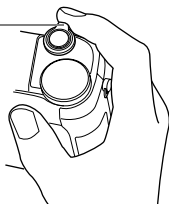

Wide-angle:

Push the zoom lever toward W to zoom out.



Telephoto:

Pull the zoom lever toward T to zoom in.





## DIGITAL ZOOM - Using the digital zoom

Disco de modo



- 1 In the top menu, select **MODE MENU** → **CAMERA** → **DIGITAL ZOOM** → **ON**, and press .

 “How to use the menus” (P.33)

- Press  again to exit the menu.

Zoom lever

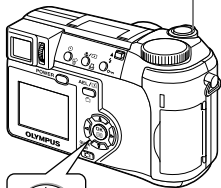

Mode dial



In the top menu, select **DIGITAL ZOOM** → **ON**, and press .

- 2 Pull the zoom lever toward **T**.

- The white area of the zoom indicator indicates the optical zoom. If the digital zoom is set to ON, a red area appears on the zoom indicator. When you reach the limit of the optical zoom, the digital zoom is enabled.



The cursor moves up and down on the zoom indicator according to the zoom magnification.  
The cursor turns orange when inside the digital zoom field.



- Pictures taken with the digital zoom may appear grainy.

# 4 Flash

## Flash shooting



Select the flash mode best suited to the light conditions and the effect you want to achieve. You can also adjust the amount of light emitted using the flash intensity control.

Mode dial



### 1 Push the flash lever up. (①)

- The flash pops up. (②)

### 2 Set the flash mode by repeatedly pressing ⚡.

- The flash mode changes in the sequence shown below (when all modes are available).

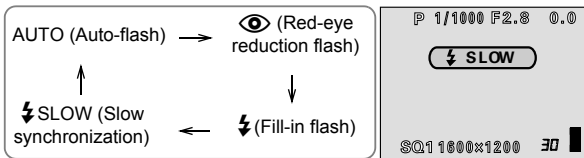
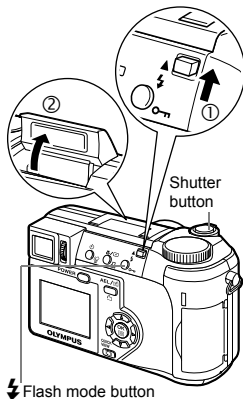

- If no operation is performed for about 3 seconds, the flash mode is set and the mode selector screen is automatically exited.
- To prevent the flash from firing, press down on the top of the flash to retract it.



### 3 Press the shutter button halfway.

- In conditions where the flash will fire, ⚡ lights.

### 4 Press the shutter button fully to take the picture.



#### Flash working range

W (max.): Approx. 0.3 m to 4.5 m (1.0 ft. to 14.8 ft.)

T (max.): Approx. 1.2 m to 3.5 m (3.9 ft. to 11.5 ft.)

#### Function restrictions according to mode

Flash mode	Mode					A/S/M			P
	AUTO				MY*	A	S	M	
Auto	✓	✓	✓	✓	✓	—	—	✓	
	✓	✓	✓	✓	✓	—	—	✓	
⚡	—	✓	✓	✓	✓	—	—	✓	
⚡ SLOW1	—	✓	✓	✓	✓	✓	—	✓	
⚡ SLOW2	—	✓	✓	✓	✓	✓	✓	✓	
⚡ SLOW1	—	✓	✓	✓	✓	—	—	✓	
	✓	✓	✓	✓	✓	✓	—	✓	

✓: Available, —: Not available, : Factory default setting

\* The factory default settings and available modes vary depending on the selected mode.

**TIPS**

The ⚡ (flash standby) indication blinks.

→ The flash is charging. Wait until ⚡ goes off.

**Camera movement warning (Auto-flash, red-eye reduction flash, fill-in flash)**

→ When ⚡ (camera movement warning) lights, the shutter speed locks at its current level. This helps prevent camera shake problems (shutter speeds that are too slow can cause blur). However, if the zoom magnification is increased, the camera will increase the locked shutter speed accordingly.

Zoom position	Shutter speed
W (max.)	1/30 sec.
T (max.)	1/250 sec.



Note

- The flash does not fire in the following situations:  
In the movie record mode, during auto bracketing, during super-macro shooting, when FUNCTION is set to WHITE BOARD/BLACK BOARD, and during Panorama shooting
- The flash may not give you the optimum result in macro mode, especially with wide-angle shooting. Check the resulting picture on the monitor.
- If a conversion lens is attached to the camera, do not use the flash.

**●Auto-flash (No indication)**

The flash fires automatically in low light or backlight conditions. To shoot a subject with backlight, position the AF target mark over the subject.

**●Red-eye reduction flash (👁)**

The light from the flash may make the subject's eyes appear red in the picture. The red-eye reduction flash mode significantly reduces this phenomenon by emitting pre-flashes before firing the regular flash. This helps accustom the subject's eyes to the bright light and minimizes the red-eye phenomenon.



The subject's eyes appear red.



Note

- After the pre-flashes, it takes about 1 second before the shutter is released. Hold the camera firmly to avoid camera movement.
- Effectiveness may be limited if the subject is not looking directly at the pre-flashes, or if the shooting range is too far. Individual physical characteristics may also limit effectiveness.

**●Fill-in flash (⚡)**

The flash fires regardless of the available light. This mode is useful for eliminating shadows on the subject's face (such as shadows from tree leaves), in a backlight situation, or for correcting the color shift produced by artificial lighting (especially fluorescent light).



Note

- The fill-in flash may not have the desired effect under excessively bright light.

## ●Flash off (🚫)

The flash does not fire even in low light conditions. Use this mode in situations where flash photography is not desired or is prohibited, such as in an art museum. You can also use this mode when you want to shoot a natural-looking twilight or night scene.



Note

- Since a slow shutter speed is automatically selected in low light situations when in the flash off mode, the use of a tripod is recommended to prevent your pictures from being blurred by camera movement.

## ●Slow Synchronization (⚡SLOW1 ⚡SLOW2 👁️⚡SLOW)

The slow synchronization flash is designed for slow shutter speeds. Normally, when shooting with a flash, shutter speeds cannot go below a certain level to prevent camera movement. But when shooting a night scene background, fast shutter speeds can make the background too dark. Slow synchronization flash allows both a slow shutter speed for the background and a flash for the subject. Since the shutter speed is slow, make sure you stabilize the camera by using a tripod. Otherwise, camera movement may cause the picture to be blurred.



### 1st curtain (front curtain) ⚡SLOW1

Usually, regardless of the shutter speed, the flash fires right after the shutter fully opens. This is called 1st curtain. Unless you change it, this is how the flash always fires. The slow synchronization factory default setting is ⚡SLOW1.

## 2nd curtain (rear curtain) ⚡ SLOW2

With 2nd curtain, the flash fires just before the shutter closes. Changing the flash timing can create interesting effects in your picture, such as expressing the movement of a car by showing the tail-lights streaming backwards. The slower the shutter speed, the better the effects turn out.

The slowest possible shutter speed depends on the shooting mode:

**M** mode : 16 sec.

**P, A, S, [ ]** mode : 4 sec.

When the shutter speed is set to 4 sec.

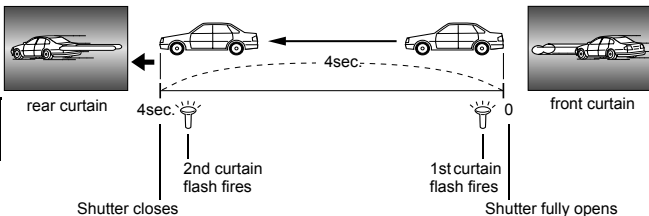

4

Flash







## 1st curtain with red-eye reduction 👁 ⚡ SLOW1

This mode is for when you want to use slow synchronization, yet also reduce the red-eye phenomenon. For instance, when shooting a person against a brightly lit night background. A normal flash might make the person's eyes red, but 1st curtain with red-eye reduction lets you capture the background correctly and reduce the red-eye phenomenon at the same time. 2nd curtain with red-eye reduction is not available.

# Using the slow synchronization flash SLOW

Mode dial



- 1 In the top menu, select **MODE MENU** → **CAMERA** →  **SLOW** →  **SLOW1**,   **SLOW**,  **SLOW2**, and press .

 "How to use the menus" (P.33)

- Press  again to exit the menu.

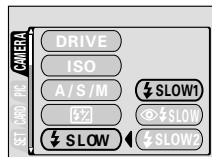
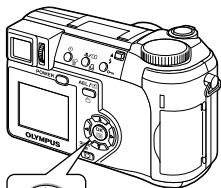

4

Flash

# Flash intensity control



You can adjust the amount of light emitted by the flash.

In some situations, you may get better results by adjusting the light emission. Examples include small subjects, distant backgrounds, or situations when increased contrast is desired. You can adjust the exposure in the range of  $\pm 2.0$  in  $1/3$  EV steps.

Mode dial



- 1 In the top menu, select **MODE MENU** → **CAMERA** → , and press .

☞ “How to use the menus” (P.33)

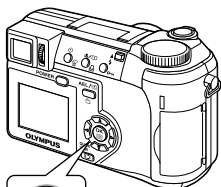

- 2 Press or to select a setting.

: Light emission is increased by  $1/3$ EV each time you press the button. (EV : Exposure Value)

: Light emission is decreased by  $1/3$  EV each time you press the button.

- Press again to exit the menu.

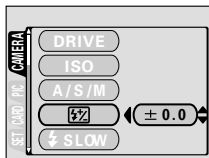

Note

- The flash adjustment effect may not be sufficient if the shutter speed is too fast.

# 5 Advanced shooting

## A/S/M mode

**A/S/M**

Select the shooting mode to be used when the mode dial is set to **A/S/M**.

**Mode dial****A/S/M**

- 1 In the top menu, select **MODE MENU** → **CAMERA** → **A/S/M** → **A**, **S** or **M**, and press .

 "How to use the menu" (P.33)

- Press  again to exit the menu.

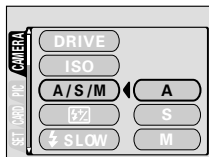
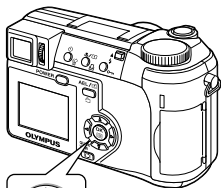
**5**

Advanced shooting



Mode dial

A/S/M

## 1 Select A mode.

☞ "A/S/M mode" (P.63)

## 2 Press to set the aperture value.

 : The aperture value increases.

 : The aperture value decreases.





If the aperture value is displayed in red, the aperture setting is unsuitable for the conditions. Take the following steps. (When the aperture value is displayed in green, the setting will provide optimum exposure.)

# 5

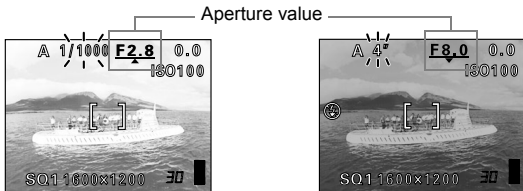
Advanced shooting



▲ appears: The image is overexposed.  
Press  to increase the aperture value.

▼ appears: The image is underexposed.  
Press  to decrease the aperture value.

Aperture range : Toward W : f2.8 to f8.0

Toward T : f3.7 to f8.0



- When the flash is set to the auto-flash mode, the shutter speed is fixed at 1/30 sec. in the maximum wide angle, or 1/250 sec. in the maximum telephoto, and will not go slower.

Mode dial

A/S/M

## 1 Select S mode.

"A/S/M mode" (P.63)

## 2 Press to set the shutter speed.

: Sets a faster shutter speed.

: Sets a slower shutter speed.

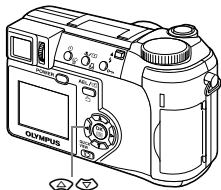

If the shutter speed is displayed in red, the setting is unsuitable for the conditions. Take the following steps. (When the shutter speed is displayed in green, the setting will provide optimum exposure.)

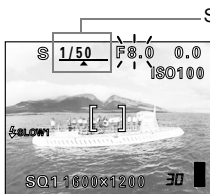

appears: The image is overexposed.  
Press to set a faster shutter speed.

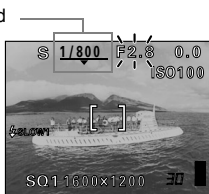

appears: The image is underexposed.  
Press to set a slower shutter speed.

Shutter speed range : 1 to 1/1000 sec.



• Shutter speeds that can be set differ according to the flash setting.

Note

Mode dial

A/S/M

## 1 Select M mode.

"A/S/M mode" (P.63)

## 2 Use the arrow pad to set the aperture value and shutter speed.

- : The aperture value increases.
- : The aperture value decreases.
- : Sets a faster shutter speed.
- : Sets a slower shutter speed.

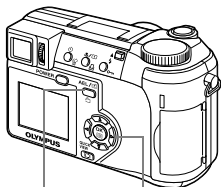

AEL /   
AE Lock/  
Custom button

Arrow pad

- When the shutter button is halfway pressed, the difference (ranging from -3.0 to +3.0 EV) between the exposure determined by the currently selected aperture and shutter speed compared to the exposure level considered optimal by the camera is displayed.
- If the exposure differential appears in red, it indicates that the exposure differential is less than -3.0 EV or more than +3.0 EV.
- When you press **AEL** / , the screen on the right appears with the bar indicating current exposure settings.

Exposure differential



Aperture value: f2.8 to f8.0 (W)

f3.7 to f8.0 (T)

Shutter speed : 16 to 1/1000 sec.



Note

- To avoid camera movement, you are recommended to use a tripod when taking pictures requiring a slow shutter speed.

When you use mode, the settings you selected with the menus in My Mode are activated.

Saving the shooting mode or function settings you want to use in advance lets you shoot with your favorite settings straightaway. You can also save the settings you are currently using. You can create and save up to 4 different patterns. “MY MODE SETUP” (P.136)

## Mode dial



- 1 In the top menu, select **MODE MENU** → **CAMERA** → **MY MODE** → **MY MODE 1** to **MY MODE 4**, and press .

“How to use the menus” (P.33)

- Press again to exit the menu.
- Only the settings in MY MODE 1 have already been saved. You cannot select MY MODE 2 to MY MODE 4 if no settings have been saved in them.

“MY MODE SETUP” (P.136)

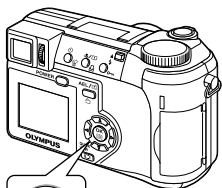

Arrow pad

OK button



Note

- Although the settings you are using can be saved, the saved zoom position may not be the same as the one being used.

# Focusing applications

## AF MODE - Changing the focus range

This function allows you to select the focus range of your subject.

- iESP** Focus selection is based on the entire picture on the screen. Even when the subject is not in the center of the screen, focusing is possible.
- SPOT** Focus selection is based on the subject within the AF target mark.

Mode dial



- 1 In the top menu, select **MODE MENU** → **CAMERA** → **AF MODE** → **iESP** or **SPOT**, and press

➡ "How to use the menu" (P.33)

- Press again to exit the menu.

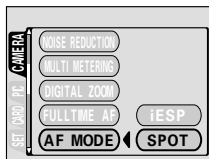
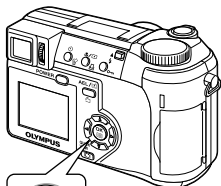

- In **AUTO** and mode, the AF MODE is fixed at iESP and cannot be changed.

Note

5

Advanced shooting

## FULLTIME AF - A reliable time-saving way to focus

FULLTIME AF keeps the subject in front of the lens in focus at all times, without having to press the shutter button halfway. When ON is selected, the focusing time is reduced, letting you take successive snapshots.



- In the top menu, select **MODE MENU** → **CAMERA** → **FULLTIME AF** → **ON**, and press .

"How to use the menus" (P.33)

- Press again to exit the menu.

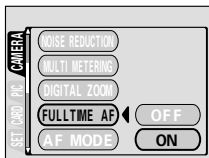
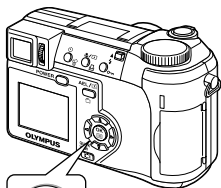

- Battery life is reduced when FULLTIME AF is used.

## AF AREA – Changing the position of the AF target mark

You can select the area you want to focus on by changing the position of the AF target mark.

Mode dial



### 1 Set the AF mode to SPOT.

☞ “AF MODE - Changing the focus range” (P.68)

### 2 In the top menu, select MODE MENU → CAMERA → AF AREA, and press .

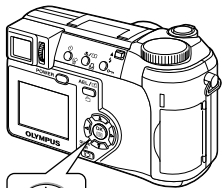

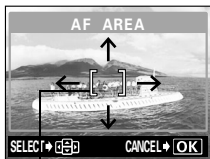

### 3 Use the arrow pad to move the AF target mark to the area you want to focus on.

- The AF target mark at the center of the screen can be moved vertically or horizontally.



AF target mark

### 4 Take the picture.

- To restore the AF target mark to its original position (at the center), press .
- Press  again to exit AF target mark selection mode.



Note

- AF AREA is not available when the digital zoom is set to ON.
- The location of the AF target mark cannot be saved.

## AF LOCK – Locking the focus

Registering the AF lock function on the **AEL** /  in advance enables easy locking of the focus.

Mode dial



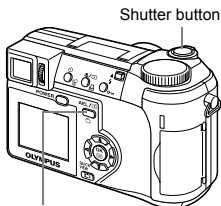

### 1 Register the AF lock function on **AEL** / .

 "Setting the custom button" (P.131)



### 2 Position the AF target mark on the subject you want to focus on and press **AEL** / .

- The focus is locked and the AF lock mark is displayed.
- To reset the AF lock, press **AEL** /  again to cancel the AF lock. Each time you press **AEL** / , AF lock is alternately engaged and canceled.

When **AEL** /  is pressed





When focus is locked



### 3 Press the shutter button fully.



**TIPS****How to save the locked focus after shooting (AF memory)**

- Hold down **AEL** /  for more than 1 second. The AF memory mark appears. When the mark appears, the locked focus is memorized. To cancel AF memory, press **AEL** /  again.

AF memory mark

**AF lock was canceled.**

- Do not operate any of the buttons or the mode dial after performing AF lock. AF lock will be canceled.
- The camera had emerged from sleep mode or the power was turned off.



Note

- AF lock is not available when a menu is displayed on the screen. Exit the menu.  "How to use the menus" (P.33)

## Manual focus

If auto focus is unable to focus on a subject, use manual focus.

Mode dial



- 1 Hold down for more than 1 second. When the focus distance selection screen appears on the monitor, press to select MF.

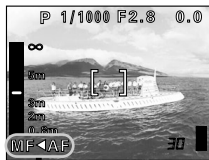
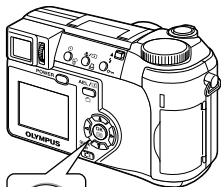

MF < AF



- 2 Press to set the focus distance.

- During operation, the area you are focusing on is enlarged. This lets you check whether the focus is in the right position.
- The distance indicator on the left of the monitor is for reference only.
- When the indicator is moved to less than 2 m (6.6 ft.), the display automatically switches to the 7 cm (2.8") to 2 m (6.6 ft.) display.

- 3 Hold down for more than 1 second to save the setting.
  - MF is displayed in red on the monitor.

**4 Take the picture.**

- The focus is locked at the distance you have set.

**● To cancel manual focus**

**1 Hold down**  **for more than 1 second to display the focus distance selection screen.**

**2 Press**  **to select AF, then press** .

- Manual focus is canceled.



MF &gt; AF



**TIPS** - - - - -

**? How to shoot while keeping the same focus distance at all times**

→ The focus can be fixed at the same distance as when you perform focus lock.

- 1 Position the AF target mark on a subject at the desired distance and press the shutter button halfway.
- 2 Keeping the shutter button half-pressed, press .
  - The distance indicator is displayed.
  - MF is selected and the focus is locked at the same distance as when you performed focus lock.

**Even if you move the cursor to the top of the distance indicator, focusing is not possible at ∞.**

→ Adjust the cursor position by pressing   while watching the monitor.

- !**
- If the zoom lever is pressed after performing manual focus, the saved focus distance may be changed. Perform setting again.

Note



There are three ways of measuring the brightness of a subject.

**Digital ESP metering** Meters the center of the subject and the surrounding area separately.

**Spot metering** Exposure is determined by metering within the AF target area. In this mode, a subject can be shot with optimal exposure regardless of the background light. P.75

**Multi-metering** Meters the brightness of the subject at up to 8 different points to set the optimal exposure based on the average brightness. This method is useful with a high contrast subject. P.76

## Spot metering

Mode dial



1 Select or by repeatedly pressing .

- If no operation is performed for about 3 seconds, the selected mode is set and the mode selector screen is automatically exited.
- is not available in manual focus mode. “Manual focus” (P.73)

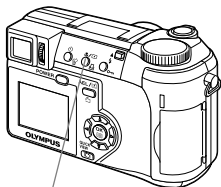

Macro/Spot button

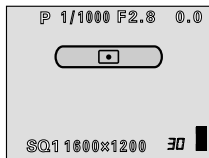

## MULTI METERING

Mode dial



- 1** When using the camera in the **A/S/M** mode, multi-metering is not available in the **M** mode. Set to any mode except **M**.

☞ "A/S/M mode" (P.63)

- If a function other than AE lock is registered on **AEL** / , set AE lock to the button.

☞ "Setting the custom button" (P.131)

- 2** Press  /  repeatedly to set





☞ "Spot metering" (P.75)



- 3** In the top menu, select **MODE MENU** → **CAMERA** → **MULTI METERING** → **ON**, and press .

☞ "How to use the menus" (P.33)

- Press  again to exit the menu.

- 4** Position the **AF** target mark on the area you want to meter and press **AEL** / . The brightness is metered at up to 8 different points.

- Multi-metering bar appears.
- Brightness meter readings are ignored after the 9th reading.
- To perform metering again, press **AEL** /  for more than 1 second to display **MEMO**. Press **AEL** /  again to cancel the metering values.

 /  Macro/Spot button  
**AEL** /   
**AEL**/Custom button

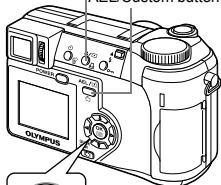

Ex: When metering 2 points (pressing **AEL**/**AE-L** twice)

The aperture and shutter speed as calculated from the average values obtained by metering at 2 points. These values are recalculated every time another metering point is added.

The average for the 2 metering points. The average is always shown at the center of the bar.

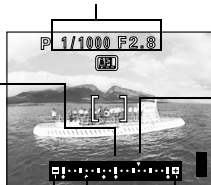

Indicates how much the present exposure you are metering differs from the average exposure value. The present exposure can be fixed by pressing the shutter button halfway. (The present exposure is not added to the average value unless you press **AEL**/**AE-L**.)

The reading with **AEL**/**AE-L** was pressed.  $\diamond$  indicates the number of times you have pressed the button.  $\diamond$  indicates the difference between the metered and average readings.

When  $\diamond$  moves more than  $\pm 3$  from the center of the bar (the average reading), red  $\triangleleft$   $\triangleright$  appear.

**TIPS** - - - - -

**To save the multi-metered exposure after shooting (AE memory)**  
 → After metering in step 4, hold down **AEL**/**AE-L** for more than 1 second. **MEMO** appears. While **MEMO** is displayed, the exposure is saved. Press **AEL**/**AE-L** again to cancel the AE memory.

**The multi-metering exposure is canceled.**

→ If you operate any of the buttons or the mode dial after metering in step 4, the multi-metering exposure is canceled.

# AE LOCK - Locking the exposure **AEL**

This function is suitable for situations when optimal exposure is difficult to achieve, such as when there is excessive contrast between the subject and the surroundings.

For example, if the sun is in the frame and shooting with automatic exposure results in a dark subject, recompose your shot so that the sun is not in the frame. Then press **AEL** /  to lock the metered value (exposure) temporarily. Next, compose your shot again with the sun in the frame and take the picture.



Mode dial





5

Advanced shooting

- 1 When using the camera in the **A/S/M** mode, AE lock is not available in the **M** mode. Set to any mode except **M**.

 "A/S/M mode" (P.63)

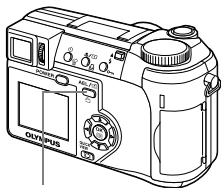

- If a function other than AE lock is registered on **AEL** / , set AE lock to the button.

 "Setting the custom button" (P.131)



**AEL** /  AEL/Custom button

- 2 Compose the picture where you want to lock the metered value (exposure), then press **AEL** / .

- The exposure is memorized.
- If you want to lock a different exposure, press **AEL** /  again to cancel AE lock. Each time you press **AEL** / , AE lock is alternately engaged and canceled.

### 3 Position the AF target mark on the subject you want to focus on and press the shutter button halfway.

- The green lamp lights.
- AE lock cannot be canceled while the shutter button is pressed halfway.



During AE lock, AEL is displayed.



### 4 Press the shutter button fully.

- AE lock is automatically canceled after one shot.



#### TIPS

**To save the locked metered value (exposure) after shooting (AE memory)**



- After step 2 or 3, hold down **AEL**/ for more than 1 second. **MEMO** appears. While **MEMO** is displayed, the exposure is saved. Press **AEL**/ again to cancel the AE memory.

**AE lock was canceled.**

- Do not operate any of the buttons or the mode dial after performing AE lock. Doing so will cancel AE lock.
- The camera had emerged from sleep mode or the power was turned off.



Note

- AE lock is not available when MULTI METERING is enabled. Turn multi-metering off.  "MULTI METERING" (P.76)
- AE lock is not available when a menu is displayed on the screen. Exit the menu.  "How to use the menus" (P.33)



# Macro mode shooting



Focusing is usually slow when you get close to a subject (W: 7 cm/2.8" to 60 cm/2.0 ft., T: 1.2 m/3.9 ft. to 2 m/6.6 ft.). However, in the  mode focusing is performed quickly. When the optical zoom lever is at the maximum wide position and you are as close as 7 cm/2.8" to your subject, you can fill the entire frame with your subject.

If the center of the frame (within the AF target mark) is metered when you are close to the subject and you shoot with the optimal exposure, the picture will turn out well (spot metering+macro mode). (P.75)

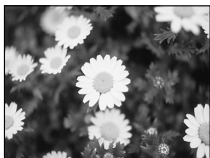

Normal shooting



With the macro mode





## 5

### Advanced shooting

Mode dial



#### 1 Select or / by repeatedly pressing / .

- The selected mode is set.
- If no operation is performed for 3 seconds, the mode selector screen is automatically exited.
- You cannot select  and  /  in manual focus mode. Set to AF.  
 "Manual focus" (P.73)



  
Macro/  
Spot button

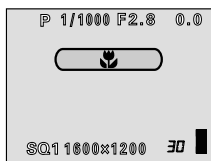

# Super macro mode shooting



This mode lets you shoot from as close as 3 cm/1.2" to your subject. Subjects measuring up to approximately 4 × 3 cm (1.6" × 1.2") can be captured on the monitor.

In the **s** mode, normal shooting is also possible, but the position of the zoom is fixed automatically and cannot be changed.

Mode dial



- 1 In the top menu, select **MODE MENU** → **CAMERA** → **s** → **ON**, and press

"How to use the menus" (P.33)

- Press again to exit the menu.

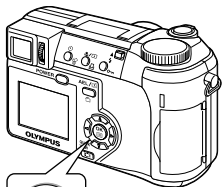

## TIPS

### The subject is in shadow

→ When taking pictures close to the subject, shadows may become conspicuous, and the auto focus may not be able to maintain correct focus. If this happens, use the manual focus. "Manual focus" (P.73)



Note

- During super macro shooting, zoom and flash are not available.

# Self-timer shooting



This function lets you take pictures using the self-timer. Fix the camera securely on a tripod for self-timer shooting. This function is useful for taking pictures where you want to be included in the photograph.

Mode dial



## 1 Select by repeatedly pressing





- If no operation is performed for about 3 seconds, the selected mode is set and the mode selector screen is automatically exited.

 Self-timer button

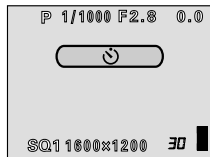
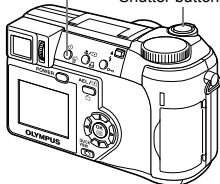
Shutter button



## 2 Press the shutter button fully to take the picture.

- Pressing the shutter button halfway locks the focus and exposure.
- The self-timer lamp lights for approximately 10 seconds, then starts blinking. After blinking for approximately 2 seconds, the picture is taken.
- To stop shooting while in  mode, press the shutter button fully again.
- To cancel the self-timer, press .
- The self-timer mode is automatically canceled after one shot.

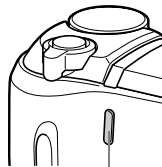

Self-timer lamp

5

Advanced shooting



Note

- If sequential shooting is attempted in self-timer mode, the camera shoots max. 5 frames regardless of the setting.



There are 4 sequential shooting modes: sequential shooting, high speed sequential shooting, AF sequential shooting and auto bracketing. Sequential shooting modes can be selected from the DRIVE mode menu.

Sequential shooting cannot be performed when the record mode is set to TIFF.

### Drive mode

- : Shoots 1 frame at a time when the shutter button is pressed.  
(Normal shooting mode, single-frame shooting)
- : Focus, exposure and white balance are locked at the first frame.  
Approx. 11 frames at 1.4 frames/sec. (in HQ mode)
- HI** : Pictures can be taken at a faster speed than normal sequential shooting. The sequential shooting speed varies depending on the record mode setting.  
Approx. 3 frames at 2 frames/sec.
- AF** : Focus is individually locked for each frame. The AF sequential shooting speed is slower than for normal sequential shooting.
- BKT** : "Auto bracketing" (P.84)

## Sequential shooting, high speed sequential shooting and AF sequential shooting **HI** **AF**

Mode dial



- 1 In the top menu, select **MODE MENU** → **CAMERA** → **DRIVE** → , **HI** or **AF** , and press .
- "How to use the menu" (P.33)

- Press again to exit the menu.

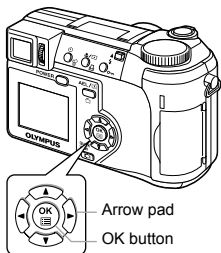

## 2 Take the picture.

- Press the shutter button fully and keep it pressed. The camera will take pictures in sequence until you release the button.
- During sequential shooting, the subject does not appear on the viewfinder and monitor.

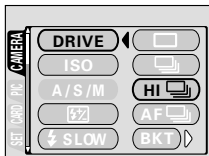

## Auto bracketing BKT

Under some conditions, you may obtain better results shooting with exposure compensation than by using the exposure setting considered optimal by the camera.

When auto bracketing is set, the exposure is changed automatically for each frame when you start shooting. The exposure differential and number of frames can be selected in the menus. The focus and white balance are locked at the first frame.

5

Advanced shooting

Ex: When **BKT** is set to  $\pm 1.0 \times 3$

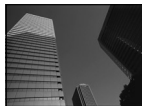

-1.0



0.0



+1.0

Mode dial



- 1 In the top menu, select **MODE MENU** → **CAMERA** → **DRIVE** → **BKT**, and press

"How to use the menus" (P.33)

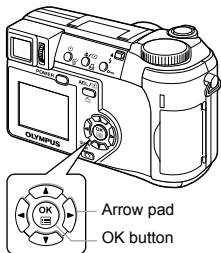

- 2 Select the exposure differential.**  
Press to select  $\pm 0.3$ ,  $\pm 0.7$  or  $\pm 1.0$ , then press .

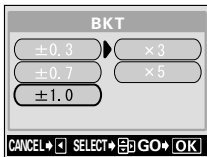

- 3 Select the number of shots.** Press to select  $\times 3$  or  $\times 5$ , then press .
- Press repeatedly until the menu disappears.
- 4 Take the picture.**
- Press the shutter button fully and keep it pressed to shoot the preset number of pictures. You can stop shooting at any time by releasing the shutter button.



- Auto bracketing is not possible in **M** mode.
- Sequential shooting (, **HI** , **AF** , **BKT**) is not possible in the following situations:
  - When the TIFF or SHQ record mode is set to ENLARGE SIZE
  - When NOISE REDUCTION is set to ON.
- The flash does not fire in **BKT** mode.
- If there is not enough space available on the card for the number of frames you have set during auto bracketing, you cannot continue shooting.
- If the battery power is low and the battery check blinks during sequential shooting, shooting stops and the camera starts saving the pictures you have taken. Whether or not all of the shots are saved depends on how much battery power remains.
- Since the shutter speed is set to max. 1/30 sec., exposure is decreased when shooting a dark subject.

# PANORAMA - Panorama shooting

You can take advantage of panorama shooting with Olympus CAMEDIA-brand cards (xD-Picture Card). Panorama shooting lets you connect pictures with overlapping edges into a single panoramic picture, using the CAMEDIA Master software.

Mode dial





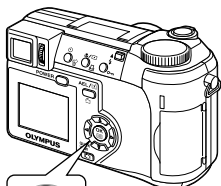

- 1 In the top menu, select **MODE MENU** → **CAMERA** → **PANORAMA**, and press .

 "How to use the menus" (P.33)

- The PANORAMA mode is set.



- 2 Use the arrow pad to choose at which edge you want to connect the pictures.

-  : The next picture is connected at the right edge
-  : The next picture is connected at the left edge
-  : The next picture is connected at the top
-  : The next picture is connected at the bottom

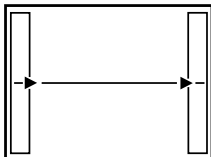

Connects pictures from left to right

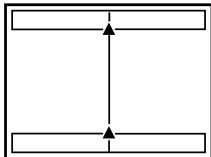

Connects pictures from bottom to top

5

Advanced shooting

### 3 Make sure that the edges of the pictures overlap, then take pictures.

- Focus, exposure and white balance are set by the first picture. Do not select an extremely bright subject (such as the sun) for the first picture.
- You cannot adjust the zoom after the first picture.
- Panorama shooting is possible for up to 10 pictures.

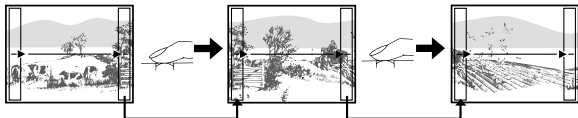

The part of the previous picture where it will be joined to the next picture does not remain in the frame on the edge of the screen. You have to remember what the part in the frame looked like and take the next picture so it overlaps. Compose your shots so that the right edge of the previous picture overlaps with the left edge of the next picture if you are connecting pictures from left to right (or vice versa if you are connecting pictures from right to left).

- When you have taken 10 pictures, a warning mark appears.



### 4 Press to finish panorama shooting.

- The frame on the screen disappears and the camera returns to the normal shooting mode.



Note

- The panorama mode is only available with Olympus CAMEDIA-brand cards.
- Your computer's memory may be insufficient if you take too many panorama pictures in HQ or SHQ mode. You are recommended to use SQ mode for panorama shooting.
- During panorama shooting, the flash and sequential shooting are not available.
- Images are saved in JPEG format when panorama shooting is done in the TIFF mode. The size of the image does not change.
- If the mode dial is operated during panorama shooting, the camera cancels the panorama mode and returns to normal shooting.
- The camera itself cannot connect panorama pictures. The CAMEDIA Master software is necessary to connect the pictures.



# 2 IN 1 - Taking two-in-one pictures

This function allows you to combine two pictures taken in succession and store them as a single picture. You can combine two different subjects in one picture.



Picture when played back

Mode dial



- 1 In the top menu, select **MODE MENU** → **CAMERA** → **2 IN 1**, and press

"How to use the menus" (P.33)

- The 2 IN 1 picture mode is set.

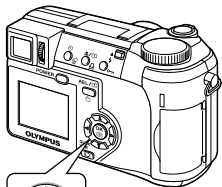

- 2 Take the first shot.

- The subject will be positioned on the left in the combined picture.



- 3 Take the second shot.

- The subject will be positioned on the right in the combined picture.
- The **BUSY** bar is displayed during processing. After the image is saved, the camera returns to the mode menu.

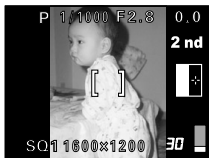



Image when shot

5

Advanced shooting



Note

- During 2 IN 1 picture shooting, the panorama and sequential shooting modes are not available.
- To cancel 2 IN 1 picture mode after the first shot has been taken, press . The first shot will not be saved.
- Operating the mode dial will exit 2 IN 1 picture mode.
- If the camera enters sleep mode after the first shot, 2 IN 1 picture mode will be canceled.

# FUNCTION - Adding special effects to pictures

This feature lets you add special effects to your pictures during shooting. 4 effects are available.

**BLACK & WHITE** Takes pictures in black and white.

**SEPIA** Gives pictures a sepia tone.

**WHITE BOARD** Pictures are in black and white, with black letters on a white background emphasized to make them easier to read.

**BLACK BOARD** Pictures are in black and white, with white letters on a black background emphasized to make them easier to read.

Mode dial



- 1 In the top menu, select **MODE MENU** → **CAMERA** → **FUNCTION**, then select a mode and press

“How to use the menu” (P.33)

- **WHITE BOARD** and **BLACK BOARD** are not available in mode.
- Press again to exit the menu.

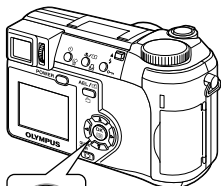

Arrow pad

OK button

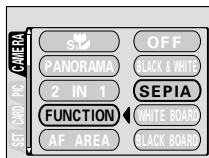

## TIPS

Letters do not show clearly with **WHITE BOARD** or **BLACK BOARD**.

→ Use exposure compensation. “Exposure compensation” (P.97)



Note



- When **WHITE/BLACK BOARD** is selected, the flash is automatically set to off.
- **WB**, and **SATURATION** cannot be used in Function shooting.

## 6 Adjusting the image quality and exposure

### Record mode



You can select a record mode in which to take pictures or shoot movies. Choose the best record mode for your purpose (printing, editing on a PC, website editing, etc.). For details of the different record modes, resolutions and number of pictures storable on the card, refer to the table on the next page. The numbers in the table are approximate.

Record mode	Description	Quality	File size
TIFF	The highest quality mode. As the images are saved as uncompressed data, this is the best mode for printing or image-processing on a PC. This mode has different resolutions to choose from, depending on your purpose. Selecting <b>3:2</b> lets you print the entire image without losing its borders - almost the same image size as that used by photo labs.	 Clearer	 Larger
SHQ	A high quality mode using the JPEG format. Because the compression rate is very low, high quality can be maintained. Selecting <b>3:2</b> lets you print the entire image without losing its borders - almost the same image size as that used by photo labs. The ENLARGE SIZE function is useful when printing on large-format paper.		
HQ	A high quality mode with medium compression. Because the compression rate is higher than SHQ, file sizes are smaller, so more images can be saved to a card. Like SHQ, resolution can be changed by using <b>3:2</b> or the ENLARGE SIZE function.		
SQ1 SQ2	The most compressed modes. For each resolution, you can choose HIGH (to reduce noise) or NORMAL (to save more images). Select the best setting for your purpose (printing, Internet pages, etc.).		
		Normal	Smaller

## Still Picture Record Modes

Record mode	Resolution		Compression	File format	Memory capacity in no. of shots	
					16MB	32MB
TIFF	2048 × 1536		Uncompressed	TIFF	1	3
	<b>3:2</b>	2048 × 1360			1	3
	1600 × 1200				2	5
	1280 × 960				4	8
	1024 × 768				6	13
	640 × 480				16	33
SHQ	2048 × 1536		Low compression	JPEG	8	16
	<b>3:2</b>	2048 × 1360			8	17
	<b>ENLARGE SIZE</b> 3200 × 2400				2	5
HQ	2048 × 1536		NORMAL		20	40
	<b>3:2</b>	2048 × 1360			22	45
	<b>ENLARGE SIZE</b> 3200 × 2400				8	17
SQ1	1600 × 1200	HIGH	*		11	22
		NORMAL			32	64
	1280 × 960	HIGH			17	34
		NORMAL			49	99
SQ2	1024 × 768	HIGH		26	53	
		NORMAL		76	153	
	640 × 480	HIGH		66	132	
		NORMAL		165	331	

\* HIGH uses low compression/NORMAL uses normal compression

## Movie Record Modes

Record mode	Resolution	16MB	32MB
HQ	320 × 240 (15 frames/sec.)	48 sec.	96 sec.
SQ	160 × 120 (15 frames/sec.)	211 sec.	424 sec.



Note

- The card memory capacity listed in the table is approximate.
- The number of remaining pictures may change according to the subject or factors like whether print reservations have been made or not. In certain instances, the number of remaining pictures does not change even when you take pictures or stored images are erased.
- If movies are shot with VIDEO OUT set to PAL and the video cable connected, the movie recording time will differ from the time listed in the Movie Record Modes table.

## Selecting a record mode

Mode dial



- In the top menu, select **MODE MENU** → **PICTURE** → and press .

"How to use the menus" (P.33)

- If is displayed on the top menu as a shortcut menu, press the arrow pad in the same direction as the arrow shown next to .

"SHORT CUT" (P.133)

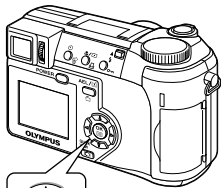

Arrow pad

OK button

Mode dial

**AUTO**

In the top menu, press to select , and choose **SHQ 2048 × 1536**, **HQ 2048 × 1536**, **SQ1 1280 × 960** or **SQ2 640 × 480**. Go to Step 4.

Mode dial



In the top menu, press to select , then press to select **HQ** or **SQ**. Go to Step 4.

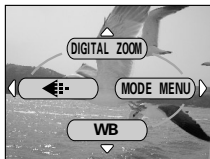

6

Adjusting the image quality and exposure

- 2 Press to select the desired record mode from TIFF, SHQ, HQ, SQ1 and SQ2, then press .
- 3 Press to select the resolution. If you have selected SQ1 or SQ2, press after choosing the resolution, then choose HIGH or NORMAL by pressing .
- 4 Press .
  - Press again to exit the menu.

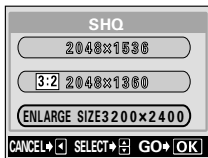

## TIPS

- **Resolution**

The number of pixels (horizontal × vertical) used when saving an image. If the image will be printed, higher resolutions (larger numbers) are recommended so that the image will be clearer. However, higher resolutions make the file size (amount of data) larger, so the number of pictures that can be saved will be fewer.

- **Resolution and picture size on a computer screen**

When a picture is transferred to a computer, the size of the picture on the computer screen varies depending on the computer's monitor setting. For instance, a picture taken in 1024 × 768 resolution is the same size as the screen if you set the picture to 1x when the monitor setting is 1024 × 768. However, if the monitor setting is over 1024 × 768 (such as 1280 × 1024), the picture only takes up part of the screen.

- **Compression rate**

In record modes other than TIFF, image data are compressed. The higher the compression rate, the less clear the image will be.

- **File format**

This camera saves images in either TIFF or JPEG format. In record modes other than TIFF, images are compressed in the JPEG format. The compression rate also varies in each mode. (Movies are in Motion JPEG format (.mov).)

## 3:2 Resolution

The image aspect ratio is normally 4:3. If the aspect ratio is changed to 3:2, the image can be printed at a photo lab without losing the image borders. When **3:2** is activated, the resolution is 2048 × 1360 pixels. **3:2** resolution can be selected in the TIFF, SHQ or HQ mode. **3:2** resolution is not available in **AUTO** or  mode.





Monitor display  
when **3:2** is set

## ENLARGE SIZE

When ENLARGE SIZE is selected, the actual 3.2 million pixels used by this camera can be increased to the equivalent of approx. 8 million pixels (3200 × 2400). This allows you to make quality prints in larger sizes, such as A3 (297 mm × 420 mm/11.7" × 16.5"). However, file sizes also become larger. ENLARGE SIZE can be selected in the SHQ or HQ mode. ENLARGE SIZE is not available in the **AUTO** or  mode.



Note

- If the SHQ record mode is set to ENLARGE SIZE, sequential shooting modes (, **HI** , **AF** , **BKT**) are not available.



# ISO sensitivity

The higher the ISO value, the greater the camera's light sensitivity and the better its ability to shoot in low light conditions. However, higher values also introduce electrical noise into the resulting image, which may give them a grainy appearance.

- AUTO** Sensitivity is automatically adjusted according to the light conditions and the subject brightness.
- 100/200/400** With a lower ISO setting, you can shoot clear, sharp images in daylight. With a higher ISO setting, you can use faster shutter speeds with the same amount of light.

## Mode dial



- 1 In the top menu, select **MODE MENU** → **CAMERA** → **ISO**, then choose the most suitable **ISO sensitivity** and press **OK**.

☞ "How to use the menu" (P.33)

- **AUTO** is not available in **A/S/M** mode.
- Press **OK** again to exit the menu.

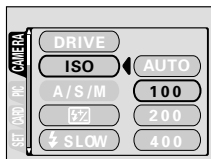
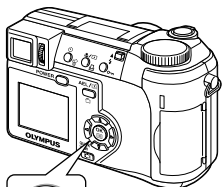

Note

- Higher ISO settings produce more electrical noise.
- ISO is standardized based on the sensitivity of normal camera film. The scale is approximate.
- When ISO is set to **AUTO** and you are shooting in dark conditions without a flash, the sensitivity automatically increases, otherwise the shutter speed will be reduced, possibly resulting in camera movement and blurred images.
- If the subject is too far away for the flash illumination to reach when ISO is set to **AUTO**, the sensitivity is automatically increased.

# Exposure compensation



This function allows you to make fine changes to the present exposure setting using the arrow pad. In some situations, you may get better results when the exposure that the camera sets is compensated (adjusted) manually. You can adjust the exposure in the range of  $\pm 2.0$  in  $1/3$  steps. When the setting is changed, you can check the result on the monitor or viewfinder.

Mode dial



## 1 Press to select a setting.

- Adjust toward + : Press to adjust up to +2.0 in  $1/3$  steps.
- Adjust toward - : Press to adjust up to -2.0 in  $1/3$  steps.

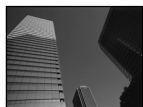
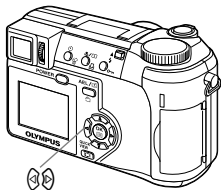

-2.0



0.0



+2.0



### TIPS

- Often bright subjects (such as snow) will turn out darker than their natural colors. Adjusting toward + makes these subjects closer to their real shades. For the same reason, adjust toward - when shooting dark subjects.



Note

- You can set the aperture by pressing in **M** mode. “Manual shooting” (P.66)
- If the flash is used, the image brightness (exposure) may differ from the intended brightness.
- Exposure compensation cannot correct the image if the surroundings of the subject are extremely bright or dark.

6

Adjusting the image quality and exposure

Color reproduction differs depending on the light conditions. For instance, when daylight, the setting sun or tungsten lighting are reflected on white paper, the shade of white produced will be slightly different for each. By setting the WB (white balance), you can achieve more natural-looking colors.

Mode dial





- 1** In the top menu, select **MODE MENU** → **PICTURE** → **WB**, and press .





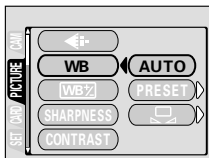
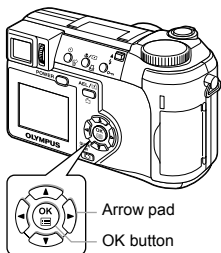

 “How to use the menus” (P.33)

- If WB is displayed on the top menu as a shortcut menu, press the arrow pad in the same direction as the arrow shown next to WB.

 “SHORT CUT” (P.133)

- 2** Press   to select **AUTO**, **PRESET** or  according to the shooting conditions.



- AUTO** Press . Press  again to exit the menu.
- PRESET** Press  to display the next selection screen.  
 “Preset white balance” (P.99)
-  Press  to display the next selection screen.  
 “One-touch white balance” (P.99)

## Auto white balance

Automatically adjusts the white balance for any light source.

## Preset white balance

Select a preset white balance setting according to the type of light. Press to select one of the following settings, then press .

Press again to exit the menu.

: For shooting on a sunny day.

: For shooting on a cloudy day.

: For shooting under a tungsten light (3000K)\*.

: For shooting under a daylight fluorescent lamp (6700K)\*. This type of lamp is used mainly in homes.

: For shooting under a neutral white fluorescent lamp (5,000K)\*. This type of lamp is generally used in desk lamps, etc.

: For shooting under a cool white fluorescent lamp (4,200K)\*. This type of lamp is generally used in offices, etc.

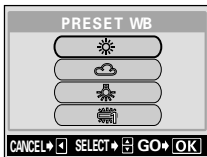

\* The color temperature values (K) are approximate. They are not an accurate indication of color.



### TIPS

- You can also preview different color tones by trying the different PRESET WB settings under the actual light source and checking the result on the monitor.

## One-touch white balance

This function is useful when you need a more precise white balance than PRESET WB can provide. To set the optimum white balance for the shooting conditions, point the camera at a white object under the light source you want to use and adjust the white balance.

### 1 Display screen and point the camera at a sheet of white paper.

- Position the paper so that it fills the screen, making sure there are no shadows.



**2 Press .**

- The white balance is set and the screen returns to the mode menu.
- To cancel one-touch white balance, press .

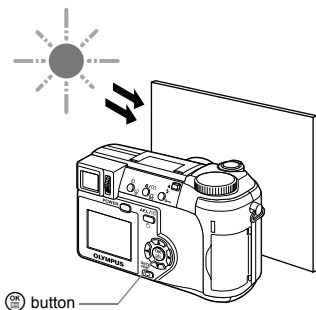

One-touch white balance

**3 Press  repeatedly to exit the menu.**

Note

- When setting the white balance by pointing the camera at a sheet of white paper, the correct setting may not be obtained if the light reflected by the paper is too bright or too dark.
- White balance may not be effective under some special light sources.
- After setting a white balance other than AUTO, play back the picture and check the colors on the monitor.
- When the flash is fired with a white balance setting other than AUTO, colors may appear different in the resulting picture from the colors you see on the monitor.

## White balance adjustment

This function lets you make fine changes to the current white balance setting.

Mode dial





- In the top menu, select **MODE MENU** → **PICTURE** → , and press .

 “How to use the menus” (P.33)

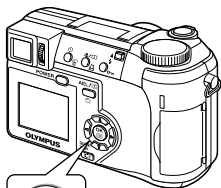
- The white balance adjustment indicator appears on the screen.



- The color becomes bluer each time you press , and redder each time you press , depending on the original white balance conditions. Press  to save your adjustment.

- The white balance can be adjusted in 7 increments in both red and blue directions.
- After saving the adjustment, press  again to exit the menu.



6

Adjusting the image quality and exposure

This function adjusts the sharpness of the image.



Mode dial



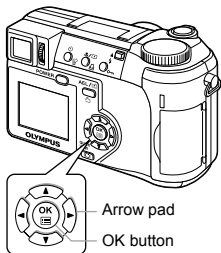

- In the top menu, select **MODE MENU** → **PICTURE** → **SHARPNESS**, and press .



 "How to use the menus" (P.33)

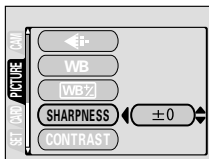

- Press   to adjust the sharpness between **+5** and **-5**.

- To increase the sharpness (+) :  
Press . The image contours are emphasized, making the image appear sharper and more vivid. Use this setting when you want to print pictures.
- To reduce the sharpness (-) :  
Press . The image contours are softened. Use this setting when you want to edit images on a PC.



- When you have finished setting the sharpness, press . Press  again to exit the menu.



- If you adjust the sharpness too far toward +, noise may become conspicuous in the picture.

This function adjusts the contrast of images. For example, you can make images with marked differences in light and shadow softer, and those with less differences more vivid.

## Mode dial



- 1 In the top menu, select **MODE MENU** → **PICTURE** → **CONTRAST**, and press

“How to use the menus” (P.33)

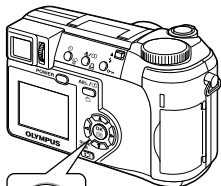

- 2 Press to adjust the contrast between **+5** and **-5**.

- To increase the contrast (+) :  
Press . The light and dark areas are defined more clearly, making the image look crisper.
- To reduce the contrast (-) :  
Press . The light and dark areas become less defined, giving the image a softer impression. Use this setting when you want to edit images on a PC.
- When you have finished setting the contrast, press . Press again to exit the menu.

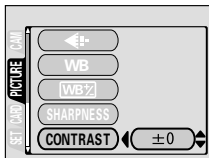



This function adjusts the color depth.

Mode dial



- 1 In the top menu, select **MODE MENU** → **PICTURE** → **SATURATION**, and press

"How to use the menus" (P.33)

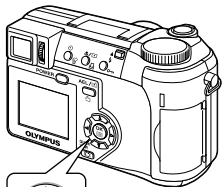

Arrow pad

OK button

- 2 Press to adjust the saturation between **+5** and **-5**.

- To increase the saturation (+):  
Press . Colors become darker and more intense.
- To reduce the saturation (-):  
Press . Colors become lighter.

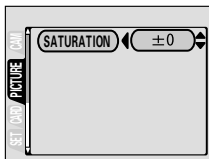

- When you have finished setting the saturation, press . Press again to exit the menu.

# NOISE REDUCTION

This function reduces the noise that is generated during long exposures. When shooting night scenes, shutter speeds become slower and noise tends to appear on images. When noise reduction is set to ON, the camera automatically reduces noise to produce clearer images. However, shooting time is approximately twice as long as usual.

Noise reduction can only be used when the shutter speed is set slower than 1 sec.



Noise Reduction: OFF



Noise Reduction: ON

The purpose of these pictures is to illustrate the effects of noise reduction. They are not actual pictures.

Mode dial

A/S/M P

- 1 In the top menu, select **MODE MENU** → **CAMERA** → **NOISE REDUCTION** → **ON** or **OFF**, and press .

"How to use the menus" (P.33)

- Press again to exit the menu.

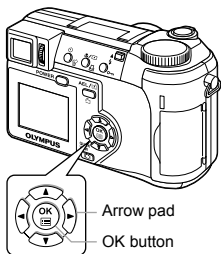

6

Adjusting the image quality and exposure



Note

- Noise reduction is always enabled in the mode.
- When noise reduction is set to ON, the camera implements noise-reducing processes after each shot to produce clearer images. However, shooting time is approximately twice as long as usual. During this time, the next shot cannot be taken.
- When noise reduction is set to ON, sequential shooting (, **HI** , **AF** , **BKT**) is not possible.
- This function may not work effectively with some shooting conditions or subjects.
- As the shutter speed is relatively slow, the use of a tripod is recommended.

# Histogram display



During shooting and playback, you can display a histogram showing the brightness and contrast of your subject in the monitor or viewfinder. Checking the histogram enables precise exposure control when taking pictures.

During playback, you can display a histogram showing the brightness and contrast of recorded pictures.

The histogram display can be set separately for shooting mode and playback mode.

Ex: When a histogram is displayed in **P** mode

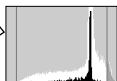

The part indicated in green in the histogram shows the luminance distribution within the AF target mark.

When the image is bright

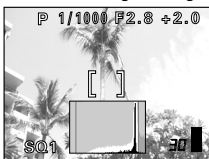

If the peak fills too much of the right frame, the image will appear mostly white.

When the image is dark

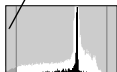
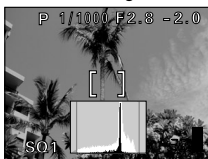

If the peak fills too much of the left frame, the image will appear mostly black.

## Mode dial



- 1 In the top menu, select **MODE MENU** → **CAMERA** → → **ON** or **OFF**, and press .

"How to use the menus" (P.33)

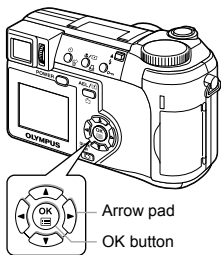

- When ON is selected, the histogram is displayed.
- Press again to exit the menu.

## Mode dial



Press in the top menu.

"How to use the menus" (P.33)

- The histogram is displayed.
- To return to the normal playback screen, press again to display the top menu and press .

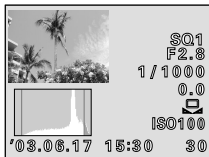

Playback mode



Note

- The histogram is not displayed in the following situations even if histogram display is set to ON.  
During **M** mode, panorama shooting, 2 IN 1 shooting and multi-metering
- The histogram displayed during shooting may differ from the histogram displayed during playback.
- A histogram may not appear when you play back pictures shot on another camera.

# 7 Playback

## Viewing still pictures



### Mode dial



- 1 Set the mode dial to and press the power switch.

"Power on/off" (P.24)

- The monitor turns on and displays the last picture taken. (Single-frame playback)

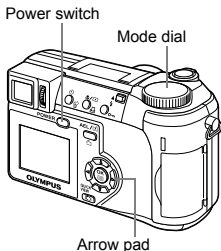

- 2 Use the arrow pad to play back other pictures.

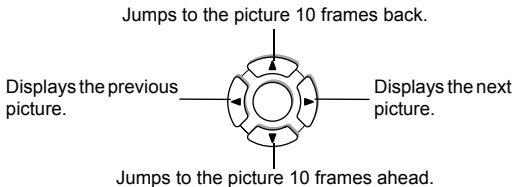

Note

- If the camera is not used for over 3 minutes, the camera enters the sleep mode and the monitor turns off.

## QUICK VIEW

This function lets you play back pictures while the camera is in the shooting mode. This is useful when you want to check shooting results and resume shooting quickly.

Functions available in normal playback mode are also available in QUICK VIEW.



**1** Press  twice quickly (double-click) while in the shooting mode.

- The camera immediately enters the playback mode and displays the last picture taken. (Single-frame playback)

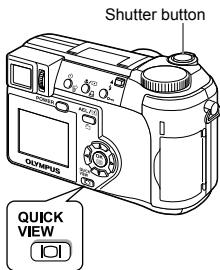

**2** Press the shutter button halfway to return to the shooting mode.



Pictures displayed on the monitor can be enlarged 1.5, 2, 2.5, 3, 3.5 or 4 times.

## Mode dial



### 1 Select the still picture you want to enlarge.

- You cannot enlarge pictures with .

### 2 Pull the zoom lever toward T (Q).

- Each time you pull the zoom lever, the picture is enlarged gradually.
- By using the arrow pad while the enlarged picture is displayed, you can shift the picture in the desired direction, enabling you to view a different portion.
- To return the picture to the original size (1x), push the zoom lever toward W.

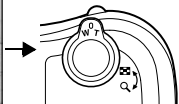

7

Playback



Note

- Pictures cannot be stored in an enlarged state.



This function lets you show several pictures at the same time on the monitor. The number of pictures shown can be 4, 9 or 16. “Selecting the number of pictures” (P.112)

**Mode dial**



## 1 In the single-frame playback mode, push the zoom lever toward W

- Use the arrow pad to select the picture.
  - : Moves to the previous frame.
  - : Moves to the next frame.
  - : Jumps to the previous index display (the frames before the top left frame).
  - : Jumps to the next index display (the frames following the bottom right frame).
- To return to the single-frame playback, pull the zoom lever toward T.

Zoom lever

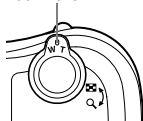



## Selecting the number of pictures

This function lets you select the number of pictures in an index display from 4, 9 and 16.

### Mode dial



- In the top menu, select **MODE MENU** → **SETUP** → → **4, 9 or 16**, and press .

- Press again to exit the menu.

"How to use the menus" (P.33)

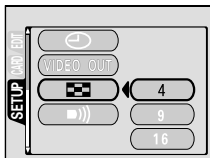
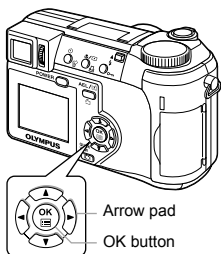



This function displays still pictures stored in the card one after another. Only the first frame of movies is played back.

## Mode dial



- 1 Select a still picture, then press to display the top menu.

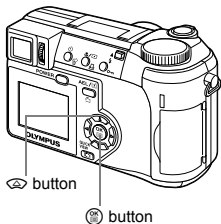

- 2 Press to start the slideshow.

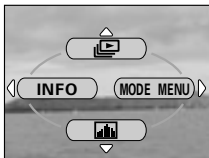

- 3 Press to stop the slideshow.
  - The slideshow will not stop until you cancel it by pressing .



Note

- You are recommended to use the optional AC adapter when running a slideshow for a long period of time. If batteries are used, the camera will enter the sleep mode after about 30 minutes and stop the slideshow automatically.



## Mode dial



- 1 Use the arrow pad to display the picture with you want to play back.

"Viewing still pictures" (P.108)

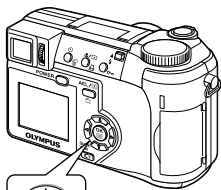

## 7

## Playback

- 2 Press .
  - The top menu is displayed.
- 3 Press to select **MOVIE PLAY**.

- 4 Press to select **MOVIE PLAYBACK**, then press .

- The movie is played back. When playback ends, the display automatically returns to the beginning of the movie.
- Fast forward/fast rewind functions are available during playback.

: Fast forward. Each press switches the speed between  $\times 1$ ,  $\times 2$  and  $\times 20$ .

: Fast rewind. Each press switches the speed between  $\times 1$ ,  $\times 2$  and  $\times 20$ .

- Press  again after playback ends to display the menu.

**PLAYBACK** Plays back the entire movie again.

**FRAME BY FRAME**

Plays back the movie manually one frame at a time.

**EXIT** Leaves the movie playback mode.





Press   to select PLAYBACK, FRAME BY FRAME or EXIT, then press .

### ● When FRAME BY FRAME is selected

 : Displays the first frame of the movie.

 : Displays the last frame of the movie.

 : Displays the next frame. The movie can be played continuously by holding the button down.

 : Displays the previous frame. The movie can be played continuously in reverse by holding the button down.

 : Displays the MOVIE PLAYBACK menu.



#### TIPS - - - - -

- Movies can also be played back in the shooting mode using QUICK VIEW.  "QUICK VIEW" (P.109)



Note

- The card access lamp blinks while the camera is reading the movie from the card. Reading of movies may take considerable time. Do not open the card cover while the card access lamp is blinking, as this may cause not only the data on the card to be damaged, but may also render the card unusable.

# Editing movies

This function lets you create indexes as well as edit movies. You cannot edit movies longer than approximately 35 seconds in HQ mode and 150 seconds in SQ mode.

**INDEX** 9 frames extracted from a movie are displayed as an index to show the movie at a glance. Indexes can be stored on the card as a still picture.

**EDIT** This function lets you erase parts of the movie that you do not want.

## Mode dial



**1** Use the arrow pad to select a picture with

**2** In the top menu, select **MOVIE PLAY**, then choose each item.

"How to use the menus" (P.33)

- Select INDEX P.116
- Select EDIT P.118

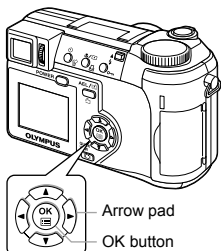

## INDEX - Creating an index

**3** Press to select **INDEX**, then press .

- When there is insufficient card memory, a warning screen appears and the display returns to the setting screen.



#### 4 Use the arrow pad to select the first frame of the index and press .

 : Jumps to the first frame of the movie.

 : Jumps to the last frame of the movie.

 : Displays the next frame. The movie can be played continuously by holding the button down.

 : Displays the previous frame.

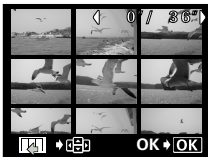

The movie can be played continuously in reverse by holding the button down.

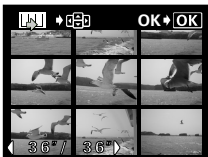

#### 5 As in Step 4, use the arrow pad to select the last frame of the index and press .



#### 6 Press to select OK, then press .

- The 9 frames extracted from the movie appear as an index display, then the camera returns to the playback mode. The index is stored as a new picture.
- If you want to select different frames, select RESET and press  and repeat the procedure from Step 4.
- To quit the editing function, select CANCEL and press .

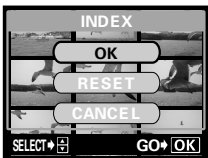

- TIPS** - - - - -
- The index is stored as a still picture in a different record mode from the original movie.

Record mode when the movie was shot	Record mode when stored as an index
HQ	SQ2 (1024 × 768 pixels: HIGH)
SQ	SQ2 (640 × 480 pixels: HIGH)



Note

- The interval between the frames that are automatically picked out varies depending on the length of the movie.
- An index consists of 9 frames.
- You cannot create an index if there is insufficient memory space on the card.

## EDIT - Editing a movie

- 3** Press to select EDIT, then press .



- 4** Use the arrow pad to select the first frame of the part you want to keep and press .

: Jumps to the first frame of the movie.

: Jumps to the last frame of the movie.

: Displays the next frame. The movie can be played continuously by holding the button down.



: Displays the previous frame. The movie can be played continuously in reverse by holding the button down.



- 5** As in Step 4, use the arrow pad to select the last frame of the part you want to keep and press .



## 6 Press to select OK, then press .

- If you want to select different frames, select RESET and press  and repeat the procedure from Step 4.
- To quit the editing function, select CANCEL and press .



## 7 Press to select NEW FILE or OVERWRITE, then press .

**NEW FILE** Stores the edited movie as a new movie.

**OVERWRITE** Stores the edited movie with the same name as the original. The original movie is not stored.



- The edited movie is stored and the screen returns to the playback mode.



Note

- You cannot edit movies with sound which were taken with another digital camera.
- You cannot select NEW FILE if there is insufficient memory space on the card.



# Playback on a TV

Use the video cable provided with the camera to play back recorded images on your TV. You can play back both still pictures and movies on your TV.

**Mode dial**



- 1 Make sure that the TV and camera are turned off. Connect the Video OUT jack on the camera to the Video input terminal on the TV using the video cable.**

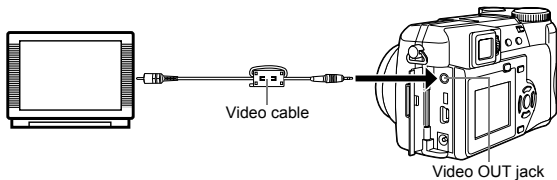

- 2 Turn the TV on and set it to the video input mode.**
  - For details of switching to video input, refer to your TV's instruction manual.
- 3 Set the mode dial to  and turn the camera on.**
  - The last picture taken is displayed on the TV. Use the arrow pad to select the picture you want to display.
  - The close-up playback, index display and slideshow functions can also be used on a TV screen.



## TIPS

- You are recommended to use the optional AC adapter when using the camera with a TV.



Note

- Make sure that the camera's video output signal type is the same as the TV's video signal type.  "VIDEO OUT - Video output selection" (P.151)
- The camera's monitor or viewfinder turns off automatically when the video cable is connected to the camera.
- Be sure to use the video cable provided to connect the camera to the TV.
- The picture may appear off-center on the TV screen.

- When pictures are compressed in order to fit the entire picture on the TV screen, a black frame appears around the picture. If the picture is output to a video printer via the TV, the black frame may be printed.

## Picture rotation

Pictures taken with the camera held vertically are displayed horizontally. This function lets you turn such pictures 90 degrees counterclockwise or clockwise so that they are displayed vertically.

**Mode dial**



### 1 In the single-frame playback mode, press .

- Each pressing rotates the image in the following sequence: 90 degrees counterclockwise, 90 degrees clockwise, and back to the original.

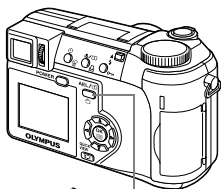

 Rotation button

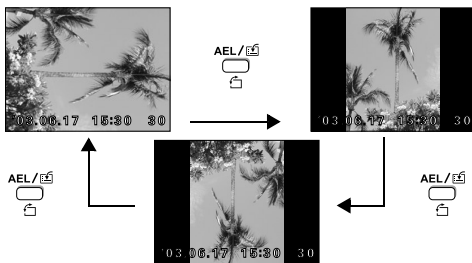

- The following pictures cannot be rotated.  
Movies, protected pictures, pictures that have been edited on a PC, and pictures taken with another camera.
- New picture orientations are saved even when the power is turned off.

# Editing still pictures

This function lets you edit still pictures and store them as new pictures. The following editing operations are possible.

**Resizing**  Changes the picture size to 640 × 480 or 320 × 240 and stores the picture as a new file.

**Trimming**  Crops part of a picture and saves it as a new file.

## Mode dial

- 1 Use the arrow pad to select the still picture you want to edit.
- 2 In the top menu, select **MODE MENU** → **EDIT**, then choose each item.

 "How to use the menus" (P.33)



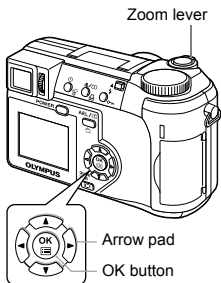

- Select   P.122
- Select   P.123



## Resizing

7

Playback

- 3 Select , then press .
- 4 Press   to select the picture size, then press .



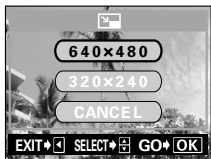













- The **BUSY** bar is displayed during resizing. After the image is saved, the camera returns to the playback mode.
- To quit the resizing function, select **CANCEL**, then press .



Note

- Resizing is not possible in the following cases.
  - Movies, pictures that have been edited on a PC, or when there is insufficient memory space on the card.
- If the size of the selected picture is 640 × 480, you cannot select 640 × 480.

## Trimming

- 3 Select , then press .
- 4 Press   to select , then press .
- 5 Use the arrow pad and zoom lever to decide the trimming position and size.
  - Press     to move the trimming frame.
  - Use the zoom lever to decide the trimming size. The trimming frame changes from horizontal to vertical and vice versa when the maximum or minimum size is reached.
- 6 Press .
- 7 Press   to select OK, then press .
  - The **BUSY** bar is displayed during trimming. After the image is saved, the camera returns to the playback mode.
  - The trimmed picture is stored as a separate picture from the original.
  - If you want to trim the picture again, select RESET and press  and repeat the procedure from Step 5.
  - To quit the trimming function, select CANCEL and press .

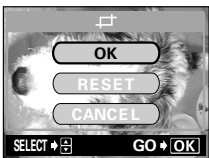

7

Playback



Note

- Trimming is not possible in the following cases.  
Movies, when there is insufficient memory space on the card, or when the picture was taken with the record mode set to ENLARGE SIZE
- It may not be possible to trim pictures taken with another camera.
- If pictures recorded in 3:2 are trimmed, the image proportions are changed to the standard 4:3 aspect ratio.
- If a trimmed picture is printed out, it may appear grainy.

You are recommended to protect important pictures to avoid accidentally erasing them. Protected pictures cannot be erased by the single-frame/all-frame erase function.

## Mode dial

### 1 Use the arrow pad to display the picture you want to protect.

 "Viewing still pictures" (P.108)

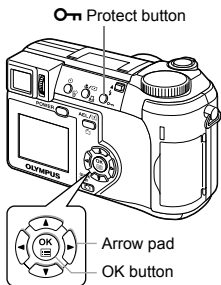

### 2 Press .

- To cancel protection, press  again.



Displayed when a picture is protected.



- Protected pictures cannot be erased by the single-frame/all-frame erase function, but they are all erased by formatting.



This function erases recorded pictures. Pictures can be erased either one frame at a time or all the pictures in the card.



Note

- You cannot erase protected pictures. Cancel protection before erasing such pictures.
- Once erased, pictures cannot be restored. Check each picture before erasing to avoid accidentally erasing pictures you want to keep. “Protecting pictures” (P.125)

## Single-frame erase

Mode dial



- 1 Use the arrow pad to display the picture you want to erase.

“Viewing still pictures” (P.108)

Erase button

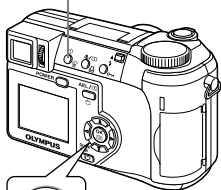

- 2 Press .
    - The ERASE screen is displayed.
  - 3 Press to select YES, then press .
- The picture is erased and the menu is closed.



## All-frame erase

This function erases all the pictures on the card.

Mode dial 

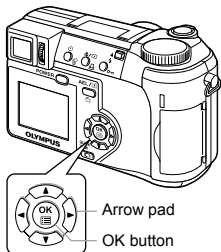

- 1 In the top menu, select **MODE MENU → CARD → CARD SETUP** and press .

 "How to use the menu" (P.33)

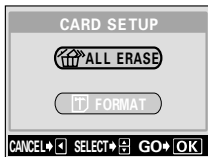

- 2 Press   to select  **ALL ERASE**, then press .



- 3 Press   to select **YES**, then press .

• All the pictures are erased.





## 8 Useful functions

### ALL RESET – Saving the camera's

This function lets you choose whether or not to save the current camera settings after the power is turned off. The settings affected by ALL RESET are listed on the next page.

The All Reset setting (ON/OFF) applies to all the modes. If ALL RESET is set to OFF in one shooting mode, this setting applies to all the other modes, both shooting and playback.

**ON** All settings are returned to the factory default settings after the power is turned off.

**OFF** The settings made before the power is turned off are saved.

Mode dial





- 1 In the top menu, select **MODE MENU** → **SETUP** → **ALL RESET** → **OFF** or **ON**, and press .



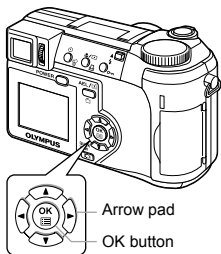







 "How to use the menus" (P.33)

- Press  again to exit the menu.



- My Mode settings and the settings in the **SETUP** tab in the **MODE MENU** (**ALL RESET**, , , , etc.) are saved even when **ALL RESET** is set to **ON**.

## ● Functions that All Reset affects

Function	Factory default setting	Ref. Page	Function	Factory default setting	Ref. Page
F No	F2.8	P.64	DIGITAL ZOOM	OFF	P.54
SHUTTER	1/1000	P.65	FULLTIME AF	OFF	P.69
	±0	P.97	AF MODE	iESP	P.68
FLASH MODE	AUTO	P.55	 S	OFF	P.81
	±0	P.62	FUNCTION	OFF	P.90
AF/MF	AF	P.73	INFO	OFF	P.141
	OFF	P.75, 80		OFF	P.106
	OFF	P.82		HQ	P.91
LCD*	OFF	–	WB	AUTO	P.98
OPTICAL ZOOM	WIDE	P.53		±0	P.101
DRIVE		P.83	SHARPNESS	±0	P.102
BKT	±1, 3 pictures	P.84	CONTRAST	±0	P.103
ISO	AUTO/100	P.96	SATURATION	±0	P.104
A/S/M	A	P.63	TIFF, SHQ, HQ	2048 × 1536	P.93
 SLOW	 SLOW1	P.61	SQ1	1280 × 960 NORMAL	P.93
NOISE REDUCTION	OFF	P.105	SQ2	640 × 480 NORMAL	P.93
MULTI METERING	OFF	P.76	INFO	OFF	P.141

\* This sets whether the monitor turns on or not when the camera is turned on.

# CUSTOM BUTTON



Functions listed in the table below can be assigned to the custom button on the camera. This makes it easy to jump to frequently used functions simply by pressing the custom button without having to select a shortcut menu or MODE MENU from the top menu.



AEL/AF-ON button

Available functions	Settings	Ref. Page
AE LOCK (factory default setting)	–	P.78
AF LOCK	–	P.71
DRIVE	<b>HI</b> <b>AF</b> BKT	P.83
ISO	AUTO, 100, 200, 400	P.96
A/S/M	A, S, M	P.63
SLOW	SLOW1,   SLOW1,  SLOW2	P.61
NOISE REDUCTION	OFF, ON	P.105
DIGITAL ZOOM	OFF, ON	P.54
FULLTIME AF	OFF, ON	P.69
AF MODE	iESP, SPOT	P.68
s	OFF, ON	P.81
FUNCTION	OFF, BLACK & WHITE, SEPIA, WHITE BOARD, BLACK BOARD	P.90
INFO	OFF, ON	P.141
	OFF, ON	P.106
	TIFF, SHQ, HQ, SQ1, SQ2	P.91
WB	AUTO,	P.98

## Setting the custom button

Mode dial



- 1 In the top menu, select **MODE MENU** → **SETUP** → **CUSTOM BUTTON**, and press

☞ “How to use the menu” (P.33)

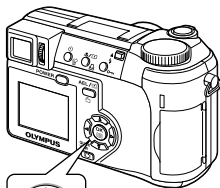

- 2 Press to select a function, then press .

• Press again to exit the menu.

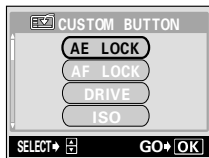

## Using the custom button

Mode dial



### 1 Press AEL/☒.

- The monitor turns on and the function currently set to the custom button appears.

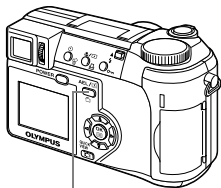

AEL/☒ AEL/Custom button

Ex: When DRIVE is set on the custom button

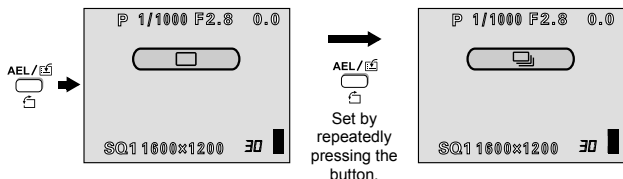

8

Useful functions



TIPS

**When ISO is set to the custom button but you want to use AE lock**

→ The AE lock function cannot be used when a different function is set to the custom button. Reset AE lock to the custom button by following "Setting the custom button" (P.131).



Note

- You cannot set the custom button separately in each mode.

# SHORT CUT

You can set three shortcut menus (A, B, C) on the top menu in a still picture shooting mode (except **AUTO**).

This is useful when you want to go quickly to frequently used functions.

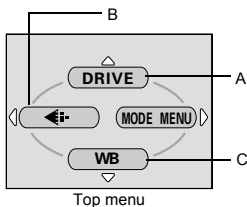

Default setting

A: DRIVE

B: ←

C: WB

Functions that can be set in the shortcut menu	Ref. Page	Functions that can be set in the shortcut menu	Ref. Page
DRIVE	P.83	PANORAMA	P.86
ISO	P.96	2 IN 1	P.88
A/S/M	P.63	FUNCTION	P.90
1/2/3/4	P.67	AF AREA	P.70
	P.62	INFO	P.141
SLOW	P.61		P.106
NOISE REDUCTION	P.105		P.91
MULTI METERING	P.76	WB	P.98
DIGITAL ZOOM	P.54		P.101
FULLTIME AF	P.69	SHARPNESS	P.102
AF MODE	P.68	CONTRAST	P.103
	P.81	SATURATION	P.104

## Setting the shortcut menu

You can set the three shortcut menus designated by A, B and C on the diagram shown right.

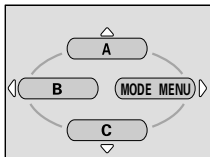

Mode dial



- 1** In the top menu, select **MODE MENU** → **SETUP** → **SHORT CUT**, and press

"How to use the menus" (P.33)

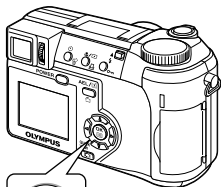

- 2** Press to select A, B or C, then press .

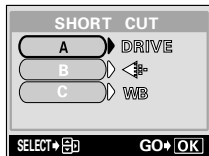

- 3** Press to select a function, then press .

- The shortcut menu is set.
- Press again to exit the menu.

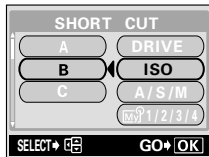

## Using the shortcut menu

When you have set a shortcut menu, you can use it to jump to the setting screen for that function.

Mode dial



### 1 Press to display the top menu.

- The shortcut menu you have set appears on the top menu.

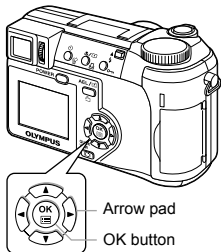

Arrow pad  
OK button

### 2 Press or to select the shortcut menu.

- The monitor jumps directly to the setting screen for that function.

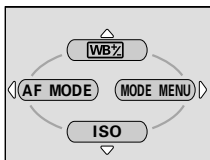

Ex: When **WB** is set in shortcut menu A

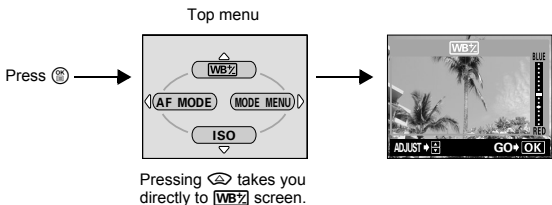

Note

- You cannot set the custom button separately in each mode.



You can set shooting-related functions in MY MODE. When the camera is in **P**, **A**, **S** or **M** mode, you can also save the current settings in MY MODE. When the mode dial is set to , your customized settings are activated. You can save up to 4 different settings in MY MODE 1 to 4. Only MY MODE 1 has a factory default setting.

## ●Functions affected by MY MODE SETUP

Functions that can be set in MY MODE	Default setting	Ref. Page	Functions that can be set in MY MODE	Default setting	Ref. Page
P/A/S/M/S-Prg	P	P.44	DIGITAL ZOOM	OFF	P.54
F No	F 2.8	P.64	FULLTIME AF	OFF	P.69
SHUTTER	1/1000	P.65	AF MODE	iESP	P.68
	±0	P.97		OFF	P.81
LCD *1	OFF	–	PANORAMA	OFF	P.86
ZOOM *2	38 mm	–	2 IN 1	OFF	P.88
FLASH MODE	AUTO	P.55	FUNCTION	OFF	P.90
	OFF	P.75, 80	INFO	OFF	P.141
	OFF	P.82		OFF	P.106
DRIVE		P.83		HQ	P.91
AF/MF	AF	P.73	WB	AUTO	P.98
ISO	AUTO	P.96		±0	P.101
	±0	P.62	SHARPNESS	±0	P.102
	SLOW1	P.61	CONTRAST	±0	P.103
NOISE REDUCTION	OFF	P.105	SATURATION	±0	P.104

\*1 This will set the monitor to ON or OFF when the camera is turned on.

\*2 In the mode, available zoom positions are 38 mm/50 mm/100 mm/200 mm and 380 mm (these numbers are based on the focal length of a 35 mm camera).

Mode dial



- 1 In the top menu, select **MODE MENU** → **SETUP** → **MY MODE SETUP**, and press .

"How to use the menus" (P.33)

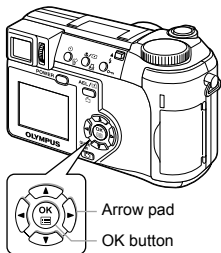

- 2 Press to select the type of setting, then press .

- PRESENT** Saves the current camera settings.
- RESET** Restores the factory default settings.
- CUSTOM** Saves settings one by one.

• The MY MODE SETUP screen appears.

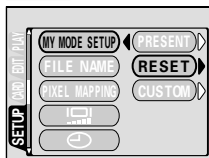

- 3 Select a **MY MODE** number.

• Press to select MY MODE number from 1 to 4, then press .

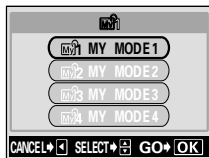

#### ●When selecting PRESENT in Step 2

- 4 Press to select **SET**, then press .

• The current camera settings are saved in the selected MY MODE.

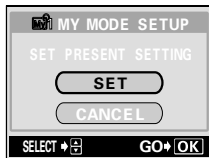

## ●When selecting RESET in Step 2

### 4 Press to select ALL RESET, then press .

- The settings in the selected MY MODE are reset.
- If no settings are saved, MY MODE settings cannot be selected.

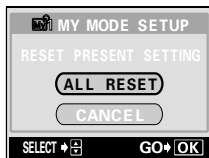

## ●When selecting CUSTOM in Step 2

### 4 Press to select the item you want to save in MY MODE, then press .

- For the available items, see "Functions affected by MY MODE SETUP" (P.136).

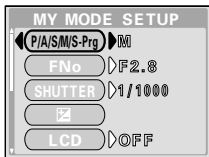

### Press to change the setting, then press .

- The setting is saved.
- You can also change the other custom settings.

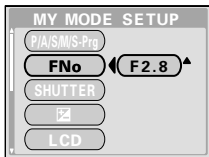

### 5 When you have made all the settings you want, press .

- The screen displayed in Step 2 appears.
- Press  again to exit the menu.



Note

- Although the settings you are using can be saved, the zoom position you are currently using may not be saved. The zoom position will be the closest of the 5 zoom settings in MY MODE to the position currently being used.

# CARD SETUP - Formatting Cards

This function lets you format a card. Formatting prepares cards to receive data. Before using non-Olympus cards or cards which have been formatted on a PC, you must format them with this camera.

All existing data, including protected pictures, are erased when the card is formatted. Make sure that you save or transfer important data to a PC before formatting a used card.

Mode dial



- 1 In the top menu, select **MODE MENU** → **CARD** → **CARD SETUP**, and press .

 "How to use the menu" (P.33)

- The  **FORMAT** screen is displayed.

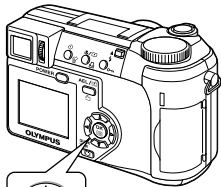



Mode dial

**AUTO**

In the top menu, press  to select **CARD SETUP**.

Mode dial



In the top menu, select **MODE MENU** → **CARD** → **CARD SETUP**, and press . Press   to select  **FORMAT**, then press .

## 2 Press to select YES, then press



- The **BUSY** bar is displayed and the card is formatted.

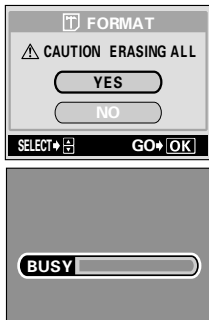

Never do the following during formatting, as they may cause the card to malfunction.

Note

- Open the card cover.
- Remove the battery.
- Connect or disconnect the AC adapter.

This function lets you display detailed shooting information on the monitor for approx. 3 seconds in the playback mode. For details of the information displayed, see “Viewfinder and monitor indications” (P.12).

**Mode dial**

- In the top menu, select **MODE MENU** → **CAMERA** → **INFO** → **ON** or **OFF**, and press .

“How to use the menus” (P.33)

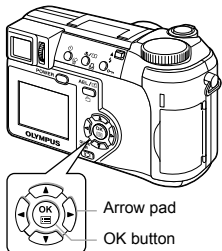
**Mode dial**

Pressing in the top menu displays the full amount of shooting information on the monitor (**ON**).

- To turn INFO off, press to display the top menu and press again.

Ex. Playback mode

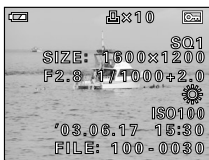

When INFO is ON



When INFO is OFF



Note

- If the picture has been taken with a different camera, setting INFO to ON in mode may still not display all the information.
- If is set, the histogram is displayed regardless of whether INFO is set to ON or OFF.

# Monitor/viewfinder brightness adjustment



This function lets you adjust the brightness of the monitor and viewfinder respectively.

Mode dial







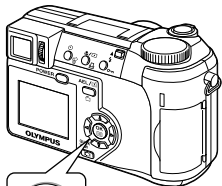

- 1 In the top menu, select **MODE MENU** → **SETUP** → , and press



 "How to use the menus" (P.33)



- 2 Press   to adjust the brightness while looking in the monitor or viewfinder, and when you have set the desired level, press .

- Pressing  brightens the monitor or viewfinder, and pressing  darkens it.
- Press  again to exit the menu.



# REC VIEW

You can choose whether or not to display the picture you have just taken on the monitor.

- ON** The picture being recorded to the card is displayed. This is useful for making a brief check of the picture you have just taken. Pressing the shutter button halfway during Rec View lets you resume shooting immediately.
- OFF** The picture being recorded to the card is not displayed. This is useful when you want to prepare for your next shot while the previous picture is being recorded.

## Mode dial



- 1 In the top menu, select **MODE MENU** → **SETUP** → **REC VIEW** → **OFF** or **ON**, and press .

 "How to use the menus" (P.33)

- Press  again to exit the menu.

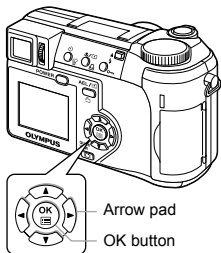



# SLEEP - Sleep Timer

The camera automatically enters the sleep mode and stops the operation when the preset time has elapsed with no operations performed. The camera activates again as soon as you touch the shutter button or arrow pad.

Mode dial



- 1 In the top menu, select **MODE MENU** → **SETUP** → **SLEEP** → **30 SEC**, **1 MIN**, **3 MIN**, **5 MIN** or **10 MIN**, and press

"How to use the menus" (P.33)

- Press again to exit the menu.

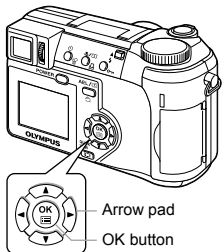

Note

- The sleep mode is not activated when using the AC adapter.
- In mode, the sleep mode is activated after 3 minutes regardless of the setting and the monitor turns off.
- If a slideshow lasts more than 30 minutes, the camera automatically enters the sleep mode and the monitor turns off.





You can turn off the beep sound used for button operations or warnings.

Mode dial



- 1 In the top menu, select **MODE MENU** → **SETUP** → **Beep** → **OFF**, and press .

 "How to use the menus" (P.33)

- Press  again to exit the menu.

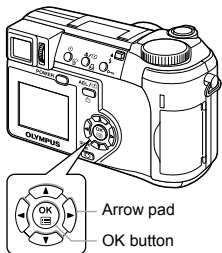

## POWER ON/OFF SETUP - Power on/off display setting

You can select a picture to be displayed when the power is turned on and off. It is also possible to register your favorite picture.  "SCREEN SETUP" (P.147)

**OFF** No picture is displayed.

- 1 Factory default setting
- 2 Selects a picture already registered. If there is no picture registered, nothing is displayed when the power is turned on or off.

Mode dial



- 1 In the top menu, select **MODE MENU** → **SETUP** → **PW ON/OFF SETUP** → **OFF**, **1** or **2**, and press



 "How to use the menus" (P.33)

- Press  again to exit the menu.

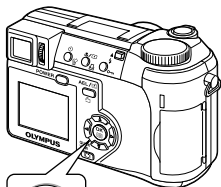

# SCREEN SETUP

You can register your favorite picture to be displayed when the power is turned on and off. The desired picture can be registered from the card. Make the **POWER ON/OFF SETUP** to display the registered picture.

☞ “POWER ON/OFF SETUP - Power on/off display setting” (P.146)

## Mode dial



### 1 In the top menu, select **MODE MENU** → **SETUP** → **SCREEN SETUP**, and press .

☞ “How to use the menus” (P.33)

- If a picture is already registered, the **IMAGE EXISTING** screen is displayed asking if you want to cancel the currently registered picture and register a new one. To register a new picture, select **RESET** and press . If you select **KEEP**, the screen returns to the menu.

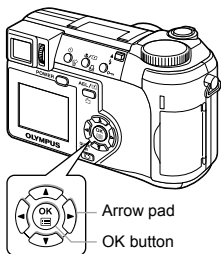

Arrow pad  
OK button

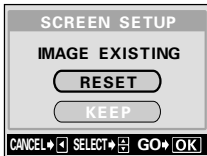

### 2 Select the picture you want to register using the arrow pad and press .

### 3 Press to select **OK**, then press .

- The picture is registered and the screen returns to the menu.
- Press again to exit the menu.

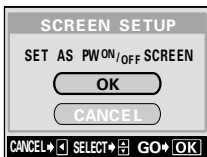

Note

- You cannot register pictures and movie frames that cannot be played back on this camera.

# FILE NAME

The camera automatically creates file names and folder names for images to be stored in. Files can be numbered from 0001 to 9999 and folders can be numbered from 100 to 999. Examples are shown below.

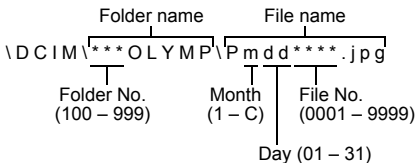

- Month: Jan. - Sep. = 1 - 9, Oct. = A, Nov. = B, Dec. = C

There are two settings from which you can choose: RESET or AUTO. Choose the one that is best for you when transferring images to a PC.

## File name settings

**RESET** The file number and folder number are reset every time a new card is inserted in the camera. The folder number returns to No. 100 and the file number returns to No. 0001. This method is useful when grouping files on separate cards.

**AUTO** Even if a new card is inserted, the folder number and file number are retained from the previous card, so the same file number is not used on different cards. This helps you to manage multiple cards. This method is useful when you want to manage all your files with sequential numbers.

8

Useful functions

### Mode dial



- 1 In the top menu, select **MODE MENU** → **SETUP** → **FILE NAME** → **RESET** or **AUTO**, and press .

"How to use the menus" (P.33)

- Press again to exit the menu.

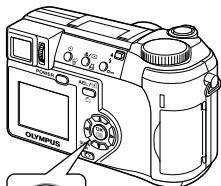



Note

- When the File No. reaches 9999, the file number returns to 0001 and the folder number changes.
- When both the Folder and File No. reach their respective maximum number (999/9999), the number of storable pictures becomes 0 even if the card is not full. No more pictures can be taken. Replace the card with a new one.

## PIXEL MAPPING

The Pixel Mapping feature allows the camera to check and adjust the CCD and image processing functions. It is not necessary to operate this function frequently. Approximately once a year is recommended. Wait a few minutes after the monitor is used or continuous shots are taken to allow for proper performance of the Pixel Mapping function.

Mode dial



- 1 In the top menu, select **MODE MENU** → **SETUP** → **PIXEL MAPPING**, and press

"How to use the menus" (P.33)

- START appears.

- 2 Press

- The **BUSY** bar is displayed during Pixel Mapping. When Pixel Mapping is finished, the screen returns to the mode menu.

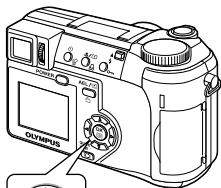

Arrow pad

OK button

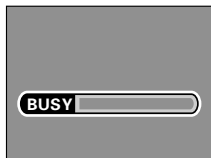



Note

- If you accidentally turn the camera off during Pixel Mapping, start again from Step 1.

## Measurement units

m/ft

The measurement unit can be selected from either meters or feet in the manual focus mode.

- m** At long ranges, the camera measures in meters, and at short ranges in centimeters.
- ft** At long ranges, the camera measures in feet, and at short ranges in inches.

Mode dial



- 1 In the top menu, select **MODE MENU** → **SETUP** → **m/ft** → **m** or **ft**, and press .

 "How to use the menu" (P.33)

- Press  again to exit the menu.

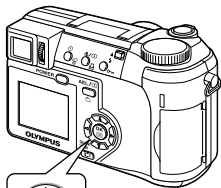

Arrow pad

OK button

# VIDEO OUT - Video output selection

You can select NTSC or PAL according to your TV's video signal type. Select the video signal type before connecting the video cable. If you select the wrong video signal type, you will not be able to play back the recorded pictures properly on the TV.

Mode dial



- 1 In the top menu, select **MODE MENU** → **SETUP** → **VIDEO OUT** → **NTSC or PAL**, and press

"How to use the menus" (P.33)

- Press again to exit the menu.
- The factory default setting varies depending on the area where you purchased this camera.

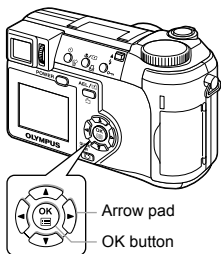

## TIPS

### TV video signal types & main regions

Check the video signal type before using the camera.

NTSC Japan, Taiwan, Korea, North America

PAL European countries, China



# 9 Print setting

## How to print pictures



Several different printing options are available when you want to print out pictures.

### ● **Printing at a photo lab that supports DPOF or printing on a DPOF-compatible printer**

Store the print reservation data on the card. Print reservation allows you to save printing data (number of prints, date/time information, etc.) with the pictures stored on the card.

- What is DPOF?

DPOF is short for Digital Print Order Format. DPOF is the format used to record automatic print information from digital cameras.

If a card containing print reservation data is taken to a photo lab that supports the DPOF format, the pictures can be printed according to the DPOF reservations. Or pictures can be printed out at home on a personal DPOF-compatible printer.

### ● **Printing on an Olympus CAMEDIA P-400 or P-200 digital printer**

Printing is possible directly from a card containing print reservation data without using a PC. For more details, refer to the printer's instruction manual. The xD-Picture Card cannot be inserted directly into the printer. Use the card adapter (sold separately).

### ● **Transferring pictures to a PC and printing them from a printer connected to the PC**

If your PC has software applications installed that support JPEG images (internet browser, Paint Shop Pro, Photoshop, etc.), you can print out your pictures on a printer connected to the PC. (Printing is also possible using CAMEDIA Master software.) Check your software before printing. For details, refer to the application software's instructions.

For instructions on how to transfer images, or connect the camera to a PC, see "DIGITAL CAMERA-PC CONNECTION OPERATION MANUAL" on the CD-ROM.



**TIPS****Picture size and printing**

The resolution of a computer/printer is generally based on the number of dots (pixels) per square inch. This is called dpi (dots per inch). The higher the dpi value, the better the printed results. Keep in mind, however, that the dpi of the picture does not change. This means that when you print an image with a higher resolution, the size of the printed picture will be smaller. Although you can print magnified images, picture quality will decrease.

If you want to print large, high-quality pictures, set the record mode as high as possible when taking the pictures.  "Record mode" (P.91)



Note

- DPOF reservations set by another device cannot be changed by this camera. Make changes using the original device.
- If a card contains DPOF reservations set by another device, entering reservations using this camera may overwrite the previous reservations.
- You may not be able to enter print reservations if there is insufficient memory space available on the card. (The "CARD FULL" message is displayed.)
- You can print up to 999 images from one card using the DPOF reservation function.
- Even if an image appears with the message "PICTURE ERROR", it may be possible to make print reservations. In this case, the print reservation icon () does not appear when an image is displayed for full view.  appears when multiple images are displayed (index display), allowing you to confirm the print reservation.
- Not all functions may be available on all printers or at all photo labs.
- Some TIFF images cannot be printed.
- Print reservation may take considerable time when saving printing data to a card.

# All-frame reservation



Use this feature to print all the pictures stored on the card. Select the desired number of prints and whether you want the date and time included.

## Mode dial



### 1 Play back a still picture.

- You cannot make the print reservation for pictures with

Print button

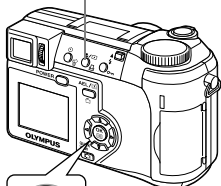

### 2 Press . The PRINT ORDER screen appears. Press to select , then press .

- If print reservation data is already stored on the card, the PRINT ORDER SETTING screen appears, giving you the choice of resetting the data or keeping it.

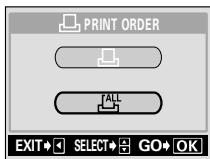

### 3 Press to select (number of prints) or (date/time), then press .

#### 4 Perform each setting as illustrated.

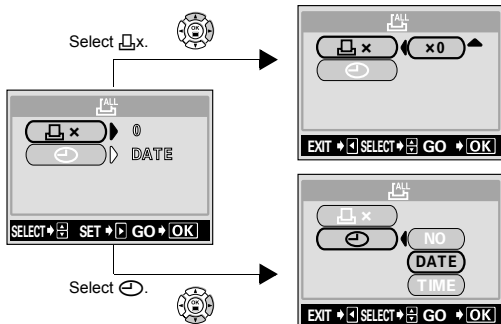

##### ●Set the number of prints

Press to set the number of prints, then press .

: Increases the number.

: Decreases the number.

##### ●Set the date/time printing data

Press to select NO, DATE or TIME, then press .

**NO** The pictures are printed without the date and time.

**DATE** All the pictures are printed with the shooting date.

**TIME** All the pictures are printed with the shooting time.

- After completing all the print reservations, press to return to the playback screen.

# Single-frame reservation



Use this feature to print only selected pictures. Display the picture to be printed and select the desired number of prints.

## Mode dial



### 1 Play back a still picture.

- You cannot make the print reservation for pictures with

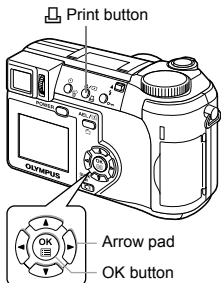

### 2 Press . The PRINT ORDER screen appears. Press to select , then press .

- If data is already stored on the card, the PRINT ORDER SETTING screen appears, giving you the choice of resetting the data or keeping it.

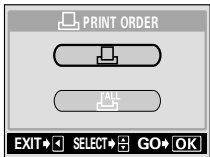

### 3 Select the frame you want to print using the arrow pad and press .



#### 4 Select the appropriate item using the arrow pad.

##### MORE

Sets the number of prints, date/time and trim size.  
→ Go to Step 5.

##### SINGLE PRINT

Sets single-frame print. The date/time and trimming settings are not available.  
→ Go to Step 8.

##### CANCEL

Cancels the print reservation for the displayed picture.  
☞ "Resetting print reservation data" (P.161)

##### END

Completes the print reservation.  
→ Go to Step 10.



Single-frame reservation menu

#### 5 Press to select x (number of prints), (date/time) or (trimming), then press .

#### 6 Perform each setting.

##### ●Set the number of prints

Press to set the number of prints, then press .

: Increases the number.

: Decreases the number.

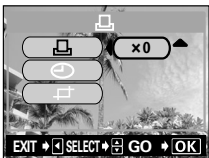
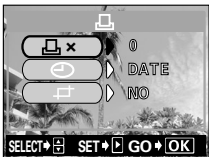

##### ●Set the date/time printing data

Press to select NO, DATE or TIME, then press .

**NO** The pictures are printed without the date and time.

**DATE** All the pictures with print reservation are printed with the shooting date.

**TIME** All the pictures with print reservation are printed with the shooting time.

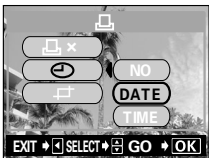

## ●Trim the picture

"Trimming" (P.159)

**7** After setting all the print reservations, press to complete the reservations.

- The screen in Step 3 is restored and appears on the displayed picture.



**8** Press to display the single-frame reservation menu.

**9** Press to select END.

- The PRINT ORDER screen appears.



**10** Press repeatedly until the playback screen appears.



This function enables you to crop part of a recorded picture and print out the enlarged section only.

## Mode dial



- 1 Press on the single-frame reservation screen to select (trimming) and press .

"Single-frame reservation" (P.156)

- If trimming has already been set, the screen appears. Press to select RESET, then press .



- 2 Use the arrow pad and zoom lever to decide the trimming position and size.

- Press to move the trimming frame.
- Use the zoom lever to decide the trimming size. The trimming frame changes from horizontal to vertical and vice versa when the maximum or minimum size is reached.

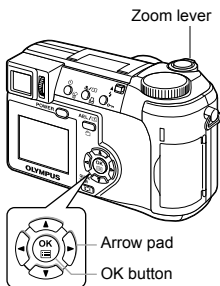

- 3 Press .







**4** Press  to select OK, then press .

**OK** Saves the current trimming size and returns to the single-frame reservation screen.



**RESET** Sets a new trimming size. →Go to Step 2.

**CANCEL** Cancels the current trimming setting and returns to the single-frame reservation screen.



**5** Press  to complete the print reservations and return to the picture selection screen. Press  again.

**6** Press  to select END.

- The  PRINT ORDER screen appears.
- Press  repeatedly until the playback screen appears.





Note

- The size of the printed picture varies depending on the printer settings. If the trimmed picture size is small, printing magnification increases accordingly, resulting in a printed picture with lower resolution.
- For best results with trimmed pictures, you are recommended to use the TIFF, SHQ or HQ mode.
- The original picture is not trimmed. If your printer does not have the trimming function, the picture will be printed untrimmed.
- Do not rotate pictures that have been trimmed, otherwise the cropped area will change.
- If images recorded in 3:2 are trimmed, the ratio is fixed at 4:3.

# Resetting print reservation data



This function allows you to reset the print reservation data for pictures stored on the card. There are two ways to reset print reservation: you can reset all print reservation data or you can reset the print reservation data for only the frames you do not need.



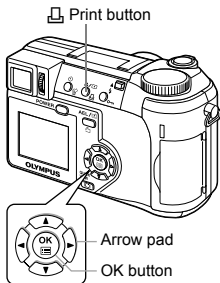



## Mode dial

- 1 Play back a still picture with .
- 2 Press .
  - If print reservation data is already stored on the card, the  PRINT ORDER SETTING screen appears.







- 3 To reset all print reservation data, press   to select RESET, then press . Press  to return to the playback screen.

To reset only the print reservation data for the frames that you do not need, press   to select KEEP, then press .

- If there is no print reservation data stored on the card, the  PRINT ORDER SETTING screen does not appear.
- 4 Press   to select  on the  PRINT ORDER screen, then press .





- 5** Press     to display the frame whose print reservation data you want to reset, then press .

- The single-frame reservation menu is displayed.



- 6** Press  to select CANCEL.

- Print reservation is canceled, and the screen in step 5 is restored.









- 7** If you are finished resetting print reservation data, press  to display the single-frame reservation menu. Press .



- 8** Press  repeatedly until the playback screen appears.

# 10 Miscellaneous

## Error codes

Monitor indication	Possible cause	Corrective action
 NO CARD	The card is not inserted, or it cannot be recognized.	Insert a card or insert a different card. Wipe the gold contacts with a commercially available cleaning paper and insert the card again. If the problem persists, format the card. If the card cannot be formatted, it cannot be used.
 CARD ERROR	There is a problem with the card.	Use a different card. Insert a new card.
 WRITE-PROTECT	Writing to the card is prohibited.	The recorded image has been protected (read-only) on a PC. Download the image to a PC and cancel the read-only setting.
 CARD FULL	The card is full. No more pictures, movies or information such as print reservation can be recorded.	Replace the card or erase unwanted pictures. Before erasing, download important images to a PC.
 NO PICTURE	There are no pictures on the card.	The card contains no pictures. Record pictures.
 PICTURE ERROR	The recorded image cannot be played back with this camera.	Use image processing software to view the picture on a PC. If that cannot be done, the image file is damaged.
 CARD COVER OPEN	The card cover is open.	Close the card cover.
	The card is not formatted.	Format the card.



# Troubleshooting



## ●The camera does not work







Possible cause	Corrective action	Ref. Page
<b>The camera does not turn on or function buttons do not respond.</b>		
The power is off.	Press the power switch and turn on the camera.	P.24
The batteries are loaded incorrectly.	Reload the batteries correctly.	P.18
The batteries are exhausted.	Replace the batteries with new ones.	P.15
The batteries are temporarily unable to function because of the cold.	Warm the batteries by putting them in your pocket for a while.	—
The camera is in the sleep mode.	Operate the camera (press the shutter button or the zoom lever).	P.24
There is condensation* inside the camera.	Wait until the camera dries before turning it on again.	—
The camera is connected to a PC.	The camera will not operate while it is connected to a PC.	—

\* Condensation: When it is cold outside, the water vapor in the air is rapidly cooled and turns to droplets of water. Condensation occurs when the camera is suddenly taken from a cold place into a warm room.

### **No picture is taken when the shutter button is pressed.**

The camera is in the playback mode.	Set the mode dial to any position except  .	P.42
The flash has not finished charging.	Remove your finger from the shutter button, and wait until the  (flash standby) indication stops blinking. Press the shutter button again.	P.57
The card is full.	Erase unwanted pictures or insert a new card. Before erasing, download important images to a PC.	P.22, 126
The batteries ran out of power during shooting or while the images were being written to the card. (Monitor turns off, or the battery check indicator blinks.)	Replace the batteries with new ones. (If images are being recorded on the card, wait until recording is finished.)	P.18

Possible cause	Corrective action	Ref. Page
The memory gauge is full.	Wait until there is room in the memory gauge.	P.15
There is a problem with the card.	Refer to "Error codes".	P.163
<b>The flash does not fire.</b>		
The flash is retracted.	Push the flash lever up to make the flash pop up.	P.55
The subject is illuminated.	If you want the flash to fire on a brightly illuminated subject, set the flash to fill-in mode.	P.55
Auto bracketing is set.	The flash does not fire in the auto bracketing mode. Set another mode in the DRIVE menu.	P.83
The camera is in the movie mode.	The flash does not fire in the movie mode. Set a different shooting mode.	P.51
FUNCTION is set to BLACK/WHITE BOARD.	The flash does not fire in the BLACK/WHITE BOARD mode.	P.90
Super macro mode is set.	The flash does not fire in the super macro mode. Set the super macro mode to OFF.	P.81
Panorama mode is set.	The flash does not fire in the panorama mode. Cancel the panorama mode.	P.86
<b>The viewfinder does not turn on.</b>		
The monitor is turned on.	Press  to switch to the viewfinder.	P.46
The camera is in the sleep mode.	Operate the camera (press the shutter button or the zoom lever).	P.24
<b>The monitor does not turn on.</b>		
The viewfinder is turned on.	Press  to turn the viewfinder off.	P.46
The camera is in the sleep mode.	Operate the camera (press the shutter button or the zoom lever).	P.24

Possible cause	Corrective action	Ref. Page
<b>The viewfinder or monitor is hard to see.</b>		
The diopter is not adjusted properly.	Adjust the diopter so that the AF target mark is clearly visible.	P.30
The brightness of the viewfinder or monitor is not adjusted properly.	Select  in the mode menu and adjust the brightness.	P.142
The monitor is exposed to direct sunlight.	Block the sunlight with your hand or use the viewfinder.	—
Vertical lines appear on the image in the viewfinder or monitor.	Bright light, such as direct sunlight, may cause vertical lines to appear on the image. This is not a malfunction.	—
<b>Pictures you have taken do not appear on the monitor.</b>		
The power is off.	Set the mode dial to  before pressing the power switch to turn the camera on.	P.108
The camera is in the shooting mode.	Press  twice quickly, or set the mode dial to  .	P.108, 109
There are no pictures on the card.	"NO PICTURE" appears on the monitor. Record pictures.	—
There is a problem with the card.	Refer to "Error codes".	P.163
The camera is connected to a TV.	The monitor does not function when the video cable is connected to the camera.	P.120
<b>The date recorded with the image data is wrong.</b>		
The date/time is not set.	Set the date/time. The clock adjustment is not factory-preset.	P.28
The batteries are exhausted.	When the batteries run out, the date/time setting may be canceled. Replace the batteries with new ones and set the date/time again.	P.18, 28
The camera has been left with the batteries removed.	If the camera is left for several hours with the batteries removed, the date/time setting is canceled. Set the date/time again.	P.18, 28
<b>Single-frame erase or all-frame erase cannot be performed.</b>		
The picture you want to erase is protected.	Display the protected image (with  ) and press  to cancel the protection.	P.125

Possible cause	Corrective action	Ref. Page
The settings are returned to the factory default settings when the camera is turned off.		
ALL RESET is set to ON.	Select the SETUP tab in the mode menu and set ALL RESET to OFF.	P.128
No picture is displayed on the TV when connected to the camera.		
The video output signal is incorrect.	Set the video output signal according to the region where used.	P.151
The camera is not in the playback mode.	Set the mode dial to any position except  .	P.120
The TV video signal setting is incorrect.	Set the TV to the video input mode.	P.120



●The image quality is poor.







Possible cause	Corrective action	Ref. Page
<b>The picture is too bright.</b>		
The flash was set to the fill-in flash mode.	Select a flash mode other than fill-in flash.	P.55
The subject was excessively illuminated.	Adjust the exposure compensation toward minus (-) or change the camera position.	P.97
<b>The picture is too dark.</b>		
The flash was blocked by your finger.	Hold the camera correctly, keeping your fingers away from the flash.	P.31
The subject was out of the working range of the flash.	Shoot within the flash working range.	P.56
The flash was not enabled.	Push the flash lever up to make the flash pop up.	P.55
The subject was too small and was backlit.	Set the flash to fill-in mode, or use the spot metering mode.	P.55, 75
The sequential shooting mode was used.	Higher shutter speeds are used when the sequential shooting mode is selected, which may result in pictures that are darker than usual. Select <input type="checkbox"/> in the DRIVE menu.	P.83
When shooting a bright subject such as a landscape, the picture comes out darker than the actual colors.	Adjust the exposure compensation toward plus (+).	P.97
<b>The colors of pictures taken indoors look unnatural.</b>		
Indoor lighting can affect the picture's colors.	Set the white balance according to the lighting.	P.98
No white in frame.	Include something white in the picture, or shoot using the fill-in flash mode.	P.55
The white balance setting is wrong.	Adjust the white balance according to the light source.	P.98

Possible cause	Corrective action	Ref. Page
<b>The picture has obscured edge(s).</b>		
The lens was partly blocked by your finger or the strap.	Hold the camera correctly, keeping your fingers and the strap away from the lens.	P.31
<b>The picture is out of focus.</b>		
The camera moved when the shutter button was pressed.	Hold the camera correctly and press the shutter button gently.	P.31
The subject was too close.	Move further away from the subject. To take pictures closer than 7 cm (2.8") with the zoom in the maximum WIDE position, use the super macro mode.	P.80, 81
The flash was not enabled in a lighting condition requiring use of the flash.	Push the flash lever up to make the flash pop up. Camera movement occurs easily with slower shutter speeds. Use a tripod, or hold the camera firmly.	P.55
The lens was dirty.	Clean the lens. Use a commercially available blower brush and then wipe with a lens cleaner to remove dust. Mold may form on the lens surface if the lens is left dirty.	P.183
The picture was out of focus even though the green lamp was lit.	Focus the camera on an object at the same distance as the intended subject using the focus lock function before composing your shot.	P.49
<b>Halation produces unnatural colors in the picture.</b>		
This may be caused by excessively bright ultraviolet light on the subject, such as sunlight shining through the leaves of trees, window frames in bright light at night, reflection of metal in direct sunlight, etc.	<ul style="list-style-type: none"> <li>• Use a UV filter. As this may upset the overall color balance, it should only be used in the conditions described on the left.</li> <li>• Process the picture on a PC using a graphics application (Photoshop, Paint Shop Pro, etc.). For example, after picking up unnatural colors with a syringe tool, etc. you can select color areas, and try color conversion or saturation adjustment. For details, refer to the manual for the graphics application you are using.</li> </ul>	—

Possible cause	Corrective action	Ref. Page
<b>The batteries soon run down.</b>		
The camera is being used in a cold environment.	Battery performance deteriorates in low temperatures. Keep the camera warm by putting it inside your coat or clothing.	—
The camera misread the remaining battery power.	When the power consumption fluctuates greatly, the camera may turn off without displaying the low battery warning. Replace with new batteries.	P.15

# List of menus

## ● **AUTO** mode

Top menu	Setting	Ref. Page
DRIVE	 ,  , <b>HI</b>  , <b>AF</b>  , BKT	P.83
	SHQ 2048 × 1536, HQ 2048 × 1536, SQ1 1280 × 960, SQ2 640 × 480	P.91
		P.28
CARD SETUP	YES, NO	P.139

## A/S/M/Pmode

Top menu	Tab	Function	Setting	Ref. Page	
MODE MENU	CAMERA	DRIVE*1	HI  , AF  , BKT*5	P.83	
		ISO	AUTO, 100, 200, 400	P.96	
		A/S/M*2	A, S, M	P.63	
		1/2/3/4*3	MY MODE 1 – MY MODE 4	P.67	
			-2.0 – +2.0	P.62	
		SLOW	SLOW1, SLOW1, SLOW2	P.61	
		NOISE REDUCTION*4	OFF, ON	P.105	
		MULTI METERING*5	OFF, ON	P.76	
		DIGITAL ZOOM*6	OFF, ON	P.54	
		FULLTIME AF	OFF, ON	P.69	
		AF MODE	iESP, SPOT	P.68	
		*6	OFF, ON	P.81	
		PANORAMA*7		P.86	
		2 IN 1		P.88	
		FUNCTION	OFF, BLACK & WHITE, SEPIA, WHITE BOARD, BLACK BOARD	P.90	
		AF AREA		P.70	
		INFO	OFF, ON	P.141	
		*5	OFF, ON	P.106	
		PICTURE		TIFF, SHQ, HQ, SQ1, SQ2	P.91
			WB	AUTO, PRESET, 	P.98
				-7 – +7	P.101
			SHARPNESS	-5 – +5	P.102
			CONTRAST	-5 – +5	P.103
	CARD	SATURATION	-5 – +5	P.104	
		CARD SETUP	YES, NO	P.139	

To the next page

**A/S/M/P mode (cont.)**

Top menu	Tab	Function	Setting	Ref. Page
MODE MENU	— SETUP	ALL RESET* <sup>8</sup>	OFF, ON	P.128
			ENGLISH, FRANCAIS, DEUTSCH, ESPAÑOL,	P.26
		PW ON/OFF SETUP	OFF, 1, 2	P.146
		REC VIEW	OFF, ON	P.143
		SLEEP	30 SEC, 1 MIN, 3 MIN, 5 MIN, 10 MIN	P.144
		MY MODE SETUP	PRESENT, RESET, CUSTOM	P.136
		FILE NAME	RESET, AUTO	P.148
		PIXEL MAPPING		P.149
				P.142
				P.28
		m/ft	m, ft	P.150
		VIDEO OUT	NTSC, PAL	P.151
		SHORT CUT	A, B, C	P.133
		CUSTOM BUTTON		P.130
			OFF, ON	P.145
(DRIVE)				Functions set as shortcuts
(WB)				

\*1 Not available in mode.

\*2 Only available in **A/S/M** modes.

\*3 Only available in mode.

\*4 Not available in modes.









\*5 Not available in **M** mode.

\*6 Not available in mode.









\*7 Not available in **A/S/M** modes.

\*8 Not available in mode.

 mode





Top menu	Tab	Function	Setting	Ref. Page
MODE MENU	CAMERA	ISO	AUTO, 100, 200, 400	P.96
		FULLTIME AF	OFF, ON	P.69
		 AF-ON	OFF, ON	P.81
		FUNCTION	OFF, BLACK & WHITE, SEPIA	P.90
	PICTURE	 WB	-7 - +7	P.101
		SHARPNESS	-5 - +5	P.102
		CONTRAST	-5 - +5	P.103
		SATURATION	-5 - +5	P.104
	CARD	CARD SETUP	YES, NO	P.139
	SETUP	ALL RESET	OFF, ON	P.128
			ENGLISH, FRANCAIS, DEUTSCH, ESPAÑOL,	P.26
		PW ON/OFF SETUP	OFF, 1, 2	P.146
		FILE NAME	RESET, AUTO	P.148
		PIXEL MAPPING		P.149
				P.142
				P.28
		VIDEO OUT	NTSC, PAL	P.151
			OFF, ON	P.145
	DIGITAL ZOOM		OFF, ON	P.54
		HQ, SQ	P.91	
WB		AUTO, PRESET, 	P.98	

●  mode (still pictures)

Top menu	Tab	Function	Setting	Ref. Page
MODE MENU	EDIT		640 × 480, 320 × 240, CANCEL	P.122
			NEW FILE, CANCEL	P.123
	CARD	CARD SETUP	ALL ERASE, FORMAT	P.127, 139
	SETUP	ALL RESET	OFF, ON	P.128
			ENGLISH, FRANCAIS, DEUTSCH, ESPAÑOL,	P.26
		PW ON/OFF SETUP	OFF, 1, 2	P.146
		SCREEN SETUP		P.147
				P.142
				P.28
		VIDEO OUT	NTSC, PAL	P.151
			4, 9, 16	P.112
			OFF, ON	P.145
				P.113
	INFO		P.141	
		P.106		





















●  mode (movies)



Top menu	Tab	Function	Setting	Ref. Page
MODE MENU	CARD	CARD SETUP	ALL ERASE, FORMAT	P.127, 139
		SETUP	ALL RESET	OFF, ON
			ENGLISH, FRANCAIS, DEUTSCH, ESPAÑOL,	P.26
	PW ON/OFF SETUP		OFF, 1, 2	P.146
				P.142
				P.28
	VIDEO OUT		NTSC, PAL	P.151
			4, 9, 16	P.112
			OFF, ON	P.145
	MOVIE PLAY		MOVIE PLAYBACK	PLAYBACK, FRAME BY FRAME, EXIT
INDEX			OK, RESET, CANCEL	P.116
EDIT			OK, RESET, CANCEL	P.118
INFO				P.141

# List of factory default settings





The functions are set as follows when the camera leaves the factory.

## ● Shooting mode





F No.	F2.8
SHUTTER	1/1000 sec.
ZOOM	WIDE
LCD	OFF
	±0
FLASH	AUTO (S, M:  SLOW1,  :  )
	OFF
AF/MF	AF
	OFF
DRIVE	
BKT	±1 EV, 3
ISO	AUTO (A, S, M: 100)
<b>A/S/M</b>	A
 1/2/3/4	MY MODE 1
	±0
 SLOW	 SLOW1
NOISE REDUCTION	OFF (  : fixed on ON)
MULTI METERING	OFF
DIGITAL ZOOM	OFF
FULLTIME AF	OFF (  : ON)
AF MODE	iESP (  : fixed on iESP)
	OFF
PANORAMA	OFF
2 IN 1	OFF
FUNCTION	OFF
AF AREA	CENTER
INFO	OFF
	OFF
	HQ (2048 × 1536,  : 320 × 240)

TIFF	2048 × 1536
SHQ	2048 × 1536
HQ	2048 × 1536
SQ1	1280 × 960 NORMAL
SQ2	640 × 480 NORMAL
WB	AUTO
	±0
SHARPNESS	±0
CONTRAST	±0
SATURATION	±0
REC VIEW	ON
SLEEP	3 MIN
FILE NAME	RESET
m/ft	m
SHORT CUT	A: DRIVE, B:  C: WB
CUSTOM BUTTON	AE LOCK

### ●Playback mode

INFO	OFF
	OFF
	OFF
	0°
	OFF
	9

## ●Others

ALL RESET	ON
 ENGLISH	ENGLISH
PW ON/OFF SETUP	1
 NORMAL	NORMAL
 Y-M-D 2003.01.01 00:00	Y-M-D 2003.01.01 00:00
VIDEO OUT	*
 ON	ON







\* Settings differ according to the region where the camera is sold.

# Modes and Shooting Functions

In **My** mode, available functions vary depending on the modes set in the MY MODE SETUP menu.

Function		Mode	AUTO		A/S/M			P	
					A	S	M		
<b>A/S/M</b>			—		✓			—	
Zoom					✓				
DIGITAL ZOOM			—		✓*1				
AF					✓				
Focus lock					✓				
AF MODE			—		✓			—	
FULLTIME AF			—		✓				
AF AREA			—		✓			—	
Manual focus			—		✓			—	
FLASH MODE	AUTO			✓		—	✓	—	
				✓		—	✓	—	
		—		✓		—	✓	—	
	SLOW1	—			✓			—	
	SLOW	—		✓		—	✓	—	
	SLOW2	—			✓			—	
					✓				
	—			✓			—		
SLOW	—			✓			—		
	—			✓			—		
MULTI METERING			—	✓		—	✓	—	
AEL			—		✓			—	
AF lock			—		✓			—	
					✓				
		—			✓*1				
					✓				

Function	Mode	A/S/M			P		
	<b>AUTO</b>		A	S			M
		√*2					—
<b>BKT</b>	—	√*2			—	✓	—
PANORAMA	—	√*1	—		✓	—	
2 IN 1	—	✓				—	
FUNCTION	BLACK&WHITE	—	✓				—
	SEPIA	—	✓				—
	WHITE BOARD	—	✓				—
	BLACK BOARD	—	✓				—
		✓					—
ISO	—	✓					—
	—	✓	—		✓	—	
WB	—	✓					—
	—	✓					—
SHARPNESS	—	✓					—
CONTRAST	—	✓					—
SATURATION	—	✓					—
NOISE REDUCTION	—	✓			—		—
INFO	—	✓					—
	—	✓	—		✓	—	
ALL RESET	—	√*3					—
	—	✓					—
PW ON/OFF SETUP	—	✓					—
REC VIEW	—	✓					—
SLEEP	—	✓					—
MY MODE SETUP	—	✓					—

Function \ Mode	AUTO	  	A/S/M			P	
			A	S	M		
FILE NAME	—		✓				
PIXEL MAPPING	—		✓				
	—		✓				
			✓				
m/ft	—		✓				—
VIDEO OUT	—		✓				
SHORT CUT	—		✓				—
CUSTOM BUTTON	—		✓				—
	—		✓				

✓ : Available — : Not available

\*1 Cannot be selected in  mode.

\*2 Cannot be selected in  mode.

\*3 Cannot be selected in  mode.

# Camera maintenance

## ●After use

Turn off the power and fit the lens cap on the lens.

If you are not going to use the camera for a long time, remove the batteries.

## ●Cleaning the camera

**1 Turn off the camera.**  P.24

**2 Remove the batteries.**  P.18 (If you are using an AC adapter, unplug the AC adapter from the camera first before removing the plug from the AC outlet.)

**3 Exterior:**

→ Wipe gently with a soft cloth. If the camera is very dirty, soak the cloth in mild soapy water and wring well. Wipe the camera with the damp cloth and then dry it with a dry cloth. If you have used the camera at the beach, use a cloth soaked in clean water and well wrung.

**Monitor and viewfinder:**

→ Wipe gently with a soft cloth.

**Lens:**

→ Blow dust off the lens with a commercially available blower, then wipe gently with a lens cleaning paper.

**Card:**

→ Wipe gently with a soft, dry cloth.



Note

- Do not use strong solvents such as benzene or alcohol, or chemically treated cloth.
- Cleaning should be done only after the batteries have been removed or the AC adapter has been disconnected.
- Mold may form on the lens surface if the lens is left dirty.



# Specifications

Product type	: Digital camera (for shooting and displaying)
Recording system	
Still picture	: Digital recording, TIFF (non-compression), JPEG (in accordance with Design rule for Camera File system (DCF)), Exif 2.2, Digital Print Order Format (DPOF), and Print Image Matching II
Movie	: QuickTime Motion JPEG support
Memory	: xD-Picture Card (16 – 256 MB)
Resolution	: 3200 × 2400 pixels (ENLARGE SIZE: SHQ, HQ) 2048 × 1536 pixels (TIFF, SHQ, HQ) 2048 × 1360 pixels (3:2 TIFF, SHQ, HQ) 1600 × 1200 pixels (TIFF, SQ1) 1280 × 960 pixels (TIFF, SQ1) 1024 × 768 pixels (TIFF, SQ2) 640 × 480 pixels (TIFF, SQ2)
No. of storable pictures	
(When using a 32 MB card)	: Approx. 3 frames (TIFF: 2048 × 1536) Approx. 16 frames (SHQ: 2048 × 1536) Approx. 40 frames (HQ: 2048 × 1536) Approx. 99 frames (SQ1: 1280 × 960 NORMAL) Approx. 331 frames (SQ2: 640 × 480 NORMAL)
No. of effective pixels	: 3,200,000 pixels
Image pickup device	: 1/2.5" CCD solid-state image pickup, 3,340,000 pixels (gross)
Lens	: Olympus lens 6.3 mm to 63 mm, f2.8 to f3.7, 11 elements in 7 groups (equivalent to 38 mm to 380 mm lens on a 35 mm camera)
Photometric system	: Digital ESP metering, Spot metering system
Aperture	: f2.8 to f8.0
Shutter speed	: 16 to 1/1000 sec.
Shooting range	: 0.6 m to ∞ (W), 2 m to ∞ (T) (NORMAL) 0.07 m to ∞ (W), 1.2 m to ∞ (T) (macro mode)
Viewfinder	: 0.44" TFT color LCD display, 180,000 pixels
Monitor	: 1.5" TFT color LCD display, 114,000 pixels

Auto focus	: TTL system autofocus Contrast detection system
Outer connector	: DC-IN jack, USB connector (mini-B), Video OUT jack
Automatic calendar system	: Up to 2099
Operating environment	
Temperature	: 0°C to 40°C (32°F to 104°F) (operation) -20°C to 60°C (-4°F to 140°F) (storage)
Humidity	: 30% to 90% (operation)/10% to 90% (storage)
Power supply	: 2 CR-V3 lithium battery packs, or 4 AA (R6) alkaline batteries, lithium batteries, NiMH batteries or NiCd batteries. AC adapter (optional) Manganese (zinc-carbon) batteries cannot be used.
Dimensions	: 107.5 mm (W) × 66 mm (H) × 68.5 mm (D) (4.2" × 2.6" × 2.7") (excluding protrusions)
Weight	: 295 g (0.6 lb.) (without batteries or card)

SPECIFICATIONS ARE SUBJECT TO CHANGE WITHOUT ANY NOTICE OR OBLIGATION ON THE PART OF THE MANUFACTURER.

# Glossary of terms

## **A (Aperture Priority) Mode**

You set the aperture yourself and the camera automatically varies the shutter speed so that the picture is taken with the best exposure.

## **AE (Automatic Exposure)**

The camera automatically sets the exposure. The 3 AE modes available on this camera are **P** mode, in which the camera selects both the aperture and shutter speed, **A** mode, in which the user selects the aperture and the camera sets the shutter speed, and **S** mode, in which the user selects the shutter speed and the camera sets the aperture.

In **M** mode, the user selects both the aperture and the shutter speed.

## **Aperture**

The adjustable lens opening which controls the amount of light that enters the camera. The larger the aperture, the shorter the depth of field and the fuzzier the background. The smaller the aperture, the greater the depth of field and the sharper the background. Aperture is measured in f/stops. Larger aperture values indicate smaller apertures, and smaller aperture values indicate larger apertures.

## **CCD (Charge-Coupled Device)**

This converts light passing through the lens into electrical signals. On this camera, light is picked up and converted into RGB signals to build a single image.

## **Contrast Detection Method**

This is used to measure the distance to the subject. The camera determines if the image is focused by the level of contrast in the subject.

## **Conventional Photograph**

This refers to recording images using silver halide (the method for recording images in conventional, non-digital photography). This system is in contrast to still video and digital photography.

## **DCF (Design rule for Camera File system)**

A standard for image files by the Japan Electronics and Information Technology Industries Association (JEITA).

## **Digital ESP (Electro-Selective Pattern) Light Metering**

This determines the exposure by metering and calculating the light levels in the center and other areas of the image separately.

**DPOF (Digital Print Order Format)**

This is for saving desired print settings on digital cameras. By entering which images to print and the number of copies of each, the user can easily have the desired images printed by a printer or print lab that supports the DPOF format.

**Eclipsing (Vignetting)**

This refers to when an object obscures part of the field of view so that the whole subject is not photographed. Vignetting also refers to when the image seen through the viewfinder does not exactly match the image shot through the objective lens, so the photographed image includes objects not seen through the viewfinder. In addition, vignetting can occur when an incorrect lens hood is used, causing shadowing to appear in the corners of the image.

**Effective Pixel Resolution**

The number of pixels used in the CCD to create the image.

**EV (Exposure Value)**

A system for measuring exposure. EV0 is when the aperture is at F1 and the shutter speed is 1 second. The EV then increases by 1 each time the aperture increases by one F stop or the shutter speed increases by one increment. EV can also be used to indicate brightness and ISO settings.

**Exposure**

The amount of light used to capture an image. The exposure is determined by the time the shutter is open (shutter speed) and the amount of light that passes through the lens (aperture).

**Gross Pixel Resolution**

The total number of pixels in a CCD. Not all pixels are used to create the image.

**ISO**

A method for indicating film speed by the International Organization for Standardization (ISO) (e.g. "ISO100"). Higher ISO values indicate greater sensitivity to light, so images can be exposed even in low-light conditions.

## **JPEG (Joint Photographic Experts Group)**

A compression format for color still images. Photographs (images) shot using this camera are recorded onto the card in JPEG format when the Record mode is set to SHQ, HQ, SQ1 or SQ2. By downloading these images to a personal computer, users can edit them using graphics application software or view the images using an Internet web browser.

## **M (Manual) Mode**

The user sets both the aperture and shutter speed.

## **NTSC (National Television Systems Committee) / PAL (Phase Alternating Line)**

Television formats. NTSC is mainly used in Japan, North America and Korea. PAL is mainly used in Europe and China.

## **P (Program) Mode**

Also called Program AE mode. The camera automatically sets the best shutter speed and aperture for the shot.

## **Pixels**

A pixel is the smallest unit (dot) used to make up an image. Clear large-sized printed images require millions of pixels.

## **S (Shutter Priority) Mode**

Also called Shutter Priority AE mode. The user selects the shutter speed and the camera automatically varies the aperture so that the picture is taken with the best exposure.

## **Sleep Mode**

A mode designed to save battery life. The camera automatically enters the sleep mode if you do not operate it for a certain time. To get out of the sleep mode, use any button on the camera (shutter button, arrow pad, etc.).

## **TIFF (Tagged Image File Format)**

An uncompressed format used for saving highly detailed black and white or color image data. TIFF image files can be handled by software programs for scanners and graphics applications.













## **TFT (Thin-Film Transistor) Color Monitor**

A color monitor constructed using thin-film transistor.





















## **TTL (Through-The taking-Lens) System**

To help adjust exposure, a light receptor built into the camera directly measures the light passing through the lens.

# Index

- 3:2 ..... 95
- A**
- AC adapter ..... 20
- AE lock **AEL** ..... 78
- AE memory **MEMO** ..... 79
- AEL/custom button  
    **AEL** /  ..... 76, 78, 130
- AF AREA ..... 70
- AF lock ..... 71
- AF MODE ..... 68
- AF sequential  
    shooting **AF**  ..... 83
- AF target mark ..... 46, 70
- Alkaline battery ..... 20
- ALL RESET ..... 128
- All-frame erase  ..... 127
- All-frame reservation ..... 154
- Aperture priority  
    shooting **A** ..... 44, 64
- Aperture value ..... 64
- Arrow pad ..... 11, 32, 108
- Auto bracketing **BKT** ..... 84
- Auto flash ..... 58
- Auto focus ..... 50
- Auto white balance ..... 98
- B**
- Batteries ..... 18
- Battery check ..... 15
- Battery compartment cover .. 11, 18
- Battery compartment lock .. 11, 18
- Beep sound  ..... 145
- BKT ..... 84
- BLACK & WHITE ..... 90
- BLACK BOARD ..... 90
- C**
- Camera movement warning .... 57
- Card ..... 22
- Card access lamp ..... 11, 46
- Card check ..... 25
- Card cover ..... 11, 22
- CARD SETUP ..... 139
- Close-up playback  ..... 110
- Cloudy day  ..... 99
- Connector cover ..... 10, 120
- CONTRAST ..... 103
- CUSTOM BUTTON ..... 130
- D**
- Date/time setting  ..... 28
- DC-IN jack ..... 10, 20
- DIGITAL ZOOM ..... 54
- Diopter adjustment dial ..... 30
- DPOF ..... 152
- DRIVE ..... 83
- E**
- Editing movies ..... 116
- ENLARGE SIZE ..... 95
- Erasing pictures ..... 126
- Error codes ..... 163
- ESP metering ..... 75
- Exposure compensation  ..... 97
- Exposure differential ..... 66
- F**
- FILE NAME ..... 148
- File number ..... 148
- Fill-in flash  ..... 58
- Flash ..... 55
- Flash charge ..... 12, 57
- Flash intensity control  ..... 62
- Flash mode ..... 55
- Flash mode button  ..... 55
- Flash off  ..... 59
- Flash stand-by ..... 12, 57
- Fluorescent lamp  ..... 99
- Focus lock ..... 49

- Formatting . . . . . 139  
 Front curtain **SLOW1** . . . . . 59  
 Front curtain with red-eye reduction  
      **SLOW1** . . . . . 60  
 Full-auto shooting **AUTO** . . . . . 42  
 FULLTIME AF . . . . . 69  
 Fully pressed . . . . . 47  
 FUNCTION . . . . . 90
- G**
- Green lamp . . . . . 47
- H**
- Halfway pressed . . . . . 47  
 High quality . . . . . 92  
 High speed sequential  
     shooting **HI** . . . . . 83  
 Histogram display . . . . . 106  
 HQ . . . . . 91
- I**
- iESP . . . . . 68  
 Index (Creating an index) . . . . . 116  
 Index display . . . . . 111  
 Information display **INFO** . . . . . 141  
 ISO sensitivity . . . . . 96
- L**
- Landscape shooting . . . . . 43  
 Landscape+Portrait  
     shooting . . . . . 43  
 Language setting . . . . . 26  
 Lens . . . . . 10  
 Lens cap . . . . . 17  
 Lens cap string . . . . . 17  
 Lithium battery pack . . . . . 20
- M**
- Macro/spot  
     button / . . . . . 75, 80  
 Macro mode shooting . . . . . 80  
 Manual focus . . . . . 73  
 Manual shooting **M** . . . . . 45, 66  
 Measurement units **m/ft** . . . . . 150  
 Memory gauge . . . . . 15  
 Metering . . . . . 75  
 Mode . . . . . 42  
 Mode dial . . . . . 42  
 MODE MENU . . . . . 32  
 Monitor . . . . . 46, 108  
 Monitor/viewfinder brightness  
     adjustment . . . . . 142  
 Monitor button . . . . . 46, 109  
 Movie . . . . . 51  
 MOVIE PLAY . . . . . 114  
 MULTI METERING . . . . . 76  
 MY MODE SETUP . . . . . 136  
 My mode shooting . . . . . 67
- N**
- Night scene shooting . . . . . 43  
 NiMH battery . . . . . 20  
 NOISE REDUCTION . . . . . 105  
 No. of storable still pictures . . . . . 92  
 Normal quality . . . . . 92  
 NTSC . . . . . 151, 188
- O**
- OK/Menu button . . . . . 11, 32  
 One-touch white balance . . . . . 99  
 Optical zoom . . . . . 53
- P**
- PAL . . . . . 151, 188  
 PANORAMA . . . . . 86  
 Picture rotation . . . . . 121  
 PIXEL MAPPING . . . . . 149  
 Playback mode . . . . . 14

- Playing back movies ..... 114  
 Playing back pictures  
     on a TV ..... 120  
 Portrait shooting  ..... 42  
 Power switch ..... 24  
 Preset white balance ..... 99  
 Print button  ..... 154  
 Print reservation ..... 154, 156  
 Program shooting **P** ..... 44  
 Protect button  ..... 125  
 Protecting ..... 125  
 PW ON/OFF SETUP ..... 146
- Q**
- QUICK VIEW ..... 109
- R**
- Rear curtain  **SLOW2** ..... 60  
 REC VIEW ..... 143  
 Rechargeable batteries ..... 20  
 Recording movies  ..... 51  
 Red-eye reduction flash  ..... 58  
 Resizing  ..... 122  
 Resolution ..... 92  
 Rotation button  ..... 121
- S**
- SATURATION ..... 104  
 SCREEN SETUP ..... 147  
 Seconds remaining ..... 51  
 Self-portrait shooting  ..... 43  
 Self-timer  ..... 82  
 Self-timer button  ..... 11, 82  
 Self-timer lamp ..... 10, 82  
 SEPIA ..... 90  
 Sequential shooting  ..... 83  
 SHARPNESS ..... 102  
 Shooting mode ..... 12  
 Shooting mode menu ..... 42  
 SHORT CUT ..... 133
- SHQ ..... 91  
 Shutter button ..... 10, 47  
 Shutter priority shooting **S** ..... 44, 65  
 Shutter speed ..... 65  
 Single-frame erase  ..... 126  
 Single-frame playback ..... 108  
 Single-frame reservation ..... 156  
 Single-frame shooting ..... 46, 83  
 SLEEP ..... 144  
 Slideshow  ..... 113  
 Slow synchronization  
      **SLOW** ..... 59, 61  
 Specifications ..... 184  
 Sports shooting  ..... 42  
 Spot metering  ..... 75  
 SQ ..... 91  
 Strap ..... 17  
 Strap eyelet ..... 10, 17  
 Sunny day  ..... 99  
 Super macro mode  
     shooting  ..... 81
- T**
- TIFF ..... 91  
 Top menu ..... 32  
 Trimming  ..... 123  
 Tripod socket ..... 11  
 Troubleshooting ..... 164  
 Tungsten light  ..... 99  
 Two-in-one pictures **2 IN 1** ..... 88
- U**
- USB connector ..... 10
- V**
- Video OUT jack ..... 10, 120  
 VIDEO OUT ..... 151  
 Viewfinder ..... 11, 30



**W**

White balance <b>WB</b> .....	98
White balance adjustment	
 .....	101
WHITE BOARD.....	90

**X**

xD-Picture Card.....	22
----------------------	----

**Z**

Zoom lever .....	54, 110, 111
------------------	--------------

# OLYMPUS

<http://www.olympus.com/>

## OLYMPUS OPTICAL CO., LTD.

Customer support (Japanese language only): Tel. 0426-42-7499 Tokyo

## OLYMPUS AMERICA INC.

Two Corporate Center Drive, Melville, NY 11747-3157, U.S.A. Tel. 631-844-5000

### Technical Support (USA)

24/7 online automated help: <http://support.olympusamerica.com/>

Phone customer support: Tel. 1-888-553-4448 (Toll-free)

Our phone customer support is available from 8 am to 10 pm  
(Monday to Friday) ET

E-Mail: [distec@olympus.com](mailto:distec@olympus.com)

Olympus software updates can be obtained at: <http://olympus.com/digital/>

## OLYMPUS OPTICAL CO. (EUROPA) GMBH.

Premises/Goods delivery: Wendenstrasse 14-18, 20097 Hamburg, Germany  
Tel. +49 (0) 40-23 77 30/+49 (0) 40-23 77 33

Letters: Postfach 10 49 08, 20034 Hamburg, Germany

### European Technical Customer Support:

Please visit our homepage <http://www.olympus-europa.com>

or call our TOLL FREE NUMBER : **00800 - 67 10 83 00**

for Austria, Belgium, Denmark, Finland, France, Germany, Italy, Luxembourg,  
Netherlands, Norway, Portugal, Spain, Sweden, Switzerland, United Kingdom

- Please note some (mobile) phone services/provider do not permit access or request an additional prefix to +800 numbers.

For all not listed European Countries and in case that you can't get connected to the above mentioned number please make use of the following

CHARGED NUMBERS: **+49 (0) 180 5-67 10 83** or **+49 (0) 40-23 77 38 99**

Our Technical Customer Support is available from 9 am to 6 pm MET (Monday to Friday)

**OLYMPUS**

# CAMEDIA

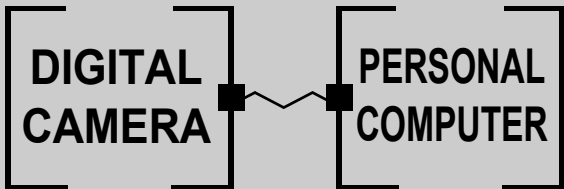

DIGITAL CAMERA — PC CONNECTION  
**OPERATION MANUAL**

How to use your PC to get the most from images taken with your digital camera.

- Thank you for purchasing an Olympus digital camera.
- This manual provides instructions on how to install the USB driver. To ensure correct installation, refer only to these installation procedures.

# Introduction

This manual explains in detail how to connect your Olympus digital camera to a computer. Read it carefully and keep it in a safe place for future reference.

## **About this manual**

- The information contained in this manual may be subject to change without notice. For the latest information on the product, please consult your local Olympus representative.
- The information contained in this manual has been compiled by taking all possible measures to ensure its accuracy. However, if you find any errors or incomplete information, please contact your local Olympus representative.
- It is prohibited by copyright laws to duplicate in part or in whole the information contained in this manual, except for personal use. Reproduction without permission of the copyright owner is prohibited.
- The PC screens shown in this manual may differ slightly from the actual displays on some PC models.

## **Trademarks**

- Microsoft and Windows are registered trademarks of Microsoft Corporation.
- Macintosh is a trademark of Apple Computer Inc.
- All other company and product names are registered trademarks and/or trademarks of their respective owners.

# INDEX

**Flowchart . . . . . 4**

**Identifying the OS . . . . . 6**

**Windows (98/Me/2000/XP) . . . . . 8**

**Macintosh (OS 9/X). . . . . 23**

**Downloading image files using other OS  
(For other OS users). . . . . 31**

Windows

Macintosh

# Flowchart

By connecting the camera to a computer with the provided USB cable, images on a card can be transferred to the computer. Some OS's (operating systems) may need a special setup before connecting to the camera for the first time. Follow the chart below.

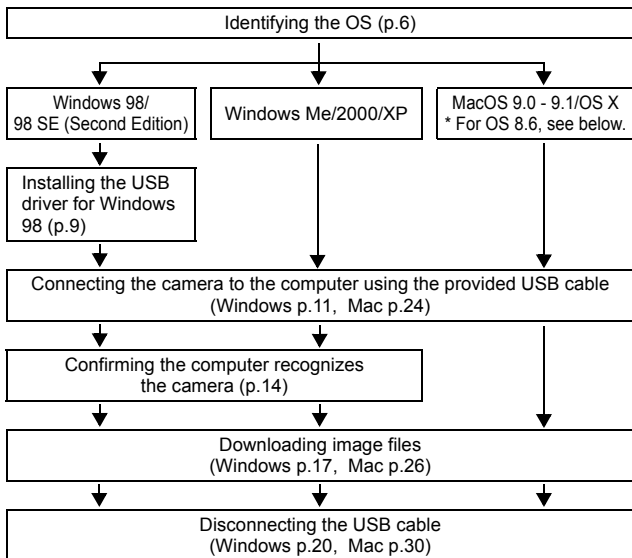

\* Even if your computer has a USB connector, data transfer may not function correctly if you are using one of the operating systems listed below or if you have an add-on USB connector (extension card, etc.).

- Windows 95/NT 4.0
- Windows 98/98 SE upgrade from Windows 95
- Mac OS 8.6 or lower (except Mac OS 8.6 equipped with USB MASS Storage Support 1.3.5 installed at the factory)
- Data transfer is not guaranteed on a home-built PC system or PCs with no factory installed OS.



- When connecting the camera to the computer, make sure that there is sufficient remaining battery power. When connected (transmitting) to the computer, the camera does not enter the sleep mode nor will the camera's power turn off automatically. Depending on the camera model, when the battery power runs out or the internal temperature rises, the camera may stop operating automatically. This could cause the computer to malfunction, and any image data (file) being transmitted may be lost. Be careful when downloading files for a long period of time. Use the AC adapter (optional) when downloading files.
- If you connect or disconnect the AC adapter when the camera is connected to the computer and is running on battery power, it may result in the loss of image data on the card or cause a malfunction in the computer. Before connecting or disconnecting the AC adapter, disconnect the camera from the computer and make sure that the camera is turned off.
- To avoid computer malfunctions, do not turn off the camera when the camera is connected to a computer.
- If the camera is connected to the computer via a USB hub, operation may not be stable if there are any compatibility problems between the computer and the hub. In such cases, do not use the hub and connect the camera directly to the computer.



- You can view images using: graphics applications that support the JPEG file format (Paint Shop Pro, Photoshop, etc.); Internet browsers (Netscape Communicator, Microsoft Internet Explorer, etc.); CAMEDIA Master software; or other software. For details on using commercial graphics applications, refer to their instruction manuals.
- QuickTime is needed for playing back movies. QuickTime is included on the provided software CD.
- If you want to process images, make sure to download them to your computer first. Depending on the software, image files may be destroyed if the images are processed (rotated, etc.) while they are on the card.

# Identifying the OS

Identify the OS on your computer before connecting the camera. How to identify the OS depends on the computer.

## ● Windows

### 1 Double-click the “My Computer” icon on your desktop.

When the “My computer” icon is not on your desktop, click “Control Panel” from the “Start” menu.

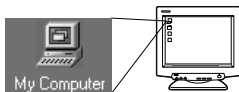

### 2 Double-click the “Control Panel” icon.



### 3 Double-click the “System” icon.



The way the file icons inside the folder appear may vary depending on your version of Windows. If you don't see the icon you are looking for, click on “view all Control Panel options” on the left of the window.



#### 4 A System Properties window will appear. Note and record the “System:” information.

Confirm that your system is Windows 98, 98 SE, Me, 2000 Professional or Windows XP, then press “OK” to close the window.

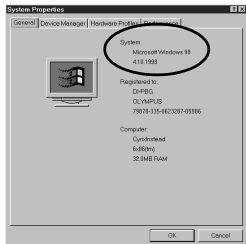

If your OS is Windows 98/98 SE, proceed to “Installing the USB driver for Windows 98” (👉 p.9).

Users running Windows Me/2000/XP 👉 p.11

Users running other OS 👉 p.31

## ● Mac OS (Macintosh)

Select “About This Computer” from the Apple menu on the menu bar.

A window appears with the name of the computer’s OS.

Confirm that the OS is OS 9.0-9.1 or OS X.

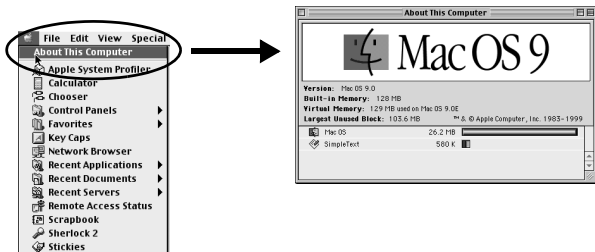

Users running Mac OS 9/X 👉 p.23

Users running other OS 👉 p.31

# Windows

## Using Windows 98/Me/2000/XP

### Make sure that:

- Your computer is turned on and Windows is running.
- If you are running any applications, quit them all.
- You are recommended to power the camera using the optional AC adapter. If the battery power runs out while the computer is accessing the card in the camera, the camera will turn off in the middle of the operation and this could destroy image files (data). If you are using batteries, make sure that there is sufficient remaining battery power.

<b>Installing the USB driver for Windows 98 (When using Windows 98/98 SE) .....</b>	<b>9</b>
<b>Connecting the camera to the computer .....</b>	<b>11</b>
<b>Confirming the computer recognizes the camera .....</b>	<b>14</b>
<b>Confirming the USB driver is installed .....</b>	<b>15</b>
<b>Downloading images to your computer.....</b>	<b>17</b>
<b>Disconnecting the camera from your computer .....</b>	<b>20</b>

# Installing the USB driver for Windows 98 (When using Windows 98/98 SE)

If your OS is Windows 98/98 SE, you must install the USB driver. Follow the instructions below to install the USB driver in your computer. Once it is fully installed, you do not need to repeat the procedure again.

**If your OS is Windows Me/2000/XP, you do not need to install the USB driver.** Proceed to “Connecting the camera to the computer” (👉 p.11).

- 1** Insert the provided software CD into your CD-ROM drive.

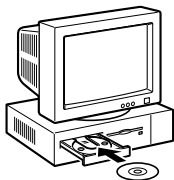

- 2** The Olympus Windows Installer should automatically launch. Click “USB Driver”.

If the USB driver is already installed in your computer, this option will not appear.

- This option will not appear if you are using Windows Me/2000/XP.

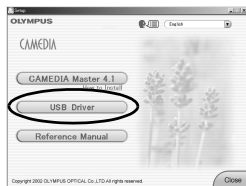

If the installer is not automatically launched, select “Run..” on the “Start” menu and then execute “(drive letter):/ Information.exe”.



The drive letter of the CD-ROM varies depending on the computer.  
To identify the drive letter, double-click “My Computer” on the desktop.

- 3** Click “Continue”. The installation of the USB driver will start.



- 4** Click “OK” to restart your computer and the installation is complete.

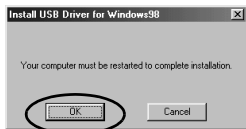

- 5** When the computer has restarted, installation is complete. If the Olympus Windows Installer screen appears, click “Close” and remove the CD-ROM from the CD-ROM drive.

# Connecting the camera to the computer

Users running Windows 98/98SE need to install the USB drive before connecting the camera to your computer for the first time. (☞ p.9)

- 1** Insert the marked end of the provided USB cable into the USB port on your computer as shown below.

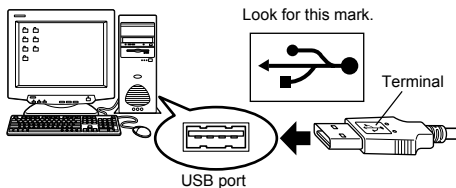

Note

The location of the USB port varies depending on the computer. For details, refer to your computer's manual.

- 2** After making sure that the camera is turned off, connect the end of the USB cable to the USB connector on the camera.

The location of the USB connector or multi connector varies depending on the camera model. Refer to the camera manual for details.

## Camera with a USB connector

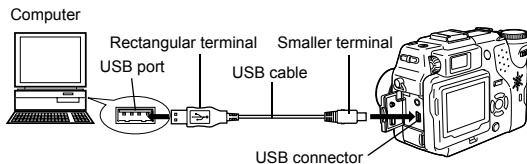

## Camera with a multi connector

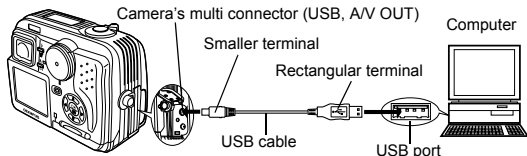

### 3 Turn the camera on.

- **Camera with a lens barrier**

The power turns on automatically, with the exception of some models which require you to press the  (monitor) button.

When the camera is turned on, the lamp on the right of the viewfinder lights up.

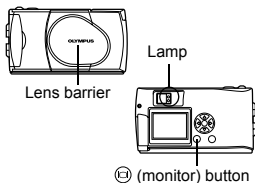

- **Camera with a  mode**

Set the mode dial to . (If the camera has a power switch as well as a mode dial, turn the power switch to ON.)

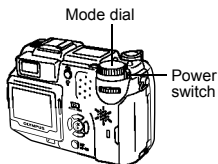
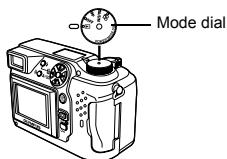

- **Camera with a  mode (Camera setup/connection mode)**

Set the mode dial to  to turn the camera on.

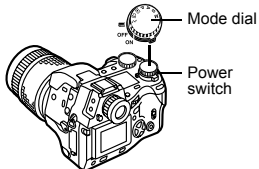

## 4 The computer recognizes the camera as a new device.

When you connect the camera to the computer for the first time, the computer automatically recognizes the camera. Click "OK" when the message saying that the installation is completed appears. The computer recognizes the camera as a "Removable Disk".

### ● Windows XP

You can download image files from the camera easily. Select "Copy pictures to folder on my computer using Microsoft Scanner and Camera Wizard", then follow the on-screen instructions. You may also select "take no action" to bypass the Microsoft Scanner and Camera Wizard. You may then use a more advanced image viewing/editing program such as Olympus CAMEDIA Master software. For detailed instructions on downloading, refer to the CAMEDIA Master software user's guide.



---

When the camera is connected to the computer, none of the camera buttons are functional.

# Confirming the computer recognizes the camera

## 1 Double-click the “My Computer” icon on the desktop.

For users running Windows XP, click “My Computer” from the “Start” menu.

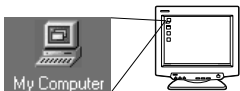

## 2 Make sure the “Removable Disk” icon appears in the window.

There may already be other “Removable Disk” icons for other devices, such as a removable media drive or USB SmartMedia Reader/Writer. In this case, the digital camera is recognized as another “Removable Disk”.

If you cannot find the icon, the camera and computer are not connected properly. Turn the camera off, disconnect the camera from the computer and connect again, or proceed to “Confirming the USB driver is installed” (☞ p.15) to make sure that the USB driver is fully installed.

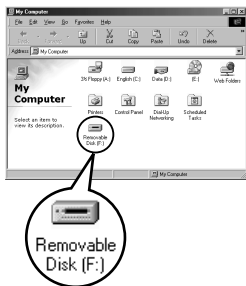



# Confirming the USB driver is installed

If the computer does not recognize the camera as a Removable Disk, follow the procedure below to check whether the USB driver has been fully installed.

- 1** Open "My Computer" and double-click the "Control Panel" icon.  
For users running Windows XP, open "Control Panel" from the "Start" menu.



- 2** Double-click the "System" icon.

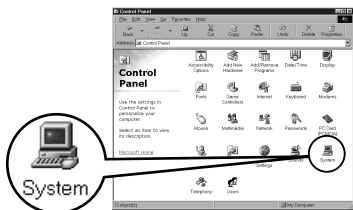

- 3** The System window will appear. Click the "Device Manager" tab.

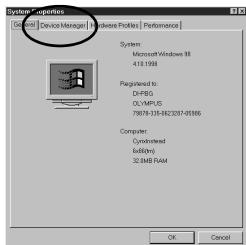

#### 4 Confirm that “OLYMPUS Digital Camera” is in the “Universal Serial Bus Controller” category.

If you cannot find the “OLYMPUS Digital Camera”, turn the camera off, disconnect the camera from the computer and start again.

Users running Windows 98/98 SE start again from “Confirming the USB driver is installed”, and Users running Window Me/2000/XP start from “Connecting the camera to the computer”.

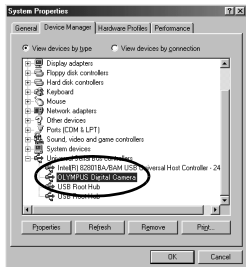

#### Note

If the USB driver was successfully installed, you can find the following in the “Device Manager”.

- the name of the camera you have connected listed under “Disk drives”
- “OLYMPUS Digital Camera” listed as one of the items in the “Universal Serial Bus Controller” category

# Downloading images to your computer

## 1 Double-click the “My Computer” icon on the desktop.

For users running Windows XP, click “Control Panel” from the “Start” menu.

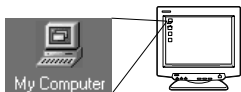

## 2 Double-click the “Removable Disk” icon.

A new “Removable Disk” icon appears when the camera is connected to the computer, as the digital camera is recognized as a “Removable Disk”.

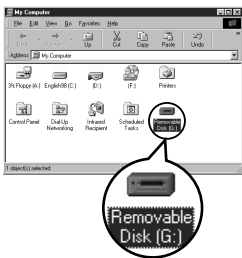

### Note

If an error message appears when you double-click the icon, there may be a problem with one of the following:

- ① the camera's power source (the AC adapter is not properly connected or the battery power is low)  
Make sure that the AC adapter is correctly connected or that the batteries are not running low.
- ② the card (there is no card in the camera or there is a problem with the card)  
Check that you can play back pictures stored on the card on the monitor of your digital camera.

## 3 Double-click the “Dcim” folder.

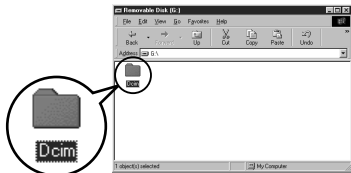

#### 4 Double-click the “100olymp” folder.

Image files (JPEG files) with file names such as “P1010001.jpg” are displayed.

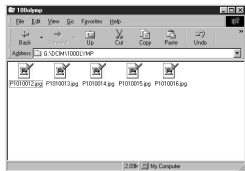

- The camera automatically assigns folder names and file names according to the following rules.

Folder name	File name
(Example) <b>100olymp</b>	(Example) <b>P1010001.jpg</b>
↓	↓ ↓ ↓
Serial number	Month / Day / Serial number

- Serial numbers of image files run from 0001 to 9999.
- Serial numbers of folders run from 100 to 999.
- When file number 9999 is reached, a new folder is created and assigned the next number.
- Months January through September are expressed by the numbers 1 through 9, October by the letter A, November by B and December by C.

#### 5 Double-click the “My Documents” icon on the desktop.

If you cannot find the icon on the desktop, select “Explorer” on the Start menu and double-click the “My Documents” icon.

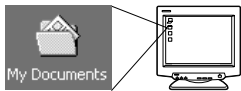

The “My Documents” window is displayed.



- 6** Drag & drop the image you want to save in the computer (in this case, P1010012.jpg) to the “My Documents” window.

The image is saved in the computer (in My Documents folder).

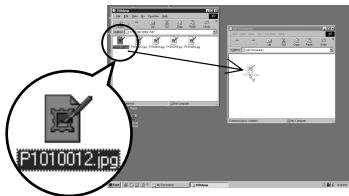

- To select all files, choose Edit > Select all.



Note

When the image file has been downloaded to the computer, you can view images by double-clicking the image files downloaded to your computer. The files will be opened in the default image viewer of the operating system. If you want to view the image a different size or process it, you will need to open the image with software that supports JPEG or TIFF images files, such as Paint Shop Pro, Photoshop or CAMEDIA Master software.



Caution

The lamp on the right of the viewfinder or the card access lamp blinks while the image is being copied. Never open the card cover on the camera, load or remove the batteries, or connect or disconnect the AC adapter while the lamp is blinking as the image files may be destroyed.

# Disconnecting the camera from your computer

If your OS is Windows Me/2000, proceed to “Windows Me/2000/XP” (p.21).

## ● Windows 98

- 1** Make sure that the lamp on the right of the viewfinder or the card access lamp is not blinking.

Some camera models have either a lamp on the right of the viewfinder or a card access lamp, and the location varies depending on the model. Refer to your camera's reference manual.

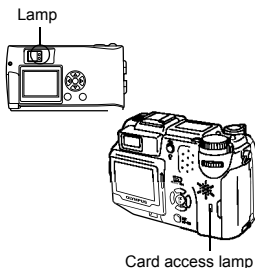

- 2** Double-click the “My Computer” icon and right-click the “Removable Disk” to display the menu.



- 3** Click “Eject” on the menu.



- 4** Make sure that the lamp on the right of the viewfinder or the card access lamp is not blinking.

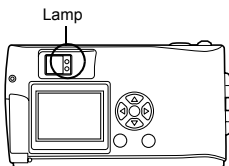

- 5** Remove the USB cable from the camera.

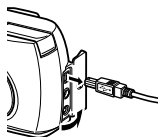

- 6** Remove the USB cable from your computer.

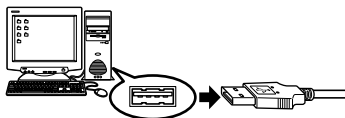

## ● Windows Me/2000/XP

- 1** Make sure that the lamp on the right of the viewfinder or the card access lamp is not blinking.

Some camera models have either a lamp on the right of the viewfinder or a card access lamp, and the location varies depending on the model. Refer to your camera's reference manual.

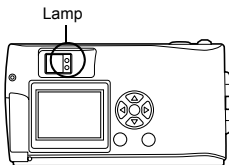

- 2** Click the  “Unplug or Eject Hardware” icon on the task bar.

The message saying that the drive has been stopped appears.

- 3** Click on the message.

The “Unplug or Eject Hardware” window appears.

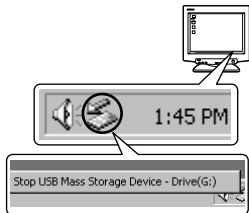

- 4** When a message appears, click “OK”.



- 5** Remove the USB cable from the camera.

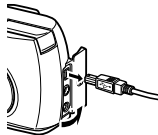

- 6** Remove the USB cable from your computer.

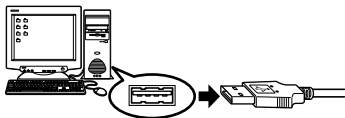

If the window returns the following message when you click “Unplug or Eject Hardware”, first make sure that no image data is being downloaded from the camera, and then remove the USB cable.





# Macintosh

## Using Mac OS (9/X)

### Make sure that:

- Your computer is turned on and Mac OS is running.
- If you are running any applications, quit them all.
- You are recommended to power the camera using the optional AC adapter. If the battery power runs out while the computer is accessing the card in the camera, the camera will turn off in the middle of the operation and this could destroy image files (data). If you are using batteries, make sure that there is sufficient remaining battery power.

If you are running Mac OS X, the connection to the computer and downloading the image data are verified. Restrictions such as the following may occur due to the OS.

- The image file properties are not displayed correctly.
- Images in the camera cannot be opened without first downloading them. etc.

For more details, visit the Olympus web site.

<b>Connecting the camera to the computer .....</b>	<b>24</b>
<b>Downloading images to your computer.....</b>	<b>26</b>
<b>Disconnecting the camera from your computer .....</b>	<b>30</b>

# Connecting the camera to the computer

- 1** Insert the marked end of the USB cable into the USB port on your computer as shown below.

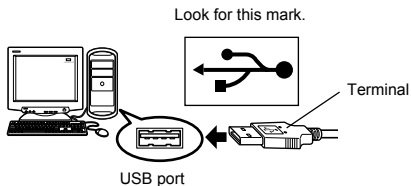

The location of the USB port varies depending on the computer. For details, refer to your computer's manual.

- 2** After making sure that the camera is turned off, connect the end of the USB cable to the USB connector on the camera.

The location of the USB connector or multi connector varies depending on the camera model. Refer to the camera manual for details.

## Camera with a USB connector

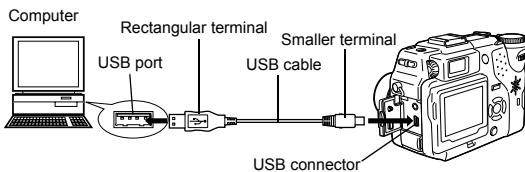

## Camera with a multi connector

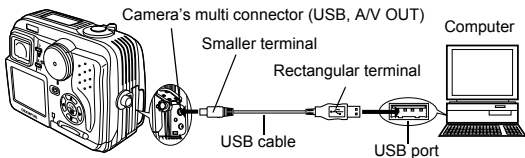

### 3 Turn the camera on.

#### ● Camera with a lens barrier

The power turns on automatically, with the exception of some models which require you to press the  (monitor) button.

When the camera is turned on, the green lamp on the right of the viewfinder lights up.

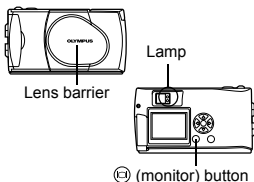

#### ● Camera with a mode

Set the mode dial to . (If the camera has a power switch as well as a mode dial, turn the power switch to ON.)

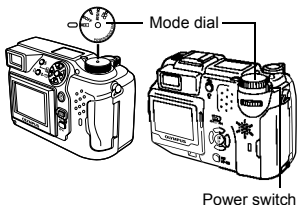

#### ● Camera with a mode (Camera setup/connection mode)

Set the mode dial to  to turn the camera on.

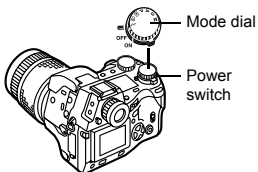

### 4 The computer recognizes the camera as a new device.

The computer recognizes the camera automatically and an "Untitled" icon appears on the desktop.

If you cannot find this icon, turn off the camera and connect again.



#### ● Mac OS X

When the computer has recognized the camera, the Apple Image Capture software automatically launches.  p.29



When the camera is connected to the computer, none of the camera buttons are functional.

# Downloading images to your computer

## ● Mac OS 9

You can download images from the camera and save them in your computer (in this case, in the Hard Disk).

- 1** Double-click the “Untitled” icon displayed on the desktop when the camera is connected to the computer.

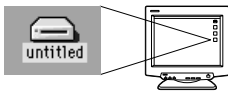

If you cannot find this icon, or if an error message appears when you double-click the icon, there may be a problem with one of the following:

- ① the camera's power source (the AC adapter is not properly connected or the battery power is low)
- ② the card (there is no card in the camera or there is a problem with the card)  
Check that you can play back pictures on the monitor of your camera.
- ③ the USB cable (the camera is not properly connected to the computer by the USB cable).
- ④ Apple “File Exchange” extension is not enabled.
  - Please refer to your Apple operating system manual for instructions on how to enable this extension.

- 2** Double-click the “Dcim” folder.

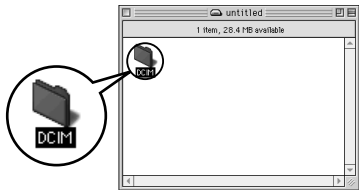

- 3** Double-click the “100OLYMP” folder.

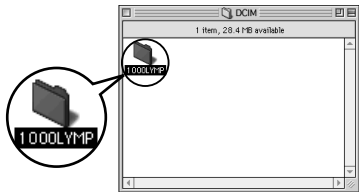
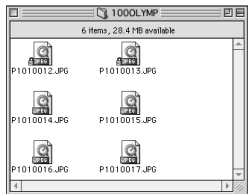
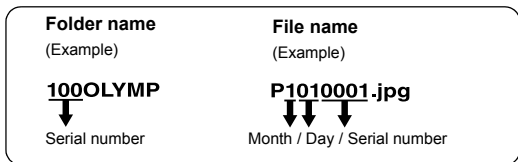

Image files (JPEG files) with file names such as “P1010001.JPG” are displayed.



- The camera automatically assigns folder names and file names according to the following rules.



- Serial numbers of image files run from 0001 to 9999.
- Serial numbers of folders run from 100 to 999.
- When file number 9999 is reached, a new folder is created and assigned the next number.
- Months January through September are expressed by the numbers 1 through 9, October by the letter A, November by B and December by C.

- 4 Double-click the “Macintosh HD” icon on the desktop.

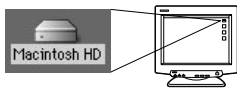

The “Hard Disk” window is displayed.

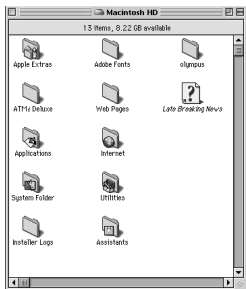

- 5** Drag & drop the image you want to save in the computer (in this case, P1010012.JPG) to the “Hard Disk” window.

The image is saved in the computer (in the Hard disk).

- To select all images, click Edit > Select all.

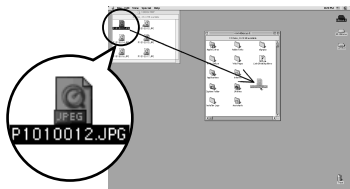

When the image file has been copied to the computer, you can view images by double-clicking the image files in the “Hard Disk” folder. The files will be opened in the default image viewer of the operating system. If you want to view the image a different size or process it, you will need to open the image with software that supports JPEG or TIFF images files, such as Paint Shop Pro, Photoshop or CAMEDIA Master software.



The lamp on the right of the viewfinder or the card access lamp blinks while the image is being copied. Never open the card cover on the camera, load or remove the batteries, or connect or disconnect the AC adapter while the lamp is blinking as the image files may be destroyed.

## ● Mac OS X

Malfunctions such as the following may occur due to the OS.

- If the camera is not connected correctly, a malfunction occurs in the computer.
- Date and time information of image files is not accurately displayed.
- If the card cover of the camera is opened while connecting to the computer, the “untitled” icon does not disappear from the desktop. etc.

When the computer has recognized the camera, the Apple Image Capture software dialog appears.

**1** From the “Download To” menu, select a destination folder.

**2** To download all images, click “Download All”.

To selectively download images, click “Download Some” and highlight the desired images.



The images are transferred from the camera to your computer.



If you are operating Mac OS X and you want to download images using the same procedure as for Mac OS 9, select “File > Close” and exit the Apple Image Capture software. At this time, the camera is indicated as “unlabeled”.



Caution

If you use the Apple Image Capture software, images downloaded to your computer and transferred back to a card may not play back on the camera or may have other problems.

# Disconnecting the camera from your computer

- 1** Make sure that the lamp on the right of the viewfinder or the card access lamp is not blinking.

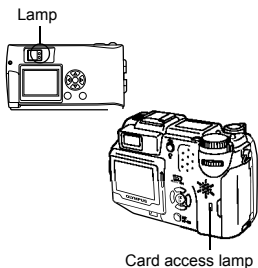

- 2** Drag the “untitled” icon on the desktop to “Trash”.

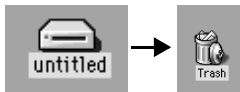

- 3** Make sure that the lamp on the right of the viewfinder or the card access lamp is not blinking.

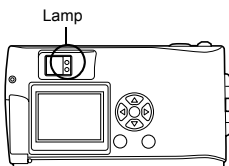

- 4** Remove the USB cable from the camera.

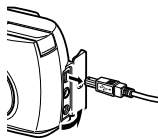

- 5** Remove the USB cable from your computer.

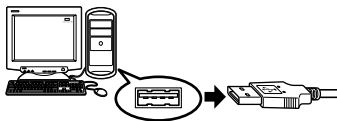



# Downloading image files using other OS (For other OS users)

Users running other OS cannot connect the camera directly to a computer.

● **Windows 95** ● **Windows NT** ● **Mac OS before OS 9**

You can download images directly to your computer using an optional floppy disk adapter or PC card adapter.

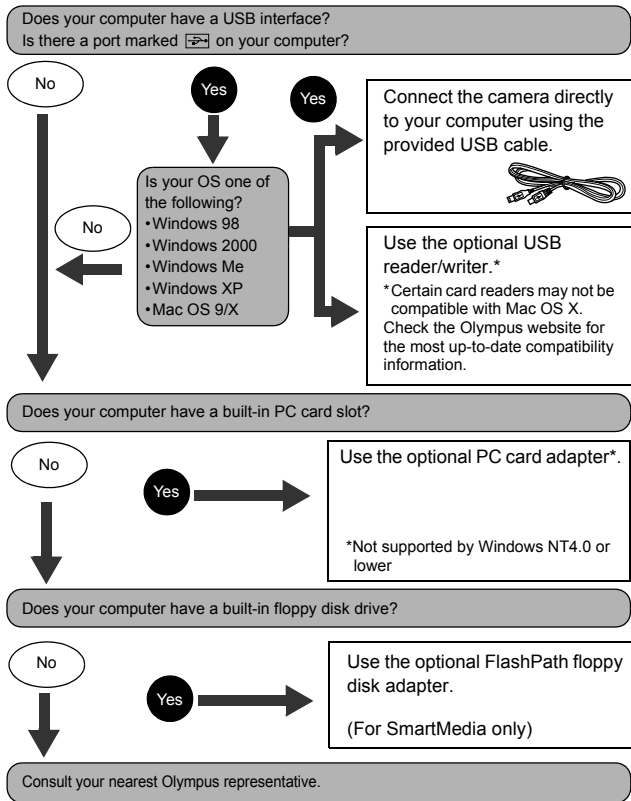

# OLYMPUS

<http://www.olympus.com/>

## OLYMPUS OPTICAL CO., LTD.

Customer support (Japanese language only): Tel. 0426-42-7499 Tokyo

## OLYMPUS AMERICA INC.

Two Corporate Center Drive, Melville, NY 11747-3157, U.S.A. Tel. 631-844-5000

### Technical Support (USA)

24/7 online automated help: <http://support.olympusamerica.com/>

Phone customer support: Tel. 1-888-553-4448 (Toll-free)

Our phone customer support is available from 8 am to 10 pm  
(Monday to Friday) ET

E-Mail: [distec@olympus.com](mailto:distec@olympus.com)

Olympus software updates can be obtained at: <http://olympus.com/digital/>

## OLYMPUS OPTICAL CO. (EUROPA) GMBH.

Premises/Goods delivery: Wendenstrasse 14-18, 20097 Hamburg, Germany  
Tel. +49 (0) 40-23 77 30/+49 (0) 40-23 77 33

Letters: Postfach 10 49 08, 20034 Hamburg, Germany

### European Technical Customer Support:

Please visit our homepage <http://www.olympus-europa.com>

or call our TOLL FREE NUMBER : **00800 - 67 10 83 00**

for Austria, Belgium, Denmark, Finland, France, Germany, Italy, Luxembourg,  
Netherlands, Norway, Portugal, Spain, Sweden, Switzerland, United Kingdom

- Please note some (mobile) phone services/provider do not permit access or request an additional prefix to +800 numbers.

For all not listed European Countries and in case that you can't get connected to the above mentioned number please make use of the following

CHARGED NUMBERS: **+49 (0) 180 5-67 10 83** or **+49 (0) 40-23 77 38 99**

Our Technical Customer Support is available from 9 am to 6 pm MET (Monday to Friday)