

MSP-EXP430G2 LaunchPad Experimenter Board

User's Guide



Literature Number: SLAU318C
July 2010–Revised August 2012

Preface	4
1 MSP-EXP430G2 LaunchPad Overview	5
1.1 Overview	5
1.2 Kit Contents	6
1.3 Revisions	7
2 Installation	7
2.1 Download the Required Software	7
2.2 Install the Software	7
2.3 Install the Hardware	7
3 Getting Started With MSP-EXP430G2 LaunchPad	8
3.1 Getting Started	8
3.2 Demo Application, Internal Temperature Measurement	8
4 Develop an Application With the MSP-EXP430G2 LaunchPad	9
4.1 Developing an Application	9
4.2 Program and Debug the Temperature Measurement Demo Application	9
4.3 Disconnect Emulator From Target With Jumper J3	10
4.4 Program Connected eZ430 Target Boards	11
4.5 Connecting a Crystal Oscillator	11
4.6 Connecting a Satellite Board	12
4.7 Supported Devices	12
4.8 MSP-EXP430G2 On-Board Emulator	13
5 MSP-EXP430G2 Hardware	14
5.1 Device Pinout	14
5.2 Schematics	15
5.3 PCB Layout	21
5.4 Bill of Materials (BOM)	24
6 Suggested Reading	25
7 Frequently Asked Questions (FAQ)	25

List of Figures

1	MSP-EXP430G2 LaunchPad Overview	6
2	Insert Device Into Target Socket	9
3	Code Composer Studio™ v4 in Debugging Mode	10
4	MSP-EXP430G2 LaunchPad With Attached eZ430-RF2500 Target Board	11
5	Device Pinout	14
6	Schematics, MSP-EXP430G2 Emulator (1 of 2), Revision 1.4	15
7	Schematics, MSP-EXP430G2 Emulator (2 of 2), Revision 1.4	16
8	Schematics, MSP-EXP430G2 Target Socket, Revision 1.4	17
9	Schematics, MSP-EXP430G2 Emulator (1 of 2), Revision 1.5	18
10	Schematics, MSP-EXP430G2 Emulator (2 of 2), Revision 1.5	19
11	Schematics, MSP-EXP430G2 Target Socket, Revision 1.5	20
12	Layout, LaunchPad Top Layer	21
13	Layout, LaunchPad Bottom Layer	22
14	Layout, LaunchPad Silkscreen	23

List of Tables

1	Jumper Connection J3 Between Emulator and Target	10
2	eZ430 Debugging Interface	11
3	Supported Devices	12
4	Features Supported by On-Board Emulator	13
5	Bill of Materials	24

Read This First

If You Need Assistance

If you have any feedback or questions, support for the MSP430™ devices and the MSP-EXP430G2 is provided by the Texas Instruments Product Information Center (PIC) and the TI E2E Forum (<https://community.ti.com/forums/12.aspx>). Contact information for the PIC can be found on the TI web site at <http://support.ti.com>. Additional device-specific information can be found on the MSP430 web site at <http://www.ti.com/msp430>.

Related Documentation from Texas Instruments

The primary sources of MSP430 information are the device-specific data sheets and user's guides available at the Texas Instruments MSP430 web site: <http://www.ti.com/msp430>.

MSP430 device user's guides, application reports, software examples and other MSP430 user's guides can be found at the Tech Docs section. The CCS user's guide includes detailed information on setting up a project and using Code Composer Studio for the MSP430 microcontroller ([SLAU157](#)).

Information specific to the MSP-EXP430G2 LaunchPad Experimenter Board, all the available IDEs, Software Libraries, and examples can be found at the Tools & Software section: <http://www.ti.com/tool/msp-exp430g2>.

FCC Warning

This equipment is intended for use in a laboratory test environment only. It generates, uses, and can radiate radio frequency energy and has not been tested for compliance with the limits of computing devices pursuant to subpart J of part 15 of FCC rules, which are designed to provide reasonable protection against radio frequency interference. Operation of this equipment in other environments may cause interference with radio communications, in which case, the user will be required to take whatever measures may be required to correct this interference his own expense.

MSP-EXP430G2 LaunchPad Experimenter Board

1 MSP-EXP430G2 LaunchPad Overview

1.1 Overview

The MSP-EXP430G2 low-cost experimenter board called LaunchPad is a complete development solution for the Texas Instruments MSP430G2xx Value Line series. The integrated USB-based emulator offers all the hardware and software necessary to develop applications for all MSP430G2xx series devices. The LaunchPad has an integrated DIP target socket that supports up to 20 pins, allowing MSP430™ Value Line devices to be dropped into the LaunchPad board. It also offers an on-board flash emulation tool allowing direct interface to a PC for easy programming, debugging, and evaluation. The LaunchPad experimenter board is capable of programming the eZ430-RF2500T target boards, the eZ430-Chronos watch module or the eZ430-F2012T/F2013T target boards. The USB interface provides a 9600-Baud UART serial connection from the MSP430G2xx device to the host PC or a connected target board.

The MSP-EXP430G2 can be used with IAR Embedded Workbench™ Integrated Development Environment (IDE) or Code Composer Studio™ (CCS) IDE to write, download, and debug applications. The debugger is unobtrusive, allowing the user to run an application at full speed with hardware breakpoints and single stepping available while consuming no extra hardware resources.

MSP-EXP430G2 LaunchPad features:

- USB debugging and programming interface featuring a driverless installation and application UART serial communication with up to 9600 Baud
- Supports all MSP430G2xx and MSP430F20xx devices in PDIP14 or PDIP20 packages
- Two general-purpose digital I/O pins connected to green and red LEDs for visual feedback
- Two push button for user feedback and device reset
- Easily accessible device pins for debugging purposes or as socket for adding customized extension boards
- High-quality 20-pin DIP socket for an easy plug-in or removal of the target device

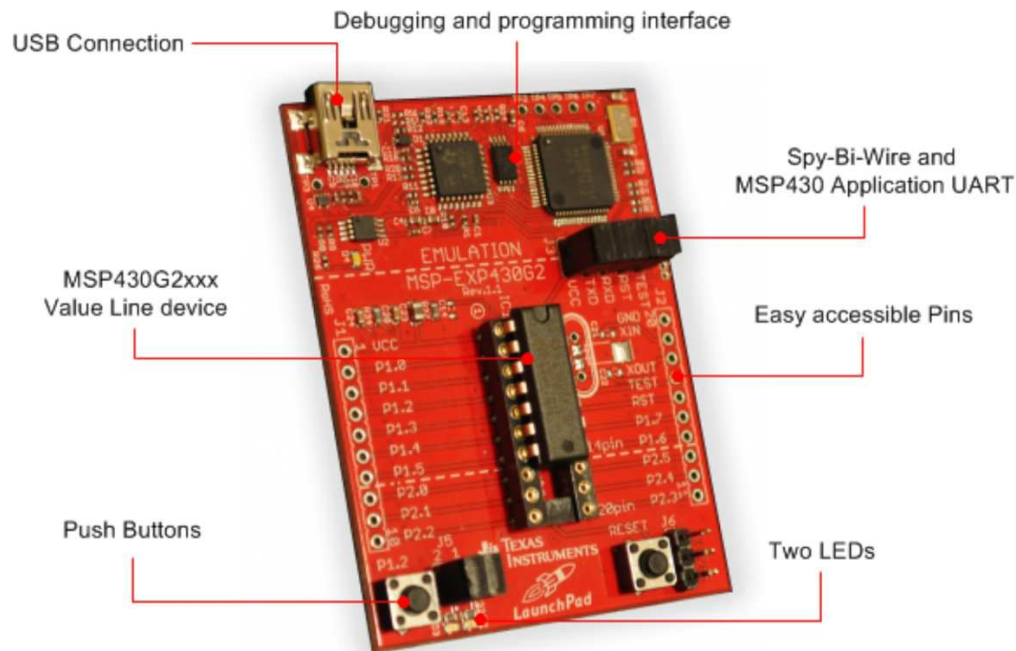

Figure 1. MSP-EXP430G2 LaunchPad Overview

For latest information on the MSP-EXP430G2 LaunchPad and all the necessary files, visit the MSP430 LaunchPad Wiki page [http://processors.wiki.ti.com/index.php/MSP430_LaunchPad_\(MSP-EXP430G2\)](http://processors.wiki.ti.com/index.php/MSP430_LaunchPad_(MSP-EXP430G2)). There you can find software examples, more details on the supported software, and where to order the MSP-EXP430G2 LaunchPad.

1.2 Kit Contents

The MSP-EXP430G2 experimenter kit includes the following hardware:

- LaunchPad emulator socket board (MSP-EXP430G2)
- Mini USB-B cable, 0.5 m
- Two MSP430 flash devices
 - MSP430G2553: Low-power 16-bit MSP430 microcontroller with an 8-channel 10-bit ADC, on-chip comparator, touch-sense enabled I/Os, universal serial communication interface, 16kB flash memory, and 512 bytes of RAM (preloaded with a sample program)
 - MSP430G2452: Low-power 16-bit MSP430 microcontroller with an 8-channel 10-bit ADC, on-chip comparator, touch-sense enabled I/Os, universal serial interface, 8kB flash memory, and 256 bytes of SRAM
- Two 10-pin PCB connectors female
- 32.768-kHz clock crystal from Micro Crystal (<http://www.microcrystal.com>)
- Quick start guide
- Two LaunchPad stickers

1.3 Revisions

The first production revision of the LaunchPad in 2010 was 1.3. In 2012 the LaunchPad board revision changed from 1.4 to 1.5 to align with the new release of Value Line devices. The differences in the schematic and the kit contents are:

- Layout and Schematic:
 - Voltage feedback in the emulator changed to increase startup stability (Rev 1.3 to Rev 1.4)
 - Rearranged jumper J3 to support a vertical jumpers position for the UART lines
 - VCC on the connector J4 can now be disconnected from the emulator VCC by J3
 - Pullup resistor R34 and capacitor C24 on P1.3 removed to reduce the current consumption
 - Presoldered male headers J1 and J2

2 Installation

The MSP-EXP430G2 LaunchPad installation consists of three easy steps:

1. Download the required software.
2. Install the selected IDE.
3. Connect the LaunchPad to the PC.

Then the LaunchPad is ready to develop applications or to use the pre-programmed demo application.

2.1 Download the Required Software

Different development software tools are available for the MSP-EXP430G2 LaunchPad development board. IAR Embedded Workbench™ KickStart IDE and Code Composer Studio™ (CCS) IDE are both available in a free limited version. IAR Embedded Workbench allows 4kB of C-code compilation. CCS is limited to a code size of 16kB. The software is available at <http://www.ti.com/msp430> or the LaunchPad Wiki page [http://processors.wiki.ti.com/index.php/MSP430_LaunchPad_\(MSP-EXP430G2\)](http://processors.wiki.ti.com/index.php/MSP430_LaunchPad_(MSP-EXP430G2)). There are many other compilers and integrated development environments (IDEs) available to use with the MSP-EXP430 LaunchPad including Rowley Crossworks and MSPGCC. However, example projects have been created using IAR Embedded Workbench KickStart and Code Composer Studio (CCS). For more information on the supported software and the latest code examples, visit the LaunchPad Wiki page.

2.2 Install the Software

Download one of the integrated development environments (IDEs). IAR KickStart and CCS offer the required driver support to work with the MSP-EXP430 LaunchPad onboard emulation. Once installed, the IDE should find the MSP-EXP430G2 LaunchPad as USB:HID debugging interface. Now all is set for developing MSP430G2xx based application on the LaunchPad.

2.3 Install the Hardware

Connect the MSP-EXP430G2 LaunchPad socket board with the enclosed USB cable to a PC. The driver installation starts automatically. If prompted for software, allow Windows to install the software automatically. This is possible only if either IAR KickStart or Code Composer Studio is already installed (see [Section 2.2](#)).

3 Getting Started With MSP-EXP430G2 LaunchPad

3.1 Getting Started

The first time the MSP-EXP430G2 LaunchPad Experimenter Board is used, a demo application automatically starts as soon as the board is powered from the USB host. To start the demo, connect the MSP-EXP430G2 LaunchPad with the included mini USB cable to a free USB port. The demo application starts with an LED toggle to show the device is active. More information about the demo application can be found in [Section 3.2](#).

3.2 Demo Application, Internal Temperature Measurement

The LaunchPad includes a pre-programmed MSP430G2553 device already installed in the target socket. When LaunchPad is connected via USB, the demo starts with an LED toggle sequence. The onboard emulation generates the supply voltage and all the signals necessary to start.

Press button P1.3 to switch the application to a temperature measurement mode. A reference temperature is taken at the beginning of this mode, and the LEDs of the LaunchPad signal a rise or fall in temperature by varying the brightness of the on-board red or green LED, respectively. The reference temperature can also be recalibrated with another button press on P1.3. The collected temperature data is also communicated via back-channel UART through the USB emulation circuitry back to the PC. The transmitted values representing the temperature measured with the MSP430G2553 internal temperature sensor in Fahrenheit and can be displayed with any terminal application or the Temperature Sensor GUI available on the MSP430 LaunchPad wiki page [http://processors.wiki.ti.com/index.php/MSP430_LaunchPad_\(MSP-EXP430G2\)](http://processors.wiki.ti.com/index.php/MSP430_LaunchPad_(MSP-EXP430G2)). The serial communication port on the PC must be configured with 2400 bps, one stop bit, and no flow control to display the values correctly.

The demo application uses the on-chip peripherals of the MSP430G2553 device such as the 10-bit ADC, which samples the internal temperature sensor, and 16-bit timers, which drive the PWM to vary brightness of the LEDs and enable software UART for communication with the PC. The MSP430G2553 offers a USCI interface that is capable of communicating through UART at up to 2 MBaud, but to be aligned with all the other MSP430G2xx devices, the demo uses the Timer UART implementation, which can be used on all the other devices. This way the demo can be used with any other MSP430G2xx device with an integrated ADC, without any change in the program. The source code for this pre-loaded demo application is available for download in the Projects section of the MSP430 LaunchPad wiki page. Further information on the Temperature Sensor application and other examples and applications can be found on the MSP430 LaunchPad wiki page as well.

The provided applications can be a great starting point for various custom applications and give a good overview of the manifold possibilities of the MSP430G2xx Value Line devices. Also available are the executable and source files for a GUI, which displays the data that is being communicated back to the PC from the LaunchPad.

4 Develop an Application With the MSP-EXP430G2 LaunchPad

4.1 Developing an Application

The integrated development environments (IDEs) shown in [Section 2](#) offer support for the whole MSP430G2xx Value Line. The MSP-EXP430G2 LaunchPad needs only a connection to the USB of the Host PC—there is no external hardware required. The power supply and the Spy-Bi-Wire JTAG signals TEST and RST must be connected with jumper J3 to allow the onboard emulation connection to the device, as shown in [Section 5](#). Now the preferred device can be plugged into the DIP target socket of the LaunchPad (see [Figure 2](#)). Both PDIP14 and PDIP20 devices of the MSP430G2xx Value Line and the MSP430F20xx family can be inserted into the DIP socket aligned to pin 1. A complete list of supported devices can be found in [Section 4.7](#).

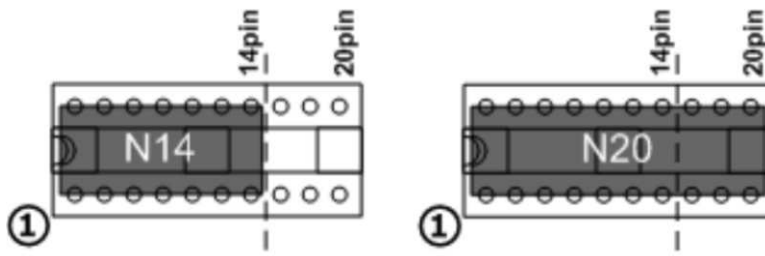

Figure 2. Insert Device Into Target Socket

The following example for Code Composer Studio v4 shows how to download and debug the demo application described in [Section 3.2](#).

4.2 Program and Debug the Temperature Measurement Demo Application

The source code of the demo application can be downloaded from the MSP430 LaunchPad wiki page. Download the project folder and unpack it to a location of your choice. For this demo, Code Composer Studio v4 or newer must be installed.

The demo application can be loaded to the CCS workspace by clicking File→Import. Select the location of the extracted project files and import Existing projects into Workspace. Now the MSP-EXP430G2-Launchpad project appears inside the CCS workspace. The project must be marked as the active project to start programming and debugging the device.

Connect the LaunchPad with an inserted MSP430G2553 device to the host PC and click the Debug button on the CCS Toolbar. The MSP-EXP430G2 LaunchPad is initialized and the download of the compiled demo application starts. The CCS view switches to a debugging interface once the download is completed and the application is ready to start. [Figure 3](#) shows Code Composer Studio v4 with the MSP-EXP430G2 LaunchPad demo application in debug view.

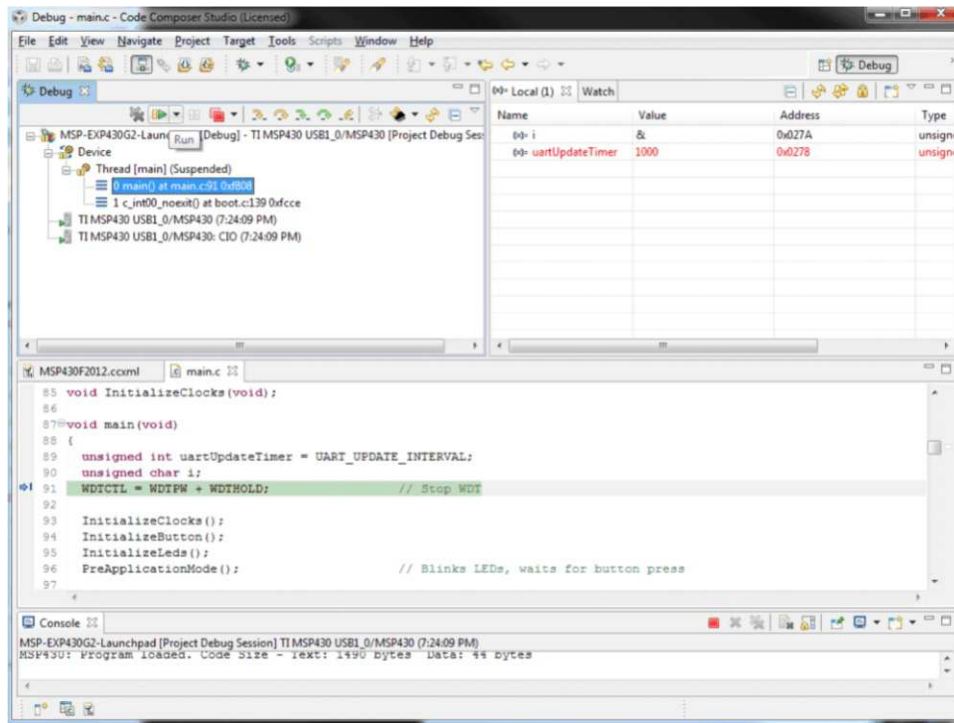

Figure 3. Code Composer Studio™ v4 in Debugging Mode

4.3 Disconnect Emulator From Target With Jumper J3

The connection between the MSP-EXP430G2 emulator and the attached target device can be opened with the jumper array J3. This can be useful to access an attached eZ430 target board by disconnecting the Spi-Bi-Wire JTAG lines RST and TEST or if the JTAG lines are used for other application purposes. The jumper array can also be used to measure the power consumption of the LaunchPad application. For this intention, all connections except VCC must be opened, and a multi meter can be used on the VCC Jumper to measure the current of the MSP-EXP430G2 target device and its peripherals. The jumper J5 VCC also must be opened if the LaunchPad board is powered with an external power supply over J6 Table 1 or the eZ430 interface J4.

NOTE: The assignment of jumper J3 has been changed in MSP-EXP430G2 revision 1.5, see the comments in Table 1 to find the assignment for a specific board revision.

Table 1. Jumper Connection J3 Between Emulator and Target

Jumper	Signal	Description
1	VCC	Target socket power supply voltage (power consumption test jumper) (located on 5 before Rev. 1.5)
2	TEST	Test mode for JTAG pins or Spy-Bi-Wire test clock input during programming and test (located on 1 before Rev. 1.5)
3	RST	Reset or Spy-Bi-Wire test data input/output during programming and test (located on 2 before Rev. 1.5)
4	RXD	UART receive data input (direction can be selected by jumper orientation) (located on 3 before Rev. 1.5)
5	TXD	UART transmit data output (direction can be selected by jumper orientation) (located on 4 before Rev. 1.5)

Jumpers 4 and 5 connect the UART interface of the emulator to the target device pins P1.1 and P1.2. The direction of the UART signal lines can be selected by the orientation of the attached jumpers. In horizontal orientation, the jumpers connect TXD to P1.1 and RXD to P1.2, as they are used for the software UART communication on the demo application (see Section 3.2). In vertical orientation, the jumpers connect the TXD signal to P1.2 and the RXD signal to P1.1, as required for the MSP430G2553 USCI.

4.4 Program Connected eZ430 Target Boards

The MSP-EXP430G2 LaunchPad can program the eZ430-RF2500T target boards, the eZ430-Chronos watch module, or the eZ430-F2012T/F2013T. To connect one of the eZ430 targets, connector J4 must be populated with a 0.050-in (1.27-mm) pitch male header, as shown in [Figure 4](#).

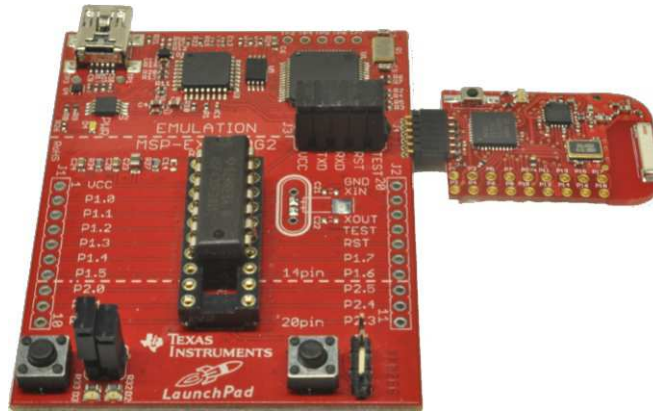

Figure 4. MSP-EXP430G2 LaunchPad With Attached eZ430-RF2500 Target Board

To program the attached target without interfering with the LaunchPad socket board, jumper connections TEST and RST of J3 must be open. The interface to the eZ430 target board is always connected to the MSP-EXP430G2 emulator, so the programming and debugging of a connected LaunchPad target device is possible only if the eZ430 target is not connected on the same time. The application UART, on the other hand, is connected directly to the LaunchPad target device, and jumper J3 can be closed to monitor the transmission from the LaunchPad target to the attached eZ430. This way both possible connections, from the device to the PC and from the device to the eZ430, can be established without changing the direction of the UART pins.

The VCC connection to the eZ430 interface is directly connected to the LaunchPad target VCC and can be separated with jumper J3, if the LaunchPad itself should be powered via a connected battery on J4. To supply the eZ430 interface with the onboard emulator the jumper J3 VCC needs to be closed.

[Table 2](#) shows the pinout of the eZ430 debugging interface J4, the first pin is the left pin located on the emulator part of the LaunchPad.

Table 2. eZ430 Debugging Interface

Pin	Signal	Description
1	TXD	UART transmit data output (UART communication from PC or MSP430G2xx to eZ430 target board)
2	VCC	Power supply voltage (J3 VCC needs to be closed to supply via onboard emulator)
3	TEST / SBWTCK	Test mode for JTAG pins and Spy-Bi-Wire test clock input during programming and test
4	RST / SBWTDIO	Reset, Spy-Bi-Wire test data input/output during programming and test
5	GND	Power supply ground
6	RXD	UART receive data input (UART communication from eZ430 target board to PC or MSP430G2xx)

4.5 Connecting a Crystal Oscillator

The MSP-EXP430G2 LaunchPad offers a footprint for a variety of crystal oscillators. The XIN and XOUT signals of the LFXT1 oscillator can support low-frequency oscillators like a watch crystals of 32768 Hz or a standard crystal with a range defined in the associated data sheet. The signal lines XIN and XOUT can also be used as multipurpose I/Os or as a digital frequency input. More information on the possibilities of the low-frequency oscillator and the possible crystal selection can be found in the *MSP430x2xx Family User's Guide* ([SLAU144](#)) or the device-specific data sheet.

The oscillator signals are connected to J2 to use the signals on an attached application board. In case of signal distortion of the oscillator signals that leads to a fault indication at the basic clock module, resistors R29 and R28 can be used to disconnect the pin header J2 from the oscillating lines.

4.6 Connecting a Satellite Board

The LaunchPad is the perfect experimenter board to start hardware development with the MSP430G2xx Value Line. Connectors J1 and J2 and the power supply at J6 are aligned in a 0.1-in (2.54-mm) grid to allow an easy and inexpensive development of a breadboard extension module. These satellite boards can access all the signals of the LaunchPad target device. So the satellites can hold their own device and use the LaunchPad as a pure programming interface, or they can work with the device that is plugged into the LaunchPad socket. The alignment of the connectors and the pinout can be found in [Section 5](#). The MSP-EXP430G2 LaunchPad kit includes two female 10-pin PCB connectors to get started with the first extension board right away.

4.7 Supported Devices

Texas Instruments offers several MSP430 devices in a PDIP package that is compatible with LaunchPad. [Table 3](#) shows the supported devices.

Table 3. Supported Devices

Part Number	Family	Description
MSP430F2001	F2xx	16-bit Ultra-Low-Power Microcontroller, 1kB Flash, 128B RAM, Comparator
MSP430F2002	F2xx	16-bit Ultra-Low-Power Microcontroller, 1kB Flash, 128B RAM, 10-Bit SAR A/D, USI for SPI/I2C
MSP430F2003	F2xx	16-bit Ultra-Low-Power Microcontroller, 1kB Flash, 128B RAM, 16-Bit Sigma-Delta A/D, USI for SPI/I2C
MSP430F2011	F2xx	16-bit Ultra-Low-Power Microcontroller, 2kB Flash, 128B RAM, Comparator
MSP430F2012	F2xx	16-bit Ultra-Low-Power Microcontroller, 2kB Flash, 128B RAM, 10-Bit SAR A/D, USI for SPI/I2C
MSP430F2013	F2xx	16-bit Ultra-Low-Power Microcontroller, 2kB Flash, 128B RAM, 16-Bit Sigma-Delta A/D, USI for SPI/I2C
MSP430G2001	G2xx	16-bit Ultra-Low-Power Microcontroller, 512B Flash, 128B RAM
MSP430G2101	G2xx	16-bit Ultra-Low-Power Microcontroller, 1kB Flash, 128B RAM
MSP430G2111	G2xx	16-bit Ultra-Low-Power Microcontroller, 1kB Flash, 128B RAM, Comparator
MSP430G2121	G2xx	16-bit Ultra-Low-Power Microcontroller, 1kB Flash, 128B RAM, USI for SPI/I2C
MSP430G2131	G2xx	16-bit Ultra-Low-Power Microcontroller, 1kB Flash, 128B RAM, 10-Bit SAR A/D, USI for SPI/I2C
MSP430G2201	G2xx	16-bit Ultra-Low-Power Microcontroller, 2kB Flash, 128B RAM
MSP430G2211	G2xx	16-bit Ultra-Low-Power Microcontroller, 2kB Flash, 128B RAM, Comparator
MSP430G2221	G2xx	16-bit Ultra-Low-Power Microcontroller, 2kB Flash, 128B RAM, USI for SPI/I2C
MSP430G2231	G2xx	16-bit Ultra-Low-Power Microcontroller, 2kB Flash, 128B RAM, 10-Bit SAR A/D, USI for SPI/I2C
MSP430G2102	G2xx	16-bit Ultra-Low-Power Microcontroller, 1kB Flash, 256B RAM, USI for SPI/I2C, 16 Touch-Sense Enabled I/O Pins
MSP430G2202	G2xx	16-bit Ultra-Low-Power Microcontroller, 2kB Flash, 256B RAM, USI for SPI/I2C, 16 Touch-Sense Enabled I/O Pins
MSP430G2302	G2xx	16-bit Ultra-Low-Power Microcontroller, 4kB Flash, 256B RAM, USI for SPI/I2C, 16 Touch-Sense Enabled I/O Pins
MSP430G2402	G2xx	16-bit Ultra-Low-Power Microcontroller, 8kB Flash, 256B RAM, USI for SPI/I2C, 16 Touch-Sense Enabled I/O Pins
MSP430G2112	G2xx	16-bit Ultra-Low-Power Microcontroller, 1kB Flash, 256B RAM, Comparator, USI for SPI/I2C, 16 Touch-Sense Enabled I/O Pins
MSP430G2212	G2xx	16-bit Ultra-Low-Power Microcontroller, 2kB Flash, 256B RAM, Comparator, USI for SPI/I2C, 16 Touch-Sense Enabled I/O Pins
MSP430G2312	G2xx	16-bit Ultra-Low-Power Microcontroller, 4kB Flash, 256B RAM, Comparator, USI for SPI/I2C, 16 Touch-Sense Enabled I/O Pins
MSP430G2412	G2xx	16-bit Ultra-Low-Power Microcontroller, 8kB Flash, 256B RAM, Comparator, USI for SPI/I2C, 16 Touch-Sense Enabled I/O Pins
MSP430G2132	G2xx	16-bit Ultra-Low-Power Microcontroller, 1kB Flash, 256B RAM, 10-Bit SAR A/D, USI for SPI/I2C, 16 Touch-Sense Enabled I/O Pins
MSP430G2232	G2xx	16-bit Ultra-Low-Power Microcontroller, 2kB Flash, 256B RAM, 10-Bit SAR A/D, USI for SPI/I2C, 16 Touch-Sense Enabled I/O Pins
MSP430G2332	G2xx	16-bit Ultra-Low-Power Microcontroller, 4kB Flash, 256B RAM, 10-Bit SAR A/D, USI for SPI/I2C, 16 Touch-Sense Enabled I/O Pins
MSP430G2432	G2xx	16-bit Ultra-Low-Power Microcontroller, 8kB Flash, 256B RAM, 10-Bit SAR A/D, USI for SPI/I2C, 16 Touch-Sense Enabled I/O Pins

Table 3. Supported Devices (continued)

Part Number	Family	Description
MSP430G2152	G2xx	16-bit Ultra-Low-Power Microcontroller, 1kB Flash, 256B RAM, 10-Bit SAR A/D, Comparator, USI for SPI/I2C, 16 Touch-Sense Enabled I/O Pins
MSP430G2252	G2xx	16-bit Ultra-Low-Power Microcontroller, 2kB Flash, 256B RAM, 10-Bit SAR A/D, Comparator, USI for SPI/I2C, 16 Touch-Sense Enabled I/O Pins
MSP430G2352	G2xx	16-bit Ultra-Low-Power Microcontroller, 4kB Flash, 256B RAM, 10-Bit SAR A/D, Comparator, USI for SPI/I2C, 16 Touch-Sense Enabled I/O Pins
MSP430G2452	G2xx	16-bit Ultra-Low-Power Microcontroller, 8kB Flash, 256B RAM, 10-Bit SAR A/D, Comparator, USI for SPI/I2C, 16 Touch-Sense Enabled I/O Pins
MSP430G2153	G2xx	16-bit Ultra-Low-Power Microcontroller, 1kB Flash, 256B RAM, 10-Bit SAR A/D, Comparator, USCI for I2C/SPI/UART, 24 Touch-Sense Enabled I/O Pins
MSP430G2203	G2xx	16-bit Ultra-Low-Power Microcontroller, 2kB Flash, 256B RAM, Comparator, USCI for I2C/SPI/UART, 24 Touch-Sense Enabled I/O Pins
MSP430G2313	G2xx	16-bit Ultra-Low-Power Microcontroller, 2kB Flash, 256B RAM, Comparator, USCI for I2C/SPI/UART, 24 Touch-Sense Enabled I/O Pins
MSP430G2333	G2xx	16-bit Ultra-Low-Power Microcontroller, 2kB Flash, 256B RAM, 10-Bit SAR A/D, Comparator, USCI for I2C/SPI/UART, 24 Touch-Sense Enabled I/O Pins
MSP430G2353	G2xx	16-bit Ultra-Low-Power Microcontroller, 2kB Flash, 256B RAM, 10-Bit SAR A/D, Comparator, USCI for I2C/SPI/UART, 24 Touch-Sense Enabled I/O Pins
MSP430G2403	G2xx	16-bit Ultra-Low-Power Microcontroller, 8kB Flash, 512B RAM,, Comparator, USCI for I2C/SPI/UART, 24 Touch-Sense Enabled I/O Pins
MSP430G2413	G2xx	16-bit Ultra-Low-Power Microcontroller, 8kB Flash, 512B RAM, Comparator, USCI for I2C/SPI/UART, 24 Touch-Sense Enabled I/O Pins
MSP430G2433	G2xx	16-bit Ultra-Low-Power Microcontroller, 8kB Flash, 512B RAM, 10-Bit SAR A/D, Comparator, USCI for I2C/SPI/UART, 24 Touch-Sense Enabled I/O Pins
MSP430G2453	G2xx	16-bit Ultra-Low-Power Microcontroller, 8kB Flash, 512B RAM, 10-Bit SAR A/D, Comparator, USCI for I2C/SPI/UART, 24 Touch-Sense Enabled I/O Pins
MSP430G2513	G2xx	16-bit Ultra-Low-Power Microcontroller, 16kB Flash, 512B RAM, Comparator, USCI for I2C/SPI/UART, 24 Touch-Sense Enabled I/O Pins
MSP430G2533	G2xx	16-bit Ultra-Low-Power Microcontroller, 16kB Flash, 512B RAM, 10-Bit SAR A/D, Comparator, USCI for I2C/SPI/UART, 24 Touch-Sense Enabled I/O Pins
MSP430G2553	G2xx	16-bit Ultra-Low-Power Microcontroller, 16kB Flash, 512B RAM, 10-Bit SAR A/D, Comparator, USCI for I2C/SPI/UART, 24 Touch-Sense Enabled I/O Pins

4.8 MSP-EXP430G2 On-Board Emulator

The MSP-EXP430G2 on-board emulator enables programming and debugging of supported MSP430 devices (see [Section 4.7](#)). It offers several features that are enabled by a 2-wire JTAG interface called Spy-Bi-Wire. For a more feature-complete emulator, the [MSP-FET430UIF](#) flash emulation tool may be more appropriate. See [Table 4](#) for more details on the MSP-EXP430G2 LaunchPad on-board emulator.

Table 4. Features Supported by On-Board Emulator

Feature	Support by LaunchPad (MSP-EXP430G2)
Supports MSP430F20xx, F21x2, F22xx, G2x01, G2x11, G2x21, G2x31, G2x53	✓
Allows fuse blow	
Adjustable target supply voltage	
Fixed 2.8-V target supply voltage	
Fixed 3.6-V target supply voltage	✓
4-wire JTAG	
2-wire JTAG	✓
Application UART	✓
Supported by CCS	✓
Supported by IAR	✓

5 MSP-EXP430G2 Hardware

5.1 Device Pinout

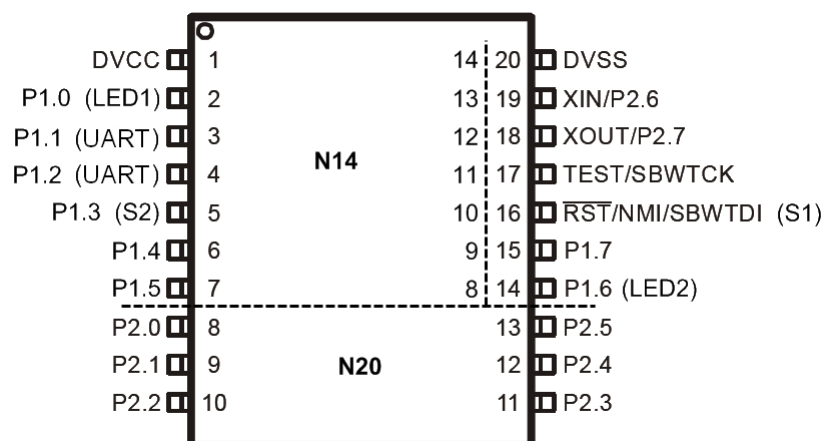

Figure 5. Device Pinout

5.2 Schematics

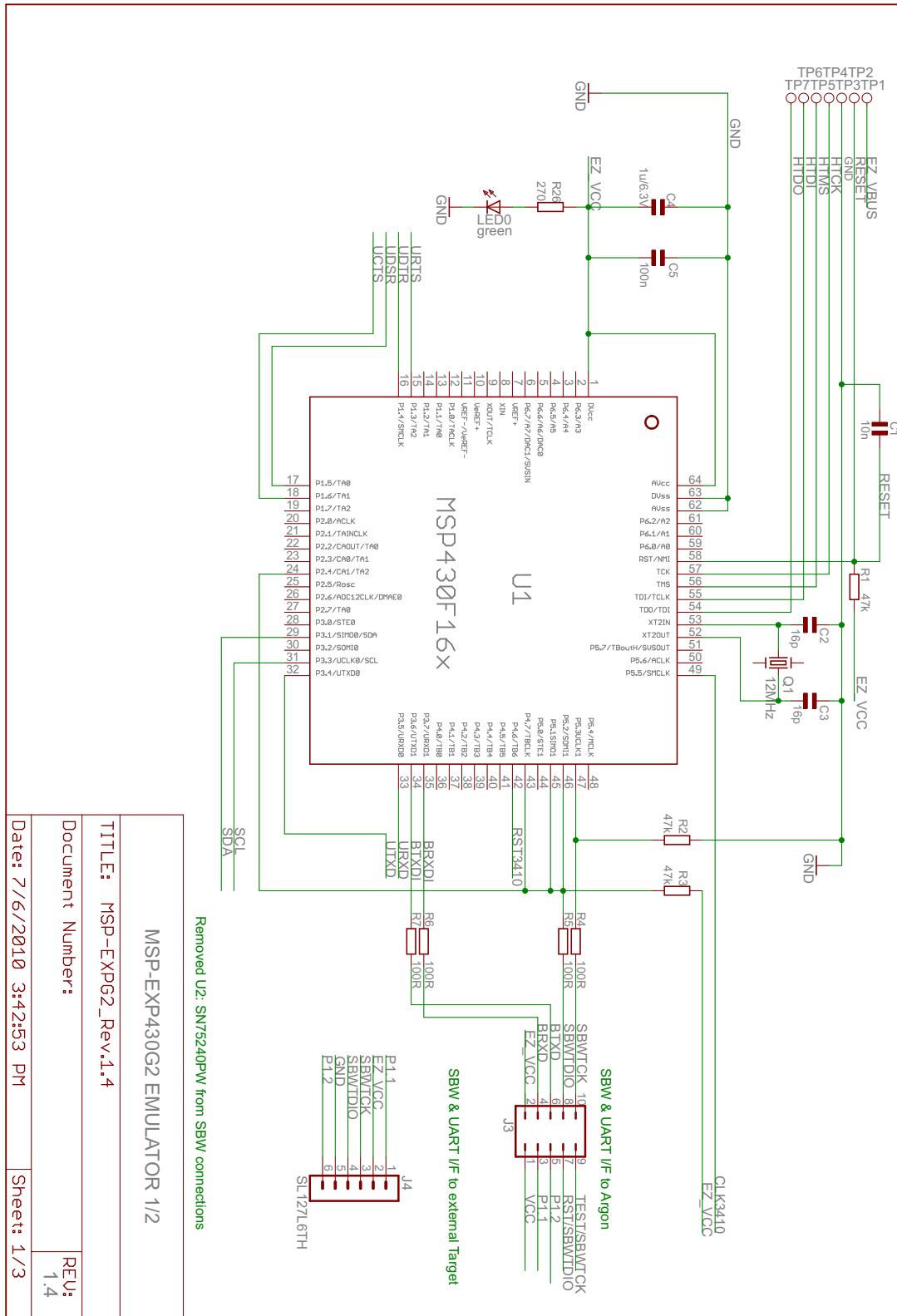

Figure 6. Schematics, MSP-EXP430G2 Emulator (1 of 2), Revision 1.4

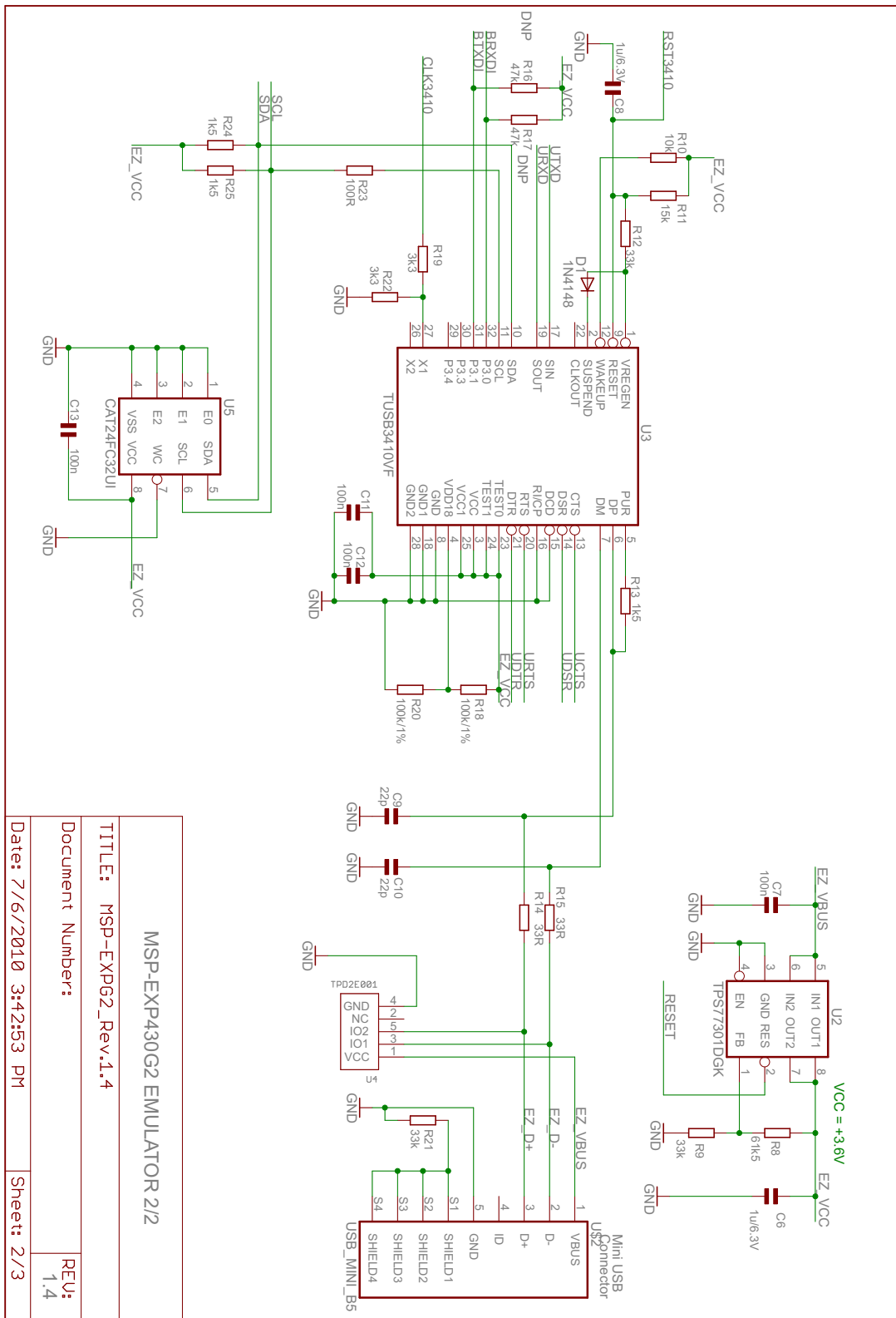

Figure 7. Schematics, MSP-EXP430G2 Emulator (2 of 2), Revision 1.4

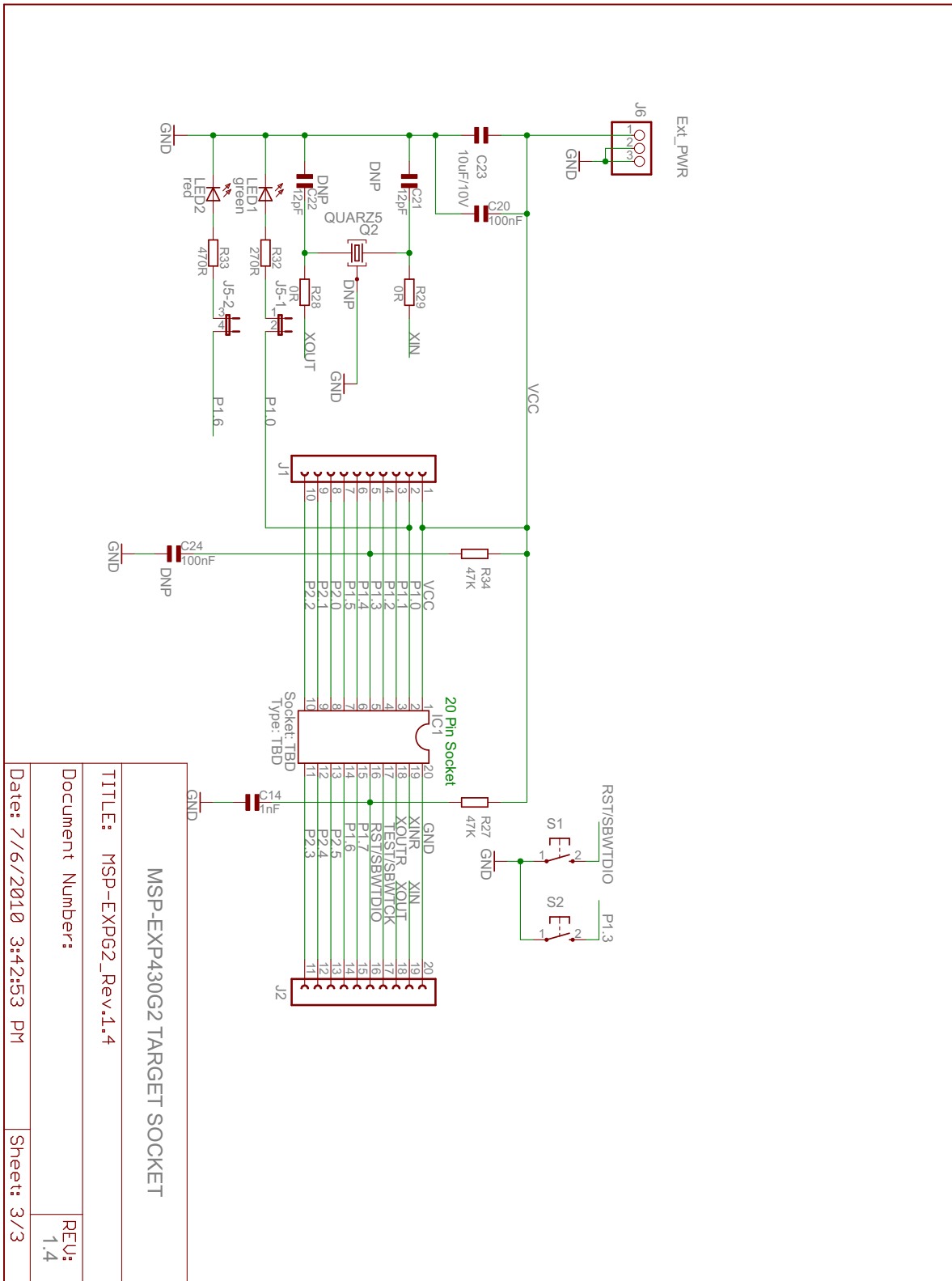

Figure 8. Schematics, MSP-EXP430G2 Target Socket, Revision 1.4

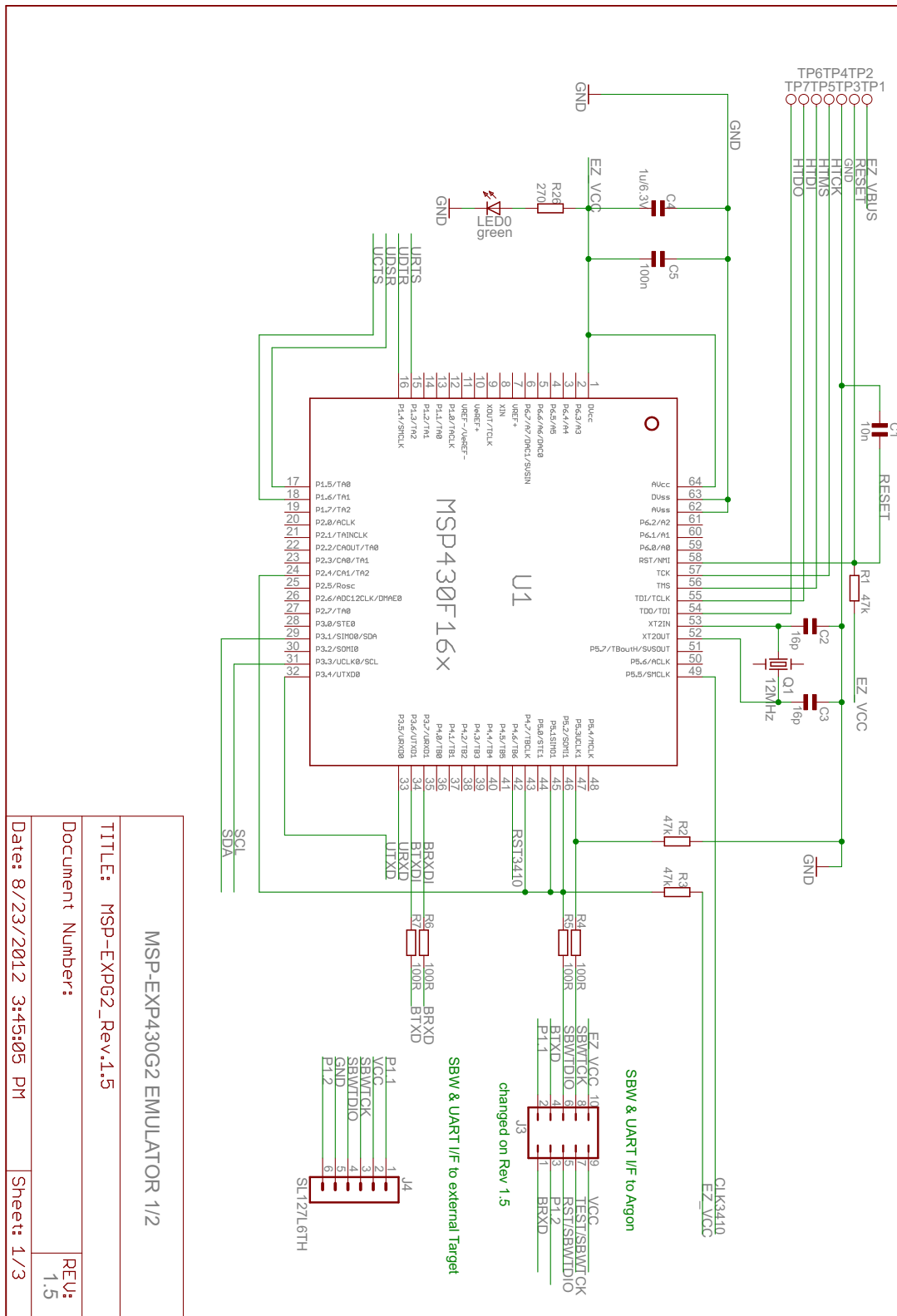

Figure 9. Schematics, MSP-EXP430G2 Emulator (1 of 2), Revision 1.5

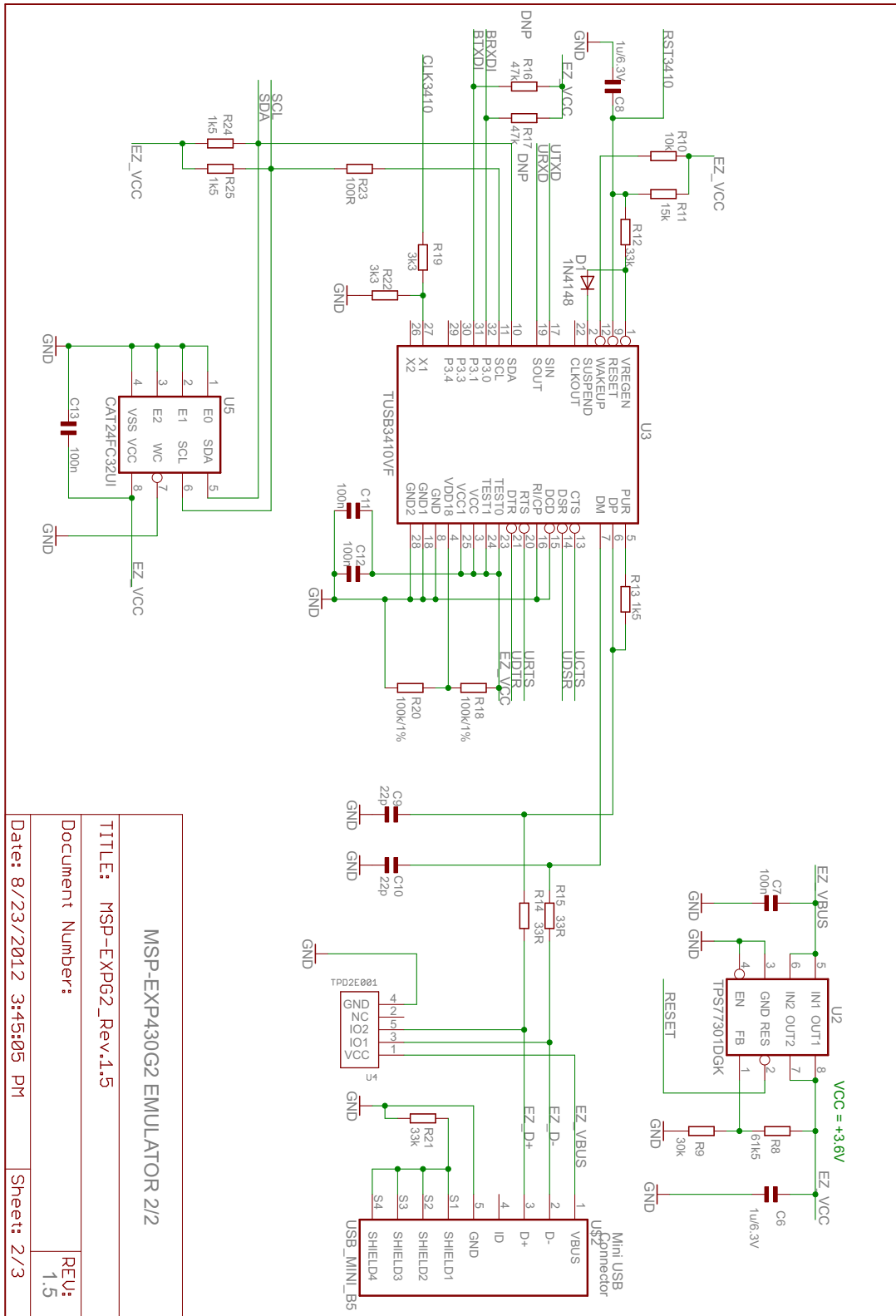

Figure 10. Schematics, MSP-EXP430G2 Emulator (2 of 2), Revision 1.5

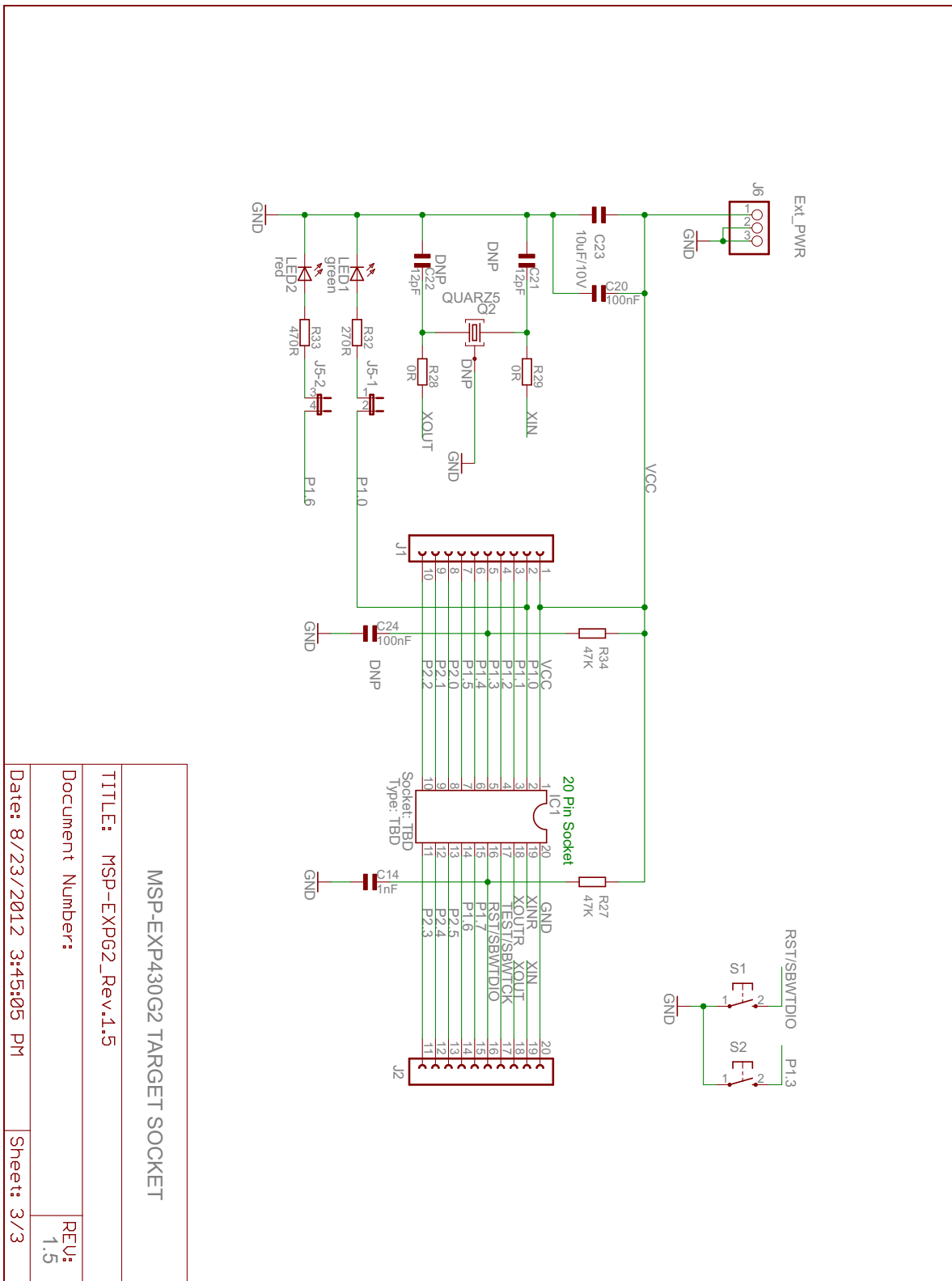

Figure 11. Schematics, MSP-EXP430G2 Target Socket, Revision 1.5

MSP-EXP430G2 TARGET SOCKET	
TITLE: MSP-EXP430G2_Rev.1.5	
Document Number:	
Date: 8/23/2012 3:45:05 PM	REV: 1.5
Sheet: 3/3	

5.3 PCB Layout

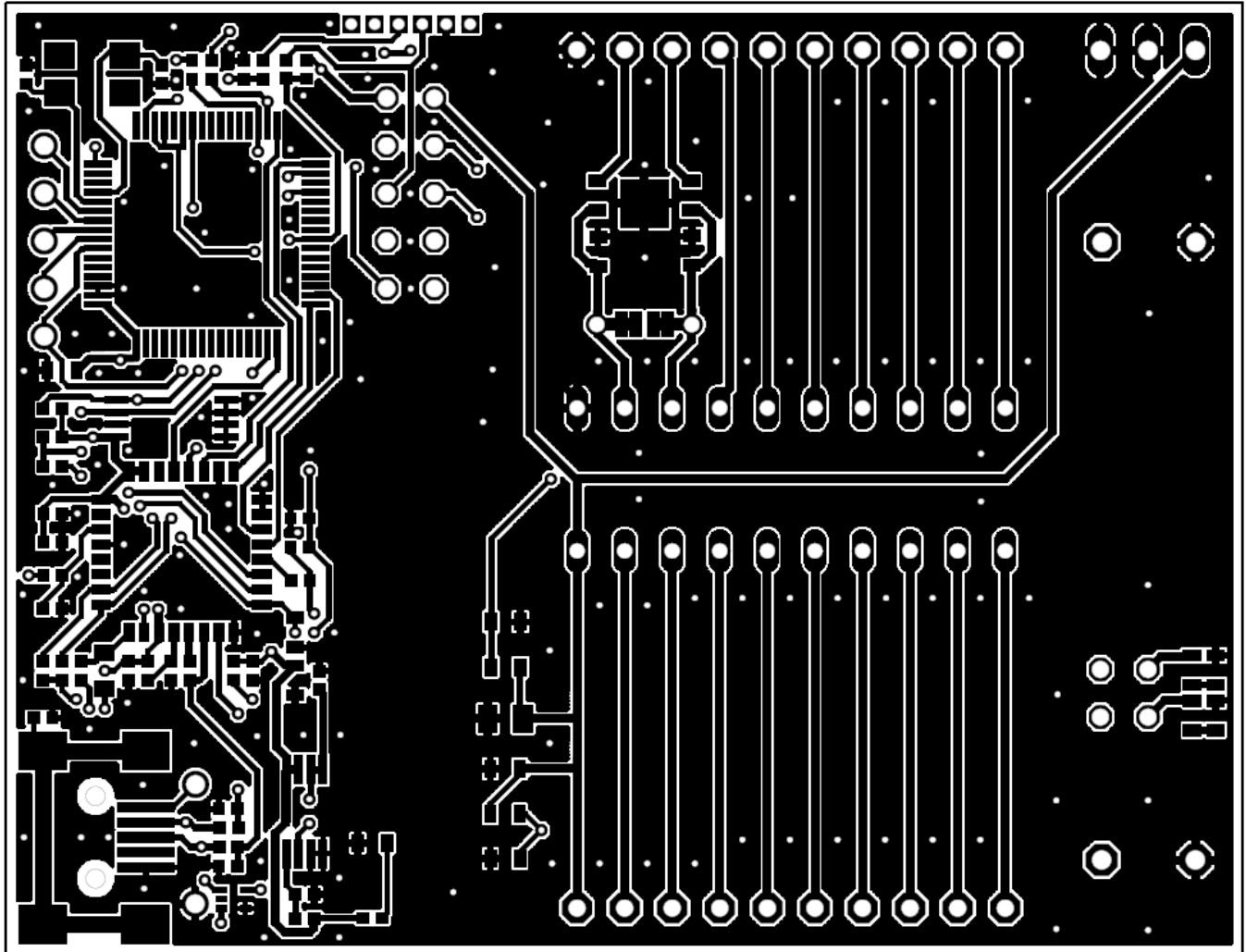

Figure 12. Layout, LaunchPad Top Layer

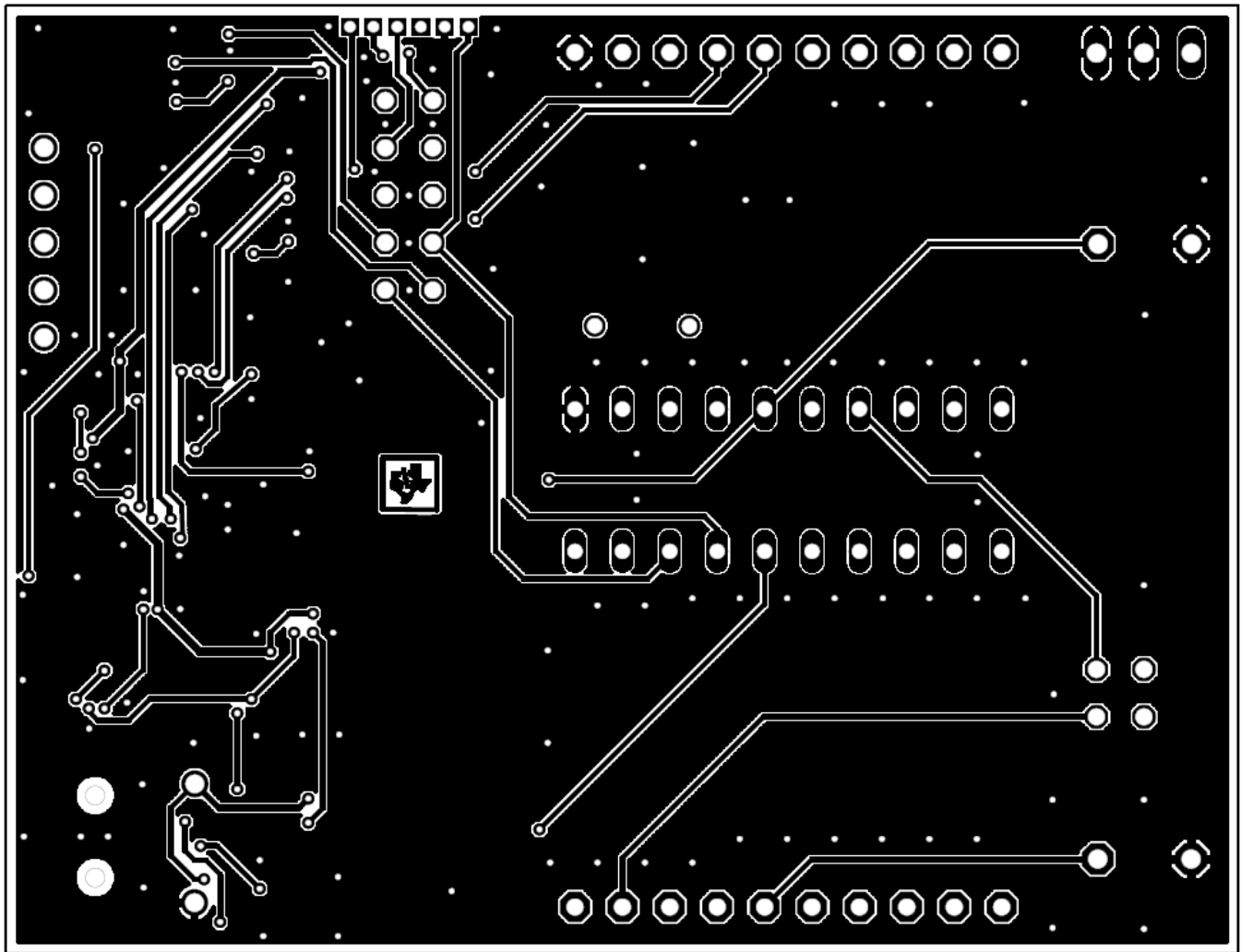

Figure 13. Layout, LaunchPad Bottom Layer

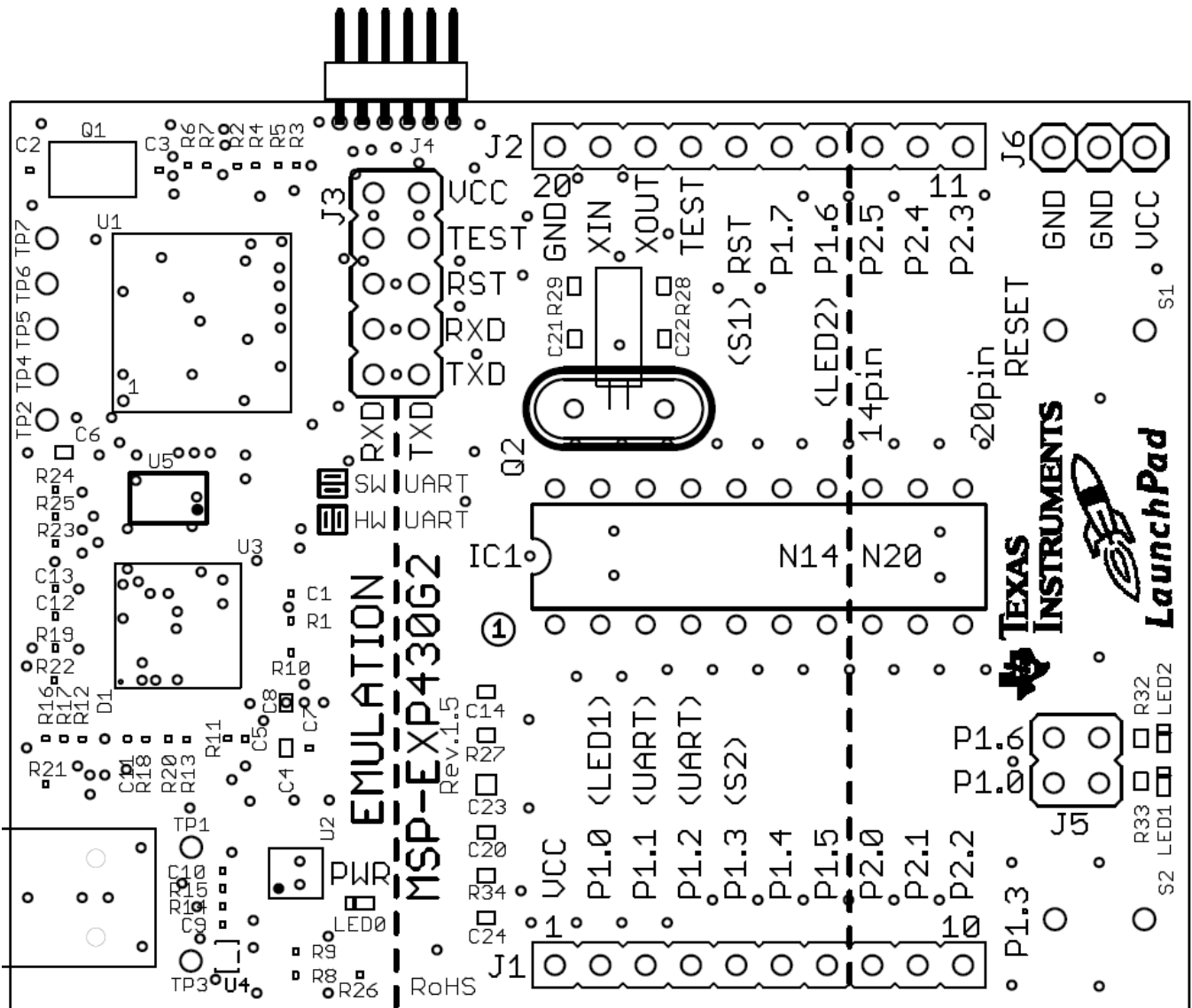

Figure 14. Layout, LaunchPad Silkscreen

5.4 Bill of Materials (BOM)

Table 5. Bill of Materials

Pos.	Ref Name	Number per Board	Description
1	C2, C3	2	16pF 0402 (33 pF on Rev 1.3)
2	C9, C10	2	22pF 0402
3	C1	1	10nF 0402
4	C5, C7, C11, C12, C13	5	100nF 0402
5	C4, C6, C8	3	1 μ F, 6.3V 0604
6	D1	1	1N4148 MicroMELF
7	EZ_USB	1	Mini-USB connector
8	Q1	1	SMD oscillator 12 MHz
9	R1, R2, R3, R16, R17	3	47k 0402 (R16, R17 is not populated)
10	R8	1	61k5 0402 (6k8 in Rev 1.3 and prior)
11	R19, R22	2	3k3 0402
12	R9	1	30k 0402 (3k3 in Rev 1.3 and prior)
13	R12, R21	2	33k 0402
14	R4, R5, R6, R7, R23	5	100R 0402
15	R14, R15	2	33R 0402
16	R18, R20	2	100k 0402
17	R13, R24, R25	3	1k5 0402
18	R10	1	10k 0402
19	R11	1	15k 0402
20	U1	1	MSP430F1612IPMR
21	U4	1	TPD2E001DRLR
22	U3	1	TUSB3410VF
23	U2	1	TPS77301DGKR
24	U5	1	I2C EEPROM 128k (AT24C128-10TU-2.7)
25	TP1, TP2, TP3, TP4, TP5, TP6, TP7		
26	C14	1	1nF, SMD 0603
27	C21, C22		12.5pF, SMD 0603 (not populated)
28	C23	1	10 μ F, 10 V, SMD 0805
29	C20, C24	1	100nF, SMD 0603 (C24 is not populated)
30	LED0, LED1	2	Green DIODE 0603
31	LED2	1	Red DIODE 0603
32	R34, R27	1	47k SMD 0603 (R34 is not populated)
33	R32, R26	2	270R SMD 0603
34	R33	1	470R SMD 0603
35	R28, R29	2	0R SMD 0603
36	IC1	1	DIP20 socket
37	Q2		Clock crystal 32kHz (Micro Crystal MS3V-T1R 32.768kHz CL:12.5pF \pm 20ppm included)
38	J1, J2,	2	10-pin header, TH, 2.54mm male (female header included)
39	J3	1	2X05 pin header male
40	J4		6 pin header male 1.28mm
41	J5	1	2x02 pin header male
42	J6	2	3-pin header, male, TH
43	S1, S2	2	Push button

6 Suggested Reading

The primary sources of MSP430™ information are the device-specific data sheets and the family user's guides. The most up-to-date versions of those documents can be found at the Texas Instruments MSP430 page or the MSP430 LaunchPad wiki.

<http://www.ti.com/msp430>, [http://processors.wiki.ti.com/index.php/MSP430_LaunchPad_\(MSP-EXP430G2\)](http://processors.wiki.ti.com/index.php/MSP430_LaunchPad_(MSP-EXP430G2))

To get an inside view of the supporting IDEs like CCS and IAR, download the latest version from the web pages above and read the included user's guides and documentation inside the installation folder. Documents describing the IAR tools (Workbench/C-SPY, the assembler, the C compiler, the linker, and the library) are located in common\doc and 430\doc. All necessary CCS documents can be found in the msp430\doc folder in the CCS installation path. The FET user's guide also includes detailed information on how to set up a project for the MSP430 using IAR or CCS, and it is included in most of the IDE releases and on the TI MSP430 side.

7 Frequently Asked Questions (FAQ)

1. Can other programming tools like the MSP-FET430UIF interface the MSP-EXP430G2 LaunchPad socket device?

The LaunchPad experimenter board works with any programming tool that supports the 2-wire Spy-Bi-Wire interface. Both the MSP430 USB FET (MSP-FET430UIF) and the Gang Programmer (MSP-GANG430) support these devices, but the connection must be made directly to the dedicated Spy-Bi-Wire ports. See *MSP-FET430 Flash Emulation Tool User's Guide* ([SLAU138](#)) for details on using MSP430 USB FET and the Gang Programmer for a 2-wire Spy-Bi-Wire interface. Do not try to connect the standard JTAG connector to the MSP-EXP430G2 pinheads, as this could result in damage to the attached hardware.

2. Does the MSP-EXP430G2 support fuse blow?

The MSP-EXP430G2 LaunchPad experimenter board onboard debugging interface lacks the JTAG security fuse-blow capability. To ensure firmware security on devices going to production, the USB Flash Emulation Tool or the Gang Production Programmer, which support the fuse-blow feature, are recommended.

3. What versions of IAR Embedded Workbench and Code Composer Studio are supported?

The MSP-EXP430 LaunchPad hardware is supported by IAR Embedded Workbench KickStart Version 6.00 or higher and Code Composer Studio v4 or higher. To download the software and for more information on the supported software visit the LaunchPad Wiki page.

[http://processors.wiki.ti.com/index.php/MSP430_LaunchPad_\(MSP-EXP430G2\)](http://processors.wiki.ti.com/index.php/MSP430_LaunchPad_(MSP-EXP430G2))

4. What are the part numbers for the connectors between the LaunchPad emulator board and the other eZ430 target boards?

Header: MALE CONN HEADER .050" 6POS PCB R/A (for example, Digi-Key: S9016E-06-ND)

Socket: FEMALE CONN HEADER .050" 6POS PCB R/A (for example, Digi-Key: S9010E-06-ND)

5. I am not able to select the MSP430 Application UART and cannot receive data.

Ensure that the Application UART driver is correctly installed. This is done by installing either IAR Embedded Workbench or Code Composer Studio v4.

To determine if the driver is correctly installed:

- a. Plug in the MSP-EXP430G2 LaunchPad with the included Mini USB cable.
- b. Right click My Computer and select Properties.
- c. Select the Hardware tab and click on Device Manager.
- d. Under Ports (COM & LPT) should be an entry for "MSP430 Application UART (COM xx)".

If the entry is there, but no characters are received, reconnect the LaunchPad to the PC and restart the application to reload the drivers. If the Application UART is not listed, install the driver by following the instructions in [Section 2.2](#).

6. The device is not answering to any communication, JTAG or UART.

If you are experiencing difficulties in communicating to the attached MSP430 target device, even though all the communication drivers for the MSP-EXP430G2 are loaded correctly, the emulator is probably set to a wrong communication state. This can be fixed by reconnecting the LaunchPad

Experimenter Board and restarting the communicating application. Also make sure that all the jumpers on J3 are connected properly between the emulator and the target device. On revision 1.5 and newer, the orientation of the UART jumpers must align with the software implementation on the target device.

7. I soldered the 32-kHz crystal to the board and the oscillation is not starting.

The MSP430 driving capabilities for the low-frequency crystal is limited, because it is designed for low-power applications. To ensure proper operation, the load on these pins must be as small as possible, the matching capacitors (12.5 pF for 32.768 kHz) for the crystal must be soldered to the board, and the resistors R28 and R29 must be removed. Measuring the frequency of the oscillation with an oscilloscope typically disturbs the oscillation.

8. The power consumption of the board is much higher than specified in the device data sheet, or I am not measuring a current at all.

The MSP430 device inside of the LaunchPad socket can be powered with an external power supply at header J6 or J4. To measure the power consumption in this mode, the VCC jumper, usually used to measure the power consumption, must be removed, and the current must be measured directly at the power supply. If the jumper J3 is not removed, the emulator circuitry of the LaunchPad is powered as well. Measuring the current consumption during a debug session is not possible, because the cross current through the JTAG connection influences the measurement. The most accurate results are achieved with all jumpers on J3 removed. If the measurement is still not matching the data sheet parameters, make sure that the code is aligned with all the power saving recommendations on the web site [MSP430™ - The World's Lowest Power MCU](#).

LaunchPad revisions 1.3 and 1.4 come with R34 populated. The 47-kΩ resistor is used as a pullup for the button S2. If the port P1.3 is driven to ground, as suggested to keep the power consumption down, the pullup resistor generates an additional current of approximately 77 μA. To reduce the power consumption, the port should stay in input mode or the resistor should be removed if button S2 is not used. The internal pullup of the MSP430G2xx can be used instead.

EVALUATION BOARD/KIT/MODULE (EVM) ADDITIONAL TERMS

Texas Instruments (TI) provides the enclosed Evaluation Board/Kit/Module (EVM) under the following conditions:

The user assumes all responsibility and liability for proper and safe handling of the goods. Further, the user indemnifies TI from all claims arising from the handling or use of the goods.

Should this evaluation board/kit not meet the specifications indicated in the User's Guide, the board/kit may be returned within 30 days from the date of delivery for a full refund. THE FOREGOING LIMITED WARRANTY IS THE EXCLUSIVE WARRANTY MADE BY SELLER TO BUYER AND IS IN LIEU OF ALL OTHER WARRANTIES, EXPRESSED, IMPLIED, OR STATUTORY, INCLUDING ANY WARRANTY OF MERCHANTABILITY OR FITNESS FOR ANY PARTICULAR PURPOSE. EXCEPT TO THE EXTENT OF THE INDEMNITY SET FORTH ABOVE, NEITHER PARTY SHALL BE LIABLE TO THE OTHER FOR ANY INDIRECT, SPECIAL, INCIDENTAL, OR CONSEQUENTIAL DAMAGES.

Please read the User's Guide and, specifically, the Warnings and Restrictions notice in the User's Guide prior to handling the product. This notice contains important safety information about temperatures and voltages. For additional information on TI's environmental and/or safety programs, please visit www.ti.com/esh or contact TI.

No license is granted under any patent right or other intellectual property right of TI covering or relating to any machine, process, or combination in which such TI products or services might be or are used. TI currently deals with a variety of customers for products, and therefore our arrangement with the user is not exclusive. TI assumes no liability for applications assistance, customer product design, software performance, or infringement of patents or services described herein.

REGULATORY COMPLIANCE INFORMATION

As noted in the EVM User's Guide and/or EVM itself, this EVM and/or accompanying hardware may or may not be subject to the Federal Communications Commission (FCC) and Industry Canada (IC) rules.

For EVMs **not** subject to the above rules, this evaluation board/kit/module is intended for use for ENGINEERING DEVELOPMENT, DEMONSTRATION OR EVALUATION PURPOSES ONLY and is not considered by TI to be a finished end product fit for general consumer use. It generates, uses, and can radiate radio frequency energy and has not been tested for compliance with the limits of computing devices pursuant to part 15 of FCC or ICES-003 rules, which are designed to provide reasonable protection against radio frequency interference. Operation of the equipment may cause interference with radio communications, in which case the user at his own expense will be required to take whatever measures may be required to correct this interference.

General Statement for EVMs including a radio

User Power/Frequency Use Obligations: This radio is intended for development/professional use only in legally allocated frequency and power limits. Any use of radio frequencies and/or power availability of this EVM and its development application(s) must comply with local laws governing radio spectrum allocation and power limits for this evaluation module. It is the user's sole responsibility to only operate this radio in legally acceptable frequency space and within legally mandated power limitations. Any exceptions to this are strictly prohibited and unauthorized by Texas Instruments unless user has obtained appropriate experimental/development licenses from local regulatory authorities, which is responsibility of user including its acceptable authorization.

For EVMs annotated as FCC – FEDERAL COMMUNICATIONS COMMISSION Part 15 Compliant

Caution

This device complies with part 15 of the FCC Rules. Operation is subject to the following two conditions: (1) This device may not cause harmful interference, and (2) this device must accept any interference received, including interference that may cause undesired operation.

Changes or modifications not expressly approved by the party responsible for compliance could void the user's authority to operate the equipment.

FCC Interference Statement for Class A EVM devices

This equipment has been tested and found to comply with the limits for a Class A digital device, pursuant to part 15 of the FCC Rules. These limits are designed to provide reasonable protection against harmful interference when the equipment is operated in a commercial environment. This equipment generates, uses, and can radiate radio frequency energy and, if not installed and used in accordance with the instruction manual, may cause harmful interference to radio communications. Operation of this equipment in a residential area is likely to cause harmful interference in which case the user will be required to correct the interference at his own expense.

FCC Interference Statement for Class B EVM devices

This equipment has been tested and found to comply with the limits for a Class B digital device, pursuant to part 15 of the FCC Rules. These limits are designed to provide reasonable protection against harmful interference in a residential installation. This equipment generates, uses and can radiate radio frequency energy and, if not installed and used in accordance with the instructions, may cause harmful interference to radio communications. However, there is no guarantee that interference will not occur in a particular installation. If this equipment does cause harmful interference to radio or television reception, which can be determined by turning the equipment off and on, the user is encouraged to try to correct the interference by one or more of the following measures:

- Reorient or relocate the receiving antenna.
- Increase the separation between the equipment and receiver.
- Connect the equipment into an outlet on a circuit different from that to which the receiver is connected.
- Consult the dealer or an experienced radio/TV technician for help.

For EVMs annotated as IC – INDUSTRY CANADA Compliant

This Class A or B digital apparatus complies with Canadian ICES-003.

Changes or modifications not expressly approved by the party responsible for compliance could void the user's authority to operate the equipment.

Concerning EVMs including radio transmitters

This device complies with Industry Canada licence-exempt RSS standard(s). Operation is subject to the following two conditions: (1) this device may not cause interference, and (2) this device must accept any interference, including interference that may cause undesired operation of the device.

Concerning EVMs including detachable antennas

Under Industry Canada regulations, this radio transmitter may only operate using an antenna of a type and maximum (or lesser) gain approved for the transmitter by Industry Canada. To reduce potential radio interference to other users, the antenna type and its gain should be so chosen that the equivalent isotropically radiated power (e.i.r.p.) is not more than that necessary for successful communication.

This radio transmitter has been approved by Industry Canada to operate with the antenna types listed in the user guide with the maximum permissible gain and required antenna impedance for each antenna type indicated. Antenna types not included in this list, having a gain greater than the maximum gain indicated for that type, are strictly prohibited for use with this device.

Cet appareil numérique de la classe A ou B est conforme à la norme NMB-003 du Canada.

Les changements ou les modifications pas expressément approuvés par la partie responsable de la conformité ont pu vider l'autorité de l'utilisateur pour actionner l'équipement.

Concernant les EVMs avec appareils radio

Le présent appareil est conforme aux CNR d'Industrie Canada applicables aux appareils radio exempts de licence. L'exploitation est autorisée aux deux conditions suivantes : (1) l'appareil ne doit pas produire de brouillage, et (2) l'utilisateur de l'appareil doit accepter tout brouillage radioélectrique subi, même si le brouillage est susceptible d'en compromettre le fonctionnement.

Concernant les EVMs avec antennes détachables

Conformément à la réglementation d'Industrie Canada, le présent émetteur radio peut fonctionner avec une antenne d'un type et d'un gain maximal (ou inférieur) approuvé pour l'émetteur par Industrie Canada. Dans le but de réduire les risques de brouillage radioélectrique à l'intention des autres utilisateurs, il faut choisir le type d'antenne et son gain de sorte que la puissance isotrope rayonnée équivalente (p.i.r.e.) ne dépasse pas l'intensité nécessaire à l'établissement d'une communication satisfaisante.

Le présent émetteur radio a été approuvé par Industrie Canada pour fonctionner avec les types d'antenne énumérés dans le manuel d'usage et ayant un gain admissible maximal et l'impédance requise pour chaque type d'antenne. Les types d'antenne non inclus dans cette liste, ou dont le gain est supérieur au gain maximal indiqué, sont strictement interdits pour l'exploitation de l'émetteur.

【Important Notice for Users of this Product in Japan】

This development kit is NOT certified as Confirming to Technical Regulations of Radio Law of Japan

If you use this product in Japan, you are required by Radio Law of Japan to follow the instructions below with respect to this product:

1. Use this product in a shielded room or any other test facility as defined in the notification #173 issued by Ministry of Internal Affairs and Communications on March 28, 2006, based on Sub-section 1.1 of Article 6 of the Ministry's Rule for Enforcement of Radio Law of Japan,
2. Use this product only after you obtained the license of Test Radio Station as provided in Radio Law of Japan with respect to this product, or
3. Use of this product only after you obtained the Technical Regulations Conformity Certification as provided in Radio Law of Japan with respect to this product. Also, please do not transfer this product, unless you give the same notice above to the transferee. Please note that if you could not follow the instructions above, you will be subject to penalties of Radio Law of Japan.

Texas Instruments Japan Limited
(address) 24-1, Nishi-Shinjuku 6 chome, Shinjuku-ku, Tokyo, Japan

<http://www.tij.co.jp>

【ご使用にあたっての注】

本開発キットは技術基準適合証明を受けておりません。

本製品のご使用に際しては、電波法遵守のため、以下のいずれかの措置を取っていただく必要がありますのでご注意ください。

1. 電波法施行規則第6条第1項第1号に基づく平成18年3月28日総務省告示第173号で定められた電波暗室等の試験設備でご使用いただく。
2. 実験局の免許を取得後ご使用いただく。
3. 技術基準適合証明を取得後ご使用いただく。

なお、本製品は、上記の「ご使用にあたっての注意」を譲渡先、移転先に通知しない限り、譲渡、移転できないものとします。

上記を遵守頂けない場合は、電波法の罰則が適用される可能性があることをご留意ください。

日本テキサス・インスツルメンツ株式会社
東京都新宿区西新宿6丁目24番1号
西新宿三井ビル

<http://www.tij.co.jp>

EVALUATION BOARD/KIT/MODULE (EVM) WARNINGS, RESTRICTIONS AND DISCLAIMERS

For Feasibility Evaluation Only, in Laboratory/Development Environments. Unless otherwise indicated, this EVM is not a finished electrical equipment and not intended for consumer use. It is intended solely for use for preliminary feasibility evaluation in laboratory/development environments by technically qualified electronics experts who are familiar with the dangers and application risks associated with handling electrical mechanical components, systems and subsystems. It should not be used as all or part of a finished end product.

Your Sole Responsibility and Risk. You acknowledge, represent and agree that:

1. You have unique knowledge concerning Federal, State and local regulatory requirements (including but not limited to Food and Drug Administration regulations, if applicable) which relate to your products and which relate to your use (and/or that of your employees, affiliates, contractors or designees) of the EVM for evaluation, testing and other purposes.
2. You have full and exclusive responsibility to assure the safety and compliance of your products with all such laws and other applicable regulatory requirements, and also to assure the safety of any activities to be conducted by you and/or your employees, affiliates, contractors or designees, using the EVM. Further, you are responsible to assure that any interfaces (electronic and/or mechanical) between the EVM and any human body are designed with suitable isolation and means to safely limit accessible leakage currents to minimize the risk of electrical shock hazard.
3. You will employ reasonable safeguards to ensure that your use of the EVM will not result in any property damage, injury or death, even if the EVM should fail to perform as described or expected.
4. You will take care of proper disposal and recycling of the EVM's electronic components and packing materials.

Certain Instructions. It is important to operate this EVM within TI's recommended specifications and environmental considerations per the user guidelines. Exceeding the specified EVM ratings (including but not limited to input and output voltage, current, power, and environmental ranges) may cause property damage, personal injury or death. If there are questions concerning these ratings please contact a TI field representative prior to connecting interface electronics including input power and intended loads. Any loads applied outside of the specified output range may result in unintended and/or inaccurate operation and/or possible permanent damage to the EVM and/or interface electronics. Please consult the EVM User's Guide prior to connecting any load to the EVM output. If there is uncertainty as to the load specification, please contact a TI field representative. During normal operation, some circuit components may have case temperatures greater than 60°C as long as the input and output are maintained at a normal ambient operating temperature. These components include but are not limited to linear regulators, switching transistors, pass transistors, and current sense resistors which can be identified using the EVM schematic located in the EVM User's Guide. When placing measurement probes near these devices during normal operation, please be aware that these devices may be very warm to the touch. As with all electronic evaluation tools, only qualified personnel knowledgeable in electronic measurement and diagnostics normally found in development environments should use these EVMs.

Agreement to Defend, Indemnify and Hold Harmless. You agree to defend, indemnify and hold TI, its licensors and their representatives harmless from and against any and all claims, damages, losses, expenses, costs and liabilities (collectively, "Claims") arising out of or in connection with any use of the EVM that is not in accordance with the terms of the agreement. This obligation shall apply whether Claims arise under law of tort or contract or any other legal theory, and even if the EVM fails to perform as described or expected.

Safety-Critical or Life-Critical Applications. If you intend to evaluate the components for possible use in safety critical applications (such as life support) where a failure of the TI product would reasonably be expected to cause severe personal injury or death, such as devices which are classified as FDA Class III or similar classification, then you must specifically notify TI of such intent and enter into a separate Assurance and Indemnity Agreement.

Mailing Address: Texas Instruments, Post Office Box 655303, Dallas, Texas 75265
Copyright © 2012, Texas Instruments Incorporated

IMPORTANT NOTICE

Texas Instruments Incorporated and its subsidiaries (TI) reserve the right to make corrections, enhancements, improvements and other changes to its semiconductor products and services per JESD46C and to discontinue any product or service per JESD48B. Buyers should obtain the latest relevant information before placing orders and should verify that such information is current and complete. All semiconductor products (also referred to herein as "components") are sold subject to TI's terms and conditions of sale supplied at the time of order acknowledgment.

TI warrants performance of its components to the specifications applicable at the time of sale, in accordance with the warranty in TI's terms and conditions of sale of semiconductor products. Testing and other quality control techniques are used to the extent TI deems necessary to support this warranty. Except where mandated by applicable law, testing of all parameters of each component is not necessarily performed.

TI assumes no liability for applications assistance or the design of Buyers' products. Buyers are responsible for their products and applications using TI components. To minimize the risks associated with Buyers' products and applications, Buyers should provide adequate design and operating safeguards.

TI does not warrant or represent that any license, either express or implied, is granted under any patent right, copyright, mask work right, or other intellectual property right relating to any combination, machine, or process in which TI components or services are used. Information published by TI regarding third-party products or services does not constitute a license to use such products or services or a warranty or endorsement thereof. Use of such information may require a license from a third party under the patents or other intellectual property of the third party, or a license from TI under the patents or other intellectual property of TI.

Reproduction of significant portions of TI information in TI data books or data sheets is permissible only if reproduction is without alteration and is accompanied by all associated warranties, conditions, limitations, and notices. TI is not responsible or liable for such altered documentation. Information of third parties may be subject to additional restrictions.

Resale of TI components or services with statements different from or beyond the parameters stated by TI for that component or service voids all express and any implied warranties for the associated TI component or service and is an unfair and deceptive business practice. TI is not responsible or liable for any such statements.

Buyer acknowledges and agrees that it is solely responsible for compliance with all legal, regulatory and safety-related requirements concerning its products, and any use of TI components in its applications, notwithstanding any applications-related information or support that may be provided by TI. Buyer represents and agrees that it has all the necessary expertise to create and implement safeguards which anticipate dangerous consequences of failures, monitor failures and their consequences, lessen the likelihood of failures that might cause harm and take appropriate remedial actions. Buyer will fully indemnify TI and its representatives against any damages arising out of the use of any TI components in safety-critical applications.

In some cases, TI components may be promoted specifically to facilitate safety-related applications. With such components, TI's goal is to help enable customers to design and create their own end-product solutions that meet applicable functional safety standards and requirements. Nonetheless, such components are subject to these terms.

No TI components are authorized for use in FDA Class III (or similar life-critical medical equipment) unless authorized officers of the parties have executed a special agreement specifically governing such use.

Only those TI components which TI has specifically designated as military grade or "enhanced plastic" are designed and intended for use in military/aerospace applications or environments. Buyer acknowledges and agrees that any military or aerospace use of TI components which have **not** been so designated is solely at the Buyer's risk, and that Buyer is solely responsible for compliance with all legal and regulatory requirements in connection with such use.

TI has specifically designated certain components which meet ISO/TS16949 requirements, mainly for automotive use. Components which have not been so designated are neither designed nor intended for automotive use; and TI will not be responsible for any failure of such components to meet such requirements.

Products

Audio	www.ti.com/audio
Amplifiers	amplifier.ti.com
Data Converters	dataconverter.ti.com
DLP® Products	www.dlp.com
DSP	dsp.ti.com
Clocks and Timers	www.ti.com/clocks
Interface	interface.ti.com
Logic	logic.ti.com
Power Mgmt	power.ti.com
Microcontrollers	microcontroller.ti.com
RFID	www.ti-rfid.com
OMAP Mobile Processors	www.ti.com/omap
Wireless Connectivity	www.ti.com/wirelessconnectivity

Applications

Automotive and Transportation	www.ti.com/automotive
Communications and Telecom	www.ti.com/communications
Computers and Peripherals	www.ti.com/computers
Consumer Electronics	www.ti.com/consumer-apps
Energy and Lighting	www.ti.com/energy
Industrial	www.ti.com/industrial
Medical	www.ti.com/medical
Security	www.ti.com/security
Space, Avionics and Defense	www.ti.com/space-avionics-defense
Video and Imaging	www.ti.com/video

TI E2E Community e2e.ti.com