

## Silicon Spreading Resistance Temperature Sensor in Leaded Plastic Package

**KT 100**  
**KTY 10**

### Features

- Temperature dependent Resistor with Positive Temperature Coefficient
- Small plastic package
- Fast response
- High reliability due to multilayer gold contacts
- n-conducting silicon crystal
- Polarity independent due to symmetrical construction
- Available selected in  $\pm 1\%$  tolerance groups

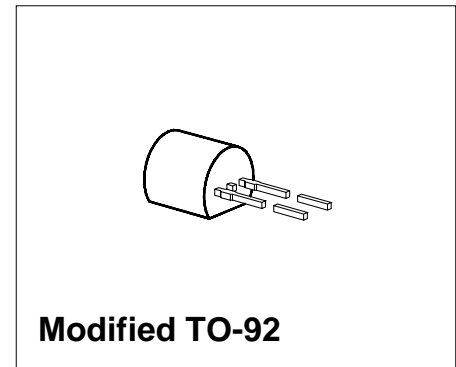

### Electrical Characteristics

at  $T_A = 25\text{ }^\circ\text{C}$  unless otherwise specified

Parameter	Symbol	Limit Values			Unit
		min.	typ.	max.	
Temperature sensor resistance $I_B = 1\text{ mA}$ KT 100 KTY 10-5 KTY 10-6 KTY 10-62 KT 10-7	$R_{25}$	1940 1950 1980 1990 2010	— — — — —	2060 1990 2020 2010 2050	$\Omega$
Thermal time constant (63% of $\Delta T_A$ ) in still air in still oil (Freon FC40/PP7)	$\tau_{\text{air}}$ $\tau_{\text{oil}}$	— —	40 4	— —	s

Type	Marking	Ordering Code	Pin Configuration		Package
			1	2	
KT 100	KT 100	Q62705-K331	electrical contact	electrical contact	Modified TO-92
KTY 10-5	KTY 10-5	Q62705-K110			
KTY 10-6	KTY 10-6	Q62705-K132			
KTY 10-62	KTY 10-62	Q62705-K71			
KTY 10-7	KTY 10-7	Q62705-K111			

## Absolute Maximum Ratings

Parameter	Symbol	Limit Values	Unit
Maximum operating voltage <sup>1)</sup> $T_A \leq 25\text{ °C}, t \leq 10\text{ ms}$	$V_{opmax}$	25	V
Maximum operating current	$I_{opmax}$	7	mA
Peak operating current $T_A \leq 25\text{ °C}, t \leq 10\text{ ms}$	$I_{opp}$	10	mA
Operating temperature range	$T_{op}$	- 50 ... + 150	°C
Storage temperature range	$T_{stg}$	- 50 ... + 150	°C

<sup>1)</sup> ESD Class 1. When the temperature sensor is operated with long supply leads, it should be protected through the parallel connection of a > 10 nF capacitor to prevent damage to the sensor through induced voltage peaks.

## Package Outline

### Modified TO-92

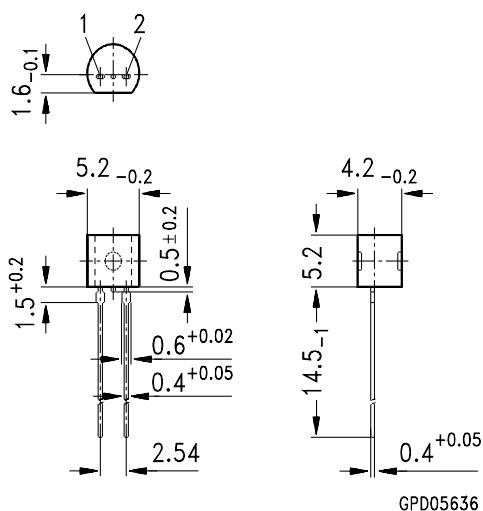

Weight approx. 0.25 g

Dimensions in mm

## Exterior Packaging

I.e. tubes, trays, boxes are shown in our Data Book "Package Information".