

Silicon Tuning Diode

- High Q hyperabrupt dual tuning diode
- Designed for low tuning voltage operation
- For VCO's in mobile communications equipment

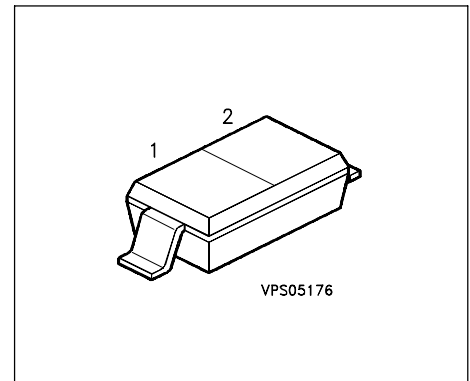

Type	Marking	Ordering Code	Pin Configuration			Package
BBY 52-03W	I (white)	Q62702-B664	1 = C	2 = A	-	SOD-323

Maximum Ratings

Parameter	Symbol	Values	Unit
Diode reverse voltage	V_R	7	V
Forward current	I_F	20	mA
Operating temperature range	T_{op}	- 55 ... + 150	°C
Storage temperature	T_{stg}	- 55 ... + 150	

Electrical Characteristics at $T_A=25^\circ\text{C}$, unless otherwise specified

Parameter	Symbol	Values			Unit
		min.	typ.	max.	
DC characteristics					
Reverse current	I_R				nA
$V_R = 6\text{ V}, T_A = 25^\circ\text{C}$		-	-	10	
$V_R = 6\text{ V}, T_A = 65^\circ\text{C}$		-	-	200	

AC characteristics

Diode capacitance	C_T				pF
$V_R = 1\text{ V}, f = 1\text{ MHz}$		1.4	1.85	2.2	
$V_R = 2\text{ V}, f = 1\text{ MHz}$		-	1.5	-	
$V_R = 3\text{ V}, f = 1\text{ MHz}$		-	1.35	-	
$V_R = 4\text{ V}, f = 1\text{ MHz}$		0.85	1.15	1.45	
Capacitance ratio	C_{T1}/C_{T4}				-
$V_R = 1\text{ V}, V_R = 4\text{ V}, f = 1\text{ MHz}$		1.1	1.6	2.1	
Series resistance	r_s				Ω
$V_R = 1\text{ V}, f = 1\text{ GHz}$		-	0.9	1.8	
Case capacitance	C_C				pF
$f = 1\text{ MHz}$		-	0.12	-	
Series inductance chip to ground	L_s				nH
		-	1.8	-	

Diode capacitance $C_T = f(V_R)$

$f = 1\text{MHz}$

