

System Motor Driver ICs for CD/DVD Players

# 1ch Spindle Motor Driver ICs

**BA6859AFP-Y,BA6664FM,BD6671FM**

No.10011EAT03

## ●Description

ROHM's spindle motor drivers incorporate the 3-phase full-wave pseudo-linear drive system(BA6859AFP-Y, BA6664FM) and 180° electrifying direct PWM drive system(BD6671FM).Smooth rotation characteristic performance is ensured. Besides, high torque is provided in a wide output range because the output stage incorporates low-saturation voltage NPN transistors (BA6859AFP-Y, BA6664FM) and low-power consumption MOSFET (BA6671FM).

## ●Features

- 1) 3-phase full-wave pseudo-linear system (BA6859AFP-Y, BA6664FM)
- 2) 180° electrifying direct drive PWM system (BD6671FM)
- 3) Power saving, TSD (thermal shutdown) functions built in
- 4) Current limiting, Hall bias circuit built in
- 5) FG output built in
- 6) 3-phase component FG output built in (BA6664FM, BD6671FM)
- 7) Circuit direction detection function built in (BA6859AFP-Y, BA6664FM)
- 8) Reverse rotation prevention circuit built in
- 9) Short brake pin built in (BA6859AFP-Y, BA6664FM)
- 10) Brake mode selection pin built in (BA6859AFP-Y, BD6671FM)
- 11) Supports DSP 3.3 V

## ●Applications

Used for car, CD and DVD players incorporating changer function

## ●Absolute maximum ratings (Ta=25°C)

Parameter	Symbol	Ratings			Unit
		BA6859AFP-Y	BA6664FM	BD6671FM	
Applied voltage	V <sub>CC</sub>	7	7	7	V
Applied voltage	V <sub>M</sub>	15	15	15	V
Applied voltage	V <sub>G</sub>	-	-	20	V
Power dissipation	P <sub>d</sub>	1450 <sup>*1</sup>	2200 <sup>*2</sup>	2200 <sup>*2</sup>	mW
Operating temperature	T <sub>opr</sub>	-40~+85	-40~+85	-40~+85	°C
Storage temperature	T <sub>stg</sub>	-55~+150	-55~+150	-55~+150	°C
Output current	I <sub>out</sub>	1300	1300	2500	mA
Junction temperature	T <sub>jmax</sub>	150	150	150	°C

\*1 Reduced by 11.6 mW/°C over 25°C, when mounted on a glass epoxy board (70 mm x 70 mm x 1.6 mm).

\*2 Reduced by 17.6 mW/°C over 25°C, when mounted on a glass epoxy board (70 mm x 70 mm x 1.6 mm).

## ●Line up matrix

Parameter	Symbol	Ratings			Unit
		BA6859AFP-Y	BA6664FM	BD6671FM	
Power supply voltage	V <sub>CC</sub>	4.5~5.5	4.5~5.5	4.5~5.5	V
	V <sub>M</sub>	3.0~14	3.0~14	4.0~13.2	V
VG pin voltage	V <sub>G</sub>	-	-	8.5~19	V

●Electrical characteristics

1) BA6859AFP-Y (Unless otherwise specified, Ta=25°C, V<sub>CC</sub>=5.0V, V<sub>M</sub>=12V)

Parameter	Symbol	Limits			Unit	Conditions
		Min.	Typ.	Max.		
<Total device>						
Circuit current 1	I <sub>CC1</sub>	—	0	0.2	mA	PS=L
Circuit current 2	I <sub>CC2</sub>	—	5.0	7.5	mA	PS=H
<Power-saving >						
ON voltage range	V <sub>PSON</sub>	—	—	1.0	V	Internal circuit OFF
OFF voltage range	V <sub>PSOFF</sub>	2.5	—	—	V	Internal circuit ON
<Hall bias>						
Hall bias voltage	V <sub>HB</sub>	0.5	0.9	1.5	V	I <sub>HB</sub> =10mA
<Hall amp>						
Input bias current	I <sub>HA</sub>	—	0.7	3.0	μA	
Same phase input voltage range	V <sub>HAR</sub>	1.0	—	4.0	V	
Mini. input level	V <sub>INH</sub>	50	—	—	mVpp	One side input level
H3 hysteresis level	V <sub>HYS</sub>	5	20	40	mV	
<Torque Command >						
Input voltage range	E <sub>C</sub> , E <sub>CR</sub>	0	—	5	V	Linear range:0.5~3.3V
Offset voltage -	E <sub>COFF-</sub>	-80	-50	-20	mV	E <sub>CR</sub> =1.9V
Offset voltage +	E <sub>COFF+</sub>	20	50	80	mV	E <sub>CR</sub> =1.9V
Input bias current	E <sub>CIN</sub>	-3	—	3	μA	E <sub>C</sub> =E <sub>CR</sub>
I/O gain	G <sub>EC</sub>	0.56	0.70	0.84	A/V	E <sub>C</sub> =1.2, 1.7V
<FG>						
FG output high-level voltage	V <sub>FGH</sub>	4.5	4.8	—	V	I <sub>FG</sub> =-20μA
FG output low-level voltage	V <sub>FGL</sub>	—	0.25	0.4	V	I <sub>FG</sub> =3.0mA
Duty (reference values)	D <sub>U</sub>	—	50	—	%	
<Rotation Detection>						
FR output high-level voltage	V <sub>FRH</sub>	4.1	4.4	—	V	I <sub>FR</sub> =-20μA
FR output low-level voltage	V <sub>FRL</sub>	—	0.25	0.4	V	I <sub>FR</sub> =3.0mA
<Output>						
Output saturation high level voltage	V <sub>OH</sub>	—	1.0	1.4	V	I <sub>O</sub> =-600mA
Output saturation low level voltage	V <sub>OL</sub>	—	0.4	0.7	V	I <sub>O</sub> =600mA
Pre-drive current	I <sub>VML</sub>	—	35	70	mA	E <sub>C</sub> =0V output open
Output limit current	I <sub>TL</sub>	560	700	840	mA	
<Short brake >						
ON voltage range	V <sub>SBON</sub>	2.5	—	—	V	BR=0V
OFF voltage range	V <sub>SBOFF</sub>	—	—	1.0	V	BR=0V
<Brake mode >						
ON voltage range	V <sub>BRON</sub>	2.5	—	—	V	E <sub>C</sub> >E <sub>CR</sub> , SB=Open
OFF voltage range	V <sub>BROFF</sub>	—	—	1.0	V	E <sub>C</sub> >E <sub>CR</sub> , SB=Open

●Reference: Data

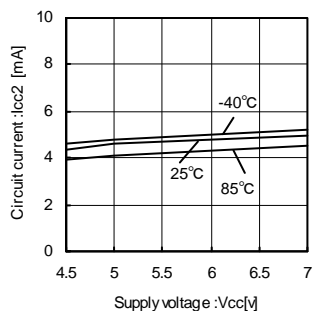

Fig.1 Circuit Current 2

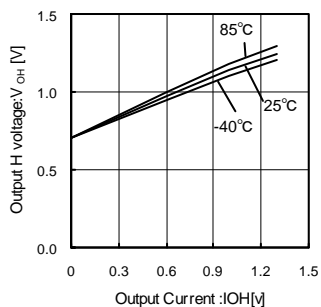

Fig.2 Output Saturation Voltage at High Level

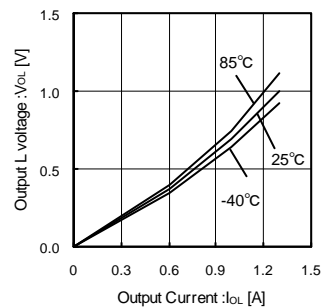

Fig.3 Output Saturation Voltage at Low Level

2) BA6664FM(Unless otherwise specified, Ta=25°C, V<sub>CC</sub>=5.0V, V<sub>M</sub>=12V)

Parameter	Symbol	Limits			Unit	Conditions
		Min.	Typ.	Max.		
<Total device>						
Circuit current 1	I <sub>CC1</sub>	—	0	0.2	mA	PS=L, GSW=Open
Circuit current 2	I <sub>CC2</sub>	—	6.2	9.1	mA	PS=H, GSW=Open
<Power-saving >						
ON voltage range	V <sub>PSON</sub>	—	—	1.0	V	Internal current circuit OFF
OFF voltage range	V <sub>PSOFF</sub>	2.5	—	—	V	Internal current circuit ON
<Hall bias>						
Hall bias voltage	V <sub>HB</sub>	0.5	0.9	1.5	V	I <sub>HB</sub> =10mA
<Hall amp>						
Input bias current	I <sub>HA</sub>	—	0.7	3.0	μA	
Same phase input voltage range	V <sub>HAR</sub>	1.0	—	4.0	V	
Mini. input level	V <sub>INH</sub>	50	—	—	mVpp	One side input level
H3 hysteresis level	V <sub>HYS</sub>	5	20	40	mV	
<Torque Command >						
Input voltage range	E <sub>C</sub> , E <sub>CR</sub>	0	—	5	V	Linear range:0.5~3.3V
Offset voltage -	E <sub>COFF-</sub>	-75	-45	-15	mV	E <sub>CR</sub> =1.65V, GSW=L
Offset voltage +	E <sub>COFF+</sub>	15	45	75	mV	E <sub>CR</sub> =1.65V, GSW=L
Input bias current	E <sub>CIN</sub>	-3	—	3	μA	E <sub>C</sub> =E <sub>CR</sub>
I/O gain low-level	G <sub>ECL</sub>	0.52	0.65	0.78	A/V	GSW=L,RNF=0.5Ω
I/O gain medium-level	G <sub>ECM</sub>	1.04	1.3	1.56	A/V	GSW=OPEN,RNF=0.5Ω
I/O gain high-level	G <sub>ECH</sub>	2.24	2.8	3.36	A/V	GSW=H,RNF=0.5Ω
<FG>						
FG output high-level voltage	V <sub>FGH</sub>	4.5	4.8	—	V	I <sub>FG</sub> =-20μA
FG output low-level voltage	V <sub>FGL</sub>	—	0.2	0.4	V	I <sub>FG</sub> =3.0mA
<FG2>						
FG output high-level voltage	V <sub>FG2H</sub>	4.6	4.9	—	V	I <sub>FG2</sub> =-20μA
FG output low-level voltage	V <sub>FG2L</sub>	—	0.2	0.4	V	I <sub>FG2</sub> =3mA
<Rotation Detection>						
FR output high-level voltage	V <sub>FRH</sub>	4.1	4.4	—	V	I <sub>FR</sub> =-20μA
FR output low-level voltage	V <sub>FRL</sub>	—	0.2	0.4	V	I <sub>FR</sub> =3.0mA
<Output>						
Output saturation high-level voltage	V <sub>OH</sub>	—	1.0	1.35	V	I <sub>OUT</sub> =-600mA
Output saturation low-level voltage	V <sub>OL</sub>	—	0.4	0.65	V	I <sub>OUT</sub> =600mA
Pre-drive current	I <sub>VML</sub>	—	35	70	mA	E <sub>C</sub> =0V output open
Output limit current	I <sub>TL</sub>	560	700	840	mA	
<Short brake >						
ON voltage range	V <sub>SBON</sub>	2.5	—	—	V	BR=0V
OFF voltage range	V <sub>SBOFF</sub>	—	—	1.0	V	BR=0V
<Brake mode >						
ON voltage range	V <sub>BROFF</sub>	2.5	—	—	V	E <sub>C</sub> >E <sub>CR</sub> , SB=Open
OFF voltage range	V <sub>BROFF</sub>	—	—	1.0	V	E <sub>C</sub> >E <sub>CR</sub> , SB=Open
<Gain switching >						
Low voltage range	V <sub>GSWL</sub>	—	—	1.0	V	
High voltage range	V <sub>GSWH</sub>	3.0	—	—	V	
OPEN voltage	V <sub>GSWOP</sub>	—	2.0	—	V	

3) BD6671FM (Unless otherwise specified, Ta=25°C, V<sub>CC</sub>=5.0V, V<sub>M</sub>=12V)

Parameter	Symbol	Limits			Unit	Conditions
		Min.	Typ.	Max.		
<Total device>						
Circuit current 1	I <sub>CC1</sub>	—	100	200	μA	PS=L, GSW=Open
Circuit current 2	I <sub>CC2</sub>	8	14	20	mA	PS=H, GSW=Open
<Power-saving >						
ON voltage range	V <sub>PSON</sub>	—	—	1.0	V	Internal current circuit OFF
OFF voltage range	V <sub>PSOFF</sub>	2.5	—	—	V	Internal current circuit ON
<Hall bias>						
Hall bias voltage	V <sub>HB</sub>	0.7	1.0	1.3	V	I <sub>HB</sub> =10mA
<Hall amp>						
Same phase input voltage range	V <sub>HAR</sub>	1.4	—	3.6	V	
Mini. input level	V <sub>INH</sub>	100	—	—	mVpp	Both side input level
Hall hysteresis level +	V <sub>HYS+</sub>	5	20	40	mV	
Hall hysteresis level -	V <sub>HYS-</sub>	-40	-20	-5	mV	
<Gain switching >						
Low voltage range	V <sub>GSWL</sub>	—	—	0.6	V	
High voltage range	V <sub>GSWH</sub>	2.0	—	—	V	
OPEN voltage range	V <sub>GSWOP</sub>	—	1.3	—	V	
<Torque Command >						
Input voltage range	E <sub>C</sub> , E <sub>CR</sub>	0	—	5	V	Linear range: 0.5~3.0V
Offset voltage +	E <sub>COFF+</sub>	5	50	100	mV	GSW=M
Offset voltage -	E <sub>COFF-</sub>	-100	-50	5	mV	GSW=M
Input current	E <sub>CIN</sub>	-11	-2.5	0	μA	E <sub>C</sub> =E <sub>CR</sub> =1.65V
I/O gain low-level	G <sub>ECL</sub>	0.28	0.35	0.42	A/V	GSW=L
I/O gain medium-level	G <sub>ECM</sub>	0.56	0.70	0.84	A/V	GSW=M
I/O gain high-level	G <sub>ECH</sub>	1.12	1.40	1.68	A/V	GSW=H
<Output>						
Output ON resistance	R <sub>ON</sub>	—	1.0	1.35	Ω	I <sub>OUT</sub> =±600mA (upper + lower side)
Output limit current low-level	I <sub>TLL</sub>	340	400	460	mA	GSW=L
Output limit current medium-level	I <sub>TLM</sub>	680	800	920	mA	GSW=M
Output limit current high-level	I <sub>TLH</sub>	1020	1200	1380	mA	GSW=H
<FG/FG3 output >						
High level voltage	V <sub>FGH</sub>	4.6	—	—	V	I <sub>FG</sub> =-100μA
Low level voltage	V <sub>FGL</sub>	—	—	0.4	V	I <sub>FG</sub> =+100μA
<Booster voltage >						
Charge pump output voltage	V <sub>PUMP</sub>	12.5	17	19	V	V <sub>CC</sub> = 5V, V <sub>M</sub> =12V CP1=CP2=0.1μF
<CP1 output >						
Upper side saturation voltage	V <sub>CP1H</sub>	0.25	0.45	0.65	V	I <sub>CP1</sub> =-4mA
Lower side saturation voltage	V <sub>CP1L</sub>	0.2	0.4	0.6	V	I <sub>CP1</sub> =+4mA
<CP2 output >						
Upper side saturation voltage	V <sub>CP2H</sub>	0.4	0.6	0.8	V	I <sub>CP2</sub> =-4mA
Lower side saturation voltage	V <sub>CP2L</sub>	0.15	0.35	0.55	V	I <sub>CP2</sub> =+4mA

●Block Diagram, application Circuit Diagram and Pin Function

1)BA6859AFP-Y

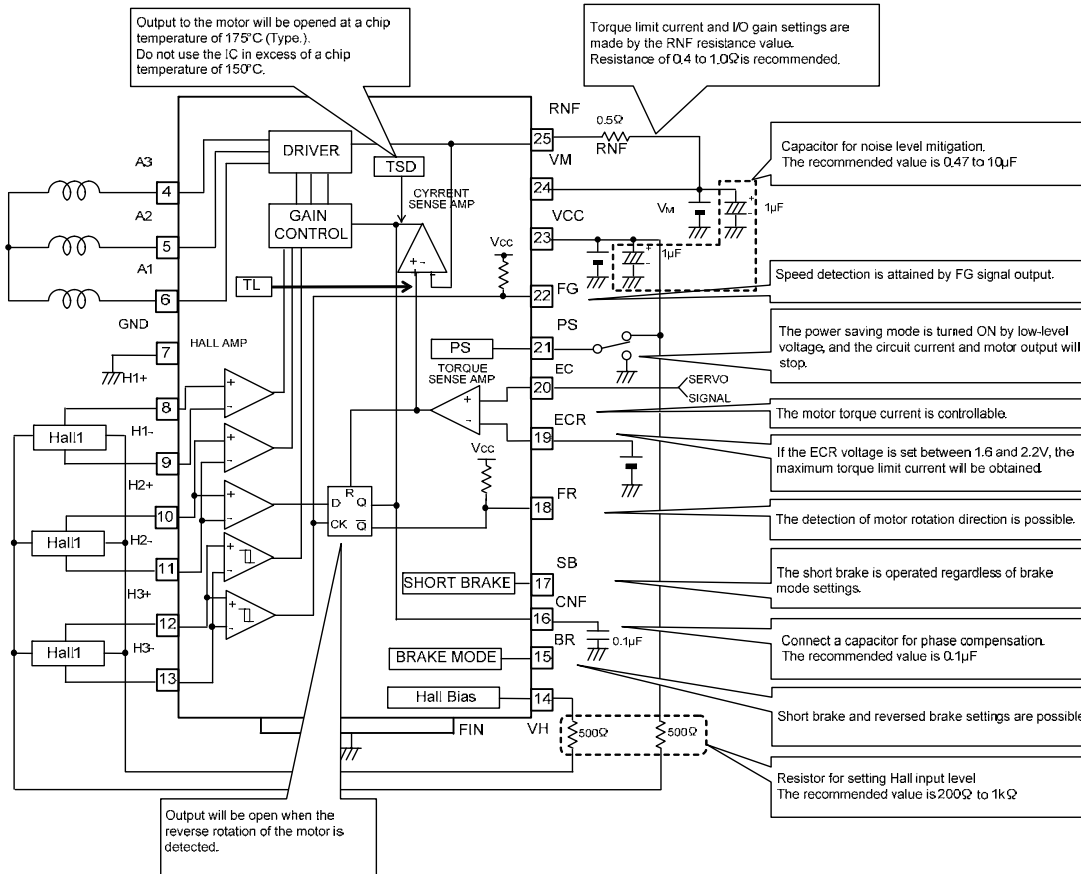

Fig.4 BA6859AFP-Y Block Diagram

BA6859AFP-Y Pin Function Table

Pin No.	Pin name	Function
1	N.C.	N.C.
2	N.C.	N.C.
3	N.C.	N.C.
4	A3	Output pin
5	A2	Output pin
6	A1	Output pin
7	GND	GND pin
8	H1+	Hall signal input pin
9	H1-	Hall signal input pin
10	H2+	Hall signal input pin
11	H2-	Hall signal input pin
12	H3+	Hall signal input pin
13	H3-	Hall signal input pin
14	VH	Hall bias input pin
15	BR	Brake mode selection pin
16	CNF	Capacitor connection pin for phase compensation
17	SB	Short brake pin
18	FR	Rotation detection pin
19	ECR	Output voltage control reference pin
20	EC	Output voltage control pin
21	PS	Power-saving pin
22	FG	FG signal output pin
23	VCC	Power supply pin
24	VM	Motor power supply pin
25	RNF	Resistance connection pin for output current detection
FIN	FIN	GND

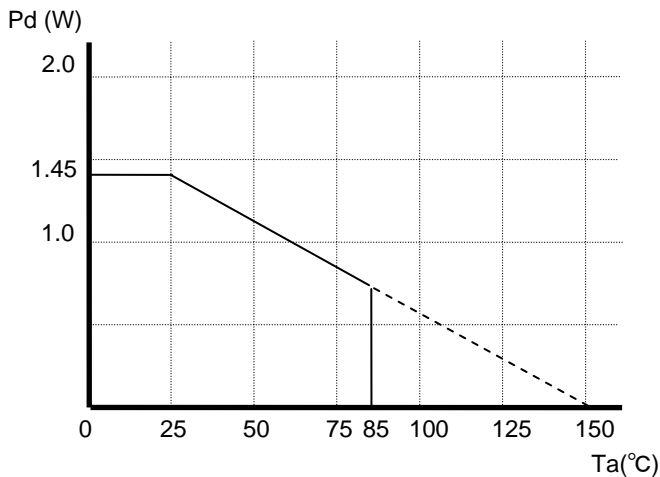

Fig.5 Power Dissipation Reduction (BA6859AFP-Y)

\* Reduced by 11.6 mW/°C over 25°C, when mounted on a glass epoxy board (70 mm x 70 mm x 1.6 mm).

2)BA6664FM

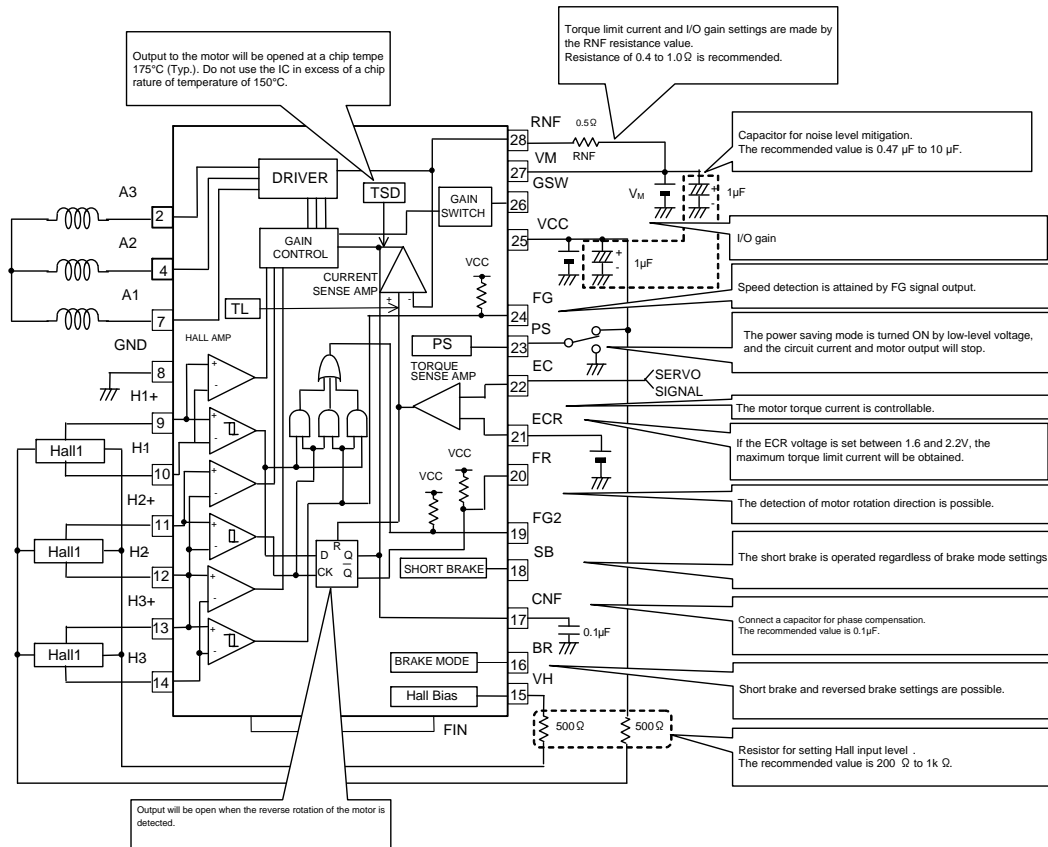

Fig.6 BA6664FM Block Diagram

BA6664FM Pin Function Table

Pin No.	Pin name	Function
1	N.C.	N.C.
2	A3	Output pin
3	N.C.	N.C.
4	A2	Output pin
5	N.C.	N.C.
6	N.C.	N.C.
7	A1	Output pin
8	GND	GND pin
9	H1+	Hall signal input pin
10	H1-	Hall signal input pin
11	H2+	Hall signal input pin
12	H2-	Hall signal input pin
13	H3+	Hall signal input pin
14	H3-	Hall bias input pin
15	VH	Hall bias input pin
16	BR	Brake mode pin
17	CNF	Capacitor connection pin for phase compensation
18	SB	Short brake pin
19	FG2	FG 3-phase component output pin
20	FR	Rotation detection pin
21	ECR	Output voltage control reference pin
22	EC	Output voltage control pin
23	PS	Power-saving pin
24	FG	FG signal output pin
25	VCC	Power supply pin
26	GSW	Gain switching pin
27	VM	Motor power supply pin
28	RNF	Resistance connection pin for output current detection
FIN	FIN	GND

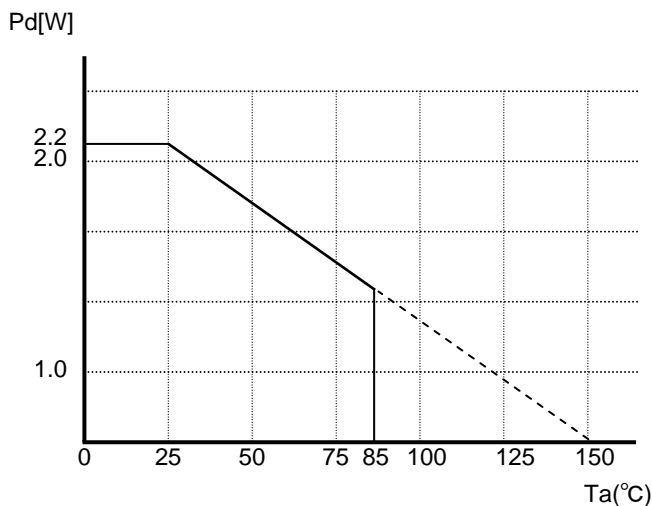
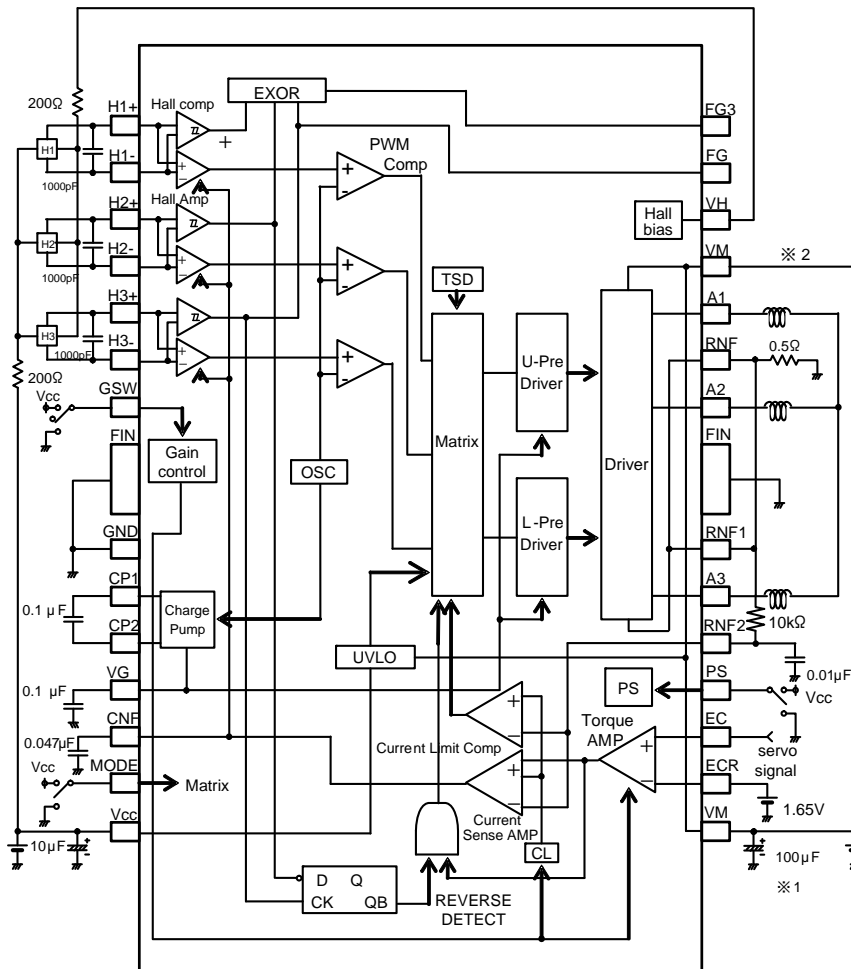

Fig.7 Power Dissipation Reduction (BA6664FM, BD6671FM)

\*Reduced by 11.6 mW/°C over 25°C, when mounted on a glass epoxy board (70 mm x 70 mm x 1.6 mm).

3)BD6671FM



※ 1 Set capacitor between VM and GND, close as possible to the IC.  
 ※ 2 To prevent from concentration of current routes, make the wiring impedance values from the power supply equal as possible.

Fig.8 BD6671FM Block Diagram

BD6671FM Pin Function

Pin No	Pin name	Function	Pin No	Pin name	Function
1	H1+	Hall signal input pin	15	VM	Motor power supply pin
2	H1-	Hall signal input pin	16	ECR	Output voltage control reference pin
3	H2+	Hall signal input pin	17	EC	Output voltage control pin
4	H2-	Hall signal input pin	18	PS	Power-saving pin
5	H3+	Hall signal input pin	19	RNF2	Resistance connection pin for output current detection
6	H3-	Hall signal input pin	20	A3	Output pin
7	GSW	Gain switching pin	21	RNF1	Resistance connection pin for output current detection
8	GND	GND	22	A2	Output pin
9	CP1	Charge pump capacity connection pin 1	23	RNF1	Resistance connection for output current
10	CP2	Charge pump capacity connection pin 2	24	A1	Output pin
11	VG	Charge pump output pin	25	VM	Motor power supply pin
12	CNF	Capacitor connection pin for phase compensation	26	VH	Hall bias pin
13	MODE	Brake mode switching pin	27	FG	FG Output pin
14	VCC	Power supply pin	28	FG3	FG3 Output pin
				FIN	GND

\*Heat radiation FIN: GND

● I/O logic

1) BA6859AFP-Y

Input conditions							Output conditions					
							Forward rotation			Reverse rotation		
Pin. No	8	9	10	11	12	13	6	5	4	6	5	4
	H1 +	H1 -	H2 +	H2 -	H3 +	H3 -	A1	A2	A3	A1	A2	A3
1	L	M	H	M	M	M	H	L	L	L	H	H
2	H	M	L	M	M	M	L	H	H	H	L	L
3	M	M	L	M	H	M	L	H	L	H	L	H
4	M	M	H	M	L	M	H	L	H	L	H	L
5	H	M	M	M	L	M	L	L	H	H	H	L
6	L	M	M	M	H	M	H	H	L	L	L	H

Input voltage  
Hi=2.6V  
Mid=2.5V  
Low=2.4V

Note: Forward rotation EC<ECR  
Reverse rotation EC>ECR

2) BA6664FM

Input conditions							Output conditions					
							Forward rotation			Reverse rotation		
Pin. No	9	10	11	12	13	14	7	4	2	7	4	2
	H1 +	H1 -	H2 +	H2 -	H3 +	H3 -	A1	A2	A3	A1	A2	A3
1	L	M	H	M	M	M	H	L	L	L	H	H
2	H	M	L	M	M	M	L	H	H	H	L	L
3	M	M	L	M	H	M	L	H	L	H	L	H
4	M	M	H	M	L	M	H	L	H	L	H	L
5	H	M	M	M	L	M	L	L	H	H	H	L
6	L	M	M	M	H	M	H	H	L	L	L	H

Input voltage  
Hi=2.6V  
Mid=2.5V  
Low=2.4V

Note: Forward rotation EC<ECR  
Reverse rotation EC>ECR

3) BD6671FM

Input conditions							Output conditions								
							Forward rotation			Reverse rotation (MODE=L)			Reverse rotation (MODE=H)		
Pin. No	1	2	3	4	5	6	24	22	20	24	22	20	24	22	20
	H1 +	H1 -	H2 +	H2 -	H3 +	H3 -	A1	A2	A3	A1	A2	A3	A1	A2	A3
1	L	M	H	M	M	M	H	L	L	L	H	H	L	L	L
2	H	M	L	M	M	M	L	H	H	H	L	L	L	L	L
3	M	M	L	M	H	M	L	H	L	H	L	H	L	L	L
4	M	M	H	M	L	M	H	L	H	L	H	L	L	L	L
5	H	M	M	M	L	M	L	L	H	H	H	L	L	L	L
6	L	M	M	M	H	M	H	H	L	L	L	H	L	L	L

Input voltage  
Hi=2.6V  
Mid=2.5V  
Low=2.4V

Note: Forward rotation EC<ECR  
Reverse rotation EC>ECR



● I/O Timing Chart

1) BA6859AFP-Y, BA6664FM

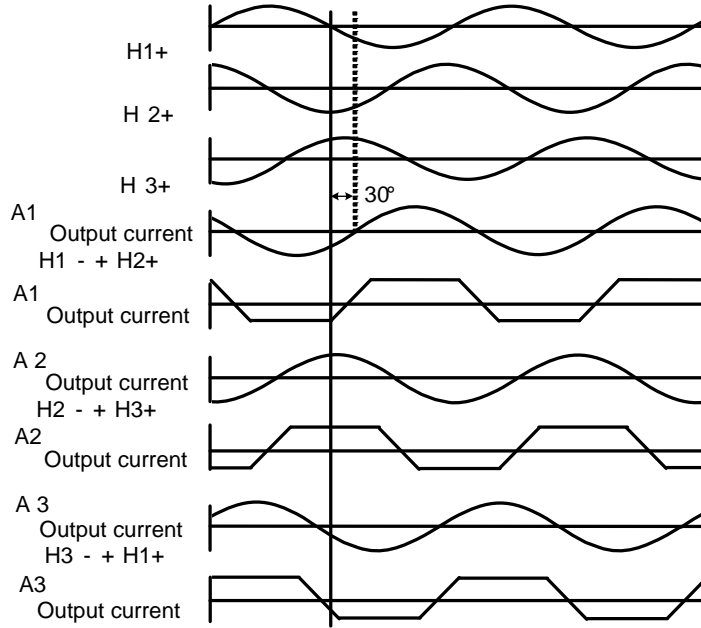

Fig. 9

2) BD6671FM

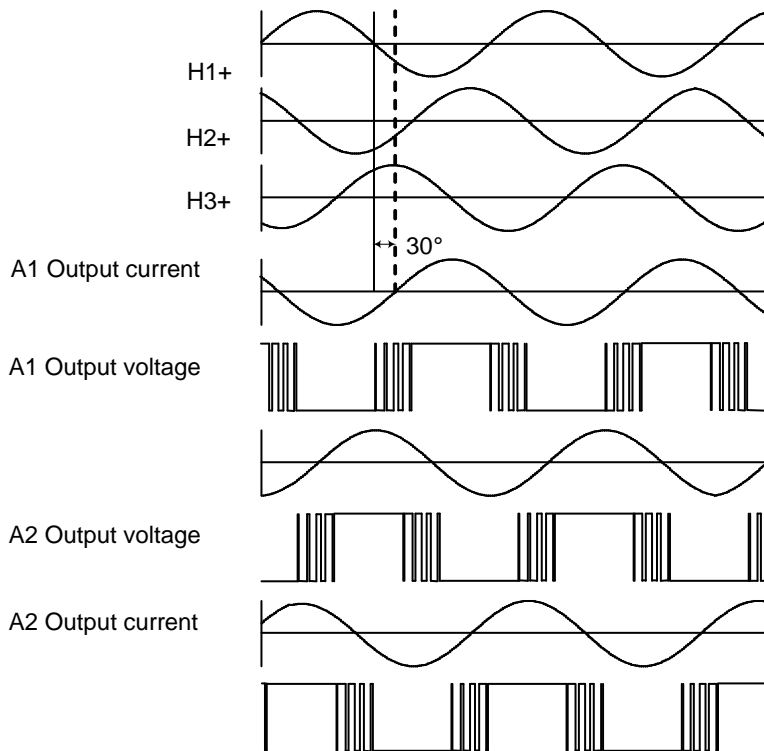
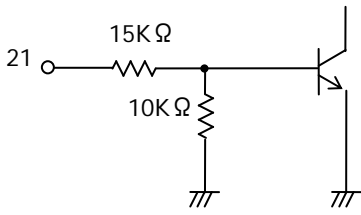

Fig. 10

● I/O Circuit

1) BA6859AFP-Y

(1) Power saving (pin 21)



(2) Torque command input (pin 19, pin 20)

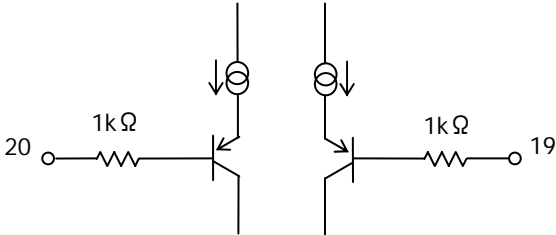

(3) Coil output (A1: pin 6, A2: pin 5, A3: pin 4)

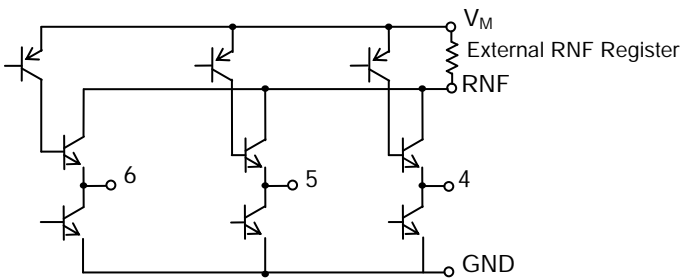

(4) Hall input (H1+ : 8 pin, H1- : 9 pin, H2+ : 10 pin, H2- : 11 pin, H3+ : 12 pin, H3- : 13 pin)

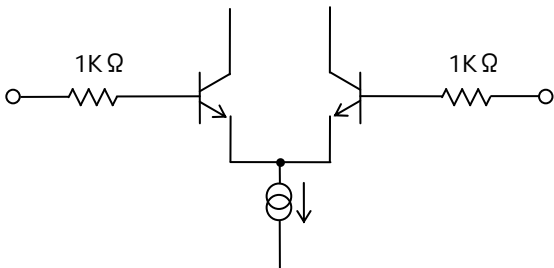

(5) Hall bias (14 pin)

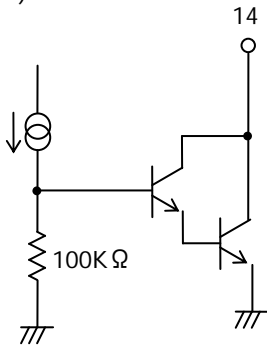

(6) FG output (pin 22)

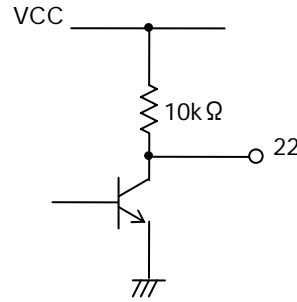

(7) FR output (pin 18)

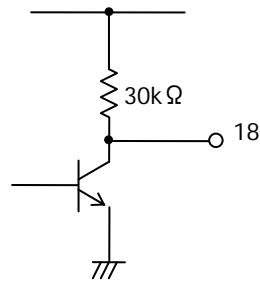

(8) Short brake (17 pin)

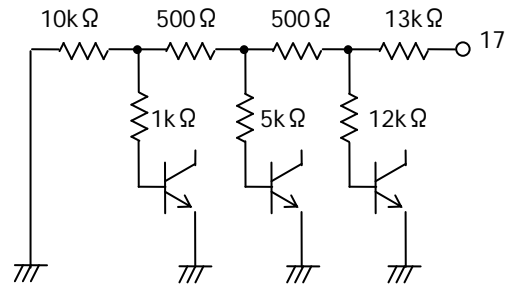

(9) Brake mode (15 pin)

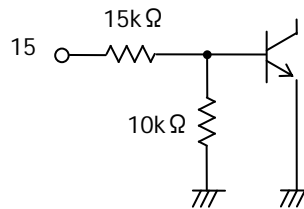

2) BA6664FM

(1) Power saving (23 pin)

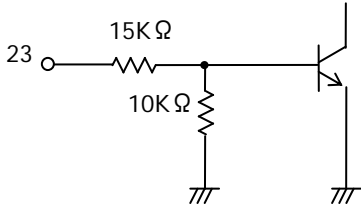

(2) Torque command input (21 pin, 22 pin)

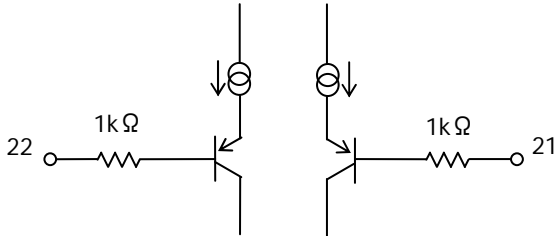

(3) Coil output (A1 : 7 pin, A2 : 4 pin, A3 : 2 pin)

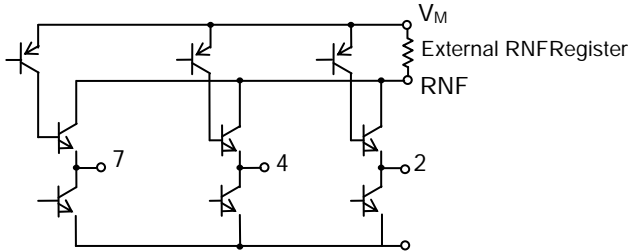

(4) Hall input (H1+ : 9 pin, H1- : 10 pin, H2+ : 11 pin, H2- : 12 pin, H3+ : 13 pin, H3- : 14 pin)

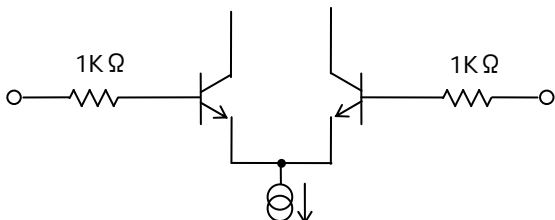

(5) Hall bias (15 pin)

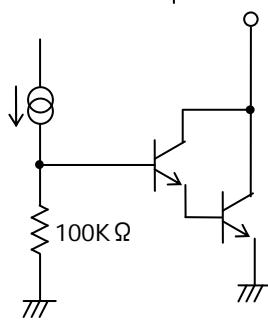

(6) FG output (24 pin)

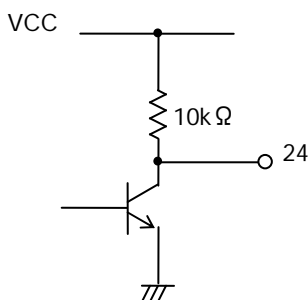

(7) FG output (19 pin)

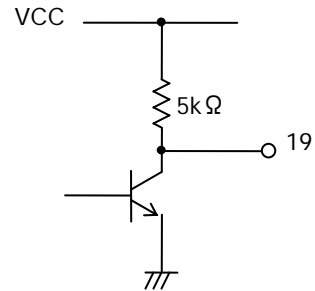

(8) FR output (20 pin)

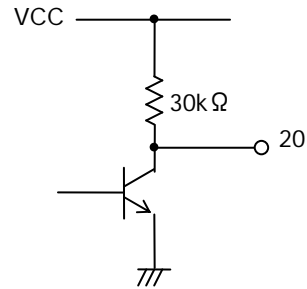

(9) Short Brake mode (18 pin)

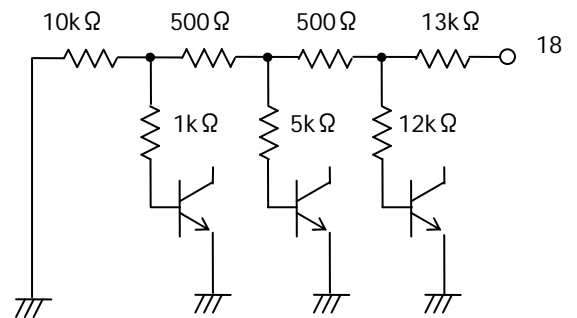

(10) Brake mode (16 pin)

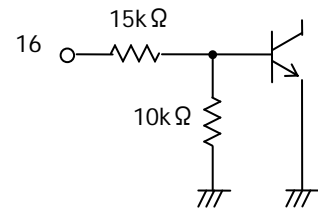

(11) Gain switch (26 pin)

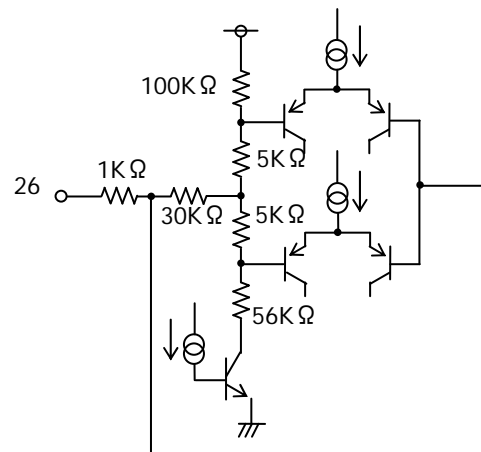

3)BD6671FM

(1) Hall input (H1 : 1 pin, H1- : 2 pin, H2+ : 3 pin, H2- : 4 pin, H3+ : 5 pin, H3- : 6 pin)

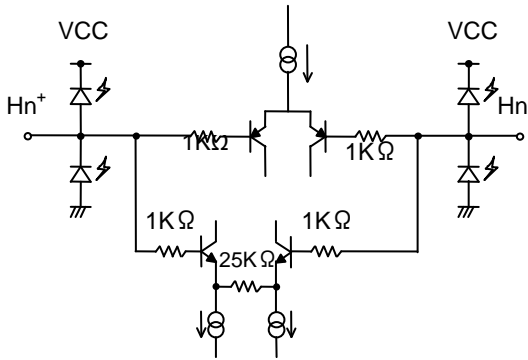

(2) Gain switch (7pin)

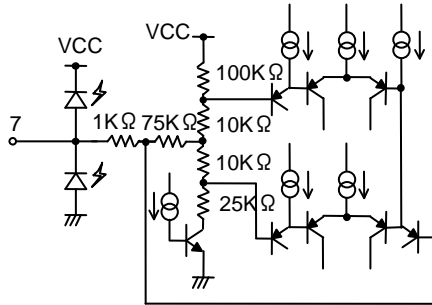

(3)CP1 output (9pin)

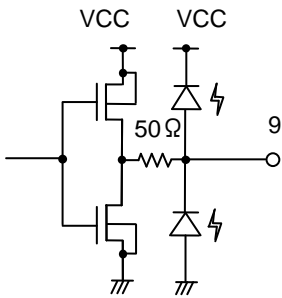

(4) CP2 / VG output (CP2 : 10 pin, VG : 11 pin)

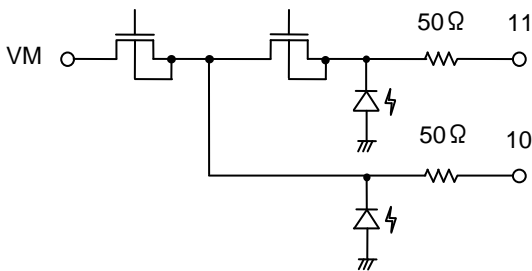

(5) CNF pin (12 pin)

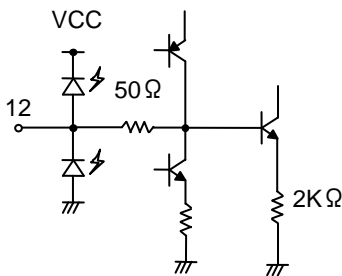

(11) Hall bias (26 pin)

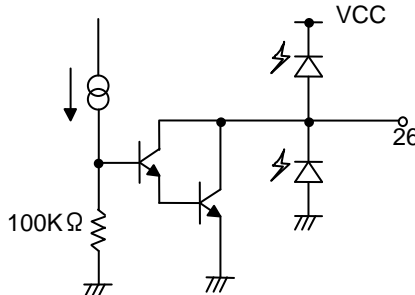

(12) FG / FG3 output (FG : 27 pin, FG3 : 28 pin)

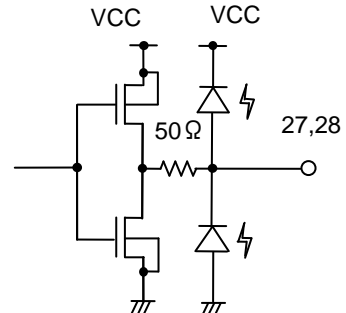

(6) Brake mode selection pin (13 pin)

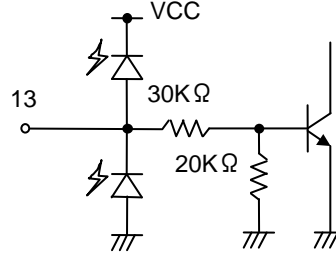

(7) Torque amp (ECR : 16 pin, EC : 17 pin)

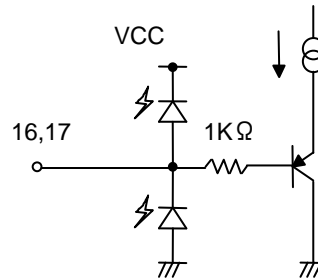

(8) Power saving (18 pin)

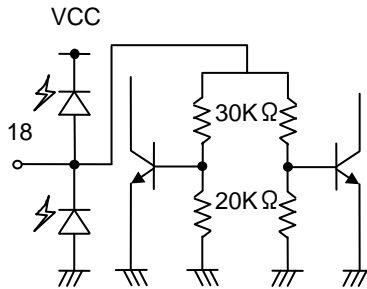

(9)RNF2(19 pin)

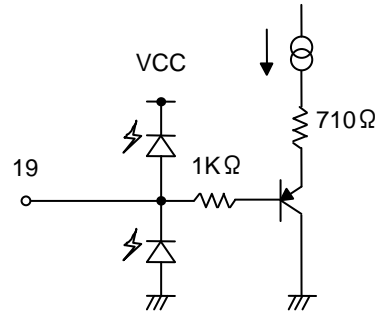

(10) Output pin (A1 : 24 pin, A2 : 22 pin, A3 : 20 pin)

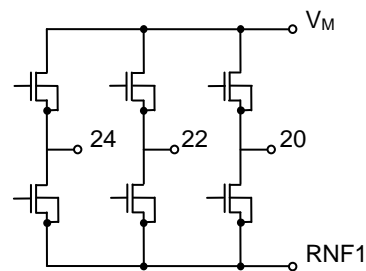

●Operation Explanation  
●Torque Command

	Rotation direction
EC<ECR	Forward
EC>ECR	Reverse*

\*Stops after detecting reverse rotation

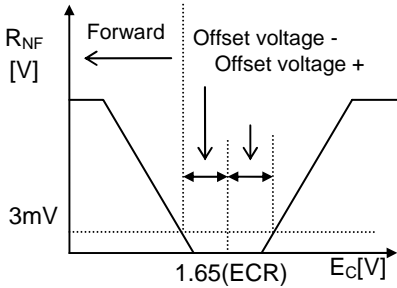

Fig.11

The I/O gain  $G_{EC}$  from the EC pin to the RNF pin (output current) is determined by the RNF detection resistor.

- ①(BA6859AFP-Y)  
 $G_{EC} = 0.35/RNF [A/V] \dots\dots(1)$
- ②(BA6664FM)  
 $G_{ECL} = 0.325/RNF [A/V] (GSW=L)$   
 $G_{ECM} = 0.60/RNF [A/V] (GSW=OPEN)$   
 $G_{ECH} = 1.4/RNF [A/V] (GSW=H)$
- ③(BD6671FM)  
 $G_{ECL} = 0.175/RNF [A/V] (GSW=L)$   
 $G_{ECM} = 0.35/RNF [A/V] (GSW=M)$   
 $G_{ECH} = 0.70/RNF [A/V] (GSW=H)$

④The following torque limit current  $I_{TL}$  is obtained (BA6859AFP-Y, BA6664FM)

$I_{TL} = 0.35/RNF [A] \dots\dots\dots(2)$

- ⑤(BD6671FM)  
 $I_{TLL} = 0.2/RNF [A] (GSW=L)$   
 $I_{TLM} = 0.4/RNF [A] (GSW=M)$   
 $I_{TLH} = 0.6/RNF [A] (GSW=H)$

The value will become smaller than the computed value due to the wiring capacity and other factors, if the RNF resistance is 0.5Ω or below.

●Set-up of Motor Rotation Direction and Voltage Range of Torque Control Reference Terminal.

The motor rotation direction determined by the torque control terminal voltage EC and the torque control reference terminal voltage ECR

Torque control input voltage	Rotation direction
EC<ECR	Forward torque
EC>ECR	Reverse torque

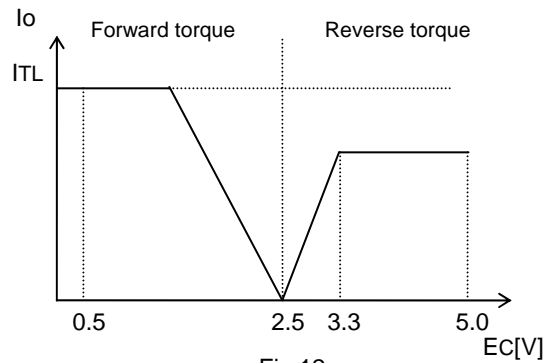

Fig.12

The relation between the input gain and torque limit current expressed as (1) and (2) discussed previously is only valid when EC and ECR are within a range from 0.5V to 3.3V. Depending on how the torque control reference terminal voltage, ECR is specified, there may be a case when the output current for the motor does not go up to the torque limit value. Please be aware of this voltage range when specifying the ECR voltage.

For BA6859AFP-Y, BA6664FM and BD6671FM, 1.6V~2.2V is recommended.

If above conditions are understood, the voltage input range to the EC and ECR terminals can be from 0V to VCC.

●Power Saving

The input circuit specified in I/O circuit 1) BA6859AFP-Y (1) is used for power saving input. The power saving pin has a temperature characteristic of approximately -5 mV/°C and also the built-in resistors has a dispersion of 30%. Keep the input voltage range in mind.

●Reverse Rotation Detection Function

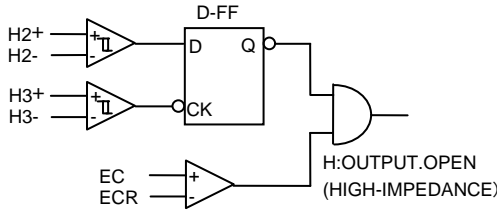

Fig.13

Actual motor rotation at reverse detection

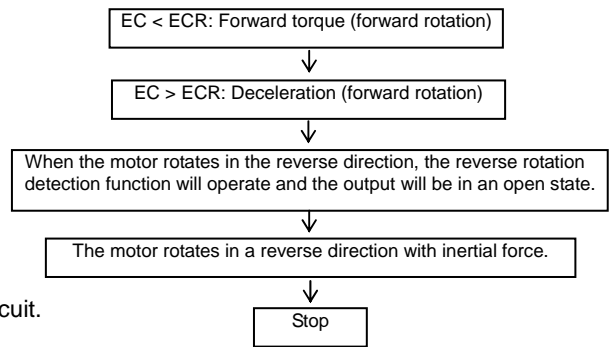

Fig. 13 shows the construction of the reverse rotation detection circuit.

- Forward rotation (EC<ECR)

Fig. 9 shows the phase relation of the H2+ and H3+ Hall input signals, in which case the reverse rotation detection circuit will not work.

- Reverse rotation (EC>ECR)

The phase relation of the H2+ and H3+ signals are opposite to that when the motor is rotating in the forward direction. Therefore, the reverse rotation detection circuit operates, and the output is turned off and open.

●FR Signal Output (BA6859AFP-Y, BA6664FM)

FR output signal pin outputs the FR signal of low(L) or high(H) after detecting the motor rotation direction.

Motor rotation direction	FR signal output
Forward	“H”
Reverse	“L”

●Brake Mode Change (BA6664FM, BD6671FM)

By applying high-level voltage to the BR pin, the brake mode for the following condition can be changed: EC > ECR.

		EC<ECR	EC>ECR
BR	L	Forward rotation	Reverse rotation brake
	H	Forward rotation	Short brake

When the BR pin is set to high level and used in short-brake mode, open the SB pin.

The BR pin has a temperature characteristics of approximately -5 mV/°C. Use the BR pin within the permissible input range.

●Short Brake (BA6859AFP-Y, BA6664FM)

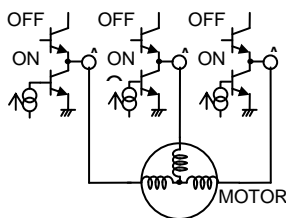

Fig.14

When the short-brake pin is set to high level, as shown in Fig.18, the output transistor (3-phase) on the high side will be turned off and the output transistor (3-phase) on the low side will be turned on. The short brake pin has a temperature characteristic of approximately -5 mV/°C. Keep the input voltage range (see Fig12) in mind.

●Hall Input

The Hall element allows both serial and parallel connections.

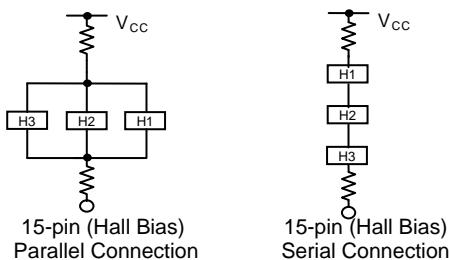

Fig.15

Set the Hall input voltage between 1.0 and 4.0 V. Compute the resistance between the VH and VCC pins in consideration of the flowing current of the Hall device.

### ●FG Signal Output / FG2 Signal Output

The FG signal output/FG2 signal output terminals are for detecting the motor rotation speed. The output frequency of FG2 signal is three times higher than the FG frequency signal output. So, it is suitable for the slow speed rotation detection. However, due to the Hall device variation and other reasons, the duty cycle may not reach 50% in some instances.

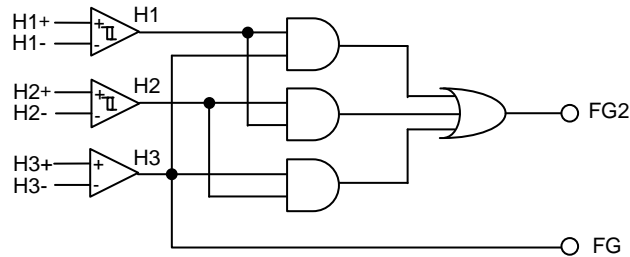

Fig. 16

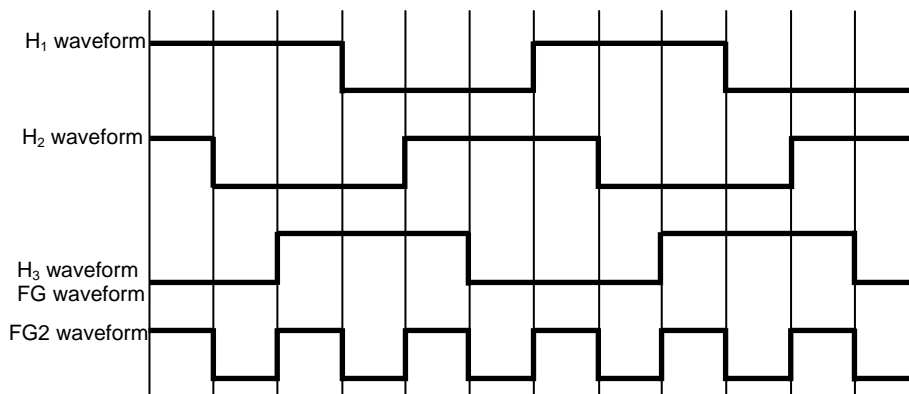

Fig. 17

### ●Notes for use

#### (1) Absolute maximum ratings

This product is subject to a strict quality management regime during its manufacture. However, damage may result if absolute maximum ratings such as applied voltage and operating temperature range are exceeded. Assumptions should not be made regarding the state of the IC (short mode or open mode) when such damage is suffered. A physical safety measure such as a fuse should be implemented when use of the IC in a special mode where the absolute maximum ratings may be exceeded is anticipated.

#### (2) Connecting the power supply connector backward

Connecting the power supply connector backwards may result in damage to the IC. Insert external diodes between the power supply and the IC's power supply pins as well as the motor coil to protect against damage from backward connections.

#### (3) Power supply lines

As return of current regenerated by back electromotive force of motor happens, take steps such as putting capacitor between power source and GND as an electric pathway for the regenerated current. Be sure that there is no problem with each property such as emptied capacity at lower temperature regarding electrolytic capacitor to decide capacity value. If the connected power supply does not have sufficient current absorption capacity, regenerative current will cause the voltage on the power supply line to rise, which combined with the product and its peripheral circuitry may exceed the absolute maximum ratings. It is recommended to implement a physical safety measure such as the insertion of a voltage clamp diode between the power supply and GND pins.

#### (4) GND potential

Ensure a minimum GND pin potential in all operating conditions.

#### (5) Setting of heat

Take the power dissipation (Pd) into account for practical application and make thermal design with sufficiently margined.

#### (6) Pin short and mistake fitting

Use caution when orienting and positioning the IC for mounting on printed circuit boards. Improper mounting may result in damage to the IC. Shorts between output pins or between output pins and the power supply and GND pins caused by the presence of a foreign object may result in damage to the IC.

#### (7) Actions in strong magnetic field

Use caution when using the IC in the presence of a strong magnetic field as doing so may cause the IC to malfunction.

(8) ASO

When using the IC, set the output transistor so that it does not exceed absolute maximum ratings or ASO.

(9) Thermal shutdown circuit (TSD)

This IC incorporates a TSD circuit. If the chip becomes the following temperature, coil output to the motor will be open. The TSD circuit is designed only to shut the IC off to prevent runaway thermal operation. It is not designed to protect the IC or guarantee its operation. Do not continue to use the IC after operating this circuit or use the IC in an environment where the operation of the TSD circuit is assumed.

	TSD ON temperature [°C] (typ.)	Hysteresis temperature [°C] (typ.)
BA6859AFP-Y	175	25
BA6664FM	175	15
BD6671FM	170	25

(10) Regarding input pin of the IC

This monolithic IC contains P+ isolation and P substrate layers between adjacent elements in order to keep them isolated. P/N junctions are formed at the intersection of these P layers with the N layers of other elements to create a variety of parasitic elements.

For example, when the resistors and transistors are connected to the pins as shown in Fig. 18,

- The P/N junction functions as a parasitic diode when GND > (Pin A) for the resistor or GND > (Pin B) for the transistor (NPN).
- Similarly, when GND > (Pin B) for the transistor (NPN), the parasitic diode described above combines with the N layer of other adjacent elements to operate as a parasitic NPN transistor.

The formation of parasitic elements as a result of the relationships of the potentials of different pins is an inevitable result of the IC's architecture. The operation of parasitic elements can cause interference with circuit operation as well as IC malfunction and damage. For these reasons, it is necessary to use caution so that the IC is not used in a way that will trigger the operation of parasitic elements, such as by the application of voltages lower than the GND (P substrate) voltage to input pins.

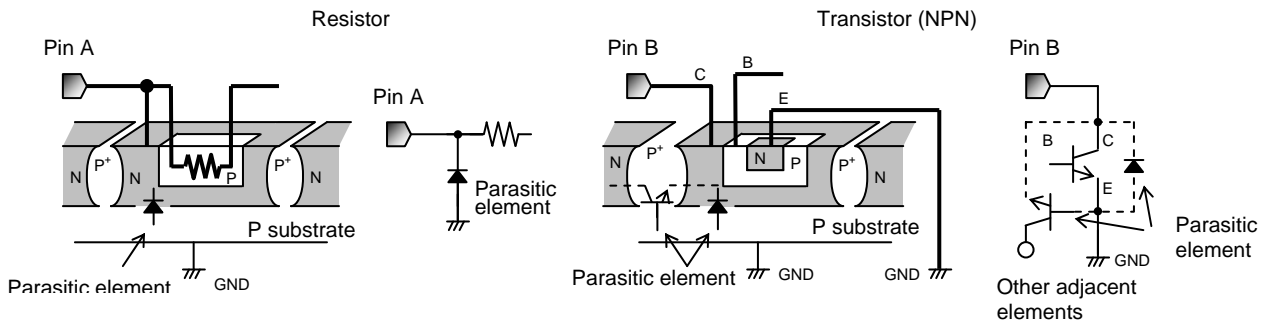

Fig.18 Example of IC structure

(11) Testing on application boards

When testing the IC on an application board, connecting a capacitor to a pin with low impedance subjects the IC to stress. Always discharge capacitors after each process or step. Ground the IC during assembly steps as an antistatic measure, and use similar caution when transporting or storing the IC. Always turn the IC's power supply off before connecting it to or removing it from a jig or fixture during the inspection process.

(12) Ground Wiring Pattern

When using both small signal and large current GND patterns, it is recommended to isolate the two ground patterns, placing a single ground point at the application's reference point so that the pattern wiring resistance and voltage variations caused by large currents do not cause variations in the small signal ground voltage. Be careful not to change the GND wiring pattern of any external parts, either.



●Ordering part number

B	A	6	6	6	4	F	M	-	E	2	
Part No. BA  BD		Part No. 6859A 6664 6671				Package FP-Y : HSOP25 FM : HSOP-M28			Packaging and forming specification E2: Embossed tape and reel		

HSOP25

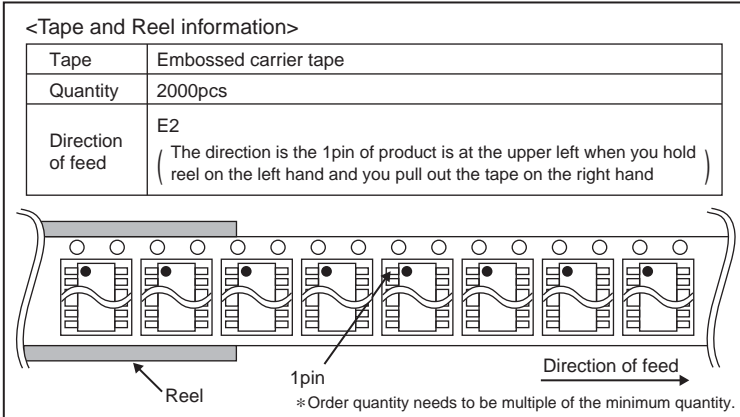
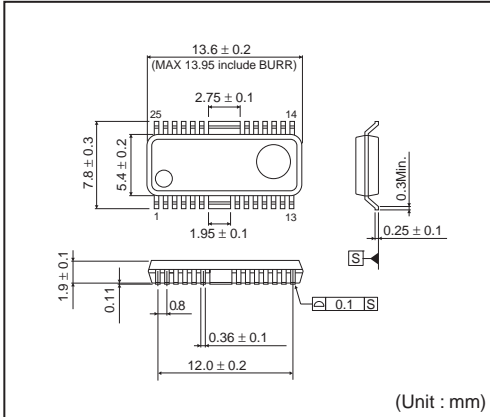

HSOP-M28

