

78K0/KB2

8-Bit Single-Chip Microcontrollers

μPD78F0500	μPD78F0500(A)
μPD78F0501	μPD78F0501(A)
μPD78F0502	μPD78F0502(A)
μPD78F0503	μPD78F0503(A)
μPD78F0503D	

The μ PD78F0503D has an on-chip debug function.

Do not use this product for mass production because its reliability cannot be guaranteed after the on-chip debug function has been used, due to issues with respect to the number of times the flash memory can be rewritten. NEC Electronics does not accept complaints concerning this product.

[MEMO]

NOTES FOR CMOS DEVICES

① VOLTAGE APPLICATION WAVEFORM AT INPUT PIN

Waveform distortion due to input noise or a reflected wave may cause malfunction. If the input of the CMOS device stays in the area between V_{IL} (MAX) and V_{IH} (MIN) due to noise, etc., the device may malfunction. Take care to prevent chattering noise from entering the device when the input level is fixed, and also in the transition period when the input level passes through the area between V_{IL} (MAX) and V_{IH} (MIN).

② HANDLING OF UNUSED INPUT PINS

Unconnected CMOS device inputs can be cause of malfunction. If an input pin is unconnected, it is possible that an internal input level may be generated due to noise, etc., causing malfunction. CMOS devices behave differently than Bipolar or NMOS devices. Input levels of CMOS devices must be fixed high or low by using pull-up or pull-down circuitry. Each unused pin should be connected to V_{DD} or GND via a resistor if there is a possibility that it will be an output pin. All handling related to unused pins must be judged separately for each device and according to related specifications governing the device.

③ PRECAUTION AGAINST ESD

A strong electric field, when exposed to a MOS device, can cause destruction of the gate oxide and ultimately degrade the device operation. Steps must be taken to stop generation of static electricity as much as possible, and quickly dissipate it when it has occurred. Environmental control must be adequate. When it is dry, a humidifier should be used. It is recommended to avoid using insulators that easily build up static electricity. Semiconductor devices must be stored and transported in an anti-static container, static shielding bag or conductive material. All test and measurement tools including work benches and floors should be grounded. The operator should be grounded using a wrist strap. Semiconductor devices must not be touched with bare hands. Similar precautions need to be taken for PW boards with mounted semiconductor devices.

④ STATUS BEFORE INITIALIZATION

Power-on does not necessarily define the initial status of a MOS device. Immediately after the power source is turned ON, devices with reset functions have not yet been initialized. Hence, power-on does not guarantee output pin levels, I/O settings or contents of registers. A device is not initialized until the reset signal is received. A reset operation must be executed immediately after power-on for devices with reset functions.

⑤ POWER ON/OFF SEQUENCE

In the case of a device that uses different power supplies for the internal operation and external interface, as a rule, switch on the external power supply after switching on the internal power supply. When switching the power supply off, as a rule, switch off the external power supply and then the internal power supply. Use of the reverse power on/off sequences may result in the application of an overvoltage to the internal elements of the device, causing malfunction and degradation of internal elements due to the passage of an abnormal current.

The correct power on/off sequence must be judged separately for each device and according to related specifications governing the device.

⑥ INPUT OF SIGNAL DURING POWER OFF STATE

Do not input signals or an I/O pull-up power supply while the device is not powered. The current injection that results from input of such a signal or I/O pull-up power supply may cause malfunction and the abnormal current that passes in the device at this time may cause degradation of internal elements. Input of signals during the power off state must be judged separately for each device and according to related specifications governing the device.

EEPROM is a trademark of NEC Electronics Corporation.

Windows and Windows NT are registered trademarks or trademarks of Microsoft Corporation in the United States and/or other countries.

PC/AT is a trademark of International Business Machines Corporation.

HP9000 series 700 and HP-UX are trademarks of Hewlett-Packard Company.

SPARCstation is a trademark of SPARC International, Inc.

Solaris and SunOS are trademarks of Sun Microsystems, Inc.

SuperFlash is a registered trademark of Silicon Storage Technology, Inc. in several countries including the United States and Japan.

Caution: This product uses SuperFlash® technology licensed from Silicon Storage Technology, Inc.

• **The information in this document is current as of April, 2006. The information is subject to change without notice. For actual design-in, refer to the latest publications of NEC Electronics data sheets or data books, etc., for the most up-to-date specifications of NEC Electronics products. Not all products and/or types are available in every country. Please check with an NEC Electronics sales representative for availability and additional information.**

• No part of this document may be copied or reproduced in any form or by any means without the prior written consent of NEC Electronics. NEC Electronics assumes no responsibility for any errors that may appear in this document.

• NEC Electronics does not assume any liability for infringement of patents, copyrights or other intellectual property rights of third parties by or arising from the use of NEC Electronics products listed in this document or any other liability arising from the use of such products. No license, express, implied or otherwise, is granted under any patents, copyrights or other intellectual property rights of NEC Electronics or others.

• Descriptions of circuits, software and other related information in this document are provided for illustrative purposes in semiconductor product operation and application examples. The incorporation of these circuits, software and information in the design of a customer's equipment shall be done under the full responsibility of the customer. NEC Electronics assumes no responsibility for any losses incurred by customers or third parties arising from the use of these circuits, software and information.

• While NEC Electronics endeavors to enhance the quality, reliability and safety of NEC Electronics products, customers agree and acknowledge that the possibility of defects thereof cannot be eliminated entirely. To minimize risks of damage to property or injury (including death) to persons arising from defects in NEC Electronics products, customers must incorporate sufficient safety measures in their design, such as redundancy, fire-containment and anti-failure features.

• NEC Electronics products are classified into the following three quality grades: "Standard", "Special" and "Specific".

The "Specific" quality grade applies only to NEC Electronics products developed based on a customer-designated "quality assurance program" for a specific application. The recommended applications of an NEC Electronics product depend on its quality grade, as indicated below. Customers must check the quality grade of each NEC Electronics product before using it in a particular application.

"Standard": Computers, office equipment, communications equipment, test and measurement equipment, audio and visual equipment, home electronic appliances, machine tools, personal electronic equipment and industrial robots.

"Special": Transportation equipment (automobiles, trains, ships, etc.), traffic control systems, anti-disaster systems, anti-crime systems, safety equipment and medical equipment (not specifically designed for life support).

"Specific": Aircraft, aerospace equipment, submersible repeaters, nuclear reactor control systems, life support systems and medical equipment for life support, etc.

The quality grade of NEC Electronics products is "Standard" unless otherwise expressly specified in NEC Electronics data sheets or data books, etc. If customers wish to use NEC Electronics products in applications not intended by NEC Electronics, they must contact an NEC Electronics sales representative in advance to determine NEC Electronics' willingness to support a given application.

(Note)

(1) "NEC Electronics" as used in this statement means NEC Electronics Corporation and also includes its majority-owned subsidiaries.

(2) "NEC Electronics products" means any product developed or manufactured by or for NEC Electronics (as defined above).

INTRODUCTION

Readers

This manual is intended for user engineers who wish to understand the functions of the 78K0/KB2 and design and develop application systems and programs for these devices. The target products are as follows.

<R>

78K0/KB2: μ PD78F0500, 78F0501, 78F0502, 78F0503, 78F0503D,
 μ PD78F0500(A), 78F0501(A), 78F0502(A), 78F0503(A)

Purpose

This manual is intended to give users an understanding of the functions described in the **Organization** below.

Organization

The 78K0/KB2 manual is separated into two parts: this manual and the instructions edition (common to the 78K/0 Series).

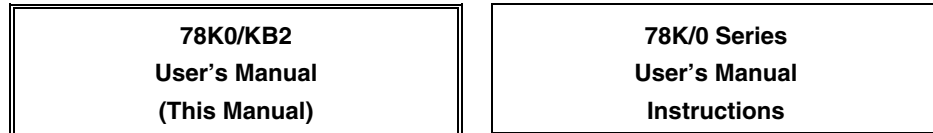

- Pin functions
- Internal block functions
- Interrupts
- Other on-chip peripheral functions
- Electrical specifications
- CPU functions
- Instruction set
- Explanation of each instruction

How to Read This Manual

It is assumed that the readers of this manual have general knowledge of electrical engineering, logic circuits, and microcontrollers.

<R>

- When using this manual as the manual for (A) grade products :
 - Only the quality grade differs between standard products and (A) grade products. Read the part number as follows.
 - μ PD78F0500 → μ PD78F0500(A)
 - μ PD78F0501 → μ PD78F0501(A)
 - μ PD78F0502 → μ PD78F0502A
 - μ PD78F0503 → μ PD78F0503(A)
- To gain a general understanding of functions:
 - Read this manual in the order of the **CONTENTS**. The mark "<R>" shows major revised points. The revised points can be easily searched by copying an "<R>" in the PDF file and specifying it in the "Find what:" field.
- How to interpret the register format:
 - For a bit number enclosed in angle brackets, the bit name is defined as a reserved word in the RA78K0, and is defined as an sfr variable using the #pragma sfr directive in the CC78K0.
- To check the details of a register when you know the register name:
 - See **APPENDIX C REGISTER INDEX**.
- To know details of the 78K/0 Series instructions:

→ Refer to the separate document **78K/0 Series Instructions User's Manual (U12326E)**.

Conventions	Data significance:	Higher digits on the left and lower digits on the right
	Active low representations:	xxx̄ (overscore over pin and signal name)
	Note:	Footnote for item marked with Note in the text
	Caution:	Information requiring particular attention
	Remark:	Supplementary information
	Numerical representations:	Binary ... xxxx or xxxxB
		Decimal ... xxxxx
	Hexadecimal ... xxxxH	

Related Documents The related documents indicated in this publication may include preliminary versions. However, preliminary versions are not marked as such.

Documents Related to Devices

	Document Name	Document No.
	78K0/KB2 User's Manual	This manual
	78K/0 Series Instructions User's Manual	U12326E
<R>	78K0/Kx2 Flash Memory Programming (Programmer) Application Note	U17739E
<R>	78K0/Kx2 Flash Memory Self Programming User's Manual ^{Note}	U17516E

Note This document is under engineering management. For details, consult an NEC Electronics sales representative.

Documents Related to Development Tools (Software) (User's Manuals)

	Document Name	Document No.	
	RA78K0 Ver. 3.80 Assembler Package	Operation	U17199E
		Language	U17198E
		Structured Assembly Language	U17197E
	CC78K0 Ver. 3.70 C Compiler	Operation	U17201E
		Language	U17200E
	SM+ System Simulator	Operation	U17246E
		External Part User Open Interface Specifications	U17247E
	ID78K0-QB Ver. 2.90 Integrated Debugger	Operation	U17437E
	PM+ Ver. 5.20		U16934E

Documents Related to Development Tools (Hardware) (User's Manuals)

	Document Name	Document No.
	QB-78K0KX2 In-Circuit Emulator	U17341E
	QB-78K0MINI On-Chip Debug Emulator	U17029E

Caution The related documents listed above are subject to change without notice. Be sure to use the latest version of each document when designing.

Documents Related to Flash Memory Programming (User's Manuals)

	Document Name	Document No.
	PG-FP4 Flash Memory Programmer	U15260E
<R>	PG-FPL3 Flash Memory Programmer	U17454E

Other Documents

	Document Name	Document No.
	SEMICONDUCTOR SELECTION GUIDE – Products and Packages –	X13769X
	Semiconductor Device Mount Manual	Note
	Quality Grades on NEC Semiconductor Devices	C11531E
	NEC Semiconductor Device Reliability/Quality Control System	C10983E
	Guide to Prevent Damage for Semiconductor Devices by Electrostatic Discharge (ESD)	C11892E

Note See the “Semiconductor Device Mount Manual” website (<http://www.necel.com/pkg/en/mount/index.html>).

Caution The related documents listed above are subject to change without notice. Be sure to use the latest version of each document when designing.

CONTENTS

CHAPTER 1 OUTLINE	16
1.1 Features	16
1.2 Applications	17
1.3 Ordering Information	18
1.4 Pin Configuration (Top View)	19
1.5 78K0/Kx2 Series Lineup	22
1.6 Block Diagram	25
1.7 Outline of Functions	26
CHAPTER 2 PIN FUNCTIONS	28
2.1 Pin Function List	28
2.2 Description of Pin Functions	31
2.2.1 P00 and P01 (port 0).....	31
2.2.2 P10 to P17 (port 1).....	31
2.2.3 P20 to P23 (port 2).....	32
2.2.4 P30 to P33 (port 3).....	32
2.2.5 P60 and P61 (port 6).....	33
2.2.6 P120 to P122 (port 12).....	34
2.2.7 AVREF	35
2.2.8 AVSS.....	35
2.2.9 RESET	35
2.2.10 REGC	35
2.2.11 VDD and EVDD.....	35
2.2.12 VSS and EVSS	35
2.2.13 FLMD0	35
2.3 Pin I/O Circuits and Recommended Connection of Unused Pins	36
CHAPTER 3 CPU ARCHITECTURE	40
3.1 Memory Space	40
3.1.1 Internal program memory space	47
3.1.2 Internal data memory space	48
3.1.3 Special function register (SFR) area	48
3.1.4 Data memory addressing.....	48
3.2 Processor Registers	53
3.2.1 Control registers.....	53
3.2.2 General-purpose registers	57
3.2.3 Special function registers (SFRs).....	58
3.3 Instruction Address Addressing	62
3.3.1 Relative addressing	62
3.3.2 Immediate addressing.....	63
3.3.3 Table indirect addressing.....	64
3.3.4 Register addressing	64
3.4 Operand Address Addressing	65

3.4.1 Implied addressing	65
3.4.2 Register addressing	66
3.4.3 Direct addressing	67
3.4.4 Short direct addressing	68
3.4.5 Special function register (SFR) addressing	69
3.4.6 Register indirect addressing	70
3.4.7 Based addressing	71
3.4.8 Based indexed addressing	72
3.4.9 Stack addressing	73
CHAPTER 4 PORT FUNCTIONS	74
4.1 Port Functions	74
4.2 Port Configuration	75
4.2.1 Port 0	76
4.2.2 Port 1	78
4.2.3 Port 2	83
4.2.4 Port 3	84
4.2.5 Port 6	87
4.2.6 Port 12	88
4.3 Registers Controlling Port Function	91
4.4 Port Function Operations	96
4.4.1 Writing to I/O port	96
4.4.2 Reading from I/O port	96
4.4.3 Operations on I/O port	96
4.5 Settings of Port Mode Register and Output Latch When Using Alternate Function	97
4.6 Cautions on 1-Bit Manipulation Instruction for Port Register n (Pn)	99
CHAPTER 5 CLOCK GENERATOR	100
5.1 Functions of Clock Generator	100
5.2 Configuration of Clock Generator	101
5.3 Registers Controlling Clock Generator	103
5.4 System Clock Oscillator	111
5.4.1 X1 oscillator	111
5.4.2 Internal high-speed oscillator	113
5.4.3 Internal low-speed oscillator	113
5.4.4 Prescaler	113
5.5 Clock Generator Operation	114
5.6 Controlling Clock	117
5.6.1 Controlling high-speed system clock	117
5.6.2 Example of controlling internal high-speed oscillation clock	120
5.6.3 Example of controlling internal low-speed oscillation clock	122
5.6.4 Clocks supplied to CPU and peripheral hardware	123
5.6.5 CPU clock status transition diagram	124
5.6.6 Condition before changing CPU clock and processing after changing CPU clock	127
5.6.7 Time required for switchover of main system clock	128
5.6.8 Conditions before clock oscillation is stopped	129
5.6.9 Peripheral hardware and source clocks	129

CHAPTER 6 16-BIT TIMER/EVENT COUNTER 00	130
6.1 Functions of 16-Bit Timer/Event Counter 00	130
6.2 Configuration of 16-Bit Timer/Event Counter 00	131
6.3 Registers Controlling 16-Bit Timer/Event Counter 00	136
6.4 Operation of 16-Bit Timer/Event Counter 00	143
6.4.1 Interval timer operation.....	143
6.4.2 Square wave output operation.....	146
6.4.3 External event counter operation.....	149
6.4.4 Operation in clear & start mode entered by TI000 pin valid edge input.....	153
6.4.5 Free-running timer operation.....	166
6.4.6 PPG output operation.....	175
6.4.7 One-shot pulse output operation.....	178
6.4.8 Pulse width measurement operation.....	183
6.5 Special Use of TM00	191
6.5.1 Rewriting CR010 during TM00 operation.....	191
6.5.2 Setting LVS00 and LVR00.....	191
6.6 Cautions for 16-Bit Timer/Event Counter 00	193
CHAPTER 7 8-BIT TIMER/EVENT COUNTERS 50 AND 51	197
7.1 Functions of 8-Bit Timer/Event Counters 50 and 51	197
7.2 Configuration of 8-Bit Timer/Event Counters 50 and 51	197
7.3 Registers Controlling 8-Bit Timer/Event Counters 50 and 51	200
7.4 Operations of 8-Bit Timer/Event Counters 50 and 51	205
7.4.1 Operation as interval timer.....	205
7.4.2 Operation as external event counter.....	207
7.4.3 Square-wave output operation.....	208
7.4.4 PWM output operation.....	209
7.5 Cautions for 8-Bit Timer/Event Counters 50 and 51	213
CHAPTER 8 8-BIT TIMERS H0 AND H1	214
8.1 Functions of 8-Bit Timers H0 and H1	214
8.2 Configuration of 8-Bit Timers H0 and H1	214
8.3 Registers Controlling 8-Bit Timers H0 and H1	218
8.4 Operation of 8-Bit Timers H0 and H1	223
8.4.1 Operation as interval timer/square-wave output.....	223
8.4.2 Operation as PWM output.....	227
8.4.3 Carrier generator operation (8-bit timer H1 only).....	233
CHAPTER 9 WATCHDOG TIMER	240
9.1 Functions of Watchdog Timer	240
9.2 Configuration of Watchdog Timer	240
9.3 Register Controlling Watchdog Timer	242
9.4 Operation of Watchdog Timer	243
9.4.1 Controlling operation of watchdog timer.....	243
9.4.2 Setting overflow time of watchdog timer.....	244
9.4.3 Setting window open period of watchdog timer.....	245

CHAPTER 10 A/D CONVERTER	247
10.1 Function of A/D Converter.....	247
10.2 Configuration of A/D Converter	248
10.3 Registers Used in A/D Converter.....	250
10.4 A/D Converter Operations	259
10.4.1 Basic operations of A/D converter.....	259
10.4.2 Input voltage and conversion results.....	261
10.4.3 A/D converter operation mode	262
10.5 How to Read A/D Converter Characteristics Table.....	264
10.6 Cautions for A/D Converter	266
CHAPTER 11 SERIAL INTERFACE UART0	270
11.1 Functions of Serial Interface UART0.....	270
11.2 Configuration of Serial Interface UART0	271
11.3 Registers Controlling Serial Interface UART0.....	274
11.4 Operation of Serial Interface UART0	279
11.4.1 Operation stop mode.....	279
11.4.2 Asynchronous serial interface (UART) mode	280
11.4.3 Dedicated baud rate generator.....	286
11.4.4 Calculation of baud rate	288
CHAPTER 12 SERIAL INTERFACE UART6	292
12.1 Functions of Serial Interface UART6.....	292
12.2 Configuration of Serial Interface UART6	296
12.3 Registers Controlling Serial Interface UART6.....	299
12.4 Operation of Serial Interface UART6	308
12.4.1 Operation stop mode.....	308
12.4.2 Asynchronous serial interface (UART) mode	309
12.4.3 Dedicated baud rate generator.....	322
12.4.4 Calculation of baud rate	324
CHAPTER 13 SERIAL INTERFACE CSI10	329
13.1 Functions of Serial Interface CSI10.....	329
13.2 Configuration of Serial Interface CSI10	330
13.3 Registers Controlling Serial Interface CSI10.....	332
13.4 Operation of Serial Interface CSI10	335
13.4.1 Operation stop mode.....	335
13.4.2 3-wire serial I/O mode	335
CHAPTER 14 SERIAL INTERFACE IIC0.....	346
14.1 Functions of Serial Interface IIC0	346
14.2 Configuration of Serial Interface IIC0.....	349
14.3 Registers to Control Serial Interface IIC0	352
14.4 I²C Bus Mode Functions	365
14.4.1 Pin configuration	365
14.5 I²C Bus Definitions and Control Methods	366

14.5.1	Start conditions	366
14.5.2	Addresses	367
14.5.3	Transfer direction specification	367
14.5.4	Acknowledge (ACK).....	368
14.5.5	Stop condition	369
14.5.6	Wait.....	370
14.5.7	Canceling wait.....	372
14.5.8	Interrupt request (INTIIC0) generation timing and wait control	372
14.5.9	Address match detection method	373
14.5.10	Error detection	373
14.5.11	Extension code	374
14.5.12	Arbitration	375
14.5.13	Wakeup function	376
14.5.14	Communication reservation	377
14.5.15	Other cautions	380
14.5.16	Communication operations	381
14.5.17	Timing of I ² C interrupt request (INTIIC0) occurrence	389
14.6	Timing Charts	410
CHAPTER 15	INTERRUPT FUNCTIONS	417
15.1	Interrupt Function Types.....	417
15.2	Interrupt Sources and Configuration	417
15.3	Registers Controlling Interrupt Functions	420
15.4	Interrupt Servicing Operations	428
15.4.1	Maskable interrupt acknowledgement.....	428
15.4.2	Software interrupt request acknowledgement.....	430
15.4.3	Multiple interrupt servicing	431
15.4.4	Interrupt request hold.....	434
CHAPTER 16	STANDBY FUNCTION.....	435
16.1	Standby Function and Configuration.....	435
16.1.1	Standby function	435
16.1.2	Registers controlling standby function	435
16.2	Standby Function Operation.....	438
16.2.1	HALT mode.....	438
16.2.2	STOP mode	442
CHAPTER 17	RESET FUNCTION	448
17.1	Register for Confirming Reset Source.....	456
CHAPTER 18	POWER-ON-CLEAR CIRCUIT	457
18.1	Functions of Power-on-Clear Circuit	457
18.2	Configuration of Power-on-Clear Circuit.....	458
18.3	Operation of Power-on-Clear Circuit.....	458
18.4	Cautions for Power-on-Clear Circuit.....	461
CHAPTER 19	LOW-VOLTAGE DETECTOR.....	463

19.1	Functions of Low-Voltage Detector.....	463
19.2	Configuration of Low-Voltage Detector	463
19.3	Registers Controlling Low-Voltage Detector.....	464
19.4	Operation of Low-Voltage Detector	467
19.4.1	When used as reset	468
19.4.2	When used as interrupt	473
19.5	Cautions for Low-Voltage Detector	478
CHAPTER 20 OPTION BYTE.....		481
20.1	Functions of Option Bytes	481
20.2	Format of Option Byte	483
CHAPTER 21 FLASH MEMORY		486
21.1	Internal Memory Size Switching Register.....	486
21.2	Writing with Flash Memory Programmer	487
21.3	Programming Environment.....	490
21.4	Communication Mode.....	490
21.5	Handling of Pins on Board	492
21.5.1	FLMD0 pin	492
21.5.2	Serial interface pins.....	492
21.5.3	RESET pin	494
21.5.4	Port pins.....	494
21.5.5	REGC pin	494
21.5.6	Other signal pins	494
21.5.7	Power supply.....	495
21.6	Programming Method	496
21.6.1	Controlling flash memory	496
21.6.2	Flash memory programming mode	496
21.6.3	Selecting communication mode	497
21.6.4	Communication commands.....	498
21.7	Security Settings	499
21.8	Processing Time for Each Command When PG-FP4 Is Used (Reference).....	501
21.9	Flash Memory Programming by Self-Programming	502
21.9.1	Boot swap function.....	508
CHAPTER 22 ON-CHIP DEBUG FUNCTION (μPD78F0503D ONLY).....		510
22.1	Connecting QB-78K0MINI to μ PD78F0503D	510
22.2	On-Chip Debug Security ID	512
CHAPTER 23 INSTRUCTION SET.....		513
23.1	Conventions Used in Operation List	513
23.1.1	Operand identifiers and specification methods.....	513
23.1.2	Description of operation column.....	514
23.1.3	Description of flag operation column	514
23.2	Operation List	515
23.3	Instructions Listed by Addressing Type.....	523

CHAPTER 24 ELECTRICAL SPECIFICATIONS (STANDARD PRODUCTS)	526
CHAPTER 25 ELECTRICAL SPECIFICATIONS ((A) GRADE PRODUCTS, TARGET)	545
CHAPTER 26 PACKAGE DRAWING	564
CHAPTER 27 RECOMMENDED SOLDERING CONDITIONS	567
CHAPTER 28 CAUTIONS FOR WAIT	568
28.1 Cautions for Wait	568
28.2 Peripheral Hardware That Generates Wait	569
APPENDIX A DEVELOPMENT TOOLS	570
A.1 Software Package	573
A.2 Language Processing Software	573
A.3 Control Software	574
A.4 Flash Memory Writing Tools	574
A.5 Debugging Tools (Hardware)	575
A.5.1 When using in-circuit emulator QB-78K0KX2	575
A.5.2 When using on-chip debug emulator QB-78K0MINI	576
A.6 Debugging Tools (Software)	576
APPENDIX B NOTES ON TARGET SYSTEM DESIGN	577
APPENDIX C REGISTER INDEX	579
C.1 Register Index (In Alphabetical Order with Respect to Register Names)	579
C.2 Register Index (In Alphabetical Order with Respect to Register Symbol)	584
APPENDIX D LIST OF CAUTIONS	589
APPENDIX E REVISION HISTORY	613
E.1 Major Revisions in This Edition	613
E.2 Revision History of Preceding Editions	619

CHAPTER 1 OUTLINE

1.1 Features

- Minimum instruction execution time can be changed from high speed (0.1 μ s: @ 20 MHz operation with high-speed system clock) to low speed (1.6 μ s: @ 20 MHz operation with high-speed system clock)
- General-purpose register: 8 bits \times 32 registers (8 bits \times 8 registers \times 4 banks)
- ROM, RAM capacities

Part Number \ Item	Program Memory (ROM)	Data Memory (Internal High-Speed RAM ^{Note})
μ PD78F0500	Flash memory ^{Note} 8 KB	512 bytes
μ PD78F0501	16 KB	768 bytes
μ PD78F0502	24 KB	1 KB
μ PD78F0503, 78F0503D	32 KB	

Note The internal flash memory, and internal high-speed RAM capacities can be changed using the internal memory size switching register (IMS) . For IMS, see **27.1 Memory Size Switching Register**.

- On-chip single-power-supply flash memory
- Self-programming (with boot swap function)
- On-chip debug function (μ PD78F0503D only)^{Note 1}
- On-chip power-on-clear (POC) circuit and low-voltage detector (LVI)
- On-chip watchdog timer (operable with the on-chip internal low-speed oscillation clock)
- I/O ports: 23 (N-ch open drain: 2)
- Timer: 6 channels
 - 16-bit timer/event counter: 1 channel
 - 8-bit timer/event counter: 2 channels
 - 8-bit timer: 2 channels
 - Watchdog timer: 1 channel
- Serial interface: 3 channels
 - UART (LIN (Local Interconnect Network)-bus supported): 1 channel
 - CSI/UART^{Note 2}: 1 channel
 - I²C: 1 channel
- 10-bit resolution A/D converter ($AV_{REF} = 2.3$ to 5.5 V): 4 channels
- Power supply voltage: $V_{DD} = 1.8$ to 5.5 V
- <R> ○ Operating ambient temperature: $T_A = -40$ to $+85^\circ\text{C}$

- Notes**
1. The μ PD78F0503D has an on-chip debug function. Do not use this product for mass production because its reliability cannot be guaranteed after the on-chip debug function has been used, from the viewpoint of the restriction on the number of times the flash memory can be rewritten. NEC Electronics does not accept any complaint about this product.
 2. Select either of the functions of these alternate-function pins.

1.2 Applications

- Automotive equipment ((A), (A1), (A2) grade products, under development)
 - System control for body electricals (power windows, keyless entry reception, etc.)
 - Sub-microcontrollers for control
- Car audio
- AV equipment, home audio
- PC peripheral equipment (keyboards, etc.)
- Household electrical appliances
 - Air conditioners
 - Microwave ovens, electric rice cookers
- Industrial equipment
 - Pumps
 - Vending machines
 - FA (Factory Automation)

1.3 Ordering Information

<R> • Flash memory version

Part Number	Package	Quality Grade
μ PD78F0500MC-5A4-A	30-pin plastic SSOP (fine pitch) (7.62 mm(300))	Standard
μ PD78F0500FC-AA3-A	36-pin plastic FLGA (4x4)	Standard
μ PD78F0501MC-5A4-A	30-pin plastic SSOP (fine pitch) (7.62 mm(300))	Standard
μ PD78F0501FC-AA3-A	36-pin plastic FLGA (4x4)	Standard
μ PD78F0502MC-5A4-A	30-pin plastic SSOP (fine pitch) (7.62 mm(300))	Standard
μ PD78F0502FC-AA3-A	36-pin plastic FLGA (4x4)	Standard
μ PD78F0503MC-5A4-A	30-pin plastic SSOP (fine pitch) (7.62 mm(300))	Standard
μ PD78F0503FC-AA3-A	36-pin plastic FLGA (4x4)	Standard
μ PD78F0503DMC-5A4-A ^{Note 1}	30-pin plastic SSOP (fine pitch) (7.62 mm(300))	Standard
μ PD78F0503DFC-AA3-A ^{Note 1}	36-pin plastic FLGA (4x4)	Standard
μ PD78F0500MC(A)-CAB-AX ^{Note 2}	30-pin plastic SSOP (fine pitch) (7.62 mm(300))	Special
μ PD78F0501MC(A)-CAB-AX ^{Note 2}	30-pin plastic SSOP (fine pitch) (7.62 mm(300))	Special
μ PD78F0502MC(A)-CAB-AX ^{Note 2}	30-pin plastic SSOP (fine pitch) (7.62 mm(300))	Special
μ PD78F0503MC(A)-CAB-AX ^{Note 2}	30-pin plastic SSOP (fine pitch) (7.62 mm(300))	Special

Notes 1. The μ PD78F0503D has on-chip debug function. Do not use these products for mass production, because its reliability cannot be guaranteed after the on-chip debug function has been used, with respect to the number of times the flash memory can be rewritten. NEC Electronics does not accept complaints about these products.

2. Under development

Remark Products with -A and -AX at the end of the part number are lead-free products.

Please refer to "Quality Grades on NEC Semiconductor Devices" (Document No. C11531E) published by NEC Corporation to know the specification of quality grade on the devices and its recommended applications.

1.4 Pin Configuration (Top View)

- 30-pin plastic SSOP (7.62 mm (300))

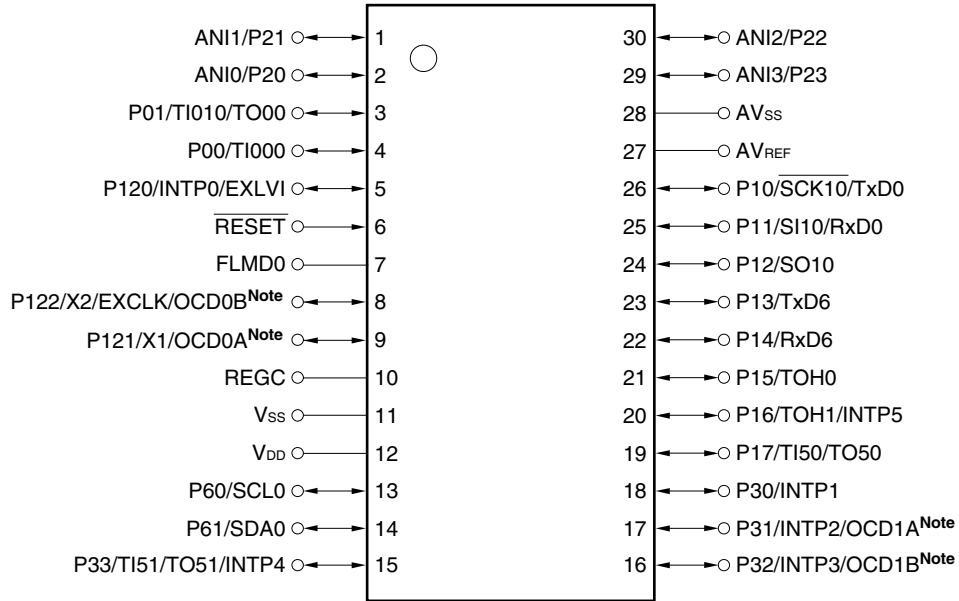

Note μ PD78F0503D (product with on-chip debug function) only

- Cautions**
1. Make AV_{SS} the same potential as V_{SS}.
 2. Connect the REGC pin to V_{SS} via a capacitor (0.47 to 1 μ F: recommended).
 3. ANI0/P20 to ANI3/P23 are set in the analog input mode after release of reset.

<R>

- 36-pin plastic FLGA (4x4)

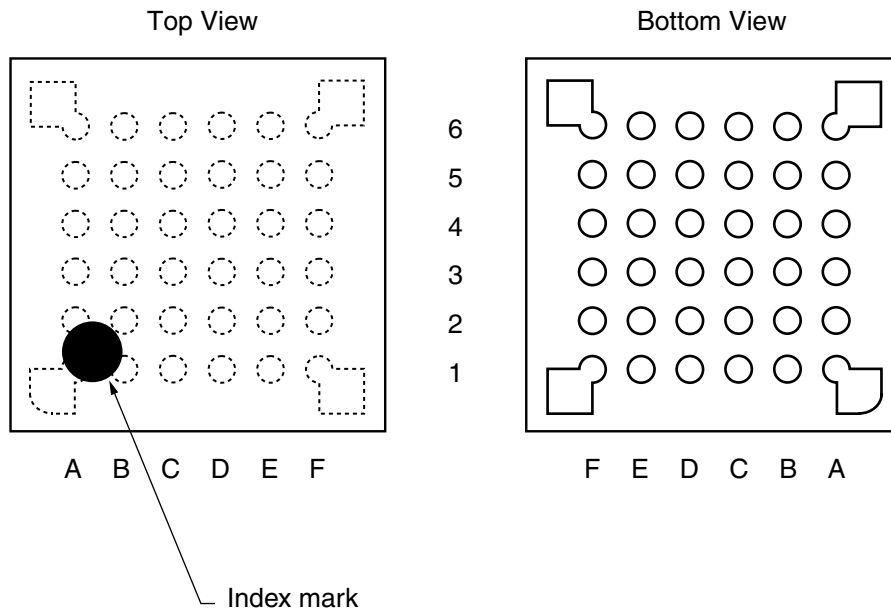

Pin No.	Pin Name	Pin No.	Pin Name	Pin No.	Pin Name
A1	NC	C1	P17/TI50/TO50	E1	AV _{REF}
A2	P32/INTP3/OCD1B ^{Note}	C2	P14/RxD6	E2	AV _{SS}
A3	P30/INTP1	C3	P13/TxD6	E3	P22/ANI2
A4	P61/SDA0	C4	P00/TI000	E4	P21/ANI1
A5	P33/TI51/TO51/INTP4	C5	V _{DD}	E5	FLMD0
A6	NC	C6	P121/X1/OCD0A ^{Note}	E6	RESET
B1	P31/INTP2/OCD1A ^{Note}	D1	P11/SI10/RxD0	F1	NC
B2	P16/TOH1/INTP5	D2	P12/SO10	F2	P23/ANI3
B3	P15/TOH0	D3	P10/SCK10/TxD0	F3	P20/ANI0
B4	P60/SCL0	D4	REGC	F4	P01/TI010/TO00
B5	EV _{DD}	D5	V _{SS}	F5	P120/INTP0/EXLVI
B6	EV _{SS}	D6	P122/X2/EXCLK/ OCD0B ^{Note}	F6	NC

Note μ PD78F0503D (product with on-chip debug function) only

- <R> **Cautions**
1. Make AV_{SS} and EV_{SS} the same potential as V_{SS}.
 2. Make EV_{DD} the same potential as V_{DD}.
 3. Connect the REGC pin to V_{SS} via a capacitor (0.47 to 1 μ F: recommended).
 4. ANI0/P20 to ANI3/P23 are set in the analog input mode after release of reset.

Pin Identification

ANI0 to ANI3:	Analog input	P60, P61:	Port 6
AV _{REF} :	Analog reference voltage	P120 to P122:	Port 12
AV _{SS} :	Analog ground	REGC	Regulator capacitance
EV _{DD} ^{Note 1} :	Power supply for port	RESET:	Reset
EV _{SS} ^{Note 1} :	Ground for port	RxD0, RxD6:	Receive data
EXCLK:	External clock input (main system clock)	SCK10:	Serial clock input/output
EXLVI:	External potential input for low-voltage detector	SCL0:	Serial clock input/output
FLMD0:	Flash programming mode	SDA0:	Serial data input/output
INTP0 to INTP5:	External interrupt input	SI10:	Serial data input
NC:	Non-connection	SO10:	Serial data output
OCD0A ^{Note 2} ,		TI000, TI010,	
OCD0B ^{Note 2} ,		TI50, TI51:	Timer input
OCD1A ^{Note 2} ,		TO00,	
OCD1B ^{Note 2} :	On chip debug input/output	TO50, TO51,	
P00, P01:	Port 0	TOH0, TOH1:	Timer output
P10 to P17:	Port 1	TxD0, TxD6:	Transmit data
P20 to P23:	Port 2	V _{DD} :	Power supply
P30 to P33:	Port 3	V _{SS} :	Ground
		X1, X2:	Crystal oscillator (main system clock)

- Notes**
1. 36-pin plastic FLGA (FC-AA3 type) only
 2. μ PD78F0503D (product with on-chip debug function) only

1.5 78K0/Kx2 Series Lineup

ROM	RAM	78K0/KB2	78K0/KB2		78K0/KD2	78K0/KE2	78K0/KF2
		30/36 Pins	44 Pins	48 Pins	52 Pins	64 Pins	80 Pins
128 KB	7 KB	–	–	–	μ PD78F0527D ^{Note}	μ PD78F0537D ^{Note}	μ PD78F0547D ^{Note}
					μ PD78F0527	μ PD78F0537	μ PD78F0547
96 KB	5 KB	–	–	–	μ PD78F0526	μ PD78F0536	μ PD78F0546
60 KB	3 KB	–	–	μ PD78F0515D ^{Note}	μ PD78F0525	μ PD78F0535	μ PD78F0545
				μ PD78F0515			
48 KB	2 KB	–	–	μ PD78F0514	μ PD78F0524	μ PD78F0534	μ PD78F0544
32 KB	1 KB	μ PD78F0503D ^{Note}	μ PD78F0513D ^{Note}	μ PD78F0513	μ PD78F0523	μ PD78F0533	–
		μ PD78F0503	μ PD78F0513				
24 KB	1 KB	μ PD78F0502	μ PD78F0512		μ PD78F0522	μ PD78F0532	–
16 KB	768 B	μ PD78F0501	μ PD78F0511		μ PD78F0521	μ PD78F0531	–
8 KB	512 B	μ PD78F0500	–		–	–	–

Note Product with on-chip debug function

The list of functions in the 78K0/Kx2 Series is shown below.

(1/2)

Part Number		78K0/KB2				78K0/KC2								
		30/36 Pins				44 Pins			48 Pins					
Flash memory (KB)		8	16	24	32	16	24	32	16	24	32	48	60	
RAM (KB)		0.5	0.75	1	1	0.75	1	1	0.75	1	1	2	3	
Bank (flash memory)		-												
Power supply voltage		V _{DD} = 1.8 to 5.5 V												
Regulator		Provided												
Minimum instruction execution time		0.1 μs (20 MHz: V _{DD} = 4.0 to 5.5 V)/0.2 μs (10 MHz: V _{DD} = 2.7 to 5.5 V)/0.4 μs (5 MHz: V _{DD} = 1.8 to 5.5 V)												
Clock	Main	High-speed system 20 MHz: V _{DD} = 4.0 to 5.5 V/10 MHz: V _{DD} = 2.7 to 5.5 V/5 MHz: V _{DD} = 1.8 to 5.5 V												
		Internal high-speed oscillation 8 MHz (TYP.): V _{DD} = 1.8 to 5.5 V												
	Subsystem					-								
	Internal low-speed oscillation					240 kHz (TYP.): V _{DD} = 1.8 to 5.5 V								
Port	Total		23				37			41				
	N-ch O.D. (6 V tolerance)		2				4			4				
Timer	16 bits (TM0)		1 ch											
	8 bits (TM5)		2 ch											
	8 bits (TMH)		2 ch											
	Watch		-					1 ch						
	WDT		1 ch											
Serial interface	3-wire CSI		-											
	Automatic transmit/receive 3-wire CSI		-											
	UART/3-wire CSI ^{Note}		1 ch											
	UART supporting LIN-bus		1 ch											
	I ² C bus		1 ch											
10-bit A/D		4 ch				8 ch								
Interrupt	External		6				7			8				
	Internal		14				16							
Key interrupt		-					4 ch							
Reset	RESET pin		Provided											
	POC		1.59 V ±0.15 V (rise time to 1.8 V: 3.6 ms (MIN.))											
	LVI		The detection level of the supply voltage is selectable in 16 steps.											
	WDT		Provided											
Clock output/buzzer output		-						Clock output only						
Multiplier/divider		-						Provided						
On-chip debug function		μPD78F0503D only				μPD78F0513D only			μPD78F0515D only					
Operating ambient temperature		T _A = -40 to +85°C												

<R>

Note Select either of the functions of these alternate-function pins.

Part Number		78K0/KD2						78K0/KE2						78K0/KF2					
		52 Pins						64 Pins						80 Pins					
Flash memory (KB)		16	24	32	48	60	96	128	16	24	32	48	60	96	128	48	60	96	128
RAM (KB)		0.75	1	1	2	3	5	7	0.75	1	1	2	3	5	7	2	3	5	7
Bank (flash memory)		-						4	6	-						4	6		
Power supply voltage		V _{DD} = 1.8 to 5.5 V																	
Regulator		Provided																	
Minimum instruction execution time		0.1 μs (20 MHz: V _{DD} = 4.0 to 5.5 V)/0.2 μs (10 MHz: V _{DD} = 2.7 to 5.5 V)/ 0.4 μs (5 MHz: V _{DD} = 1.8 to 5.5 V)																	
Clock	Main	High-speed system		20 MHz: V _{DD} = 4.0 to 5.5 V/10 MHz: V _{DD} = 2.7 to 5.5 V/5 MHz: V _{DD} = 1.8 to 5.5 V															
		Internal high-speed oscillation		8 MHz (TYP.): V _{DD} = 1.8 to 5.5 V															
	Subsystem		32.768 kHz (TYP.): V _{DD} = 1.8 to 5.5 V																
	Internal low-speed oscillation		240 kHz (TYP.): V _{DD} = 1.8 to 5.5 V																
Port	Total		45						55						71				
	N-ch O.D. (6 V tolerance)		4						4						4				
Timer	16 bits (TM0)		1 ch						2 ch										
	8 bits (TM5)		2 ch																
	8 bits (TMH)		2 ch																
	Watch		1 ch																
	WDT		1 ch																
Serial interface	3-wire CSI		-						1 ch										
	Automatic transmit/receive 3-wire CSI		-						1 ch										
	UART/3-wire CSI ^{Note}		1 ch																
	UART supporting LIN-bus		1 ch																
	I ² C bus		1 ch																
10-bit A/D		8 ch																	
Interrupt	External		8						9										
	Internal		16						19						20				
Key interrupt		8 ch																	
Reset	RESET pin		Provided																
	POC		1.59 V ±0.15 V (rise time to 1.8 V: 3.6 ms (MIN.))																
	LVI		The detection level of the supply voltage is selectable in 16 steps.																
	WDT		Provided																
Clock output/buzzer output		Clock output only						Provided											
Multiplier/divider		-						Provided											
On-chip debug function		μPD78F0527D only						μPD78F0537D only						μPD78F0547D only					
Operating ambient temperature		T _A = -40 to +85°C																	

<R>

Note Select either of the functions of these alternate-function pins.

1.6 Block Diagram

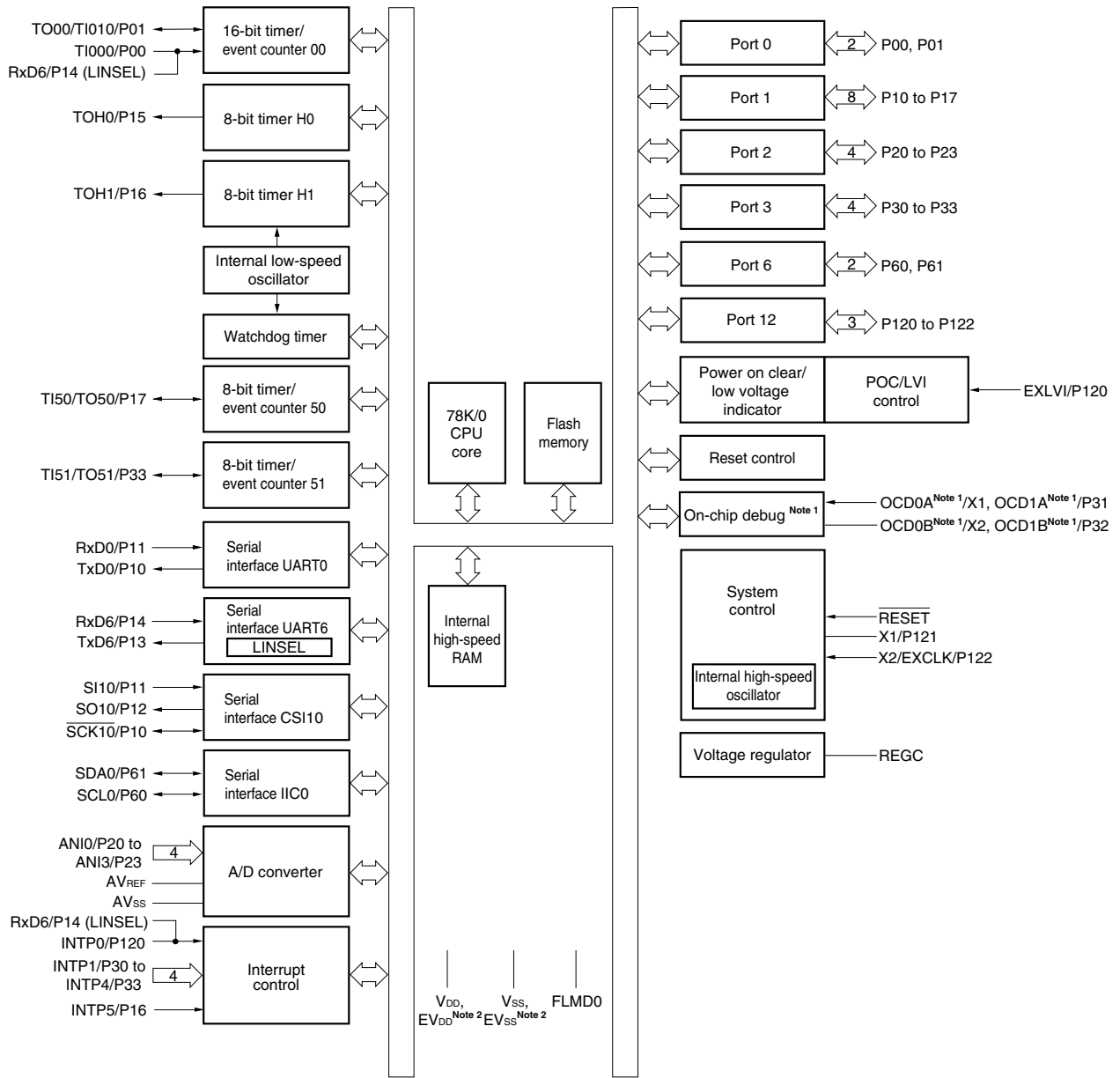

- Notes**
1. Available only in the μ PD78F0503D (product with on-chip debug function).
 2. Available only in the 36-pin plastic FLGA (FC-AA3 type).

1.7 Outline of Functions

(1/2)

Item		μPD78F0500	μPD78F0501	μPD78F0502	μPD78F0503	μPD78F0503D
Internal memory	Flash memory (self-programming supported) ^{Note 1}	8 KB	16 KB	24 KB	32 KB	
	High-speed RAM ^{Note 1}	512 bytes	768 bytes	1 KB		
Memory space		64 KB				
Main system clock (oscillation frequency)	High-speed system clock	X1 (crystal/ceramic) oscillation, external main system clock input (EXCLK) 1 to 20 MHz: V _{DD} = 4.0 to 5.5 V, 1 to 10 MHz: V _{DD} = 2.7 to 5.5 V, 1 to 5 MHz: V _{DD} = 1.8 to 5.5 V				
	Internal high-speed oscillation clock	Internal oscillation 8 MHz (TYP.): V _{DD} = 1.8 to 5.5 V				
Internal low-speed oscillation clock (for TMH1, WDT)		Internal oscillation 240 kHz (TYP.): V _{DD} = 1.8 to 5.5 V				
General-purpose registers		8 bits × 32 registers (8 bits × 8 registers × 4 banks)				
Minimum instruction execution time		0.1 μs (high-speed system clock: @ f _{XH} = 20 MHz operation)				
		0.25 μs (internal high-speed oscillation clock: @ f _{RH} = 8 MHz (TYP.) operation)				
Instruction set		<ul style="list-style-type: none"> • 8-bit operation, 16-bit operation • Multiply/divide (8 bits × 8 bits, 16 bits ÷ 8 bits) • Bit manipulate (set, reset, test, and Boolean operation) • BCD adjust, etc. 				
I/O ports		Total: <u>23</u> CMOS I/O: 21 N-ch open-drain I/O (6 V tolerance): 2				
Timers		<ul style="list-style-type: none"> • 16-bit timer/event counter: 1 channel • 8-bit timer/event counter: 2 channels • 8-bit timer: 2 channels • Watchdog timer: 1 channel 				
		Timer outputs	5 (PWM output: 4, PPG output: 1)			
A/D converter		10-bit resolution × 4 channels (AV _{REF} = 2.3 to 5.5 V))				
Serial interface		<ul style="list-style-type: none"> • UART supporting LIN-bus: 1 channel • 3-wire serial I/O/UART^{Note 2}: 1 channel • I²C bus: 1 channel 				
Vectored interrupt sources	Internal	14				
	External	6				
Reset		<ul style="list-style-type: none"> • Reset using RESET pin • Internal reset by watchdog timer • Internal reset by power-on-clear • Internal reset by low-voltage detector 				
On-chip debug function		None				Provided
Power supply voltage		V _{DD} = 1.8 to 5.5 V				

Notes 1. The internal flash memory capacity, and internal high-speed RAM capacity can be changed using the internal memory size switching register (IMS).

2. Select either of the functions of these alternate-function pins.

<R>

Item	μ PD78F0500	μ PD78F0501	μ PD78F0502	μ PD78F0503	μ PD78F0503D
Operating ambient temperature	$T_A = -40$ to $+85^\circ\text{C}$				
Package	<ul style="list-style-type: none"> 30-pin plastic SSOP (7.62 mm (300)) 36-pin plastic FLGA (4x4) 				

An outline of the timer is shown below.

		16-Bit Timer/ Event Counter 00	8-Bit Timer/Event Counters 50 and 51		8-Bit Timers H0 and H1		Watchdog Timer
		TM00	TM50	TM51	TMH0	TMH1	
Function	Interval timer	1 channel	1 channel	1 channel	1 channel	1 channel	–
	External event counter	1 channel	1 channel	1 channel	–	–	–
	PPG output	1 output	–	–	–	–	–
	PWM output	–	1 output	1 output	1 output	1 output	–
	Pulse width measurement	2 inputs	–	–	–	–	–
	Square-wave output	1 output	1 output	1 output	1 output	1 output	–
	Carrier generator	–	–	–	–	1 output ^{Note}	–
Watchdog timer	–	–	–	–	–	1 channel	
Interrupt source		2	1	1	1	1	–

Note TM51 and TMH1 can be used in combination as a carrier generator mode.

CHAPTER 2 PIN FUNCTIONS

2.1 Pin Function List

There are two types of pin I/O buffer power supplies in the 30-pin plastic SSOP (MC-5A4 and MC-CAB types): AVREF, and VDD, and three types of pin I/O buffer power supplies in the 36-pin plastic FLGA (FC-AA3 type): AVREF, EVDD, and VDD. The relationship between these power supplies and the pins is shown below.

Table 2-1. Pin I/O Buffer Power Supplies

Power Supply	Corresponding Pins	
	30-pin SSOP	36-pin FLGA
AVREF	P20 to P23	P20 to P23
EVDD	–	Port pins other than P20 to P23, P121, and P122
VDD	Pins other than P20 to P23	<ul style="list-style-type: none"> • P121 and P122 • Pins other than port

(1) Port functions (1/2)

Function Name	I/O	Function	After Reset	Alternate Function
P00	I/O	Port 0. 2-bit I/O port. Input/output can be specified in 1-bit units. Use of an on-chip pull-up resistor can be specified by a software setting.	Input port	TI000
P01				TI010/TO00
P10	I/O	Port 1. 8-bit I/O port. Input/output can be specified in 1-bit units. Use of an on-chip pull-up resistor can be specified by a software setting.	Input port	SCK10/TxD0
P11				SI10/RxD0
P12				SO10
P13				TxD6
P14				RxD6
P15				TOH0
P16				TOH1/INTP5
P17				TI50/TO50
P20 to P23	I/O	Port 2. 4-bit I/O port. Input/output can be specified in 1-bit units.	Analog input	ANI0 to ANI3
P30	I/O	Port 3. 4-bit I/O port. Input/output can be specified in 1-bit units. Use of an on-chip pull-up resistor can be specified by a software setting.	Input port	INTP1
P31				INTP2/OC1A ^{Note}
P32				INTP3/OC1B ^{Note}
P33				TI51/TO51/INTP4
P60	I/O	Port 6. 2-bit I/O port. Output is N-ch open-drain output (6 V tolerance). Input/output can be specified in 1-bit units.	Input port	SCL0
P61				SDA0

Note μ PD78F0503D only

(1) Port functions (2/2)

Function Name	I/O	Function	After Reset	Alternate Function
P120	I/O	Port 12. 3-bit I/O port. Input/output can be specified in 1-bit units. Only for P120, use of an on-chip pull-up resistor can be specified by a software setting.	Input port	INTP0/EXLVI
P121				X1/OCD0A ^{Note}
P122				X2/EXCLK/OCD0B ^{Note}

Note μ PD78F0503D only

(2) Non-port functions (1/2)

Function Name	I/O	Function	After Reset	Alternate Function
ANI0 to ANI3	Input	A/D converter analog input	Analog input	P20 to P23
EXLVI	Input	Potential input for external low-voltage detection	Input port	P120/INTP0
FLMD0	–	Flash memory programming mode setting	–	–
INTP0	Input	External interrupt request input for which the valid edge (rising edge, falling edge, or both rising and falling edges) can be specified	Input port	P120/EXLVI
INTP1				P30
INTP2				P31/OCD1A ^{Note}
INTP3				P32/OCD1B ^{Note}
INTP4				P33/TI51/TO51
INTP5				P16/TOH1
REGC	–	Connecting regulator output (2.5 V) stabilization capacitance for internal operation. Connect to V_{SS} via a capacitor (0.47 to 1 μ F: recommended).	–	–
$\overline{\text{RESET}}$	Input	System reset input	–	–
RxD0	Input	Serial data input to UART0	Input port	P11/SI10
RxD6	Input	Serial data input to UART6	Input port	P14
TxD0	Output	Serial data output from UART0	Input port	P10/ $\overline{\text{SCK10}}$
TxD6	Output	Serial data output from UART6	Input port	P13
$\overline{\text{SCK10}}$	I/O	Clock input/output for CSI10	Input port	P10/TxD0
SCL0	I/O	Clock input/output for I ² C	Input port	P60
SDA0	I/O	Serial data I/O for I ² C	Input port	P61
SI10	Input	Serial data input to CSI10	Input port	P11/RxD0
SO10	Output	Serial data output from CSI10	Input port	P12
TI000	Input	External count clock input to 16-bit timer/event counter 00 Capture trigger input to capture registers (CR000, CR010) of 16-bit timer/event counter 00	Input port	P00
TI010	Input	Capture trigger input to capture register (CR000) of 16-bit timer/event counter 00	Input port	P01/TO00
TI50	Input	External count clock input to 8-bit timer/event counter 50	Input port	P17/TO50
TI51		External count clock input to 8-bit timer/event counter 51		P33/TO51/INTP4

Note μ PD78F0503D only

<R>

(2) Non-port functions (2/2)

Function Name	I/O	Function	After Reset	Alternate Function
TO00	Output	16-bit timer/event counter 00 output	Input port	P01/TI010
TO50	Output	8-bit timer/event counter 50 output	Input port	P17/TI50
TO51		8-bit timer/event counter 51 output		P33/TI51/INTP4
TOH0	Output	8-bit timer H0 output	Input port	P15
TOH1		8-bit timer H1 output		P16/INTP5
X1	–	Connecting resonator for main system clock	Input port	P121/OCD0A ^{Note 1}
X2	–		Input port	P122/EXCLK/OCD0B ^{Note 1}
EXCLK	Input	External clock input for main system clock	Input port	P122/X2/OCD0B ^{Note 1}
<R> V _{DD}	–	For 30-pin SSOP: Positive power supply for pins other than P20 to P23 For 36-pin FLGA: Positive power supply for P121, P122, and non-port pins	–	–
EV _{DD} ^{Note 2}	–	Positive power supply for port pins other than P20 to P23, P121, and P122. Make the same potential as V _{DD} .	–	–
AV _{REF}	–	A/D converter reference voltage input and positive power supply for P20 to P23 and A/D converter	–	–
<R> V _{SS}	–	For 30-pin SSOP: Ground potential for pins other than P20 to P23 For 36-pin FLGA: Ground potential for P121, P122, and non-port pins	–	–
EV _{SS} ^{Note 2}	–	Ground potential for port pins other than P20 to P23, P121, and P122. Make the same potential as V _{SS} .	–	–
AV _{SS}	–	A/D converter ground potential. Make the same potential as V _{SS} .	–	–
OCD0A ^{Note 1}	Input	Connection for on-chip debug mode setting pins (μ PD78F0503D only)	Input port	P121/X1
OCD1A ^{Note 1}				P31/INTP2
OCD0B ^{Note 1}	–			P122/X2/EXCLK
OCD1B ^{Note 1}	–			P32/INTP3

- Notes**
1. μ PD78F0503D only
 2. 36-pin plastic FLGA (FC-AA3 type) only

2.2 Description of Pin Functions

2.2.1 P00 and P01 (port 0)

P00 and P01 function as a 2-bit I/O port. These pins also function as timer I/O.

The following operation modes can be specified in 1-bit units.

(1) Port mode

P00 and P01 function as a 2-bit I/O port. P00 and P01 can be set to input or output port in 1-bit units using port mode register 0 (PM0). Use of an on-chip pull-up resistor can be specified by pull-up resistor option register 0 (PU0).

(2) Control mode

P00 and P01 function as timer I/O.

(a) TI000

This is a pin for inputting an external count clock to 16-bit timer/event counter 00 and is also for inputting a capture trigger signal to the capture registers (CR000, CR010) of 16-bit timer/event counter 00.

(b) TI010

This is a pin for inputting a capture trigger signal to the capture register (CR000) of 16-bit timer/event counter 00.

(c) T000

This is a timer output pin of 16-bit timer/event counter 00.

2.2.2 P10 to P17 (port 1)

P10 to P17 function as an 8-bit I/O port. These pins also function as pins for external interrupt request input, serial interface data I/O, clock I/O, and timer I/O.

The following operation modes can be specified in 1-bit units.

(1) Port mode

P10 to P17 function as an 8-bit I/O port. P10 to P17 can be set to input or output port in 1-bit units using port mode register 1 (PM1). Use of an on-chip pull-up resistor can be specified by pull-up resistor option register 1 (PU1).

(2) Control mode

P10 to P17 function as external interrupt request input, serial interface data I/O, clock I/O, and timer I/O.

(a) SI10

This is a serial data input pin of serial interface CSI10.

(b) SO10

This is a serial data output pin of serial interface CSI10.

(c) $\overline{\text{SCK10}}$

This is a serial clock I/O pin of serial interface CSI10.

(d) RxD0

This is a serial data input pin of serial interface UART0.

(e) RxD6

This is a serial data input pin of serial interface UART6.

(f) TxD0

This is a serial data output pin of serial interface UART0.

(g) TxD6

This is a serial data output pin of serial interface UART6.

(h) TI50

This is the pin for inputting an external count clock to 8-bit timer/event counter 50.

(i) TO50

This is a timer output pin of 8-bit timer/event counter 50.

(j) TOH0, TOH1

These are the timer output pins of 8-bit timers H0 and H1.

(k) INTP5

This is an external interrupt request input pin for which the valid edge (rising edge, falling edge, or both rising and falling edges) can be specified.

2.2.3 P20 to P23 (port 2)

P20 to P23 function as a 4-bit I/O port. These pins also function as pins for A/D converter analog input.

The following operation modes can be specified in 1-bit units.

(1) Port mode

P20 to P23 function as a 4-bit I/O port. P20 to P23 can be set to input or output port in 1-bit units using port mode register 2 (PM2).

(2) Control mode

P20 to P23 function as A/D converter analog input pins (ANI0 to ANI3). When using these pins as analog input pins, see **(5) ANI0/P20 to ANI3/P23** in **10.6 Cautions for A/D Converter**.

Caution ANI0/P20 to ANI3/P23 are set in the analog input mode after release of reset.

2.2.4 P30 to P33 (port 3)

P30 to P33 function as a 4-bit I/O port. These pins also function as pins for external interrupt request input and timer I/O.

The following operation modes can be specified in 1-bit units.

(1) Port mode

P30 to P33 function as a 4-bit I/O port. P30 to P33 can be set to input or output port in 1-bit units using port mode register 3 (PM3). Use of an on-chip pull-up resistor can be specified by pull-up resistor option register 3 (PU3).

(2) Control mode

P30 to P33 function as external interrupt request input and timer I/O.

(a) INT1 to INT4

These are the external interrupt request input pins for which the valid edge (rising edge, falling edge, or both rising and falling edges) can be specified.

(b) TI51

This is an external count clock input pin to 8-bit timer/event counter 51.

(c) TO51

This is a timer output pin from 8-bit timer/event counter 51.

Cautions 1. In the products with an on-chip debug function (μ PD78F0503D), be sure to pull the P31/INT2/OCD1A^{Note} pin down before a reset release, to prevent malfunction.

2. For the products with an on-chip debug function (μ PD78F0503D), connect P31/INT2/OCD1A^{Note} as follows when writing the flash memory with a flash memory programmer.

- P31/INT2/OCD1A^{Note}: Connect to V_{SS} via a resistor (10 k Ω : recommended).

The above connection is not necessary when writing the flash memory by means of self programming.

<R>

<R>

Note OCD1A is provided to the μ PD78F0503D only.

Remark Only for the μ PD78F0503D, P31 and P32 can be used as on-chip debug mode setting pins (OCD1A, OCD1B) when the on-chip debug function is used. For how to connect an in-circuit emulator supporting on-chip debugging (QB-78K0MINI), see **CHAPTER 22 ON-CHIP DEBUG FUNCTION (μ PD78F0503D ONLY)**.

2.2.5 P60 and P61 (port 6)

P60 and P61 function as a 2-bit I/O port. These pins also function as pins for serial interface data I/O and clock I/O. The following operation modes can be specified in 1-bit units.

(1) Port mode

P60 and P61 function as a 2-bit I/O port. P60 and P61 can be set to input port or output port in 1-bit units using port mode register 6 (PM6).

Output is N-ch open-drain output (6 V tolerance).

(2) Control mode

P60 and P61 function as serial interface data I/O and clock I/O.

(a) SDA0

This is a serial data I/O pin for serial interface IIC0.

(b) SCL0

This is a serial clock I/O pin for serial interface IIC0.

2.2.6 P120 to P122 (port 12)

P120 to P122 function as a 3-bit I/O port. These pins also function as pins for external interrupt request input, potential input for external low-voltage detection, connecting resonator for main system clock, and external clock input for main system clock. The following operation modes can be specified in 1-bit units.

(1) Port mode

P120 to P122 function as a 3-bit I/O port. P120 to P122 can be set to input or output port using port mode register 12 (PM12). Only for P120, use of an on-chip pull-up resistor can be specified by pull-up resistor option register 12 (PU12).

(2) Control mode

P120 to P122 function as pins for external interrupt request input, potential input for external low-voltage detection, connecting resonator for main system clock, and external clock input for main system clock.

(a) INTPO

This functions as an external interrupt request input (INTPO) for which the valid edge (rising edge, falling edge, or both rising and falling edges) can be specified.

(b) EXLVI

This is a potential input pin for external low-voltage detection.

(c) X1, X2

These are the pins for connecting a resonator for main system clock.

(d) EXCLK

This is an external clock input pin for main system clock.

<R> **Caution** For the product with an on-chip debug function (μ PD78F0503D), connect P121/X1/OCD0A^{Note} as follows when writing the flash memory with a flash memory programmer.

- P121/X1/OCD0A^{Note}: When using this pin as a port, connect it to V_{SS} via a resistor (10 k Ω : recommended) (in the input mode) or leave it open (in the output mode).

The above connection is not necessary when writing the flash memory by means of self programming.

<R> **Note** OCD0A is provided to the μ PD78F0503D only.

Remark Only for the μ PD78F0503D, X1 and X2 can be used as on-chip debug mode setting pins (OCD0A, OCD0B) when the on-chip debug function is used. For how to connect an in-circuit emulator supporting on-chip debugging (QB-78K0MINI), see **CHAPTER 22 ON-CHIP DEBUG FUNCTION (μ PD78F0503D ONLY)**.

2.2.7 AV_{REF}

This is the A/D converter reference voltage input pin and the positive power supply pin of P20 to P23 and A/D converter.

When the A/D converter is not used, connect this pin directly to EV_{DD} or V_{DD}^{Note}.

Note Make the AV_{REF} pin the same potential as the V_{DD} pin when port 2 is used as a digital port.

2.2.8 AV_{SS}

This is the A/D converter ground potential pin. Even when the A/D converter is not used, always use this pin with the same potential as the V_{SS} pin.

2.2.9 $\overline{\text{RESET}}$

This is the active-low system reset input pin.

2.2.10 REGC

This is the pin for connecting regulator output (2.5 V) stabilization capacitance for internal operation. Connect this pin to V_{SS} via a capacitor (0.47 to 1 μF : recommended).

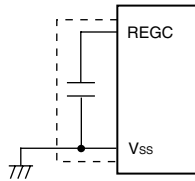

Caution Keep the wiring length as short as possible for the broken-line part in the above figure.

2.2.11 V_{DD} and EV_{DD}

For 30-pin SSOP, V_{DD} is the positive power supply pin for pins other than P20 to P23.

For 36-pin FLGA, V_{DD} is the positive power supply pin for P121, P122, and non-port pins.

EV_{DD} is the positive power supply pin for ports (36-pin plastic FLGA (FC-AA3 type) only).

Keep V_{DD} and EV_{DD} the same potential.

2.2.12 V_{SS} and EV_{SS}

For 30-pin SSOP, V_{SS} is the ground potential pin for pins other than P20 to P23.

For 36-pin FLGA, V_{SS} is the ground potential pin for P121, P122, and non-port pins.

EV_{SS} is the ground potential pin for ports (36-pin plastic FLGA (FC-AA3 type) only).

Keep V_{SS} and EV_{SS} the same potential.

2.2.13 FLMD0

This is a pin for setting flash memory programming mode.

Connect FLMD0 to V_{SS} in the normal operation mode.

In flash memory programming mode, connect this pin to the flash programmer.

<R>

2.3 Pin I/O Circuits and Recommended Connection of Unused Pins

Table 2-2 shows the types of pin I/O circuits and the recommended connections of unused pins.
See **Figure 2-1** for the configuration of the I/O circuit of each type.

Table 2-2. Pin I/O Circuit Types (1/2)

Pin Name	I/O Circuit Type	I/O	Recommended Connection of Unused Pins
P00/TI000	5-AH	I/O	Input: Independently connect to EV _{DD} or EV _{SS} via a resistor. Output: Leave open.
P01/TI010/TO00			
P10/ $\overline{\text{SCK10}}$ /TxD0			
P11/SI10/RxD0			
P12/SO10	5-AG		
P13/TxD6			
P14/RxD6	5-AH		
P15/TOH0	5-AG		
P16/TOH1/INTP5	5-AH		
P17/TI50/TO50			
P20/ANI0 to P23/ANI3 ^{Note 1}	11-G	Input	<Analog setting> Connect to AV _{REF} or AV _{SS} . <Digital setting> Input: Independently connect to EV _{DD} or EV _{SS} via a resistor. Output: Leave open.
P30/INTP1	5-AH	I/O	Input: Independently connect to EV _{DD} or EV _{SS} via a resistor. Output: Leave open.
<R> P31/INTP2/OCD1A ^{Note 2, 3}			
<R> P32/INTP2/OCD1B ^{Note 3}			
P33/TI51/TO51/INTP4			
P60/SCL0	13-AD		Input: Connect to EV _{SS} . Output: Leave this pin open at low-level output after clearing the output latch of the port to 0.
P61/SDA0			
P120/INTP0/EXLVI	5-AH		Input: Independently connect to EV _{DD} or EV _{SS} via a resistor. Output: Leave open.

Notes 1. P20/ANI0 to P23/ANI3 are set in the analog input mode after release of reset.

<R> 2. For the products with an on-chip debug function (μ PD78F0503D), connect P31/INTP2/OCD1A^{Note 3} as follows when writing the flash memory with a flash memory programmer.

- P31/INTP2/OCD1A^{Note 3}: Connect to V_{SS} via a resistor (10 k Ω : recommended).

The above connection is not necessary when writing the flash memory by means of self programming

<R> 3. OCD1A and OCD1B are provided to the μ PD78F0503D only.

Remark The 30-pin plastic SSOP (MC-5A4 and MC-CAB typess) does not have EV_{DD} pin and EV_{SS} pin. Therefore, transpose EV_{DD} and EV_{SS} to V_{DD} and V_{SS}, respectively.

Table 2-2. Pin I/O Circuit Types (2/2)

Pin Name	I/O Circuit Type	I/O	Recommended Connection of Unused Pins
<R> P121/X1/OCD0A ^{Note 1, 2, 5}	37	I/O	Input: Independently connect to V _{DD} or V _{SS} via a resistor. Output: Leave open.
P122/X2/EXCLK/OCD0B ^{Note 1, 5}			
AV _{REF}	–	–	Connect directly to EV _{DD} or V _{DD} ^{Note 3} .
AV _{SS}	–	–	Connect directly to EV _{SS} or V _{SS} .
<R> FLMD0	38	–	Connect to EV _{SS} or V _{SS} ^{Note 4} .
<R> RESET	2	Input	Connect to V _{DD} directly or via a resistor.

Notes 1. Use recommended connection above in I/O port mode (see **Figure 5-2 Format of Clock Operation Mode Select Register (OSCCTL)**) when these pins are not used.

<R> **2.** For the product with an on-chip debug function (μ PD78F0503D), connect P121/X1/OCD0A^{Note 5} as follows when writing the flash memory with a flash memory programmer.

- P121/X1/OCD0A^{Note 5}: When using this pin as a port, connect it to V_{SS} via a resistor (10 k Ω : recommended) (in the input mode) or leave it open (in the output mode).

The above connection is not necessary when writing the flash memory by means of self programming.

<R> **3.** Make the same potential as the V_{DD} pin when port 2 is used as a digital port.

<R> **4.** FLMD0 is a pin that is used to write data to the flash memory. To rewrite the data of the flash memory on-board, connect this pin to V_{SS} or EV_{SS} via a resistor (10 k Ω : recommended). The same applies when executing on-chip debugging with a product with an on-chip debug function (μ PD78F0503D).

<R> **5.** OCD0A and OCD0B are provided to the μ PD78F0503D only.

Remark The 30-pin plastic SSOP (MC-5A4 and MC-CAB types) does not have EV_{DD} pin and EV_{SS} pin. Therefore, transpose EV_{DD} and EV_{SS} to V_{DD} and V_{SS}, respectively.

Figure 2-1. Pin I/O Circuit List (1/2)

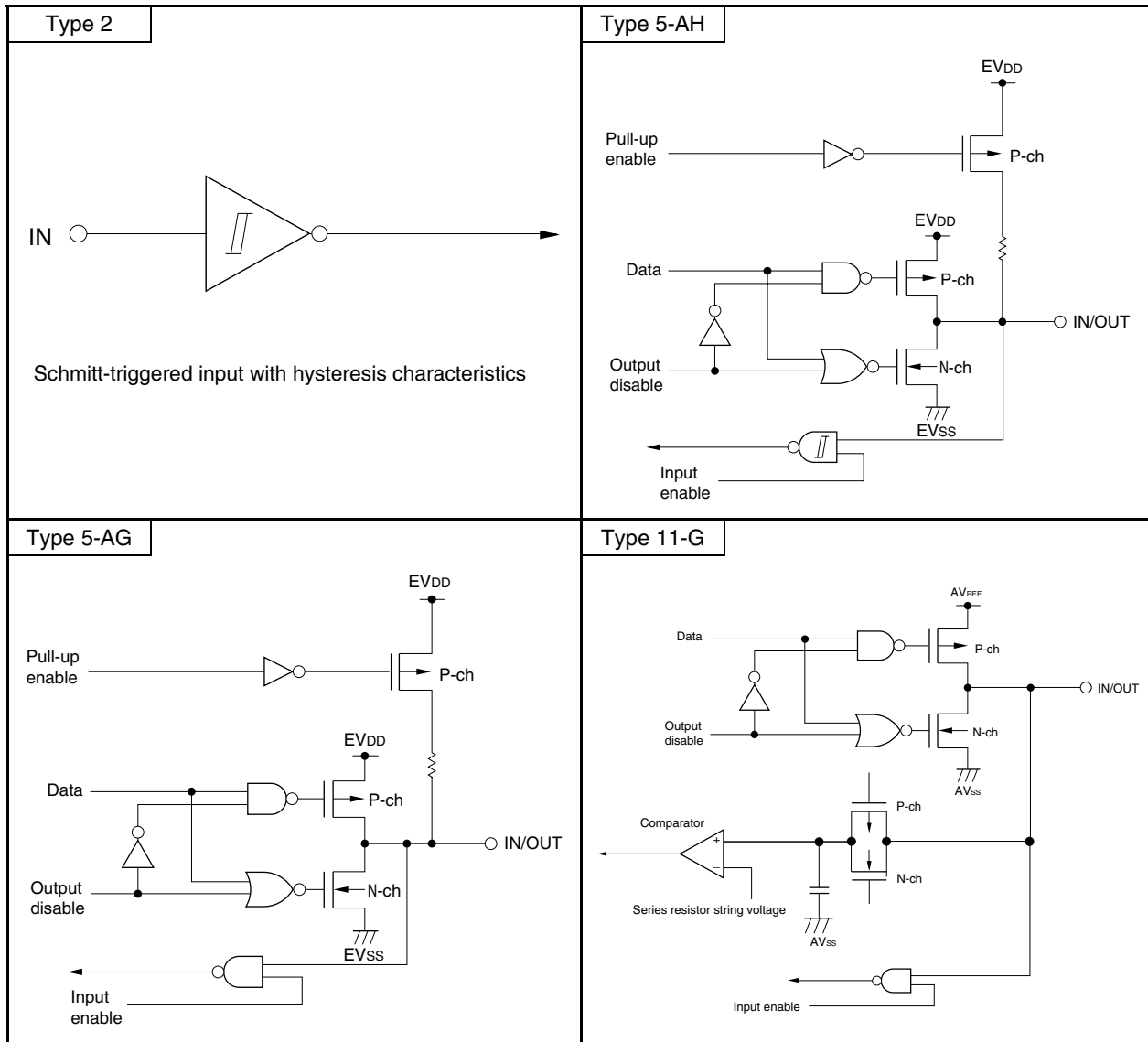

Remark There are not the EV_{DD} pin and the EV_{SS} pin in the 30-pin plastic SSOP (MC-5A4 and MC-CAB types). Therefore, transpose EV_{DD} and EV_{SS} to V_{DD} and V_{SS}, respectively, in the case of the 30-pin plastic SSOP (MC-5A4 and MC-CAB types).

Figure 2-1. Pin I/O Circuit List (2/2)

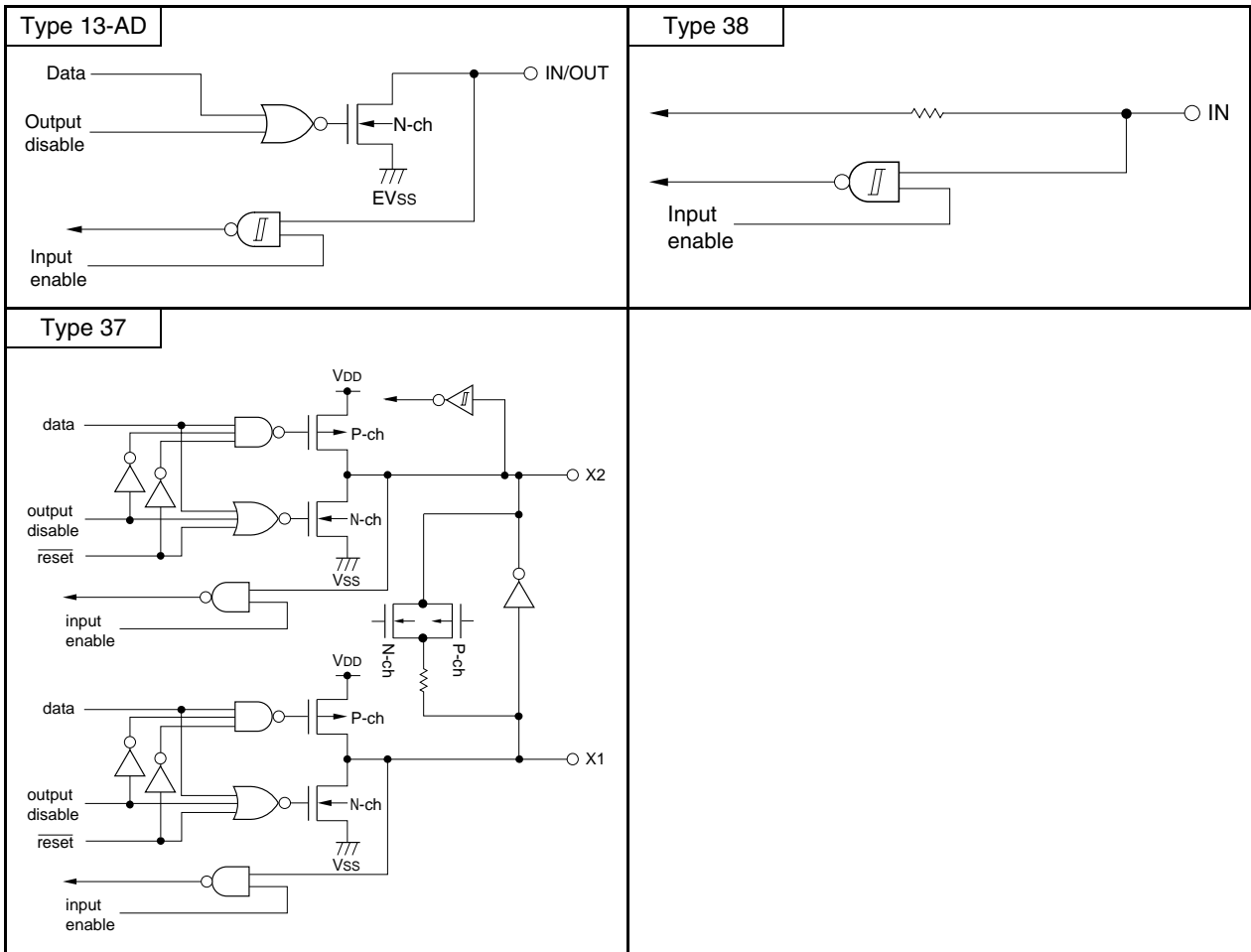

Remark There are not the EV_{DD} pin and the EV_{SS} pin in the 30-pin plastic SSOP (MC-5A4 and MC-CAB types). Therefore, transpose EV_{DD} and EV_{SS} to V_{DD} and V_{SS}, respectively, in the case of the 30-pin plastic SSOP (MC-5A4 and MC-CAB types).

CHAPTER 3 CPU ARCHITECTURE

3.1 Memory Space

Products in the 78K0/KB2 can access a 64 KB memory space. Figures 3-1 to 3-5 show the memory maps.

Caution Regardless of the internal memory capacity, the initial values of the internal memory size switching register (IMS) of all products in the 78K0/KB2 are fixed (IMS = CFH). Therefore, set the value corresponding to each product as indicated below.

Table 3-1. Set Values of Internal Memory Size Switching Register (IMS)

Flash Memory Version (78K0/KB2)	IMS	ROM Capacity	Internal High-Speed RAM Capacity
μ PD78F0500	42H	8 KB	512 bytes
μ PD78F0501	04H	16 KB	768 bytes
μ PD78F0502	C6H	24 KB	1 KB
μ PD78F0503, 78F0503D	C8H	32 KB	

Figure 3-1. Memory Map (μ PD78F0500)

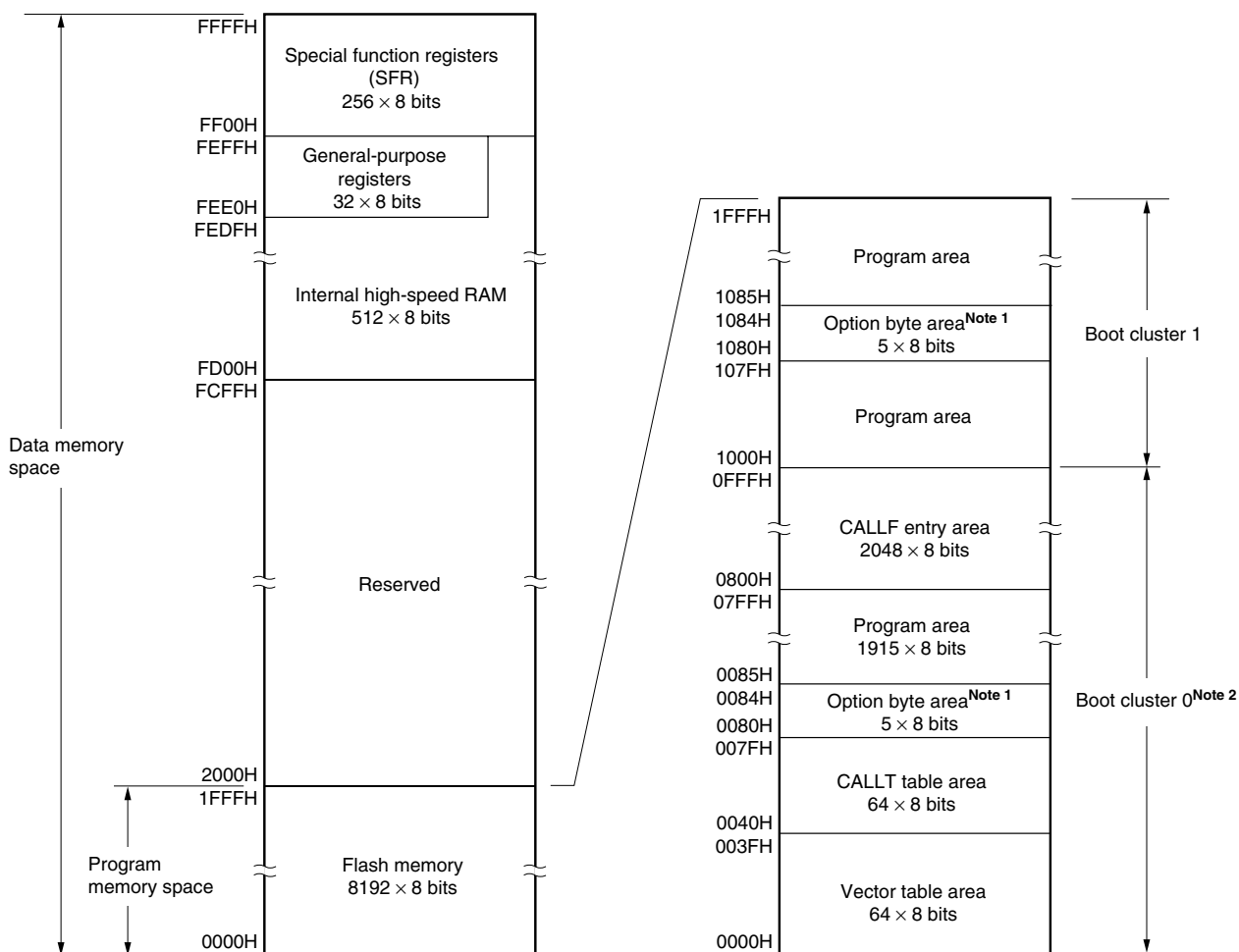

- Notes**
1. When boot swap is not used: Set the option bytes to 0080H to 0084H.
When boot swap is used: Set the option bytes to 0080H to 0084H and 1080H to 1084H.
 2. Writing boot cluster 0 can be prohibited depending on the setting of security (see **21.7 Security Setting**).

<R> **Remark** The flash memory is divided into blocks (one block = 1 KB). For the address values and block numbers, see **Table 3-2 Correspondence Between Address Values and Block Numbers in Flash Memory**.

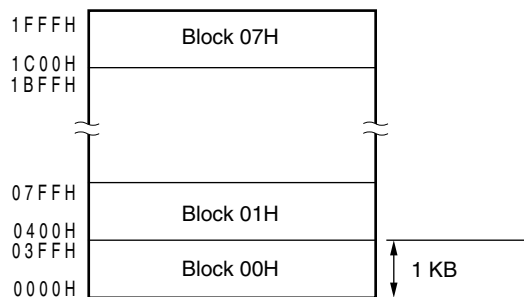
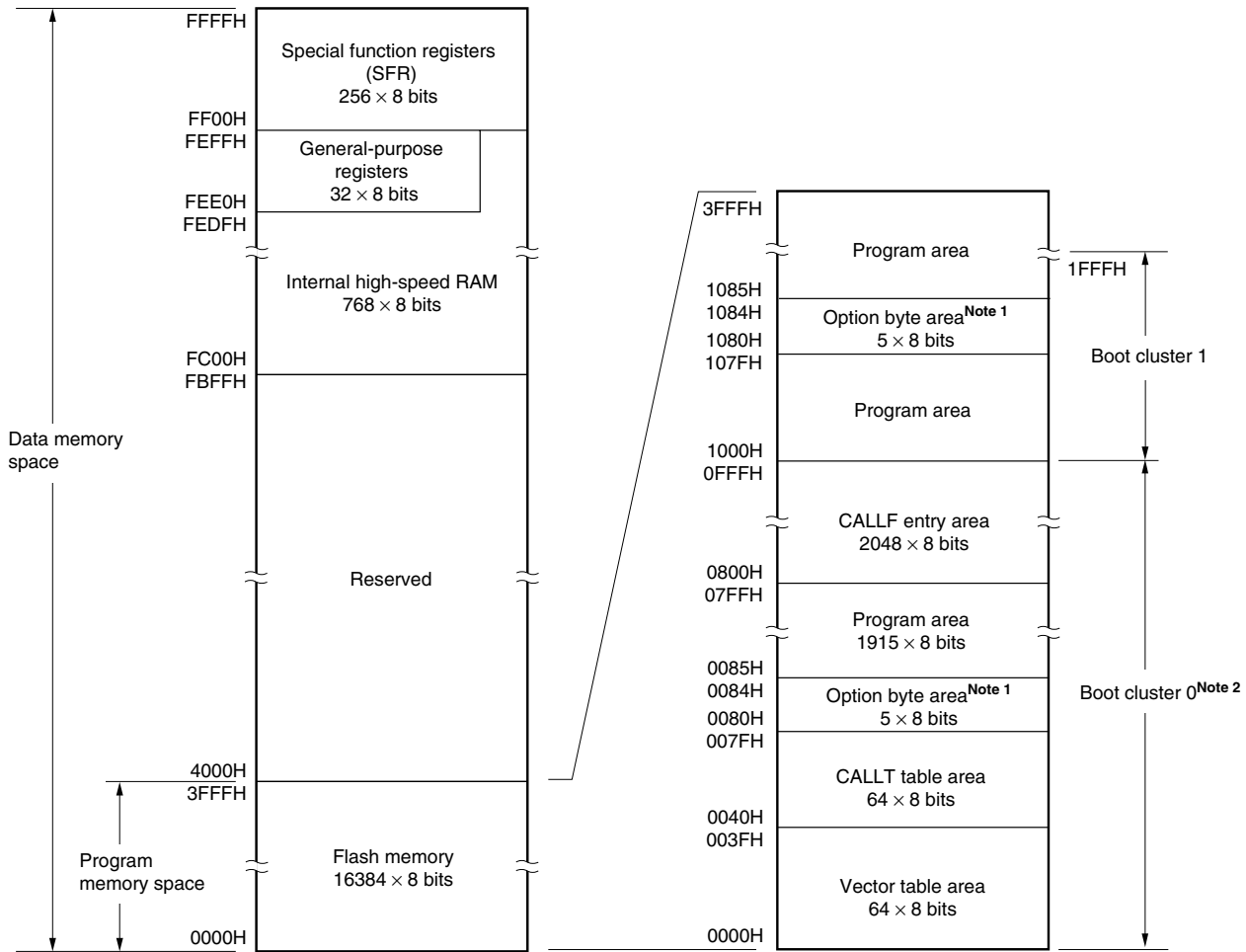

Figure 3-2. Memory Map (μ PD78F0501)



- Notes**
1. When boot swap is not used: Set the option bytes to 0080H to 0084H.
When boot swap is used: Set the option bytes to 0080H to 0084H and 1080H to 1084H.
 2. Writing boot cluster 0 can be prohibited depending on the setting of security (see **21.7 Security Setting**).

<R> **Remark** The flash memory is divided into blocks (one block = 1 KB). For the address values and block numbers, see **Table 3-2 Correspondence Between Address Values and Block Numbers in Flash Memory**.

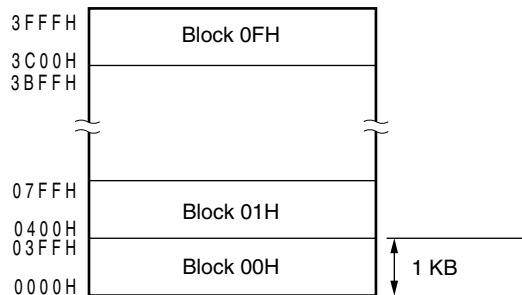
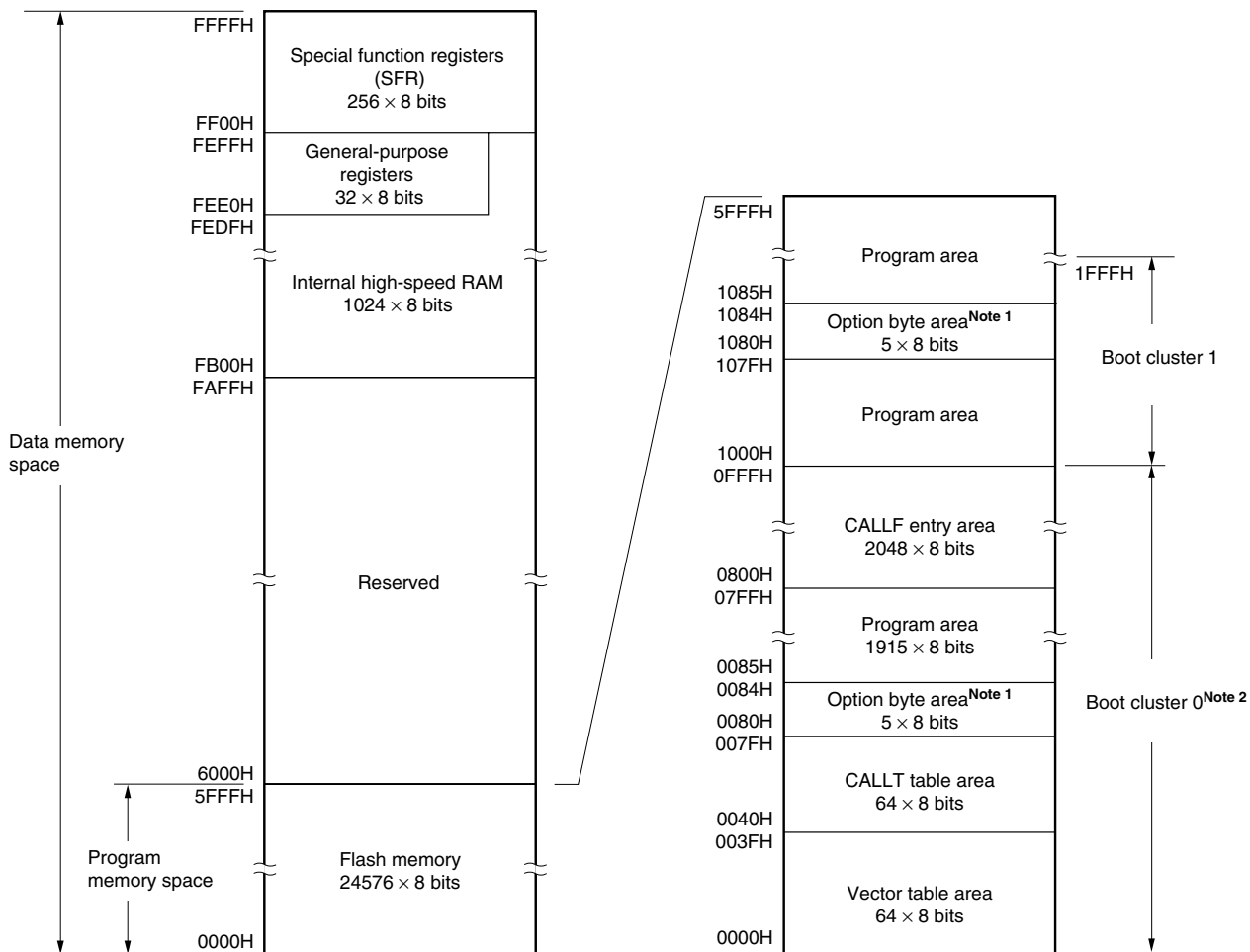

Figure 3-3. Memory Map (μ PD78F0502)



- Notes**
1. When boot swap is not used: Set the option bytes to 0080H to 0084H.
When boot swap is used: Set the option bytes to 0080H to 0084H and 1080H to 1084H.
 2. Writing boot cluster 0 can be prohibited depending on the setting of security (see 21.7 Security Setting).

<R> **Remark** The flash memory is divided into blocks (one block = 1 KB). For the address values and block numbers, see Table 3-2 Correspondence Between Address Values and Block Numbers in Flash Memory.

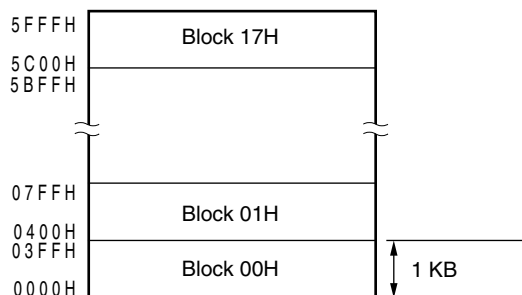
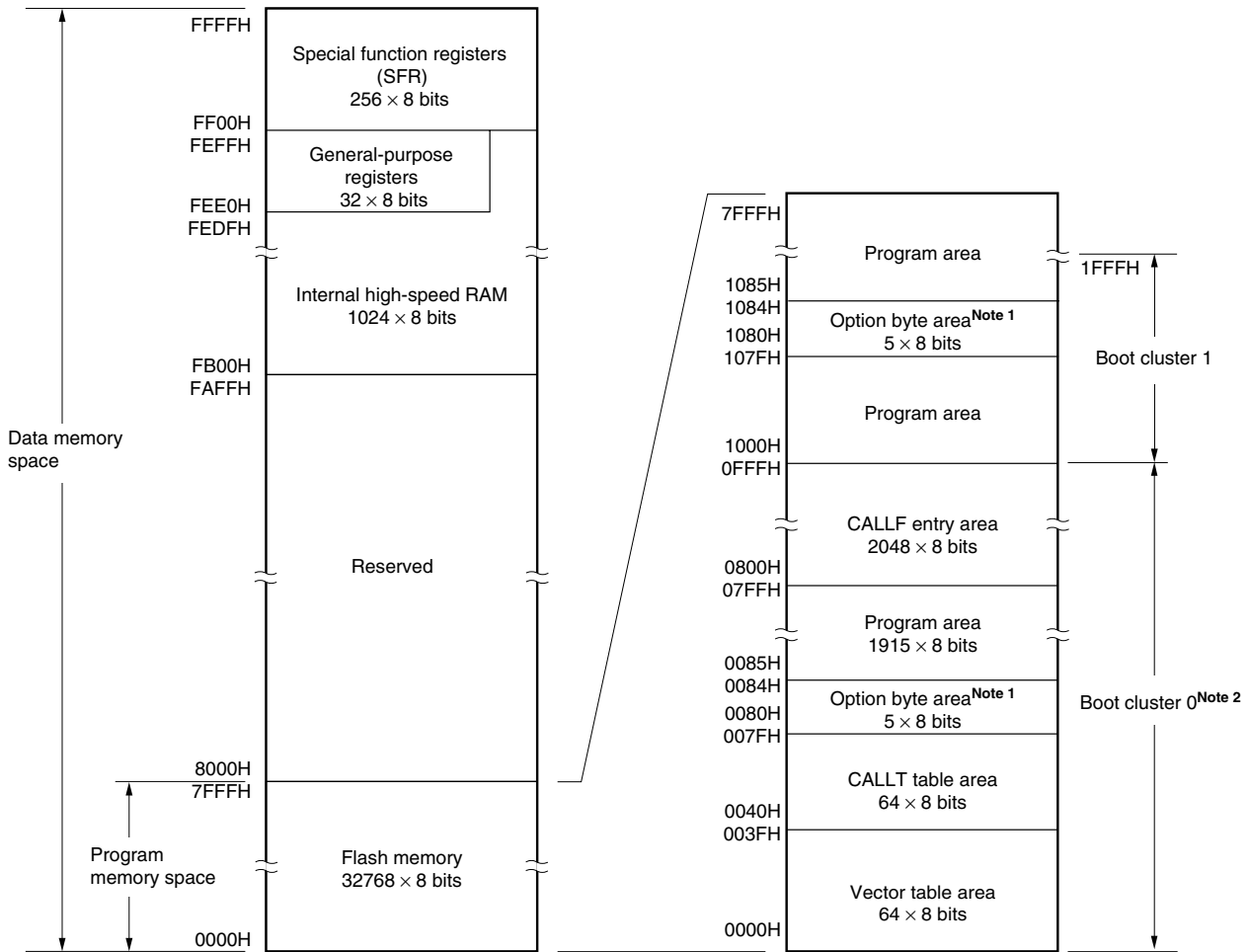

Figure 3-4. Memory Map (μ PD78F0503)



- Notes**
1. When boot swap is not used: Set the option bytes to 0080H to 0084H.
When boot swap is used: Set the option bytes to 0080H to 0084H and 1080H to 1084H.
 2. Writing boot cluster 0 can be prohibited depending on the setting of security (see **21.7 Security Setting**).

<R> **Remark** The flash memory is divided into blocks (one block = 1 KB). For the address values and block numbers, see **Table 3-2 Correspondence Between Address Values and Block Numbers in Flash Memory**.

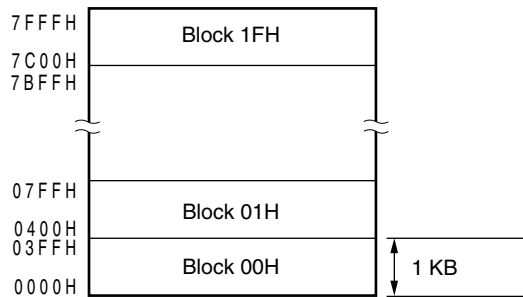
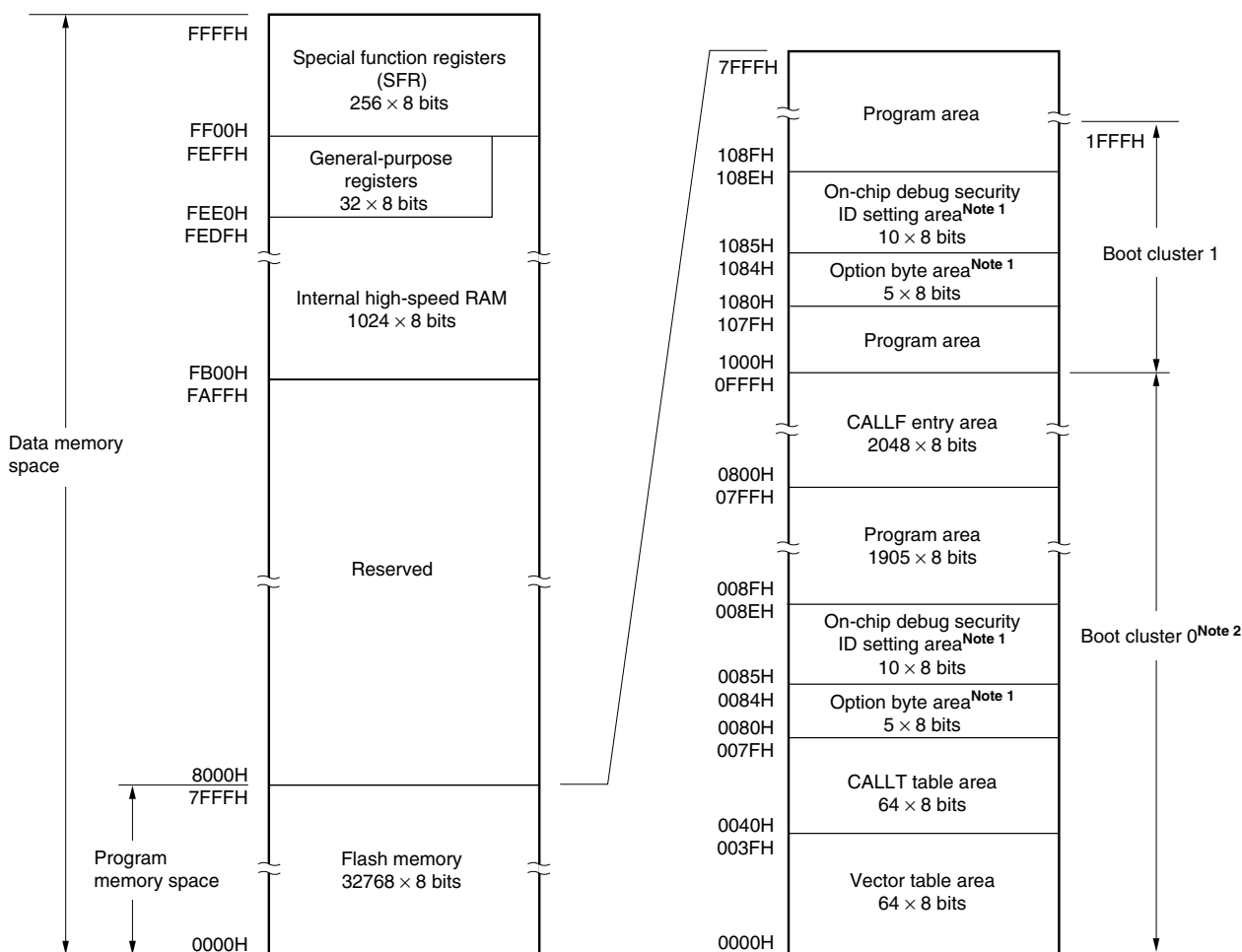
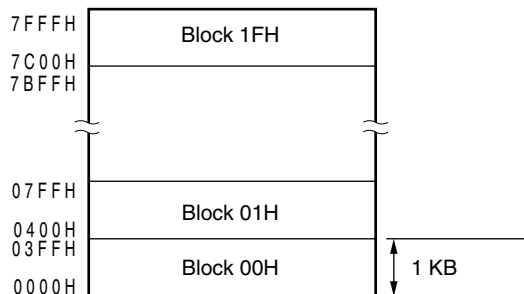

Figure 3-5. Memory Map (μ PD78F0503D)



- Notes**
- When boot swap is not used: Set the option bytes to 0080H to 0084H, and the on-chip debug security IDs to 0085H to 008EH.
When boot swap is used: Set the option bytes to 0080H to 0084H and 1080H to 1084H, and the on-chip debug security IDs to 0085H to 008EH and 1085H to 108EH.
 - Writing boot cluster 0 can be prohibited depending on the setting of security (see **21.7 Security Setting**).

<R> **Remark** The flash memory is divided into blocks (one block = 1 KB). For the address values and block numbers, see **Table 3-2 Correspondence Between Address Values and Block Numbers in Flash Memory**.



Correspondence between the address values and block numbers in the flash memory are shown below.

<R> **Table 3-2. Correspondence Between Address Values and Block Numbers in Flash Memory**

Address Value	Block Number	Address Value	Block Number
0000H to 03FFH	00H	4000H to 43FFH	10H
0400H to 07FFH	01H	4400H to 47FFH	11H
0800H to 0BFFH	02H	4800H to 4BFFH	12H
0C00H to 0FFFH	03H	4C00H to 4FFFH	13H
1000H to 13FFH	04H	5000H to 53FFH	14H
1400H to 17FFH	05H	5400H to 57FFH	15H
1800H to 1BFFH	06H	5800H to 5BFFH	16H
1C00H to 1FFFH	07H	5C00H to 5FFFH	17H
2000H to 23FFH	08H	6000H to 63FFH	18H
2400H to 27FFH	09H	6400H to 67FFH	19H
2800H to 2BFFH	0AH	6800H to 6BFFH	1AH
2C00H to 2FFFH	0BH	6C00H to 6FFFH	1BH
3000H to 33FFH	0CH	7000H to 73FFH	1CH
3400H to 37FFH	0DH	7400H to 77FFH	1DH
3800H to 3BFFH	0EH	7800H to 7BFFH	1EH
3C00H to 3FFFH	0FH	7C00H to 7FFFH	1FH

Remark μ PD78F0500: Block numbers 00H to 07H
 μ PD78F0501: Block numbers 00H to 0FH
 μ PD78F0502: Block numbers 00H to 17H
 μ PD78F0503, 78F0503D: Block numbers 00H to 1FH

3.1.1 Internal program memory space

The internal program memory space stores the program and table data. Normally, it is addressed with the program counter (PC).

78K0/KB2 products incorporate internal ROM (flash memory), as shown below.

Table 3-3. Internal ROM Capacity

Part Number	Internal ROM	
	Structure	Capacity
μ PD78F0500	Flash memory	8192 \times 8 bits (0000H to 1FFFH)
μ PD78F0501		16384 \times 8 bits (0000H to 3FFFH)
μ PD78F0502		24576 \times 8 bits (0000H to 5FFFH)
μ PD78F0503, 78F0503D		32768 \times 8 bits (0000H to 7FFFH)

The internal program memory space is divided into the following areas.

(1) Vector table area

The 64-byte area 0000H to 003FH is reserved as a vector table area. The program start addresses for branch upon reset or generation of each interrupt request are stored in the vector table area.

Of the 16-bit address, the lower 8 bits are stored at even addresses and the higher 8 bits are stored at odd addresses.

Table 3-4. Vector Table

Vector Table Address	Interrupt Source	Vector Table Address	Interrupt Source
0000H	RESET input, POC, LVI, WDT	0018H	INTCSI10/INTST0
0004H	INTLVI	001AH	INTTMH1
0006H	INTP0	001CH	INTTMH0
0008H	INTP1	001EH	INTTM50
000AH	INTP2	0020H	INTTM000
000CH	INTP3	0022H	INTTM010
000EH	INTP4	0024H	INTAD
0010H	INTP5	0026H	INTSR0
0012H	INTSRE6	002AH	INTTM51
0014H	INTSR6	0034H	INTIIC0
0016H	INTST6	003EH	BRK

(2) CALLT instruction table area

The 64-byte area 0040H to 007FH can store the subroutine entry address of a 1-byte call instruction (CALLT).

(3) Option byte area

A 5-byte area of 0080H to 0084H and 1080H to 1084H can be used as an option byte area. Set the option byte at 0080H to 0084H when the boot swap is not used, and at 0080H to 0084H and 1080H to 1084H when the boot swap is used. For details, see **CHAPTER 20 OPTION BYTE**.

(4) CALLF instruction entry area

The area 0800H to 0FFFH can perform a direct subroutine call with a 2-byte call instruction (CALLF).

(5) On-chip debug security ID setting area (μ PD78F0503D only)

A 10-byte area of 0085H to 008EH and 1085H to 108EH can be used as an on-chip debug security ID setting area. Set the on-chip debug security ID of 10 bytes at 0085H to 008EH when the boot swap is not used and at 0085H to 008EH and 1085H to 108EH when the boot swap is used. For details, see **CHAPTER 22 ON-CHIP DEBUG FUNCTION (μ PD78F0503D ONLY)**.

3.1.2 Internal data memory space

78K0/KB2 products incorporate the following RAMs.

Table 3-5. Internal High-Speed RAM Capacity

Part Number	Internal High-Speed RAM
μ PD78F0500	512 \times 8 bits (FD00H to FEFH)
μ PD78F0501	768 \times 8 bits (FC00H to FEFH)
μ PD78F0502	1024 \times 8 bits (FB00H to FEFH)
μ PD78F0503, 78F0503D	

The 32-byte area FEE0H to FEFH is assigned to four general-purpose register banks consisting of eight 8-bit registers per bank.

This area cannot be used as a program area in which instructions are written and executed.

The internal high-speed RAM can also be used as a stack memory.

3.1.3 Special function register (SFR) area

On-chip peripheral hardware special function registers (SFRs) are allocated in the area FF00H to FFFFH (see **Table 3-5 Special Function Register List** in **3.2.3 Special function registers (SFRs)**).

Caution Do not access addresses to which SFRs are not assigned.

3.1.4 Data memory addressing

Addressing refers to the method of specifying the address of the instruction to be executed next or the address of the register or memory relevant to the execution of instructions.

Several addressing modes are provided for addressing the memory relevant to the execution of instructions for the 78K0/KB2, based on operability and other considerations. For areas containing data memory in particular, special addressing methods designed for the functions of special function registers (SFR) and general-purpose registers are available for use. Figures 3-6 to 3-9 show correspondence between data memory and addressing. For details of each addressing mode, see **3.4 Operand Address Addressing**.

Figure 3-6. Correspondence Between Data Memory and Addressing (μ PD78F0500)

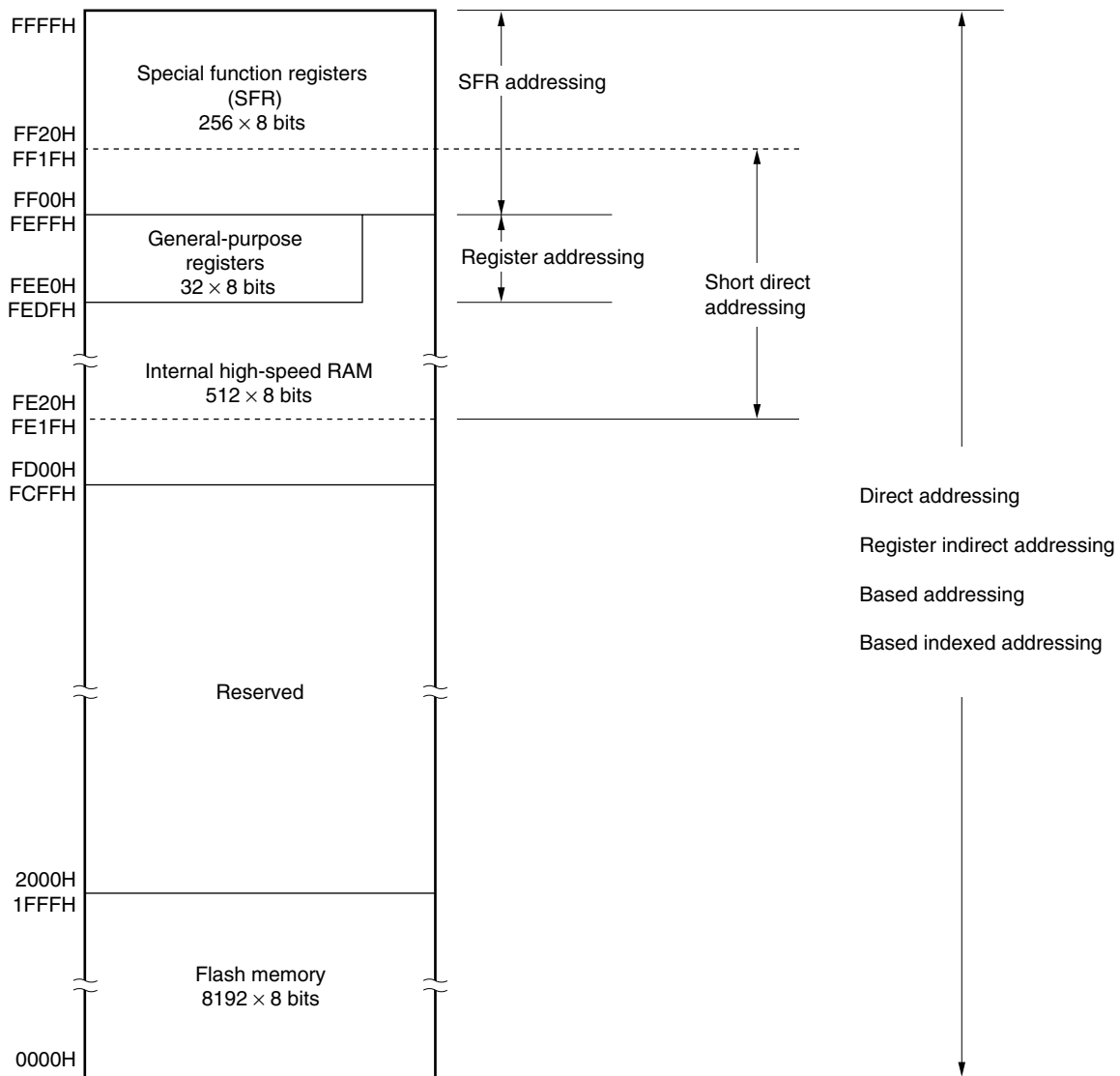

Figure 3-7. Correspondence Between Data Memory and Addressing (μ PD78F0501)

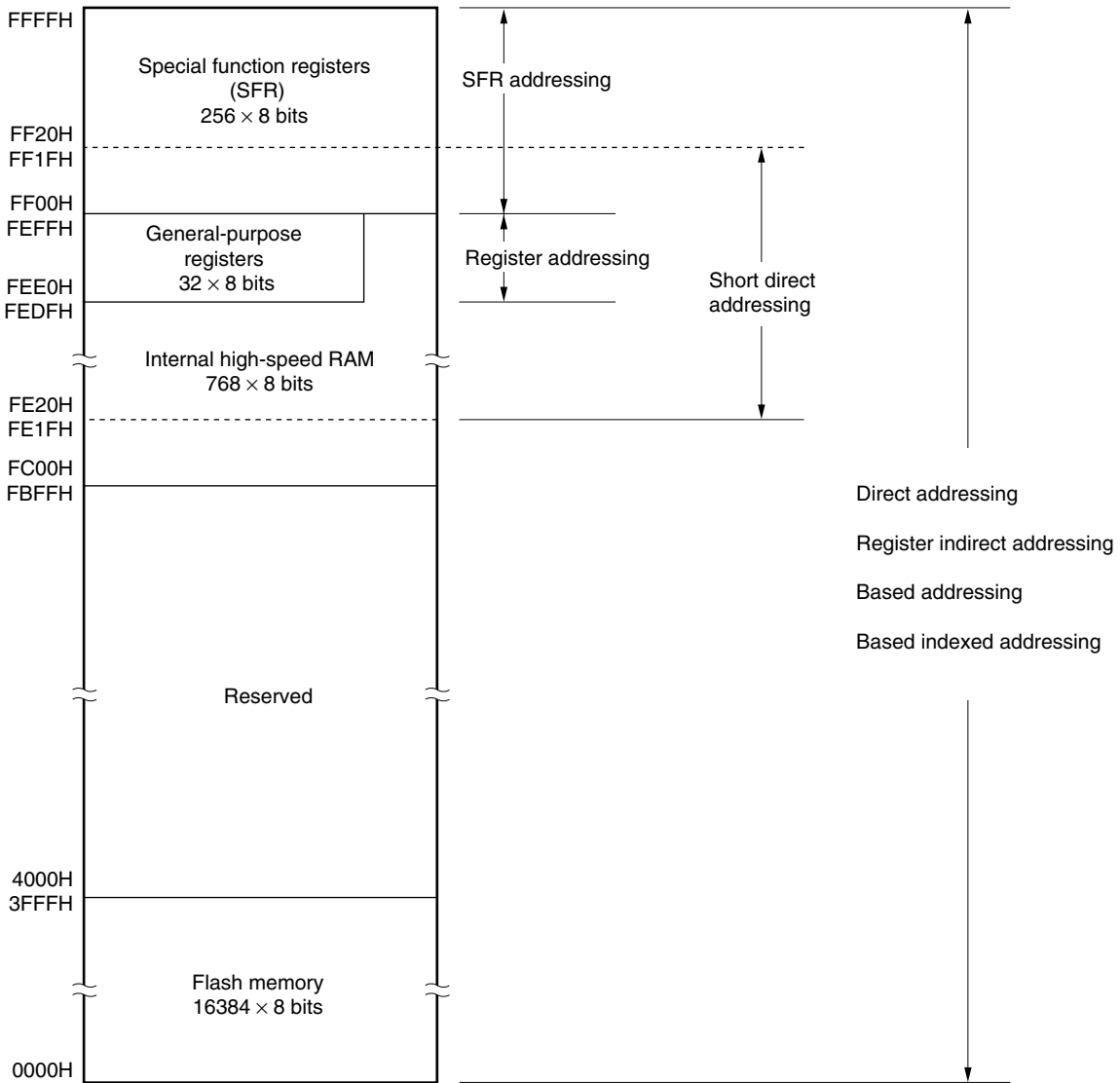

Figure 3-8. Correspondence Between Data Memory and Addressing (μ PD78F0502)

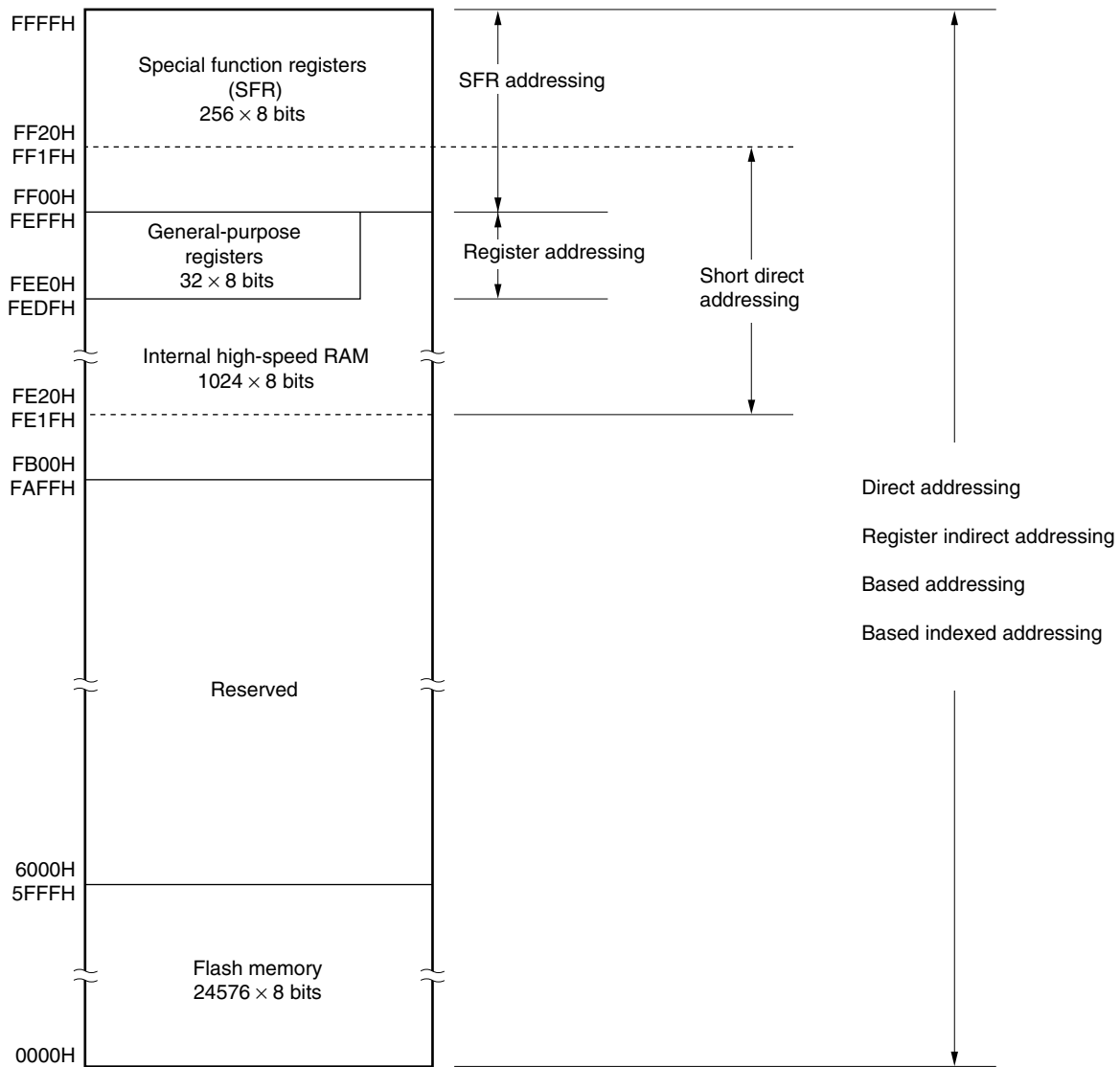
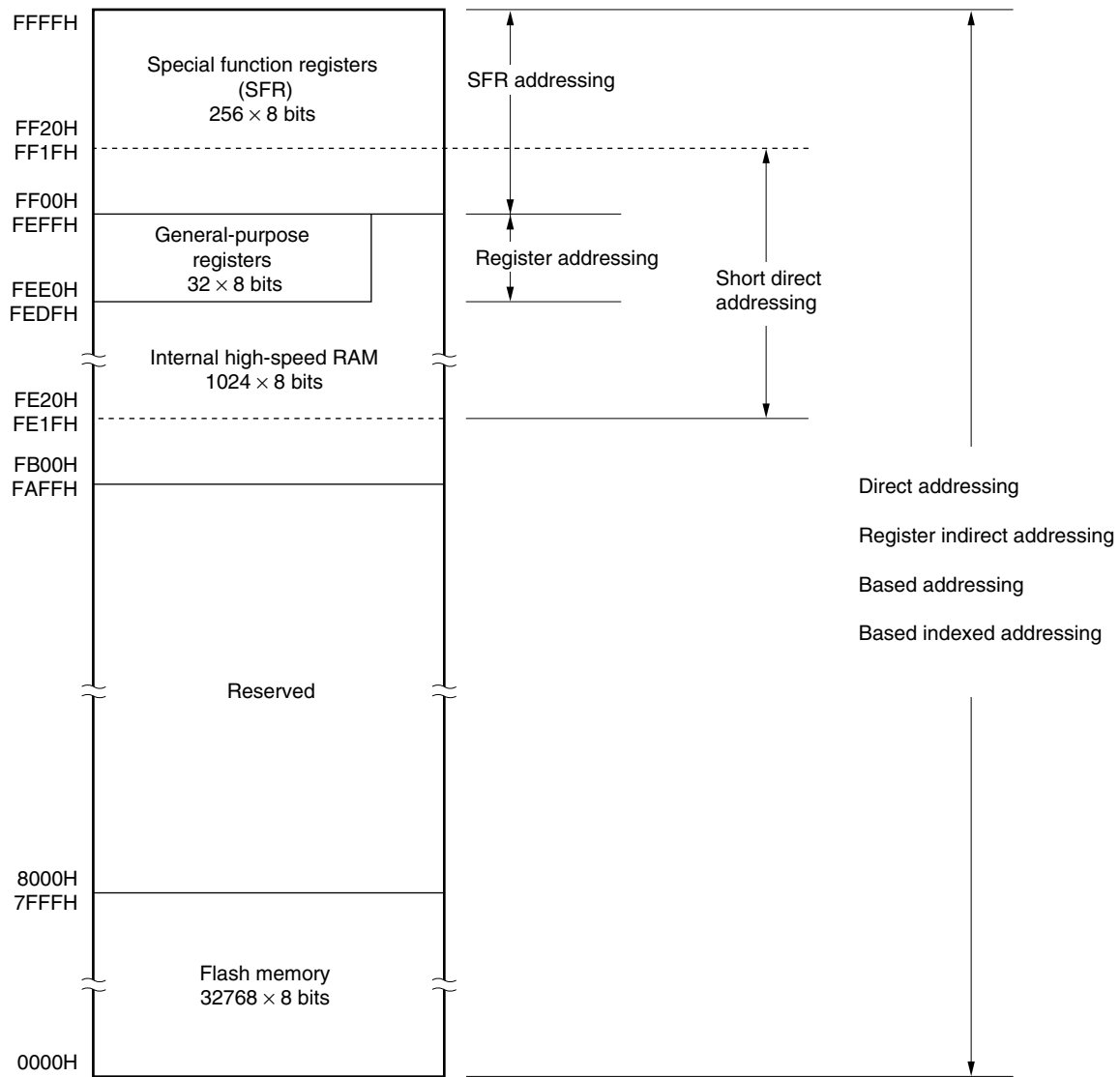

Figure 3-9. Correspondence Between Data Memory and Addressing (μ PD78F0503, 78F0503D)



3.2 Processor Registers

The 78K0/KB2 products incorporate the following processor registers.

3.2.1 Control registers

The control registers control the program sequence, statuses and stack memory. The control registers consist of a program counter (PC), a program status word (PSW) and a stack pointer (SP).

(1) Program counter (PC)

The program counter is a 16-bit register that holds the address information of the next program to be executed. In normal operation, PC is automatically incremented according to the number of bytes of the instruction to be fetched. When a branch instruction is executed, immediate data and register contents are set. Reset signal generation sets the reset vector table values at addresses 0000H and 0001H to the program counter.

Figure 3-10. Format of Program Counter

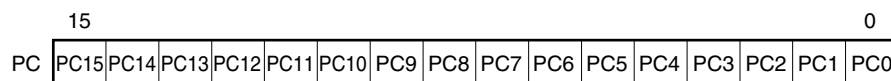

(2) Program status word (PSW)

The program status word is an 8-bit register consisting of various flags set/reset by instruction execution. Program status word contents are stored in the stack area upon interrupt request generation or PUSH PSW instruction execution and are restored upon execution of the RETB, RETI and POP PSW instructions. Reset signal generation sets PSW to 02H.

Figure 3-11. Format of Program Status Word

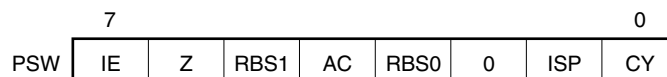

(a) Interrupt enable flag (IE)

This flag controls the interrupt request acknowledge operations of the CPU.

When 0, the IE flag is set to the interrupt disabled (DI) state, and all maskable interrupt requests are disabled. When 1, the IE flag is set to the interrupt enabled (EI) state and interrupt request acknowledgement is controlled with an in-service priority flag (ISP), an interrupt mask flag for various interrupt sources, and a priority specification flag.

The IE flag is reset (0) upon DI instruction execution or interrupt acknowledgement and is set (1) upon EI instruction execution.

(b) Zero flag (Z)

When the operation result is zero, this flag is set (1). It is reset (0) in all other cases.

(c) Register bank select flags (RBS0 and RBS1)

These are 2-bit flags to select one of the four register banks.

In these flags, the 2-bit information that indicates the register bank selected by SEL RBn instruction execution is stored.

(d) Auxiliary carry flag (AC)

If the operation result has a carry from bit 3 or a borrow at bit 3, this flag is set (1). It is reset (0) in all other cases.

(e) In-service priority flag (ISP)

This flag manages the priority of acknowledgeable maskable vectored interrupts. When this flag is 0, low-level vectored interrupt requests specified by a priority specification flag register (PR0L, PR0H, PR1L, PR1H) (see **15.3 (3) Priority specification flag registers (PR0L, PR0H, PR1L, PR1H)**) can not be acknowledged. Actual request acknowledgement is controlled by the interrupt enable flag (IE).

(f) Carry flag (CY)

This flag stores overflow and underflow upon add/subtract instruction execution. It stores the shift-out value upon rotate instruction execution and functions as a bit accumulator during bit operation instruction execution.

(3) Stack pointer (SP)

This is a 16-bit register to hold the start address of the memory stack area. Only the internal high-speed RAM area can be set as the stack area.

Figure 3-12. Format of Stack Pointer

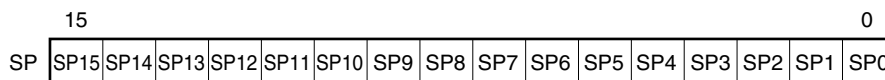

The SP is decremented ahead of write (save) to the stack memory and is incremented after read (restored) from the stack memory.

Each stack operation saves/restores data as shown in Figures 3-13 and 3-14.

Caution Since reset signal generation makes the SP contents undefined, be sure to initialize the SP before using the stack.

Figure 3-13. Data to Be Saved to Stack Memory

(a) PUSH rp instruction (when SP = FEE0H)

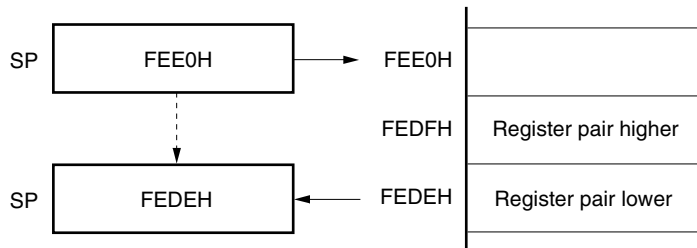

(b) CALL, CALLF, CALLT instructions (when SP = FEE0H)

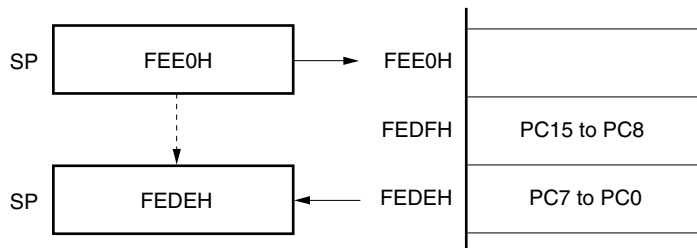

(c) Interrupt, BRK instructions (when SP = FEE0H)

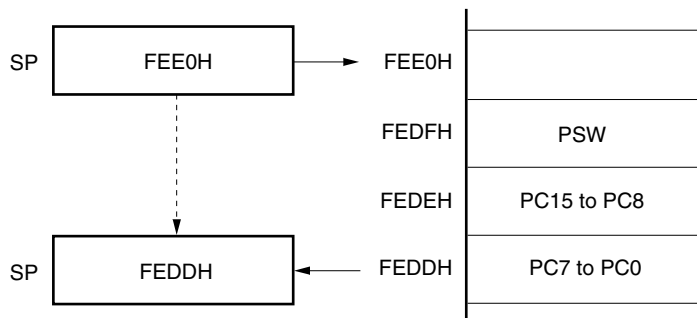
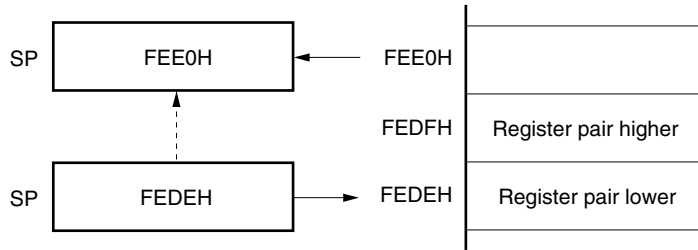
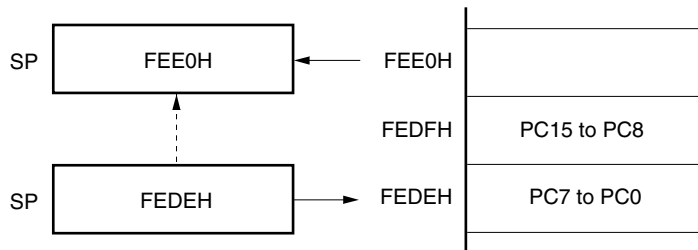

Figure 3-14. Data to Be Restored from Stack Memory

(a) POP rp instruction (when SP = FEDEH)



(b) RET instruction (when SP = FEDEH)



(c) RETI, RETB instructions (when SP = FEDDH)

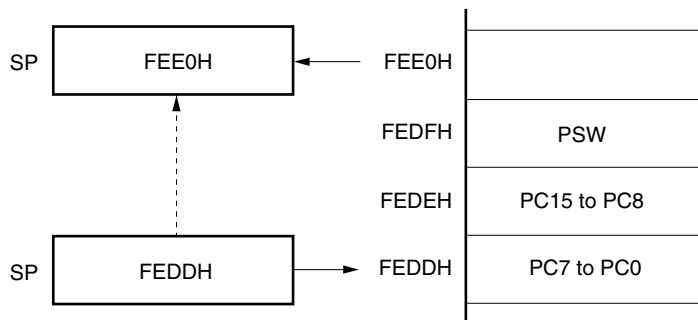

3.2.2 General-purpose registers

General-purpose registers are mapped at particular addresses (FEE0H to FEFFH) of the data memory. The general-purpose registers consists of 4 banks, each bank consisting of eight 8-bit registers (X, A, C, B, E, D, L, and H).

Each register can be used as an 8-bit register, and two 8-bit registers can also be used in a pair as a 16-bit register (AX, BC, DE, and HL).

These registers can be described in terms of function names (X, A, C, B, E, D, L, H, AX, BC, DE, and HL) and absolute names (R0 to R7 and RP0 to RP3).

Register banks to be used for instruction execution are set by the CPU control instruction (SEL RBn). Because of the 4-register bank configuration, an efficient program can be created by switching between a register for normal processing and a register for interrupts for each bank.

Figure 3-15. Configuration of General-Purpose Registers

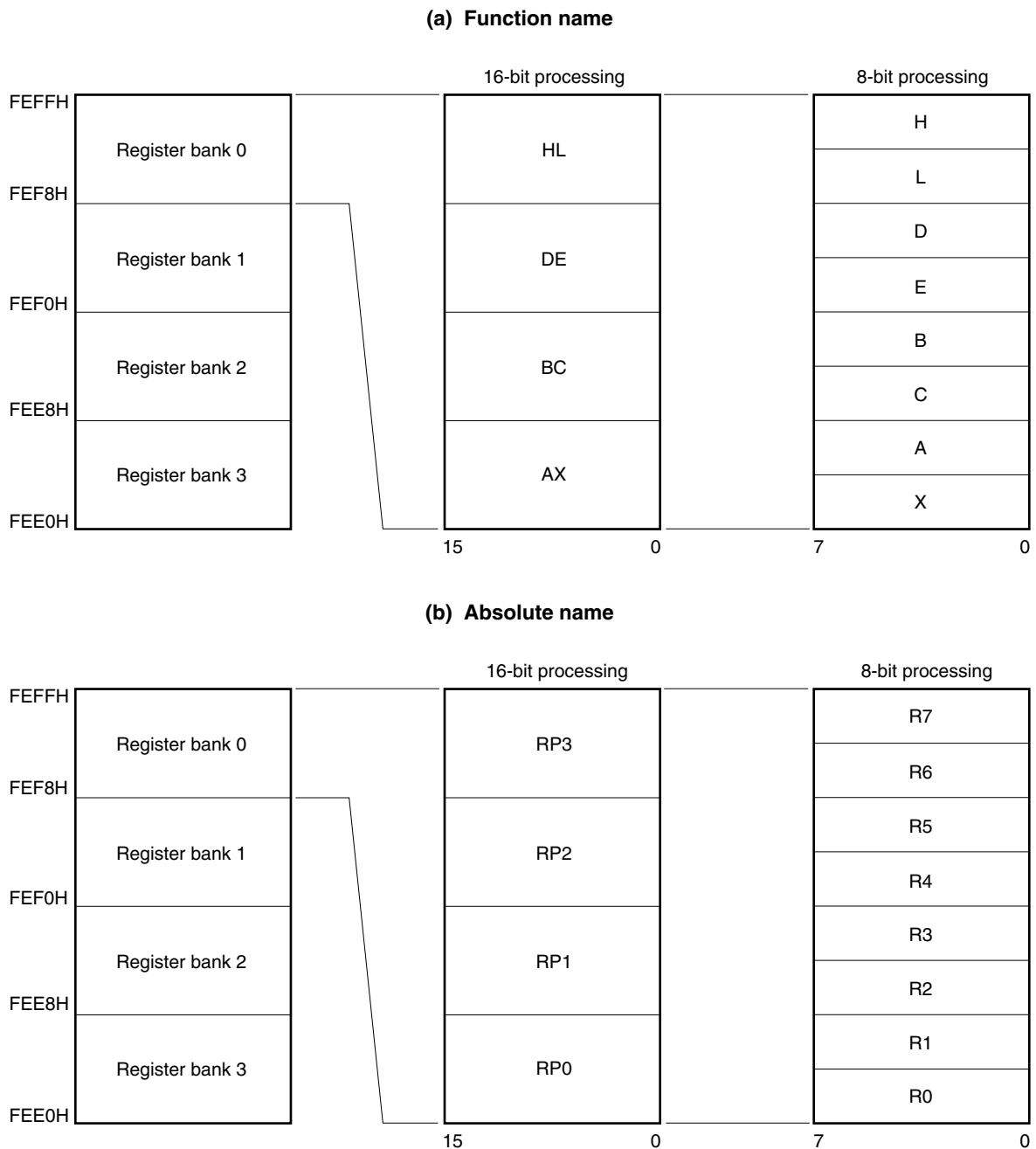

3.2.3 Special function registers (SFRs)

Unlike a general-purpose register, each special function register has a special function.

SFRs are allocated to the FF00H to FFFFH area.

Special function registers can be manipulated like general-purpose registers, using operation, transfer, and bit manipulation instructions. The manipulatable bit units, 1, 8, and 16, depend on the special function register type.

Each manipulation bit unit can be specified as follows.

- 1-bit manipulation

Describe the symbol reserved by the assembler for the 1-bit manipulation instruction operand (sfr.bit).

This manipulation can also be specified with an address.

- 8-bit manipulation

Describe the symbol reserved by the assembler for the 8-bit manipulation instruction operand (sfr).

This manipulation can also be specified with an address.

- 16-bit manipulation

Describe the symbol reserved by the assembler for the 16-bit manipulation instruction operand (sfrp).

When specifying an address, describe an even address.

Table 3-5 gives a list of the special function registers. The meanings of items in the table are as follows.

- Symbol

Symbol indicating the address of a special function register. It is a reserved word in the RA78K0, and is defined as an sfr variable using the #pragma sfr directive in the CC78K0. When using the RA78K0, ID78K0-QB, and SM+ for 78K0/KX2, symbols can be written as an instruction operand.

- R/W

Indicates whether the corresponding special function register can be read or written.

R/W: Read/write enable

R: Read only

W: Write only

- Manipulatable bit units

Indicates the manipulatable bit unit (1, 8, or 16). “–” indicates a bit unit for which manipulation is not possible.

- After reset

Indicates each register status upon reset signal generation.

Table 3-6. Special Function Register List (1/3)

Address	Special Function Register (SFR) Name	Symbol	R/W	Manipulatable Bit Unit			After Reset
				1 Bit	8 Bits	16 Bits	
FF00H	Port register 0	P0	R/W	√	√	–	00H
FF01H	Port register 1	P1	R/W	√	√	–	00H
FF02H	Port register 2	P2	R/W	√	√	–	00H
FF03H	Port register 3	P3	R/W	√	√	–	00H
FF06H	Port register 6	P6	R/W	√	√	–	00H
FF08H	10-bit A/D conversion result register	ADCR	R	–	–	√	0000H
FF09H	8-bit A/D conversion result register	ADCRH	R	–	√	–	00H
FF0AH	Receive buffer register 6	RXB6	R	–	√	–	FFH
FF0BH	Transmit buffer register 6	TXB6	R/W	–	√	–	FFH
FF0CH	Port register 12	P12	R/W	√	√	–	00H
FF0FH	Serial I/O shift register 10	SIO10	R	–	√	–	00H
FF10H	16-bit timer counter 00	TM00	R	–	–	√	0000H
FF11H							
FF12H	16-bit timer capture/compare register 000	CR000	R/W	–	–	√	0000H
FF13H							
FF14H	16-bit timer capture/compare register 010	CR010	R/W	–	–	√	0000H
FF15H							
FF16H	8-bit timer counter 50	TM50	R	–	√	–	00H
FF17H	8-bit timer compare register 50	CR50	R/W	–	√	–	00H
FF18H	8-bit timer H compare register 00	CMP00	R/W	–	√	–	00H
FF19H	8-bit timer H compare register 10	CMP10	R/W	–	√	–	00H
FF1AH	8-bit timer H compare register 01	CMP01	R/W	–	√	–	00H
FF1BH	8-bit timer H compare register 11	CMP11	R/W	–	√	–	00H
FF1FH	8-bit timer counter 51	TM51	R	–	√	–	00H
FF20H	Port mode register 0	PM0	R/W	√	√	–	FFH
FF21H	Port mode register 1	PM1	R/W	√	√	–	FFH
FF22H	Port mode register 2	PM2	R/W	√	√	–	FFH
FF23H	Port mode register 3	PM3	R/W	√	√	–	FFH
FF26H	Port mode register 6	PM6	R/W	√	√	–	FFH
FF28H	A/D converter mode register	ADM	R/W	√	√	–	00H
FF29H	Analog input channel specification register	ADS	R/W	√	√	–	00H
FF2CH	Port mode register 12	PM12	R/W	√	√	–	FFH
FF2FH	A/D port configuration register	ADPC	R/W	√	√	–	00H
FF30H	Pull-up resistor option register 0	PU0	R/W	√	√	–	00H
FF31H	Pull-up resistor option register 1	PU1	R/W	√	√	–	00H
FF33H	Pull-up resistor option register 3	PU3	R/W	√	√	–	00H
FF3CH	Pull-up resistor option register 12	PU12	R/W	√	√	–	00H
FF41H	8-bit timer compare register 51	CR51	R/W	–	√	–	00H
FF43H	8-bit timer mode control register 51	TMC51	R/W	√	√	–	00H
FF48H	External interrupt rising edge enable register	EGP	R/W	√	√	–	00H
FF49H	External interrupt falling edge enable register	EGN	R/W	√	√	–	00H

Table 3-6. Special Function Register List (2/3)

Address	Special Function Register (SFR) Name	Symbol	R/W	Manipulatable Bit Unit			After Reset
				1 Bit	8 Bits	16 Bits	
FF4FH	Input switch control register	ISC	R/W	√	√	–	00H
FF50H	Asynchronous serial interface operation mode register 6	ASIM6	R/W	√	√	–	01H
FF53H	Asynchronous serial interface reception error status register 6	ASIS6	R	–	√	–	00H
FF55H	Asynchronous serial interface transmission status register 6	ASIF6	R	–	√	–	00H
FF56H	Clock selection register 6	CKSR6	R/W	–	√	–	00H
FF57H	Baud rate generator control register 6	BRGC6	R/W	–	√	–	FFH
FF58H	Asynchronous serial interface control register 6	ASICL6	R/W	√	√	–	16H
FF69H	8-bit timer H mode register 0	TMHMD0	R/W	√	√	–	00H
FF6AH	Timer clock selection register 50	TCL50	R/W	√	√	–	00H
FF6BH	8-bit timer mode control register 50	TMC50	R/W	√	√	–	00H
FF6CH	8-bit timer H mode register 1	TMHMD1	R/W	√	√	–	00H
FF6DH	8-bit timer H carrier control register 1	TMCYC1	R/W	√	√	–	00H
FF70H	Asynchronous serial interface operation mode register 0	ASIM0	R/W	√	√	–	01H
FF71H	Baud rate generator control register 0	BRGC0	R/W	–	√	–	1FH
FF72H	Receive buffer register 0	RXB0	R	–	√	–	FFH
FF73H	Asynchronous serial interface reception error status register 0	ASIS0	R	–	√	–	00H
FF74H	Transmit shift register 0	TXS0	W	–	√	–	FFH
FF80H	Serial operation mode register 10	CSIM10	R/W	√	√	–	00H
FF81H	Serial clock selection register 10	CSIC10	R/W	√	√	–	00H
FF84H	Transmit buffer register 10	SOTB10	R/W	–	√	–	00H
FF8CH	Timer clock selection register 51	TCL51	R/W	√	√	–	00H
FF99H	Watchdog timer enable register	WDTE	R/W	–	√	–	1AH/9AH Note 1
FF9FH	Clock operation mode select register	OSCCTL	R/W	√	√	–	00H
FFA0H	Internal oscillation mode register	RCM	R/W	√	√	–	80H ^{Note 2}
FFA1H	Main clock mode register	MCM	R/W	√	√	–	00H
FFA2H	Main OSC control register	MOC	R/W	√	√	–	80H
FFA3H	Oscillation stabilization time counter status register	OSTC	R	√	√	–	00H
FFA4H	Oscillation stabilization time select register	OSTS	R/W	–	√	–	05H

- Notes 1.** The reset value of WDTE is determined by setting of option byte.
- 2.** The value of this register is 00H immediately after a reset release but automatically changes to 80H after oscillation accuracy stabilization of internal high-speed oscillator has been waited.

Table 3-6. Special Function Register List (3/3)

Address	Special Function Register (SFR) Name	Symbol		R/W	Manipulatable Bit Unit			After Reset
					1 Bit	8 Bits	16 Bits	
FFA5H	IIC shift register 0	IIC0		R/W	–	√	–	00H
FFA6H	IIC control register 0	IICC0		R/W	√	√	–	00H
FFA7H	Slave address register 0	SVA0		R/W	–	√	–	00H
FFA8H	IIC clock selection register 0	IICCL0		R/W	√	√	–	00H
FFA9H	IIC function expansion register 0	IICX0		R/W	√	√	–	00H
FFAAH	IIC status register 0	IICS0		R	√	√	–	00H
FFABH	IIC flag register 0	IICF0		R/W	√	√	–	00H
FFACH	Reset control flag register	RESF		R	–	√	–	00H ^{Note 1}
FFBAH	16-bit timer mode control register 00	TMC00		R/W	√	√	–	00H
FFBBH	Prescaler mode register 00	PRM00		R/W	√	√	–	00H
FFBCH	Capture/compare control register 00	CRC00		R/W	√	√	–	00H
FFBDH	16-bit timer output control register 00	TOC00		R/W	√	√	–	00H
FFBEH	Low-voltage detection register	LVIM		R/W	√	√	–	00H ^{Note 2}
FFBFH	Low-voltage detection level selection register	LVIS		R/W	√	√	–	00H ^{Note 2}
FFE0H	Interrupt request flag register 0L	IF0	IF0L	R/W	√	√	√	00H
FFE1H	Interrupt request flag register 0H		IF0H	R/W	√	√		00H
FFE2H	Interrupt request flag register 1L	IF1	IF1L	R/W	√	√	√	00H
FFE3H	Interrupt request flag register 1H		IF1H	R/W	√	√		00H
FFE4H	Interrupt mask flag register 0L	MK0	MK0L	R/W	√	√	√	FFH
FFE5H	Interrupt mask flag register 0H		MK0H	R/W	√	√		FFH
FFE6H	Interrupt mask flag register 1L	MK1	MK1L	R/W	√	√	√	FFH
FFE7H	Interrupt mask flag register 1H		MK1H	R/W	√	√		FFH
FFE8H	Priority specification flag register 0L	PR0	PR0L	R/W	√	√	√	FFH
FFE9H	Priority specification flag register 0H		PR0H	R/W	√	√		FFH
FFEAH	Priority specification flag register 1L	PR1	PR1L	R/W	√	√	√	FFH
FFEBH	Priority specification flag register 1H		PR1H	R/W	√	√		FFH
FFF0H	Internal memory size switching register ^{Note 3}	IMS		R/W	–	√	–	CFH
FFFBH	Processor clock control register	PCC		R/W	√	√	–	01H

- Notes**
- The reset value of RESF varies depending on the reset source.
 - The reset values of LVIM and LVIS vary depending on the reset source.
 - Regardless of the internal memory capacity, the initial values of the internal memory size switching register (IMS) of all products in the 78K0/KB2 are fixed (IMS = CFH). Therefore, set the value corresponding to each product as indicated below.

Flash Memory Version (78K0/KB2)	IMS	ROM Capacity	Internal High-Speed RAM Capacity
μPD78F0500	42H	8 KB	512 bytes
μPD78F0501	04H	16 KB	768 bytes
μPD78F0502	C6H	24 KB	1 KB
μPD78F0503, 78F0503D	C8H	32 KB	

3.3 Instruction Address Addressing

An instruction address is determined by contents of the program counter (PC), and is normally incremented (+1 for each byte) automatically according to the number of bytes of an instruction to be fetched each time another instruction is executed. When a branch instruction is executed, the branch destination information is set to PC and branched by the following addressing (for details of instructions, refer to the **78K/0 Series Instructions User's Manual (U12326E)**).

3.3.1 Relative addressing

[Function]

The value obtained by adding 8-bit immediate data (displacement value: *jdisp8*) of an instruction code to the start address of the following instruction is transferred to the program counter (PC) and branched. The displacement value is treated as signed two's complement data (−128 to +127) and bit 7 becomes a sign bit.

In other words, relative addressing consists of relative branching from the start address of the following instruction to the −128 to +127 range.

This function is carried out when the BR \$addr16 instruction or a conditional branch instruction is executed.

[Illustration]

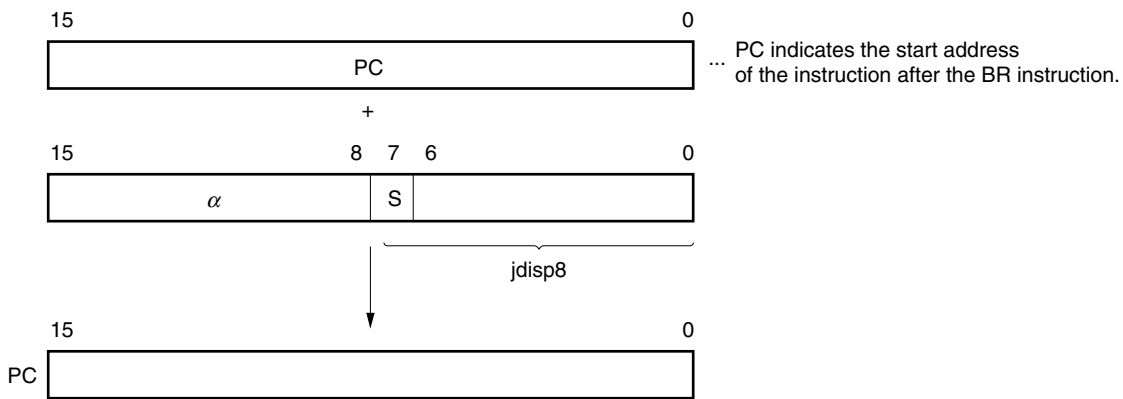

When S = 0, all bits of α are 0.
 When S = 1, all bits of α are 1.

3.3.2 Immediate addressing

[Function]

Immediate data in the instruction word is transferred to the program counter (PC) and branched.
 This function is carried out when the CALL !addr16 or BR !addr16 or CALLF !addr11 instruction is executed.
 CALL !addr16 and BR !addr16 instructions can be branched to the entire memory space.
 The CALLF !addr11 instruction is branched to the 0800H to 0FFFH area.

[Illustration]

In the case of CALL !addr16 and BR !addr16 instructions

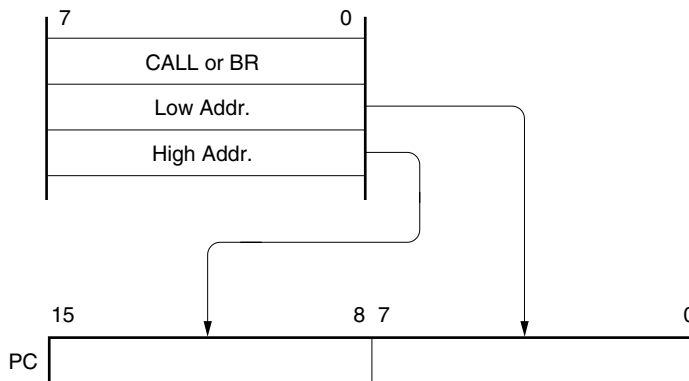

In the case of CALLF !addr11 instruction

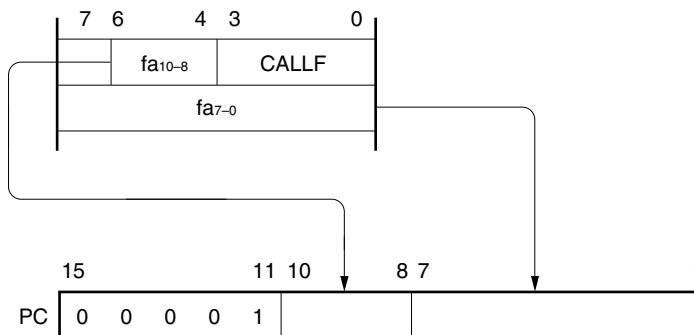

3.3.3 Table indirect addressing

[Function]

Table contents (branch destination address) of the particular location to be addressed by bits 1 to 5 of the immediate data of an operation code are transferred to the program counter (PC) and branched.

This function is carried out when the CALLT [addr5] instruction is executed.

This instruction references the address stored in the memory table from 40H to 7FH, and allows branching to the entire memory space.

[Illustration]

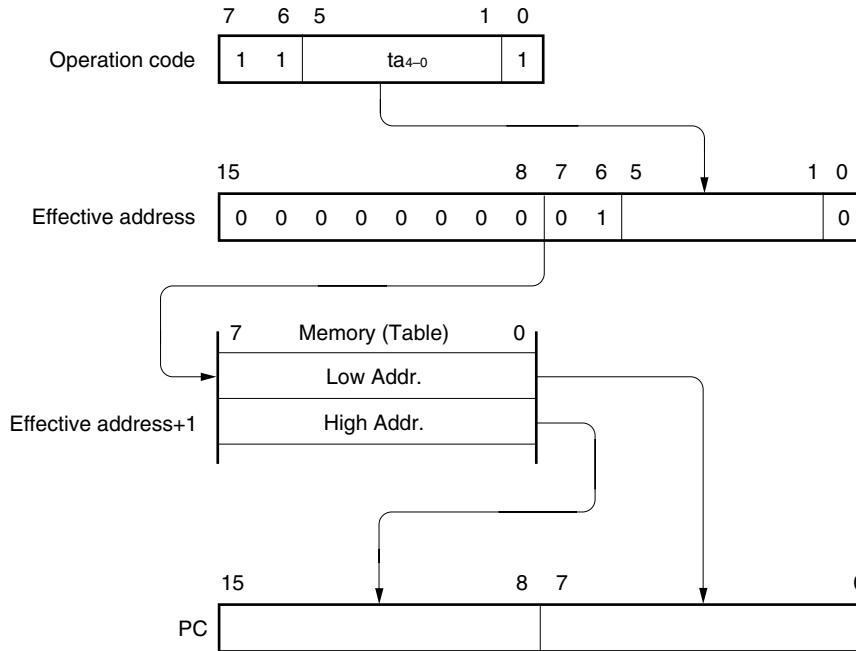

3.3.4 Register addressing

[Function]

Register pair (AX) contents to be specified with an instruction word are transferred to the program counter (PC) and branched.

This function is carried out when the BR AX instruction is executed.

[Illustration]

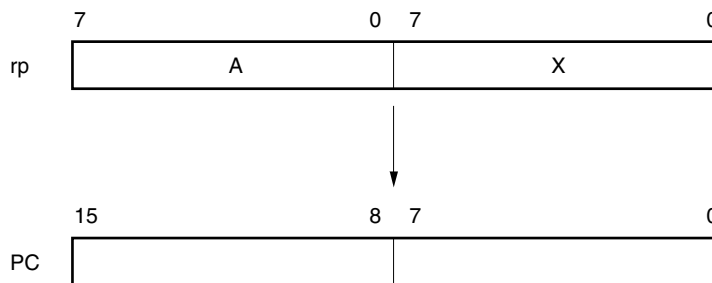

3.4 Operand Address Addressing

The following methods are available to specify the register and memory (addressing) to undergo manipulation during instruction execution.

3.4.1 Implied addressing

[Function]

The register that functions as an accumulator (A and AX) among the general-purpose registers is automatically (implicitly) addressed.

Of the 78K0/KB2 instruction words, the following instructions employ implied addressing.

Instruction	Register to Be Specified by Implied Addressing
MULU	A register for multiplicand and AX register for product storage
DIVUW	AX register for dividend and quotient storage
ADJBA/ADJBS	A register for storage of numeric values that become decimal correction targets
ROR4/ROL4	A register for storage of digit data that undergoes digit rotation

[Operand format]

Because implied addressing can be automatically determined with an instruction, no particular operand format is necessary.

[Description example]

In the case of MULU X

With an 8-bit × 8-bit multiply instruction, the product of A register and X register is stored in AX. In this example, the A and AX registers are specified by implied addressing.

3.4.2 Register addressing

[Function]

The general-purpose register to be specified is accessed as an operand with the register bank select flags (RBS0 to RBS1) and the register specify codes of an operation code.

Register addressing is carried out when an instruction with the following operand format is executed. When an 8-bit register is specified, one of the eight registers is specified with 3 bits in the operation code.

[Operand format]

Identifier	Description
r	X, A, C, B, E, D, L, H
rp	AX, BC, DE, HL

'r' and 'rp' can be described by absolute names (R0 to R7 and RP0 to RP3) as well as function names (X, A, C, B, E, D, L, H, AX, BC, DE, and HL).

[Description example]

MOV A, C; when selecting C register as r

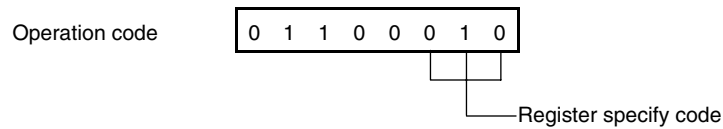

INCW DE; when selecting DE register pair as rp

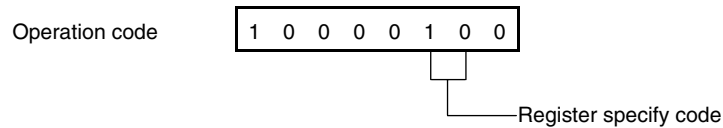

3.4.3 Direct addressing

[Function]

The memory to be manipulated is directly addressed with immediate data in an instruction word becoming an operand address.

This addressing can be carried out for all of the memory spaces.

[Operand format]

Identifier	Description
addr16	Label or 16-bit immediate data

[Description example]

MOV A, !0FE00H; when setting !addr16 to FE00H

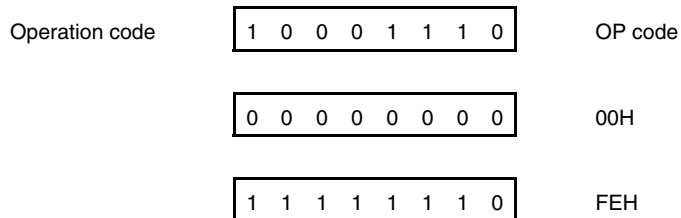

[Illustration]

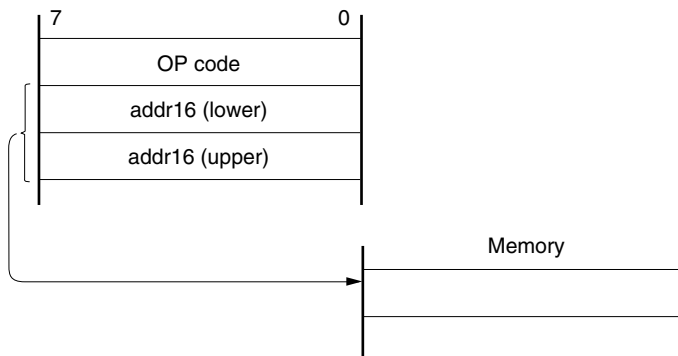

3.4.4 Short direct addressing

[Function]

The memory to be manipulated in the fixed space is directly addressed with 8-bit data in an instruction word. This addressing is applied to the 256-byte space FE20H to FF1FH. Internal high-speed RAM and special function registers (SFRs) are mapped at FE20H to FEFFH and FF00H to FF1FH, respectively. The SFR area (FF00H to FF1FH) where short direct addressing is applied is a part of the overall SFR area. Ports that are frequently accessed in a program and compare and capture registers of the timer/event counter are mapped in this area, allowing SFRs to be manipulated with a small number of bytes and clocks. When 8-bit immediate data is at 20H to FFH, bit 8 of an effective address is set to 0. When it is at 00H to 1FH, bit 8 is set to 1. See the [Illustration] shown below.

[Operand format]

Identifier	Description
saddr	Immediate data that indicate label or FE20H to FF1FH
saddrp	Immediate data that indicate label or FE20H to FF1FH (even address only)

[Description example]

```

LB1 EQU 0FE30H ; Defines FE30H by LB1.
:
MOV LB1, A ; When LB1 indicates FE30H of the saddr area and the value of register A is transferred to that address
    
```

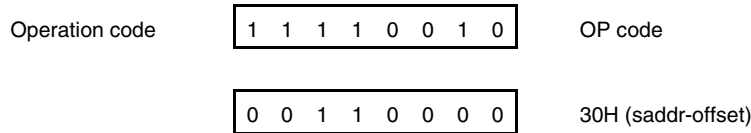

[Illustration]

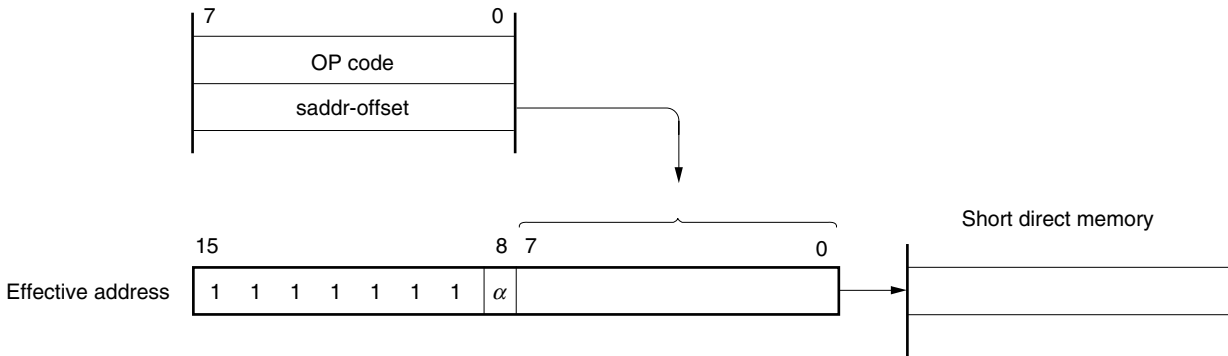

When 8-bit immediate data is 20H to FFH, $\alpha = 0$
 When 8-bit immediate data is 00H to 1FH, $\alpha = 1$

3.4.5 Special function register (SFR) addressing

[Function]

A memory-mapped special function register (SFR) is addressed with 8-bit immediate data in an instruction word. This addressing is applied to the 240-byte spaces FF00H to FFCFH and FFE0H to FFFFH. However, the SFRs mapped at FF00H to FF1FH can be accessed with short direct addressing.

[Operand format]

Identifier	Description
sfr	Special function register name
sfrp	16-bit manipulatable special function register name (even address only)

[Description example]

MOV PM0, A; when selecting PM0 (FF20H) as sfr

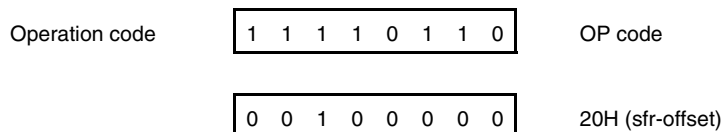

[Illustration]

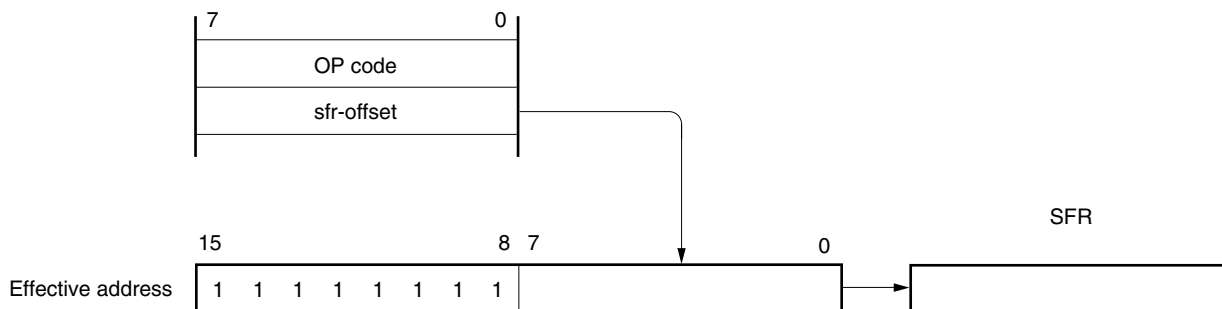

3.4.6 Register indirect addressing

[Function]

Register pair contents specified by a register pair specify code in an instruction word and by a register bank select flag (RBS0 and RBS1) serve as an operand address for addressing the memory.

This addressing can be carried out for all of the memory spaces.

[Operand format]

Identifier	Description
-	[DE], [HL]

[Description example]

MOV A, [DE]; when selecting [DE] as register pair

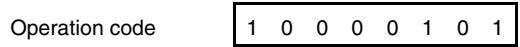

[Illustration]

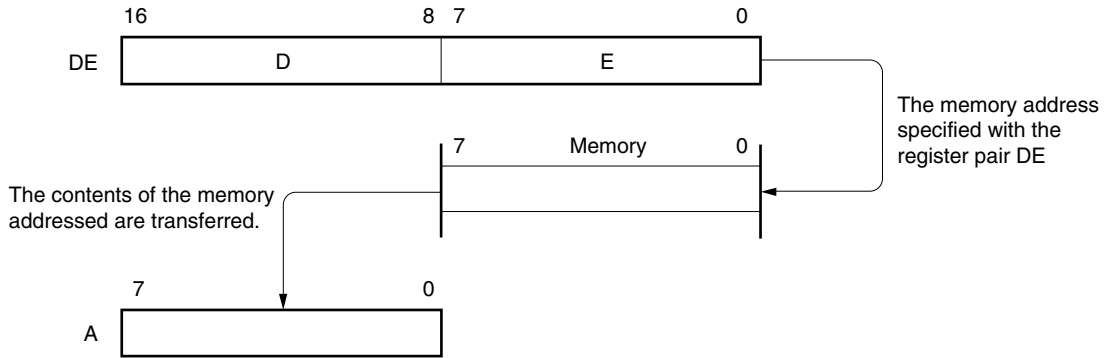

3.4.7 Based addressing

[Function]

8-bit immediate data is added as offset data to the contents of the base register, that is, the HL register pair in the register bank specified by the register bank select flag (RBS0 and RBS1), and the sum is used to address the memory. Addition is performed by expanding the offset data as a positive number to 16 bits. A carry from the 16th bit is ignored.

This addressing can be carried out for all of the memory spaces.

[Operand format]

Identifier	Description
-	[HL + byte]

[Description example]

MOV A, [HL + 10H]; when setting byte to 10H

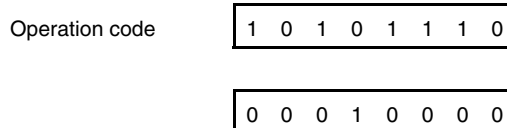

[Illustration]

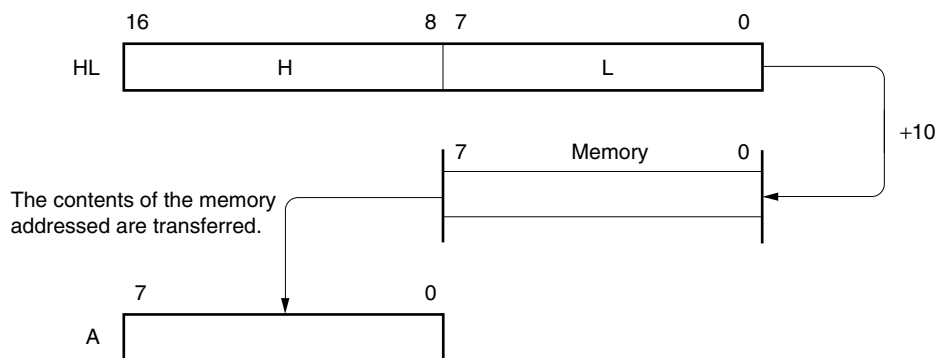

3.4.8 Based indexed addressing

[Function]

The B or C register contents specified in an instruction word are added to the contents of the base register, that is, the HL register pair in the register bank specified by the register bank select flag (RBS0 and RBS1), and the sum is used to address the memory. Addition is performed by expanding the B or C register contents as a positive number to 16 bits. A carry from the 16th bit is ignored.

This addressing can be carried out for all of the memory spaces.

[Operand format]

Identifier	Description
-	[HL + B], [HL + C]

[Description example]

MOV A, [HL + B]; when selecting B register

Operation code

1	0	1	0	1	0	1	1
---	---	---	---	---	---	---	---

[Illustration]

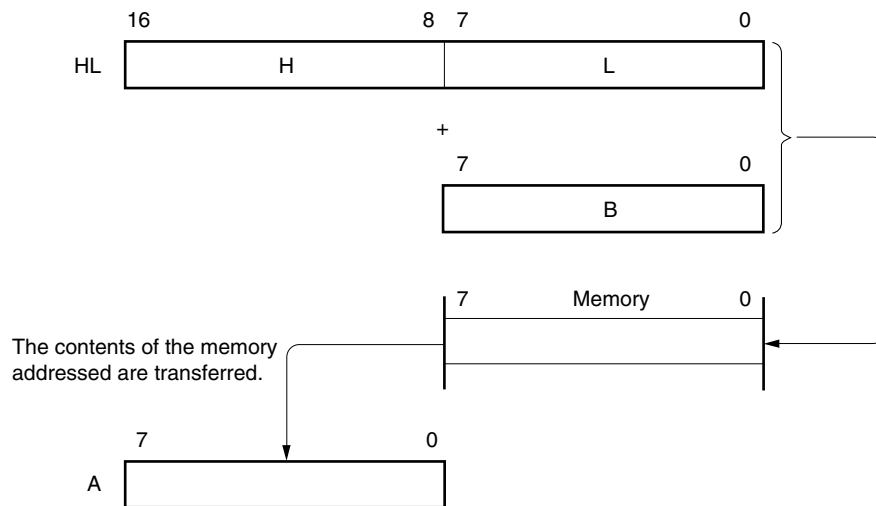

3.4.9 Stack addressing

[Function]

The stack area is indirectly addressed with the stack pointer (SP) contents.

This addressing method is automatically employed when the PUSH, POP, subroutine call and return instructions are executed or the register is saved/reset upon generation of an interrupt request.

With stack addressing, only the internal high-speed RAM area can be accessed.

[Description example]

PUSH DE; when saving DE register

Operation code

1	0	1	1	0	1	0	1
---	---	---	---	---	---	---	---

[Illustration]

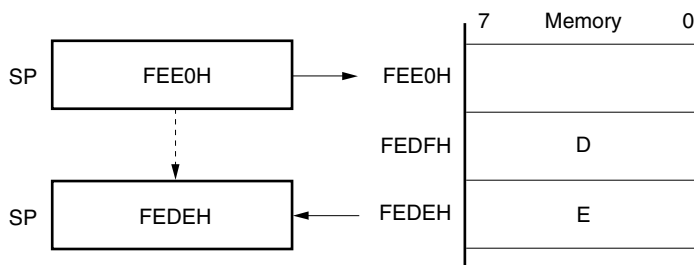

CHAPTER 4 PORT FUNCTIONS

4.1 Port Functions

There are two types of pin I/O buffer power supplies in the 30-pin plastic SSOP (MC-5A4 and MC-CAB types): AV_{REF} , and V_{DD} , and three types of pin I/O buffer power supplies in the 36-pin plastic FLGA (FC-AA3 type): AV_{REF} , EV_{DD} , and V_{DD} . The relationship between these power supplies and the pins is shown below.

Table 4-1. Pin I/O Buffer Power Supplies

Power Supply	Corresponding Pins	
	30-pin SSOP	36-pin FLGA
AV_{REF}	P20 to P23	P20 to P23
EV_{DD}	–	Port pins other than P20 to P23, P121, and P122
V_{DD}	Pins other than P20 to P23	<ul style="list-style-type: none"> • P121 and P122 • Pins other than port

78K0/KB2 products are provided with the ports shown in Figure 4-1, which enable variety of control operations. The functions of each port are shown in Table 4-2.

In addition to the function as digital I/O ports, these ports have several alternate functions. For details of the alternate functions, see **CHAPTER 2 PIN FUNCTIONS**.

Figure 4-1. Port Types

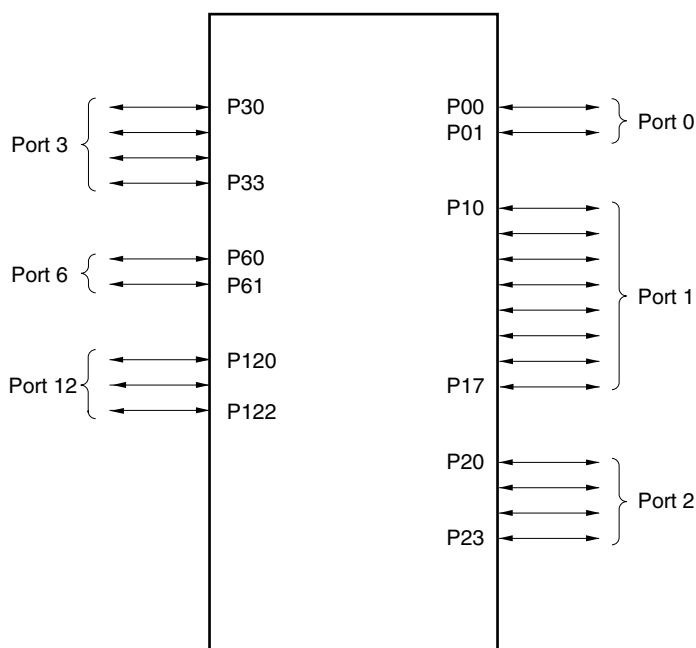

Table 4-2. Port Functions

Function Name	I/O	Function	After Reset	Alternate Function
P00	I/O	Port 0. 2-bit I/O port. Input/output can be specified in 1-bit units. Use of an on-chip pull-up resistor can be specified by a software setting.	Input port	TI000
P01				TI010/TO00
P10	I/O	Port 1. 8-bit I/O port. Input/output can be specified in 1-bit units. Use of an on-chip pull-up resistor can be specified by a software setting.	Input port	SCK10/TxD0
P11				S110/RxD0
P12				SO10
P13				TxD6
P14				RxD6
P15				TOH0
P16				TOH1/INTP5
P17				TI50/TO50
P20 to P23	I/O	Port 2. 4-bit I/O port. Input/output can be specified in 1-bit units.	Analog input	ANI0 to ANI3
P30	I/O	Port 3. 4-bit I/O port. Input/output can be specified in 1-bit units. Use of an on-chip pull-up resistor can be specified by a software setting.	Input port	INTP1
P31				INTP2/OCD1A ^{Note}
P32				INTP3/OCD1B ^{Note}
P33				TI51/TO51/INTP4
P60	I/O	Port 6. 2-bit I/O port. Output is N-ch open-drain output (6 V tolerance). Input/output can be specified in 1-bit units.	Input port	SCL0
P61				SDA0
P120	I/O	Port 12. 3-bit I/O port. Input/output can be specified in 1-bit units. Only for P120, use of an on-chip pull-up resistor can be specified by a software setting.	Input port	INTP0/EXLVI
P121				X1/OCD0A ^{Note}
P122				X2/EXCLK/OCD0B ^{Note}

Note μ PD78F0503D only

4.2 Port Configuration

Ports include the following hardware.

Table 4-3. Port Configuration

Item	Configuration
Control registers	Port mode register (PM0 to PM3, PM6, PM12) Port register (P0 to P3, P6, P12) Pull-up resistor option register (PU0, PU1, PU3, PU12) A/D port configuration register (ADPC)
Port	Total: 23 (CMOS I/O: 21, N-ch open drain I/O: 2)
Pull-up resistor	Total: 15

4.2.1 Port 0

Port 0 is a 2-bit I/O port with an output latch. Port 0 can be set to the input mode or output mode in 1-bit units using port mode register 0 (PM0). When the P00, P01 pins are used as an input port, use of an on-chip pull-up resistor can be specified in 1-bit units by pull-up resistor option register 0 (PU0).

This port can also be used for timer I/O.

Reset signal generation sets port 0 to input mode.

Figures 4-2 and 4-3 show block diagrams of port 0.

Figure 4-2. Block Diagram of P00

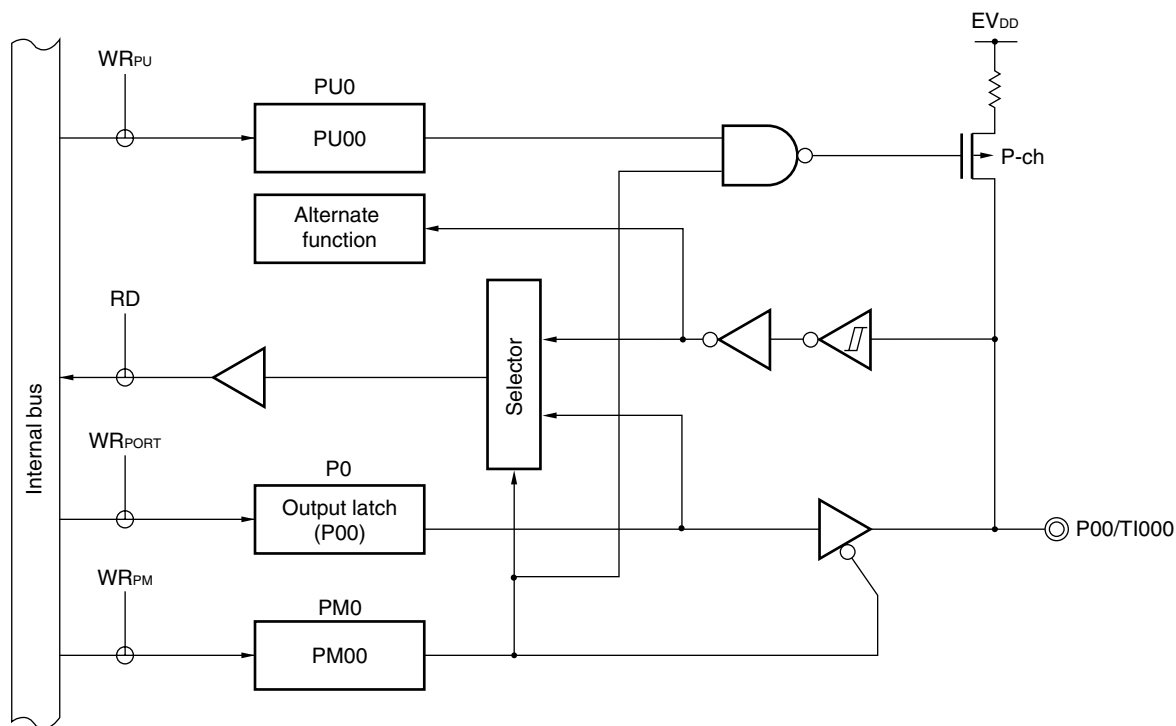

- P0: Port register 0
- PU0: Pull-up resistor option register 0
- PM0: Port mode register 0
- RD: Read signal
- WR_{xx}: Write signal

Remark There are not the EV_{DD} pin and the EV_{SS} pin in the 30-pin plastic SSOP (MC-5A4 and MC-CAB types). Therefore, transpose EV_{DD} and EV_{SS} to V_{DD} and V_{SS}, respectively, in the case of the 30-pin plastic SSOP (MC-5A4 and MC-CAB types).

Figure 4-3. Block Diagram of P01

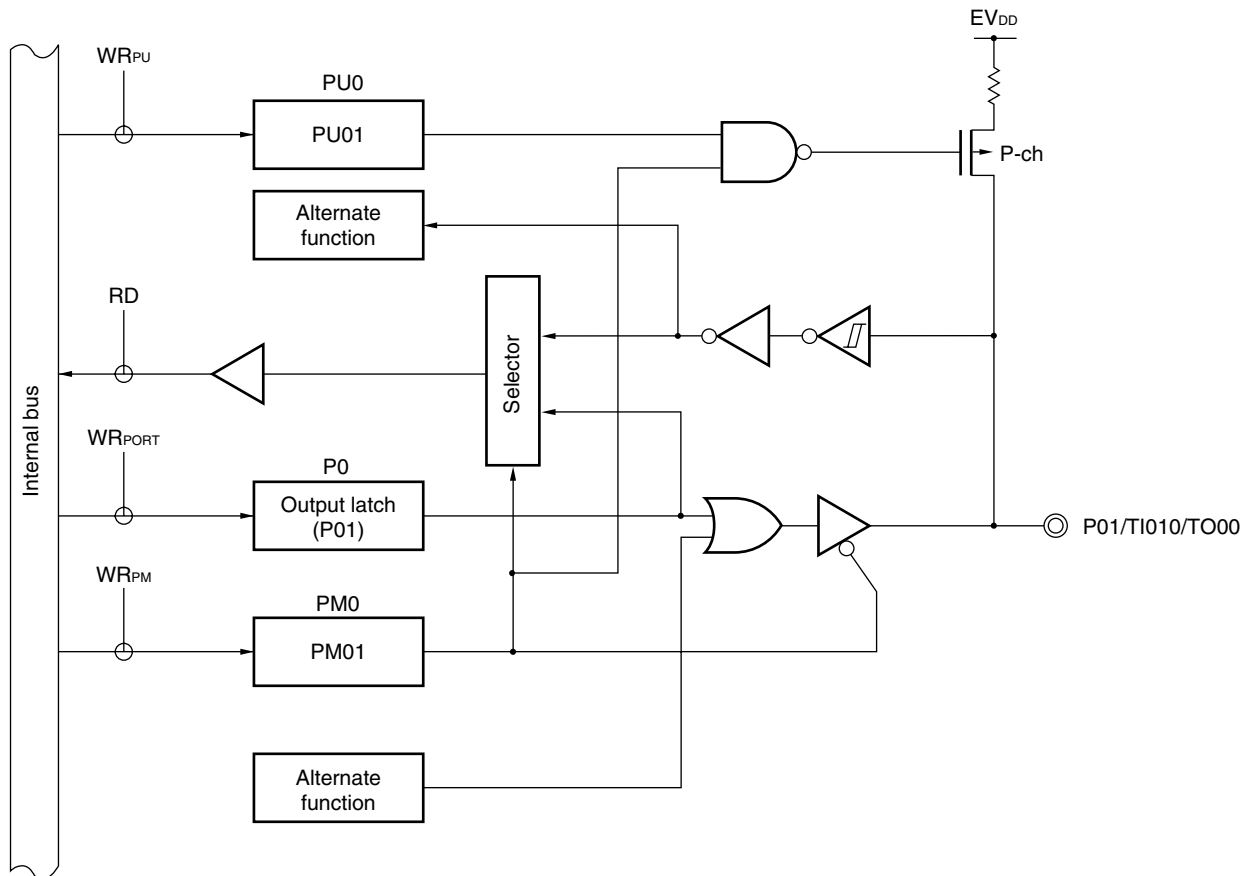

P0: Port register 0
 PU0: Pull-up resistor option register 0
 PM0: Port mode register 0
 RD: Read signal
 WR_{xx} : Write signal

Remark There are not the EV_{DD} pin and the EV_{SS} pin in the 30-pin plastic SSOP (MC-5A4 and MC-CAB types). Therefore, transpose EV_{DD} and EV_{SS} to V_{DD} and V_{SS} , respectively, in the case of the 30-pin plastic SSOP (MC-5A4 and MC-CAB types).

4.2.2 Port 1

Port 1 is an 8-bit I/O port with an output latch. Port 1 can be set to the input mode or output mode in 1-bit units using port mode register 1 (PM1). When the P10 to P17 pins are used as an input port, use of an on-chip pull-up resistor can be specified in 1-bit units by pull-up resistor option register 1 (PU1).

This port can also be used for external interrupt request input, serial interface data I/O, clock I/O, and timer I/O. Reset signal generation sets port 1 to input mode. Figures 4-4 to 4-8 show block diagrams of port 1.

Caution To use P10/ $\overline{\text{SCK10}}$ /TxD0 and P12/SO10 as general-purpose ports, set serial operation mode register 10 (CSIM10) and serial clock selection register 10 (CSIC10) to the default status (00H).

Figur 4-4. Block Diagram of P10

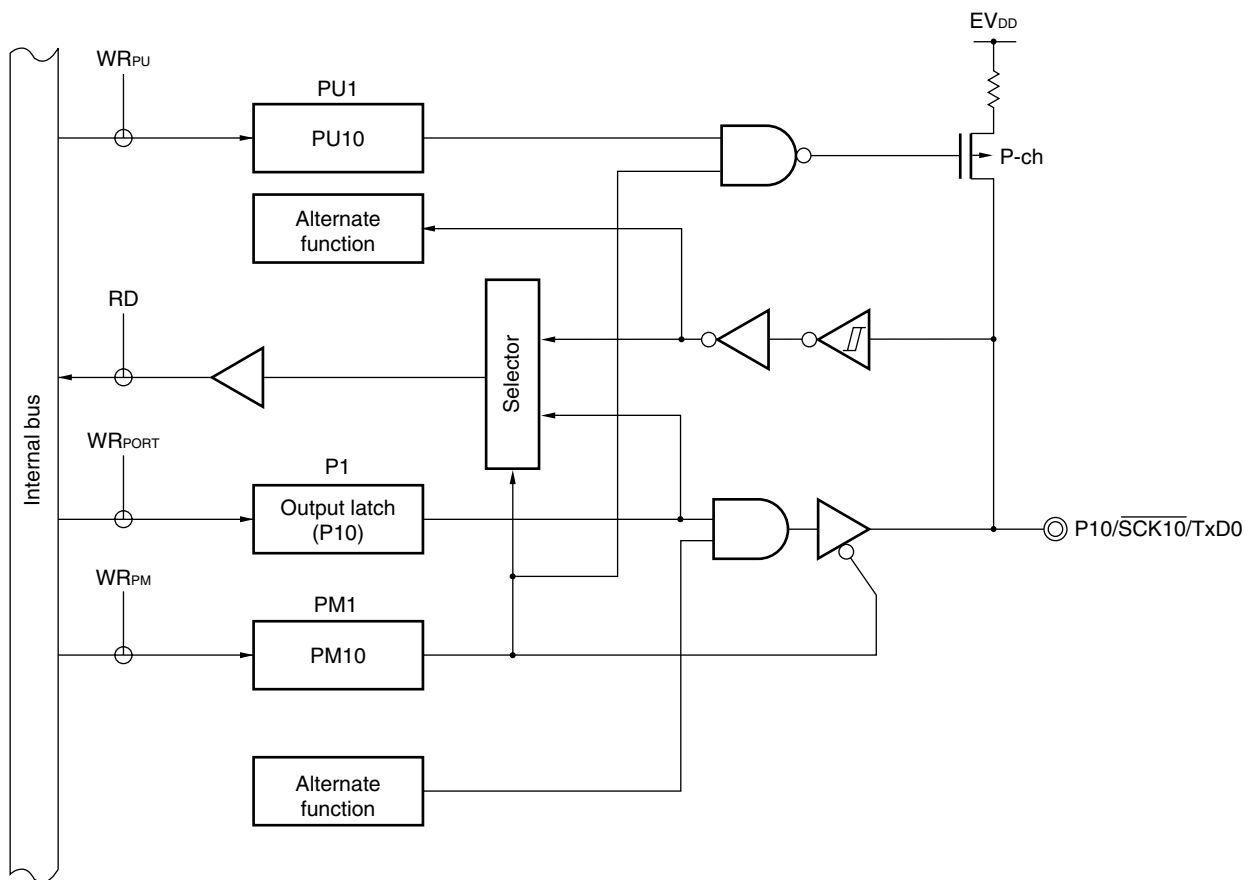

- P1: Port register 1
- PU1: Pull-up resistor option register 1
- PM1: Port mode register 1
- RD: Read signal
- WR_{xx}: Write signal

Remark There are not the EV_{DD} pin and the EV_{SS} pin in the 30-pin plastic SSOP (MC-5A4 and MC-CAB types). Therefore, transpose EV_{DD} and EV_{SS} to V_{DD} and V_{SS}, respectively, in the case of the 30-pin plastic SSOP (MC-5A4 and MC-CAB types).

Figure 4-5. Block Diagram of P11 and P14

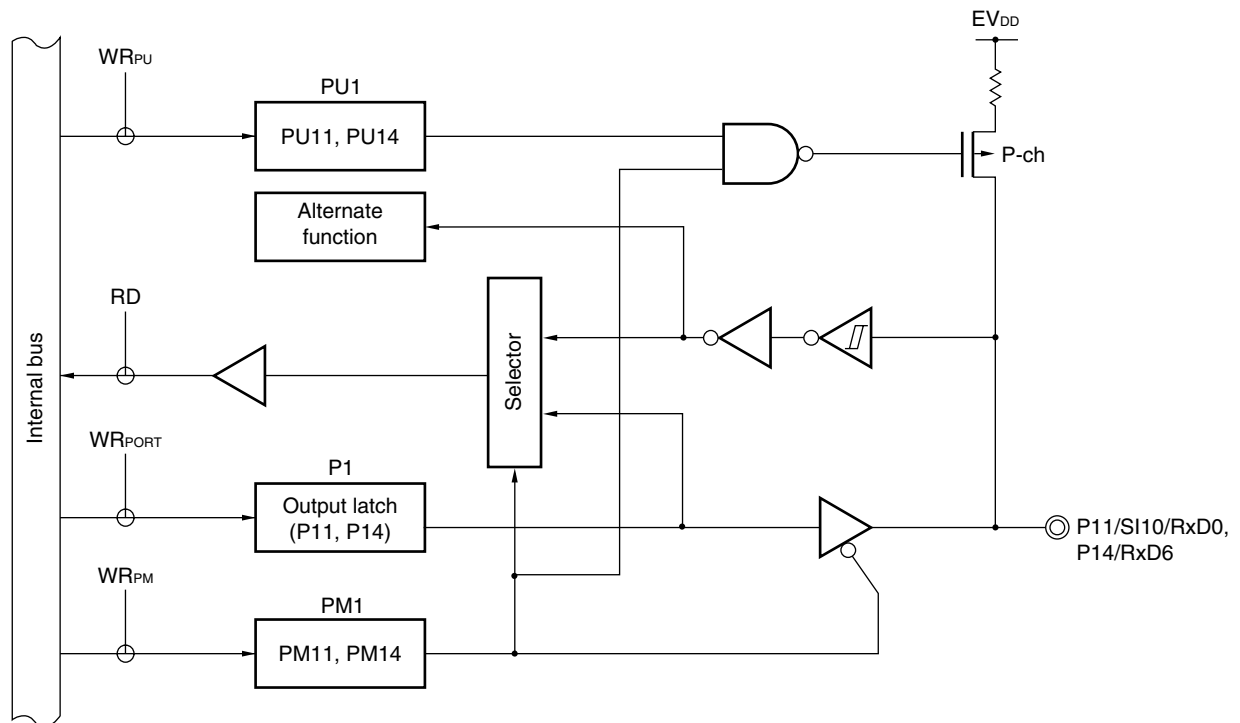

- P1: Port register 1
 PU1: Pull-up resistor option register 1
 PM1: Port mode register 1
 RD: Read signal
 WR_{xx} : Write signal

Remark There are not the EV_{DD} pin and the EV_{SS} pin in the 30-pin plastic SSOP (MC-5A4 and MC-CAB types). Therefore, transpose EV_{DD} and EV_{SS} to V_{DD} and V_{SS} , respectively, in the case of the 30-pin plastic SSOP (MC-5A4 and MC-CAB types).

Figure 4-6. Block Diagram of P12 and P15

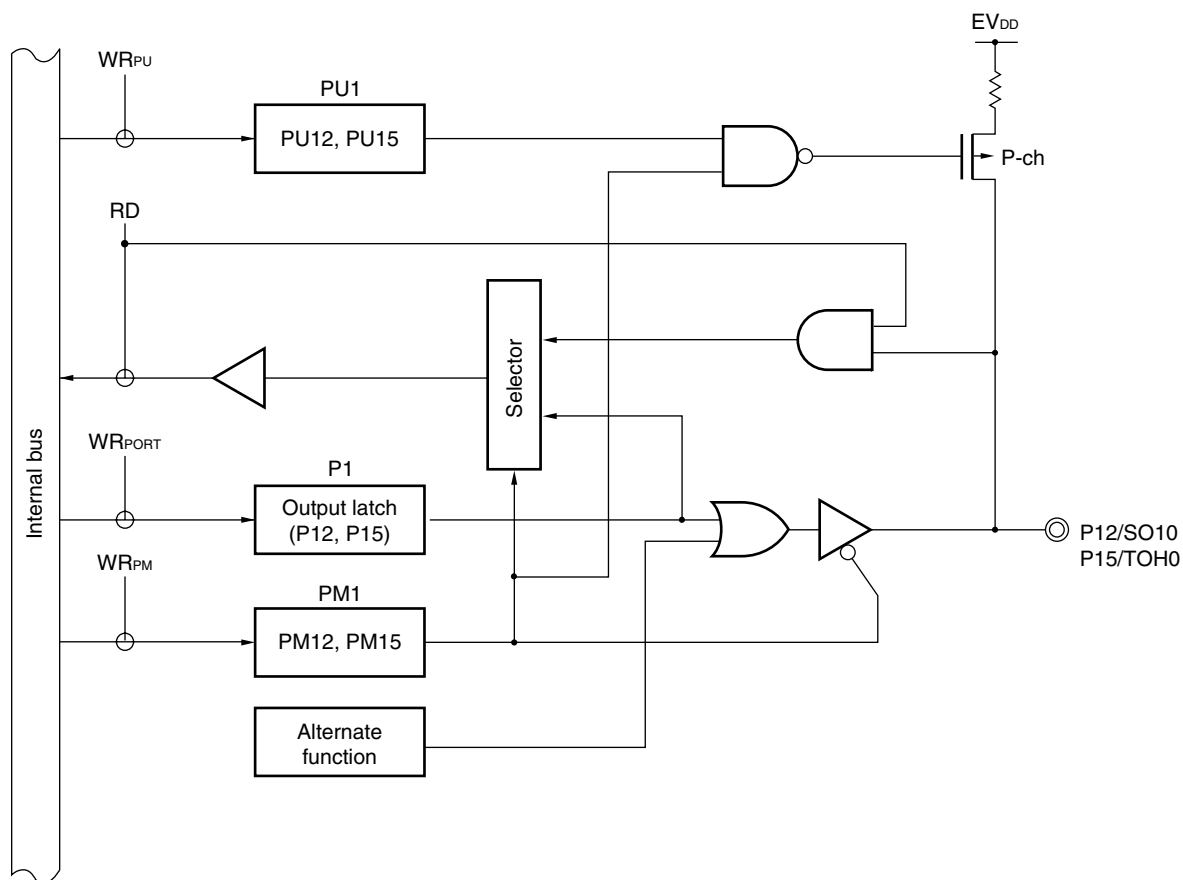

- P1: Port register 1
- PU1: Pull-up resistor option register 1
- PM1: Port mode register 1
- RD: Read signal
- WR_{xx}: Write signal

Remark There are not the EV_{DD} pin and the EV_{SS} pin in the 30-pin plastic SSOP (MC-5A4 and MC-CAB types). Therefore, transpose EV_{DD} and EV_{SS} to V_{DD} and V_{SS}, respectively, in the case of the 30-pin plastic SSOP (MC-5A4 and MC-CAB types).

Figure 4-7. Block Diagram of P13

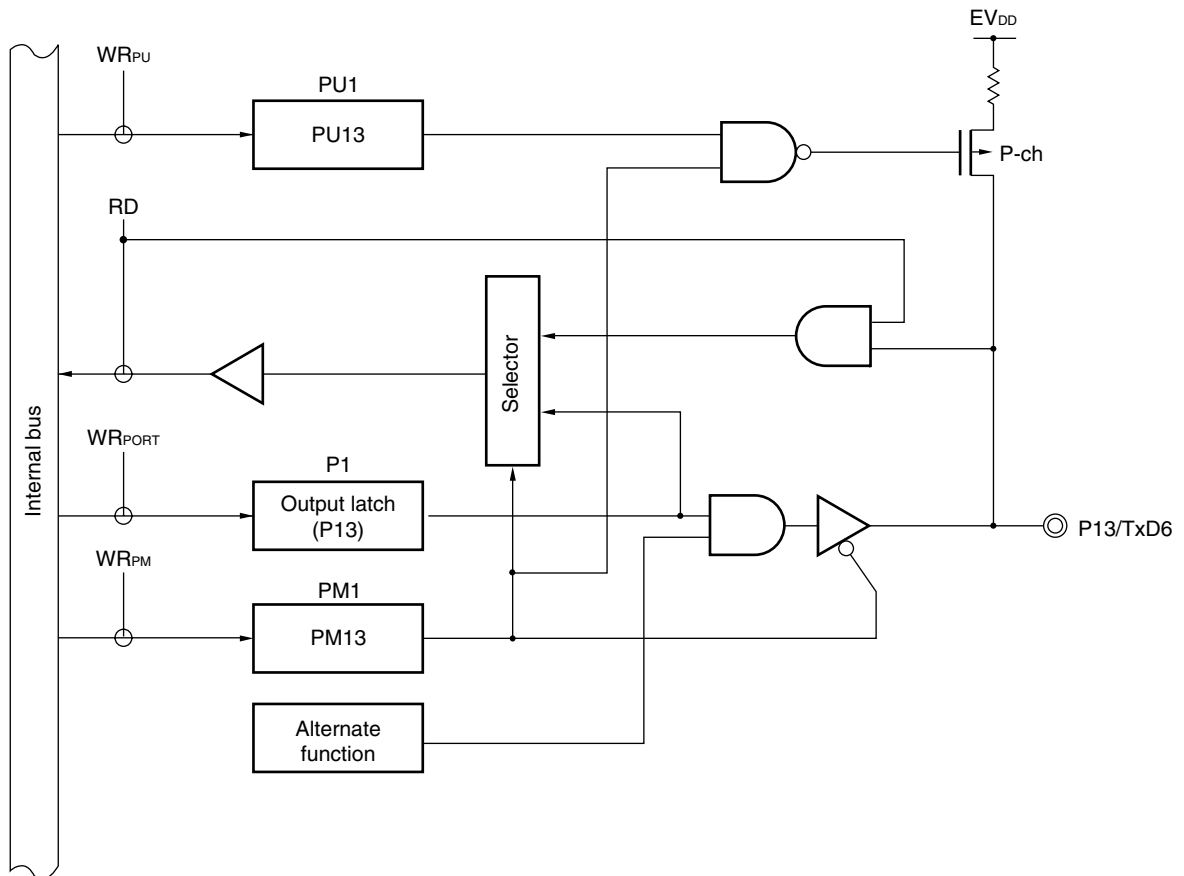

- P1: Port register 1
- PU1: Pull-up resistor option register 1
- PM1: Port mode register 1
- RD: Read signal
- WR_{xx} : Write signal

Remark There are not the EV_{DD} pin and the EV_{SS} pin in the 30-pin plastic SSOP (MC-5A4 and MC-CAB types). Therefore, transpose EV_{DD} and EV_{SS} to V_{DD} and V_{SS} , respectively, in the case of the 30-pin plastic SSOP (MC-5A4 and MC-CAB types).

Figure 4-8. Block Diagram of P16 and P17

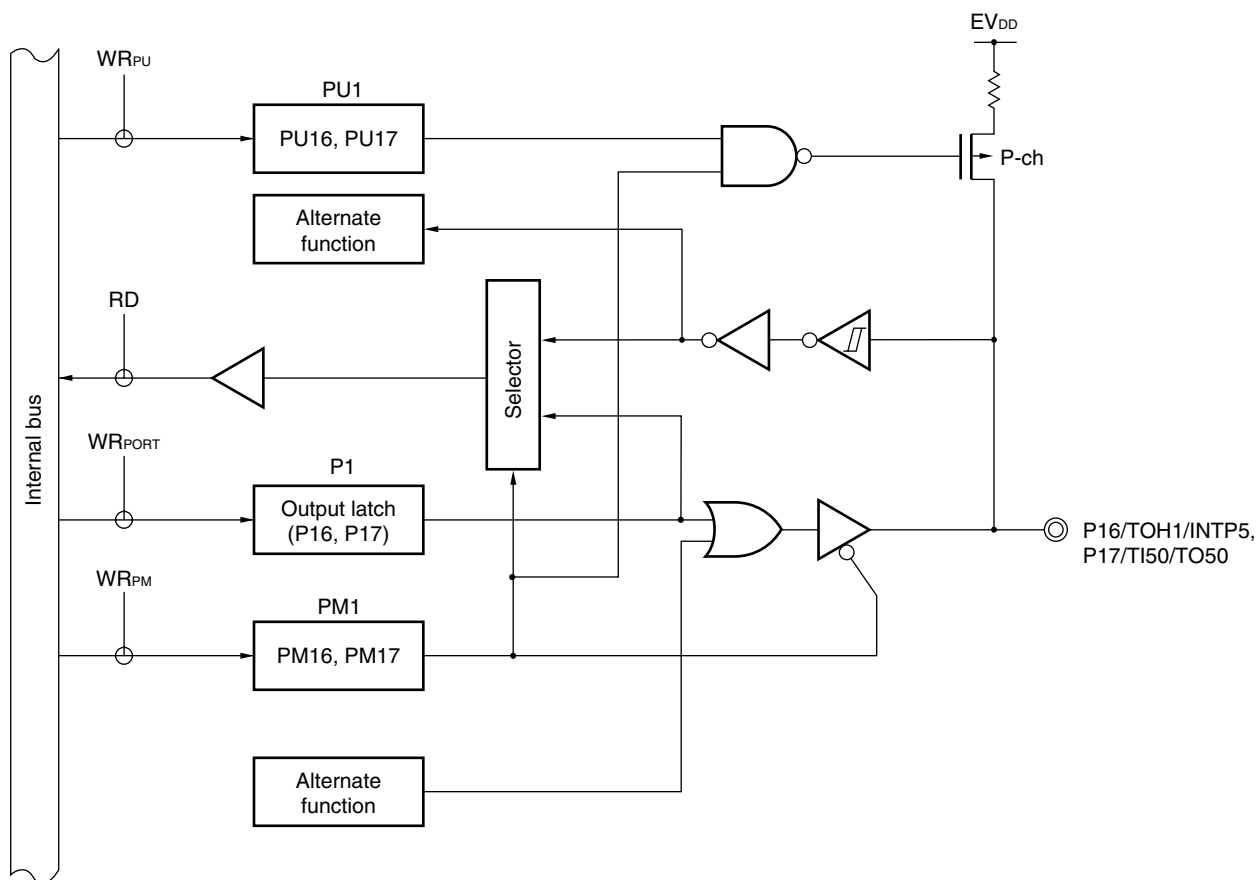

- P1: Port register 1
- PU1: Pull-up resistor option register 1
- PM1: Port mode register 1
- RD: Read signal
- WR_{xx}: Write signal

Remark There are not the EV_{DD} pin and the EV_{SS} pin in the 30-pin plastic SSOP (MC-5A4 and MC-CAB types). Therefore, transpose EV_{DD} and EV_{SS} to V_{DD} and V_{SS}, respectively, in the case of the 30-pin plastic SSOP (MC-5A4 and MC-CAB types).

4.2.3 Port 2

Port 2 is an 8-bit I/O port with an output latch. Port 2 can be set to the input mode or output mode in 1-bit units using port mode register 2 (PM2).

This port can also be used for A/D converter analog input.

To use P20/ANI0 to P23/ANI3 as digital input pins, set them in the digital I/O mode by using the A/D port configuration register (ADPC) and in the input mode by using PM2. Use these pins starting from the lower bit.

To use P20/ANI0 to P23/ANI3 as digital output pins, set them in the digital I/O mode by using ADPC and in the output mode by using PM2.

Table 4-4. Setting Functions of P20/ANI0 to P23/ANI3 Pins

ADPC	PM2	ADS	P20/ANI0 to P23/ANI3 Pin
Digital I/O selection	Input mode	–	Digital input
	Output mode	–	Digital output
Analog input selection	Input mode	Selects ANI.	Analog input (to be converted)
		Does not select ANI.	Analog input (not to be converted)
	Output mode	Selects ANI.	Setting prohibited
		Does not select ANI.	Setting prohibited

<R>

All P20/ANI0 to P23/ANI3 are set in the analog input mode when the reset signal is generated.

Figure 4-9 shows a block diagram of port 2.

<R>

Caution Make the AV_{REF} pin the same potential as the V_{DD} pin when port 2 is used as a digital port.

Figure 4-9. Block Diagram of P20 to P23

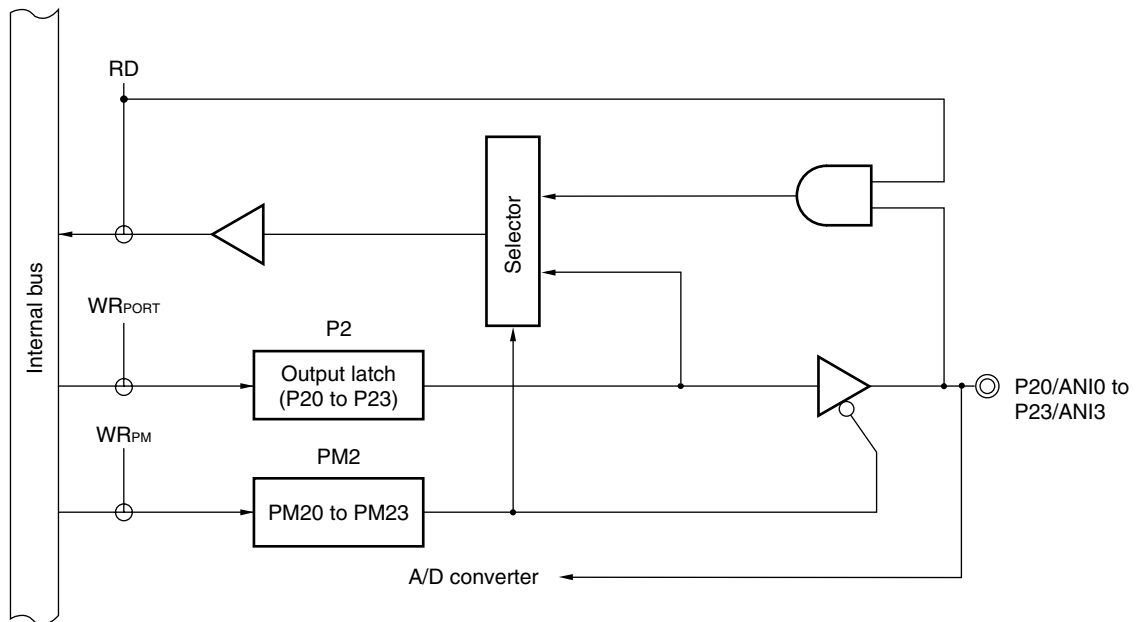

- P2: Port register 2
- PM2: Port mode register 2
- RD: Read signal
- WR_{xx}: Write signal

4.2.4 Port 3

Port 3 is a 4-bit I/O port with an output latch. Port 3 can be set to the input mode or output mode in 1-bit units using port mode register 3 (PM3). When the P30 to P33 pins are used as an input port, use of an on-chip pull-up resistor can be specified in 1-bit units by pull-up resistor option register 3 (PU3).

This port can also be used for external interrupt request input and timer I/O.

Reset signal generation sets port 3 to input mode.

Figures 4-10 and 4-11 show block diagrams of port 3.

Cautions 1. In the products with an on-chip debug function (μ PD78F0503D), be sure to pull the P31/INTP2/OCD1A^{Note} pin down before a reset release, to prevent malfunction.

<R> 2. For the products with an on-chip debug function (μ PD78F0503D), connect P31/INTP2/OCD1A^{Note} as follows when writing the flash memory with a flash memory programmer.

- P31/INTP2/OCD1A^{Note}: Connect to V_{SS} via a resistor (10 k Ω : recommended).

The above connection is not necessary when writing the flash memory by means of self programming.

<R> **Note** OCD1A is provided to the μ PD78F0503D only.

Remark The P31 and P32 pins of the μ PD78F0503D can be used as on-chip debug mode setting pins (OCD1A, OCD1B) when the on-chip debug function is used. For details, see **CHAPTER 22 ON-CHIP DEBUG FUNCTION (μ PD78F0503D ONLY)**.

Figure 4-10. Block Diagram of P30 to P32

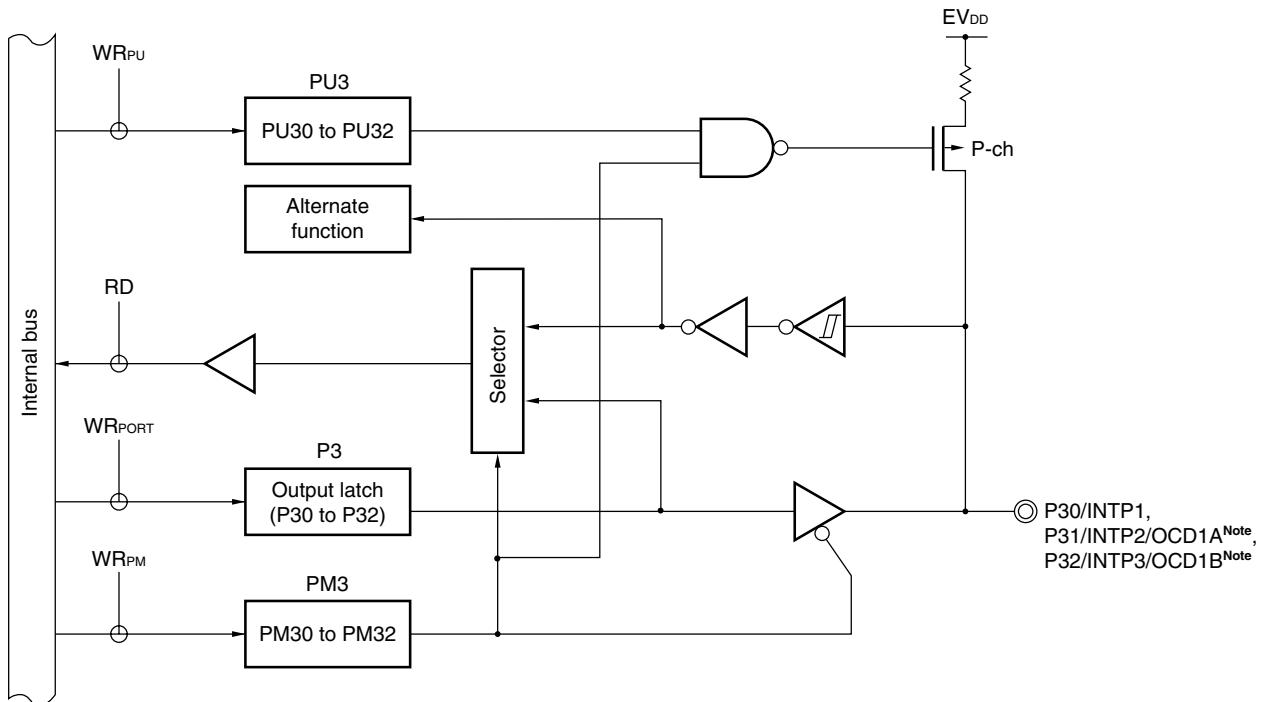

- P3: Port register 3
- PU3: Pull-up resistor option register 3
- PM3: Port mode register 3
- RD: Read signal
- WR_{xx}: Write signal

Note μ PD78F0503D only

Remark There are not the EV_{DD} pin and the EV_{SS} pin in the 30-pin plastic SSOP (MC-5A4 and MC-CAB types). Therefore, transpose EV_{DD} and EV_{SS} to V_{DD} and V_{SS}, respectively, in the case of the 30-pin plastic SSOP (MC-5A4 and MC-CAB types).

Figure 4-11. Block Diagram of P33

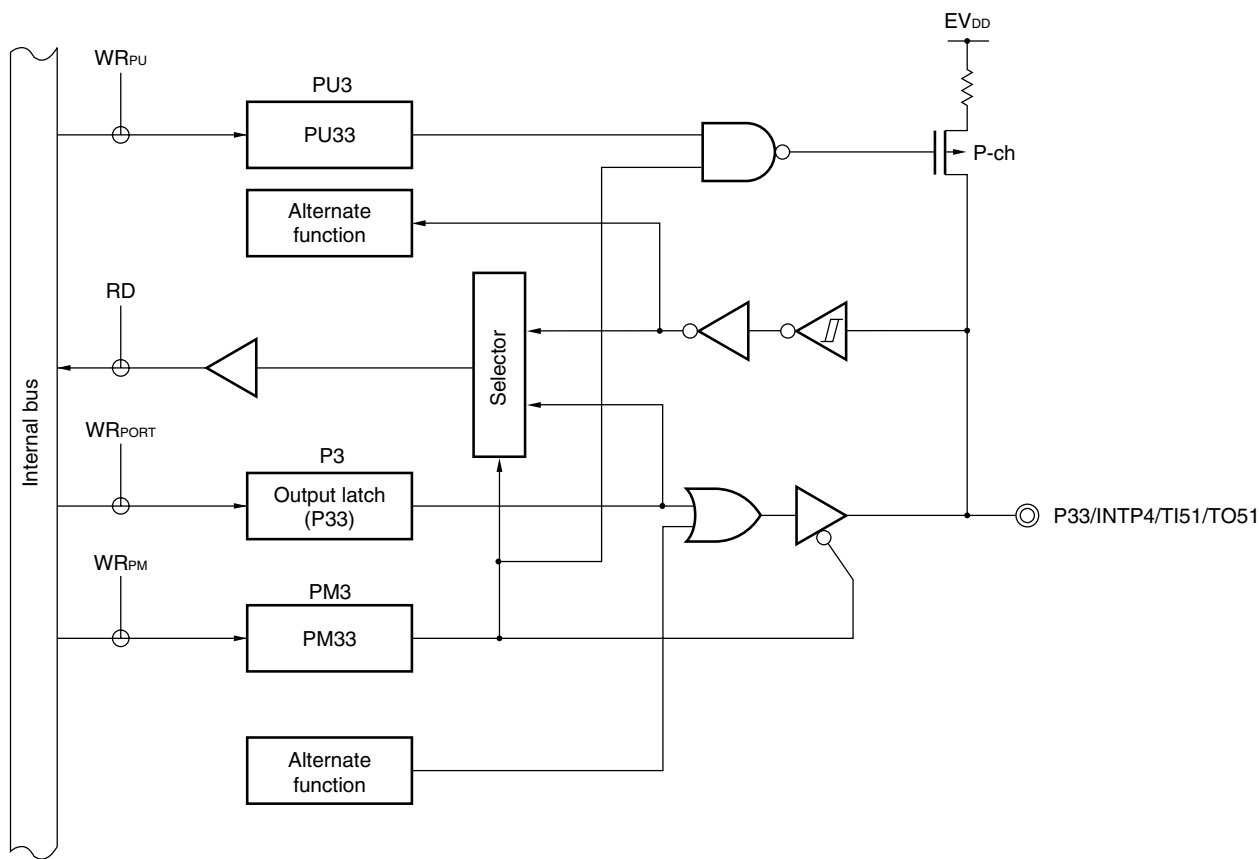

- P3: Port register 3
- PU3: Pull-up resistor option register 3
- PM3: Port mode register 3
- RD: Read signal
- WR_{xx}: Write signal

Remark There are not the EV_{DD} pin and the EV_{SS} pin in the 30-pin plastic SSOP (MC-5A4 and MC-CAB types). Therefore, transpose EV_{DD} and EV_{SS} to V_{DD} and V_{SS}, respectively, in the case of the 30-pin plastic SSOP (MC-5A4 and MC-CAB types).

4.2.5 Port 6

Port 6 is a 2-bit I/O port with an output latch. Port 6 can be set to the input mode or output mode in 1-bit units using port mode register 6 (PM6).

The output is N-ch open-drain output (6 V tolerance).

This port can also be used for serial interface data I/O and clock I/O.

Reset signal generation sets port 6 to input mode.

Figures 4-12 shows a block diagram of port 6.

Remark When using P62/EXSCL0 as an external clock input pin of the serial interface, input a clock of 6.4 MHz to it.

Figure 4-12. Block Diagram of P60 and P61

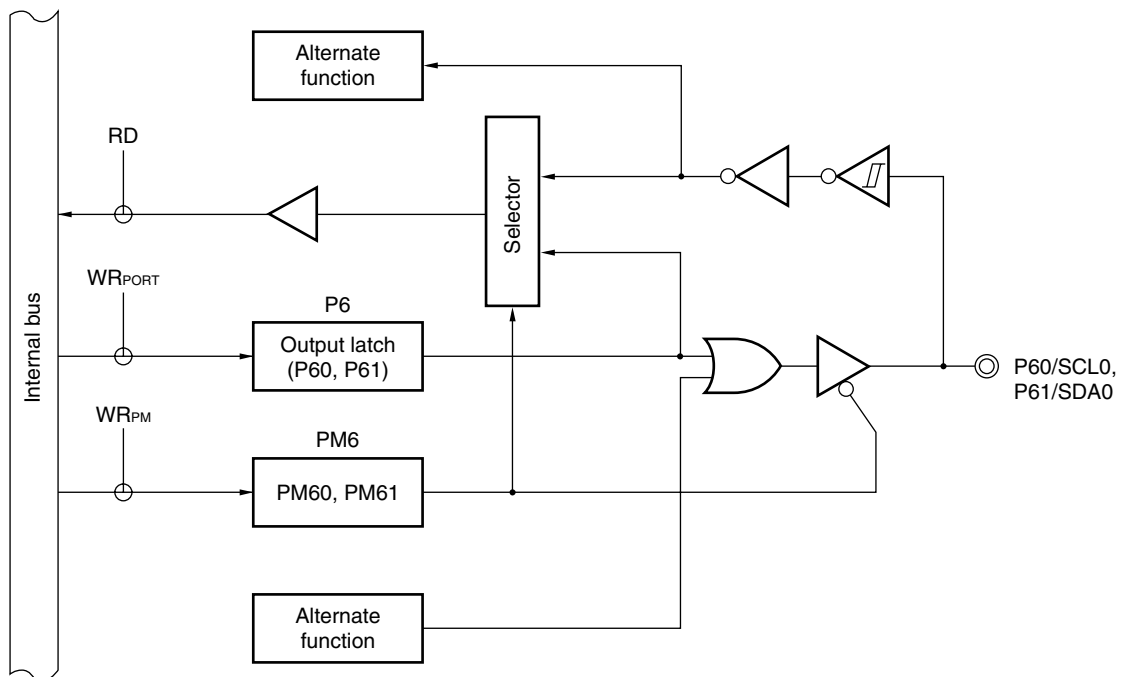

- P6: Port register 6
- PM6: Port mode register 6
- RD: Read signal
- WR_{xx}: Write signal

4.2.6 Port 12

Port 12 is a 3-bit I/O port with an output latch. Port 12 can be set to the input mode or output mode in 1-bit units using port mode register 12 (PM12). When used as an input port only for P120, use of an on-chip pull-up resistor can be specified by pull-up resistor option register 12 (PU12).

This port can also be used as pins for external interrupt request input, potential input for external low-voltage detection, connecting resonator for main system clock, and external clock input for main system clock.

Reset signal generation sets port 12 to input mode.

Figures 4-13 and 4-14 show block diagrams of port 12.

Cautions 1. When using the P121 and P122 pins to connect a resonator for the main system clock (X1, X2), or to input an external clock for the main system clock (EXCLK), the X1 oscillation mode, or external clock input mode must be set by using the clock operation mode select register (OSCCTL) (for details, see 5.3 (1) Clock operation mode select register (OSCCTL). The reset value of OSCCTL is 00H (all of the P121 and P122 pins are I/O port pins). At this time, setting of the PM121 and PM122 and P121 and P122 pins is not necessary.

<R> 2. For the product with an on-chip debug function (μ PD78F0503D), connect P121/X1/OCD0A^{Note} as follows when writing the flash memory with a flash memory programmer.

- P121/X1/OCD0A^{Note}: When using this pin as a port, connect it to V_{SS} via a resistor (10 k Ω : recommended) (in the input mode) or leave it open (in the output mode)

The above connection is not necessary when writing the flash memory by means of self programming.

<R> **Note** OCD0A is provided to the μ PD78F0503D only.

Remark The X1 and X2 pins of the μ PD78F0503D can be used as on-chip debug mode setting pins (OCD0A, OCD0B) when the on-chip debug function is used. For details, see **CHAPTER 22 ON-CHIP DEBUG FUNCTION (μ PD78F0503D ONLY)**.

Figure 4-13. Block Diagram of P120

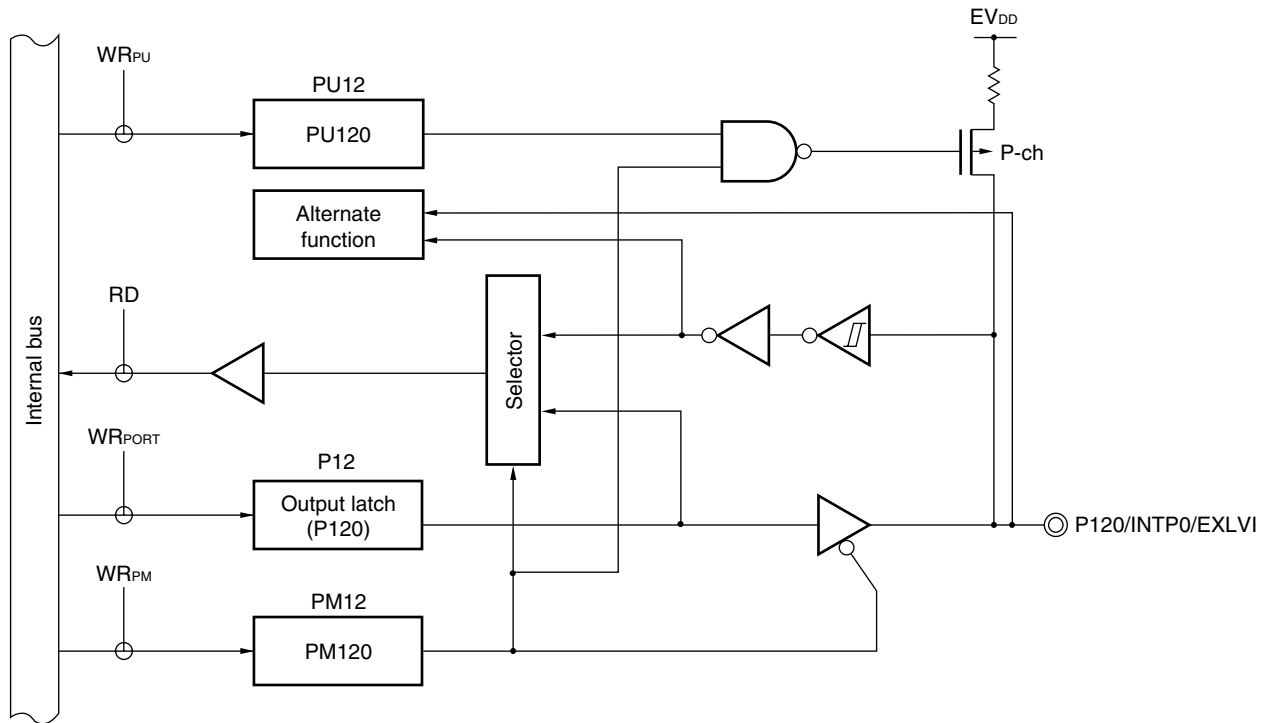

P12: Port register 12
 PU12: Pull-up resistor option register 12
 PM12: Port mode register 12
 RD: Read signal
 WR_{xx} : Write signal

Remark There are not the EV_{DD} pin and the EV_{SS} pin in the 30-pin plastic SSOP (MC-5A4 and MC-CAB types). Therefore, transpose EV_{DD} and EV_{SS} to V_{DD} and V_{SS} , respectively, in the case of the 30-pin plastic SSOP (MC-5A4 and MC-CAB types).

Figure 4-14. Block Diagram of P121 and P122

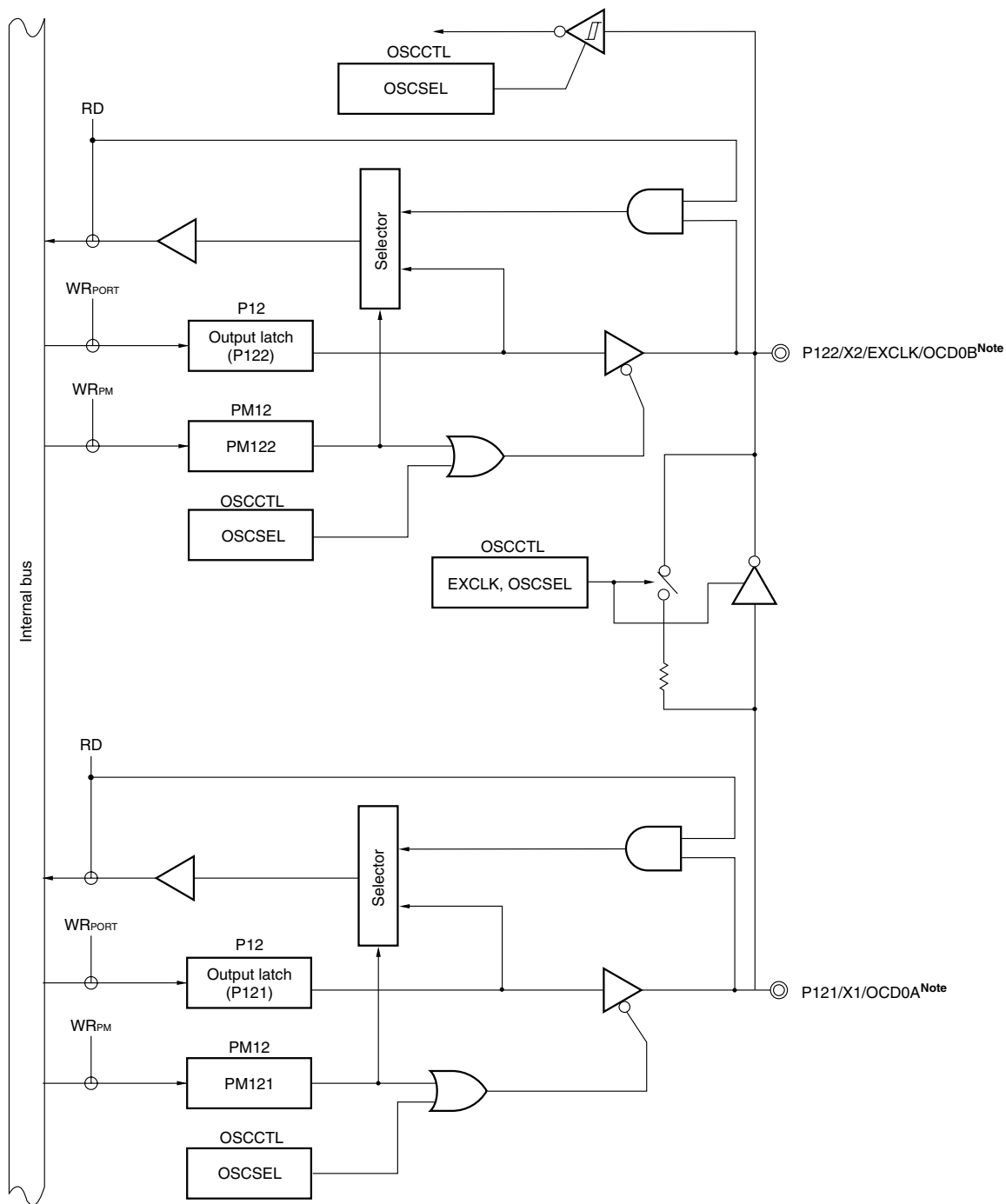

- P12: Port register 12
- PU12: Pull-up resistor option register 12
- PM12: Port mode register 12
- OSCCTL: Clock operation mode select register
- RD: Read signal
- WR_{xx}: Write signal

Note μ PD78F0503D only

4.3 Registers Controlling Port Function

Port functions are controlled by the following four types of registers.

- Port mode registers (PM0 to PM3, PM6, PM12)
- Port registers (P0 to P3, P6, P12)
- Pull-up resistor option registers (PU0, PU1, PU3, PU12)
- A/D port configuration register (ADPC)

(1) Port mode registers (PM0 to PM3, PM6, and PM12)

These registers specify input or output mode for the port in 1-bit units.

These registers can be set by a 1-bit or 8-bit memory manipulation instruction.

Reset signal generation sets these registers to FFH.

When port pins are used as alternate-function pins, set the port mode register by referencing **4.5 Settings of Port Mode Register and Output Latch When Using Alternate Function**.

Figure 4-15. Format of Port Mode Register

Symbol	7	6	5	4	3	2	1	0	Address	After reset	R/W
PM0	1	1	1	1	1	1	PM01	PM00	FF20H	FFH	R/W
PM1	PM17	PM16	PM15	PM14	PM13	PM12	PM11	PM10	FF21H	FFH	R/W
PM2	1	1	1	1	PM23	PM22	PM21	PM20	FF22H	FFH	R/W
PM3	1	1	1	1	PM33	PM32	PM31	PM30	FF23H	FFH	R/W
PM6	1	1	1	1	1	1	PM61	PM60	FF26H	FFH	R/W
PM12	1	1	1	1	1	PM122	PM121	PM120	FF2CH	FFH	R/W

PMmn	Pmn pin I/O mode selection (m = 0 to 3, 6, 12; n = 0 to 7)
0	Output mode (output buffer on)
1	Input mode (output buffer off)

<R> **Caution** Be sure to set bits 2 to 7 of PM0, bits 4 to 7 of PM2, bits 4 to 7 of PM3, bits 2 to 7 of PM6, bits 3 to 7 of PM12 to 1.

(2) Port registers (P0 to P3, P6, and P12)

These registers write the data that is output from the chip when data is output from a port.

If the data is read in the input mode, the pin level is read. If it is read in the output mode, the value of the output latch is read.

These registers can be set by a 1-bit or 8-bit memory manipulation instruction.

Reset signal generation sets these registers to 00H.

Figure 4-16. Format of Port Register

Symbol	7	6	5	4	3	2	1	0	Address	After reset	R/W
P0	0	0	0	0	0	0	P01	P00	FF00H	00H (output latch)	R/W
P1	P17	P16	P15	P14	P13	P12	P11	P10	FF01H	00H (output latch)	R/W
P2	0	0	0	0	P23	P22	P21	P20	FF02H	00H (output latch)	R/W
P3	0	0	0	0	P33	P32	P31	P30	FF03H	00H (output latch)	R/W
P6	0	0	0	0	0	0	P61	P60	FF06H	00H (output latch)	R/W
P12	0	0	0	0	0	P122 ^{Note}	P121 ^{Note}	P120	FF0CH	00H (output latch)	R/W

Pmn	m = 0 to 3, 6, 12; n = 0 to 7	
	Output data control (in output mode)	Input data read (in input mode)
0	Output 0	Input low level
1	Output 1	Input high level

<R>

Note “0” is always read from the output latch of P121 and P122 if the pin is in the external clock input mode.

(3) Pull-up resistor option registers (PU0, PU1, PU3, and PU12)

These registers specify whether the on-chip pull-up resistors of P00, P01, P10 to P17, P30 to P33, or P120 are to be used or not. On-chip pull-up resistors can be used in 1-bit units only for the bits set to input mode of the pins to which the use of an on-chip pull-up resistor has been specified in PU0, PU1, PU3, and PU12. On-chip pull-up resistors cannot be connected to bits set to output mode and bits used as alternate-function output pins, regardless of the settings of PU0, PU1, PU3, and PU12.

These registers can be set by a 1-bit or 8-bit memory manipulation instruction.

Reset signal generation sets these registers to 00H.

Figure 4-17. Format of Pull-up Resistor Option Register

Symbol	7	6	5	4	3	2	1	0	Address	After reset	R/W
PU0	0	0	0	0	0	0	PU01	PU00	FF30H	00H	R/W
PU1	PU17	PU16	PU15	PU14	PU13	PU12	PU11	PU10	FF31H	00H	R/W
PU3	0	0	0	0	PU33	PU32	PU31	PU30	FF33H	00H	R/W
PU12	0	0	0	0	0	0	0	PU120	FF3CH	00H	R/W

PU _m n	P _m n pin on-chip pull-up resistor selection (m = 0, 1, 3, 12; n = 0 to 7)
0	On-chip pull-up resistor not connected
1	On-chip pull-up resistor connected

(4) A/D port configuration register (ADPC)

This register switches the P20/ANI0 to P23/ANI3 pins to digital I/O of port or analog input of A/D converter.

ADPC can be set by a 1-bit or 8-bit memory manipulation instruction.

Reset signal generation sets this register to 00H.

Figure 4-18. Format of A/D Port Configuration Register (ADPC)

Address: FF2FH After reset: 00H R/W

Symbol	7	6	5	4	3	2	1	0
ADPC	0	0	0	0	0	ADPC2	ADPC1	ADPC0

ADPC2	ADPC1	ADPC0	digital I/O (D)/Analog input (A) switching			
			P23/ANI3	P22/ANI2	P21/ANI1	P20/ANI0
0	0	0	A	A	A	A
0	0	1	A	A	A	D
0	1	0	A	A	D	D
0	1	1	A	D	D	D
1	0	0	D	D	D	D
Other than above			Setting prohibited			

- Cautions**
1. Set the channel used for A/D conversion to the input mode by using port mode register 2 (PM2).
 2. If data is written to ADPC, a wait cycle is generated. For details, see CHAPTER 28 CAUTIONS FOR WAIT.
 3. Be sure to clear bits 3 to 7 to 0.

4.4 Port Function Operations

Port operations differ depending on whether the input or output mode is set, as shown below.

4.4.1 Writing to I/O port

(1) Output mode

A value is written to the output latch by a transfer instruction, and the output latch contents are output from the pin.

Once data is written to the output latch, it is retained until data is written to the output latch again.

The data of the output latch is cleared when a reset signal is generated.

(2) Input mode

A value is written to the output latch by a transfer instruction, but since the output buffer is off, the pin status does not change.

Once data is written to the output latch, it is retained until data is written to the output latch again.

The data of the output latch is cleared when a reset signal is generated.

4.4.2 Reading from I/O port

(1) Output mode

The output latch contents are read by a transfer instruction. The output latch contents do not change.

(2) Input mode

The pin status is read by a transfer instruction. The output latch contents do not change.

4.4.3 Operations on I/O port

(1) Output mode

An operation is performed on the output latch contents, and the result is written to the output latch. The output latch contents are output from the pins.

Once data is written to the output latch, it is retained until data is written to the output latch again.

The data of the output latch is cleared when a reset signal is generated.

(2) Input mode

The pin level is read and an operation is performed on its contents. The result of the operation is written to the output latch, but since the output buffer is off, the pin status does not change.

The data of the output latch is cleared when a reset signal is generated.

4.5 Settings of Port Mode Register and Output Latch When Using Alternate Function

To use the alternate function of a port pin, set the port mode register and output latch as shown in Table 4-5.

Table 4-5. Settings of Port Mode Register and Output Latch When Using Alternate Function

Pin Name	Alternate Function		PM _{xx}	P _{xx}
	Function Name	I/O		
P00	TI000	Input	1	×
P01	TI010	Input	1	×
	TO00	Output	0	0
P10	SCK10	Input	1	×
		Output	0	1
	TxD0	Output	0	1
P11	SI10	Input	1	×
	RxD0	Input	1	×
P12	SO10	Output	0	0
P13	TxD6	Output	0	1
P14	RxD6	Input	1	×
P15	TOH0	Output	0	0
P16	TOH1	Output	0	0
	INTP5	Input	1	×
P17	TI50	Input	1	×
	TO50	Output	0	0
P20 to P23 ^{Note 1}	ANI0 to ANI3 ^{Note 1}	Input	1	×
P30 to P32	INTP1 to INTP3	Input	1	×
P33	INTP4	Input	1	×
	TI51	Input	1	×
	TO51	Output	0	0
P60	SCL0	I/O	0	0
P61	SDA0	I/O	0	0
P120	INTP0	Input	1	×
	EXLVI	Input	1	×
P121	X1 ^{Note 2}	–	×	×
P122	X2 ^{Note 2}	–	×	×
	EXCLK ^{Note 2}	Input	×	×

Remarks 1. ×: Don't care

PM_{xx}: Port mode register

P_{xx}: Port output latch

2. The X1, X2, P31, and P32 pins of the μ PD78F0503D can be used as on-chip debug mode setting pins (OCD0A, OCD0B, OCD1A, OCD1B) when the on-chip debug function is used. For details, see **CHAPTER 22 ON-CHIP DEBUG FUNCTION (μ PD78F0503D ONLY)**.

(Notes 1 and 2 are listed on the next page.)

Notes 1. The function of the ANI0/P20 to ANI3/P23 pins can be selected by using the A/D port configuration register (ADPC), the analog input channel specification register (ADS), and PM2.

Table 4-6. Setting Functions of ANI0/P20 to ANI3/P23 Pins

ADPC	PM2	ADS	ANI0/P20 to ANI3/P23 Pins
Analog input selection	Input mode	Selects ANI.	Analog input (to be converted)
		Does not select ANI.	Analog input (not to be converted)
	Output mode	Selects ANI.	Setting prohibited
		Does not select ANI.	
Digital I/O selection	Input mode	–	Digital input
	Output mode	–	Digital output

<R>

- When using the P121 and P122 pins to connect a resonator for the main system clock (X1, X2), or to input an external clock for the main system clock (EXCLK), the X1 oscillation mode, or external clock input mode must be set by using the clock operation mode select register (OSCCTL) (for details, see **5.3 (1) Clock operation mode select register (OSCCTL)**). The reset value of OSCCTL is 00H (all of the P121 and P122 are I/O port pins). At this time, setting of PM121 and PM122 and P121 and P122 is not necessary.

<R>

4.6 Cautions on 1-Bit Manipulation Instruction for Port Register n (Pn)

When a 1-bit manipulation instruction is executed on a port that provides both input and output functions, the output latch value of an input port that is not subject to manipulation may be written in addition to the targeted bit.

Therefore, it is recommended to rewrite the output latch when switching a port from input mode to output mode.

<Example> When P10 is an output port, P11 to P17 are input ports (all pin statuses are high level), and the port latch value of port 1 is 00H, if the output of output port P10 is changed from low level to high level via a 1-bit manipulation instruction, the output latch value of port 1 is FFH.

Explanation: The targets of writing to and reading from the Pn register of a port whose PMnm bit is 1 are the output latch and pin status, respectively.

A 1-bit manipulation instruction is executed in the following order in the 78K0/KB2.

- <1> The Pn register is read in 8-bit units.
- <2> The targeted one bit is manipulated.
- <3> The Pn register is written in 8-bit units.

In step <1>, the output latch value (0) of P10, which is an output port, is read, while the pin statuses of P11 to P17, which are input ports, are read. If the pin statuses of P11 to P17 are high level at this time, the read value is FEH.

The value is changed to FFH by the manipulation in <2>.

FFH is written to the output latch by the manipulation in <3>.

Figure 4-19. Bit Manipulation Instruction (P10)

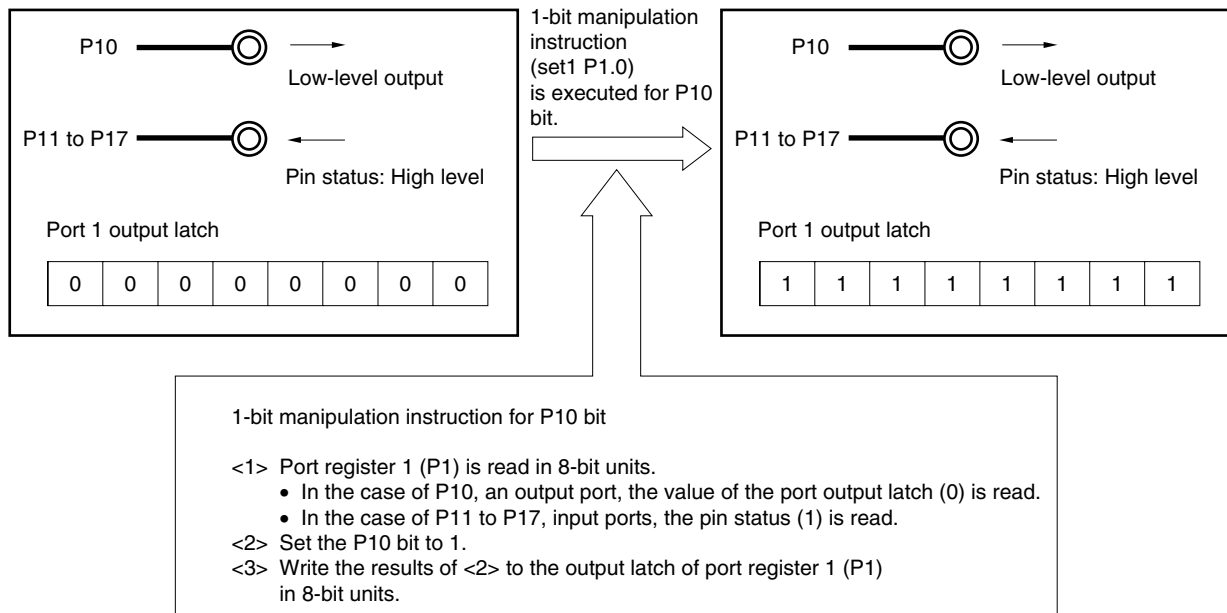

CHAPTER 5 CLOCK GENERATOR

5.1 Functions of Clock Generator

The clock generator generates the clock to be supplied to the CPU and peripheral hardware. The following kinds of system clocks and clock oscillators are selectable.

(1) Main system clock

<1> X1 oscillator

This circuit oscillates a clock of $f_x = 1$ to 20 MHz by connecting a resonator to X1 and X2.

Oscillation can be stopped by executing the STOP instruction or using the main OSC control register (MOC).

<2> Internal high-speed oscillator

This circuit oscillates a clock of $f_{RH} = 8$ MHz (TYP.). After a reset release, the CPU always starts operating with this internal high-speed oscillation clock. Oscillation can be stopped by executing the STOP instruction or using the internal oscillation mode register (RCM).

An external main system clock ($f_{EXCLK} = 1$ to 20 MHz) can also be supplied from the EXCLK/X2/P122 pin. An external main system clock input can be disabled by executing the STOP instruction or using RCM.

As the main system clock, a high-speed system clock (X1 clock or external main system clock) or internal high-speed oscillation clock can be selected by using the main clock mode register (MCM).

(2) Internal low-speed oscillation clock (clock for watchdog timer)

• Internal low-speed oscillator

This circuit oscillates a clock of $f_{RL} = 240$ kHz (TYP.). After a reset release, the internal low-speed oscillation clock always starts operating.

Oscillation can be stopped by using the internal oscillation mode register (RCM) when “internal low-speed oscillator can be stopped by software” is set by option byte.

The internal low-speed oscillation clock cannot be used as the CPU clock. The following hardware operates with the internal low-speed oscillation clock.

- Watchdog timer
- TMH1 (when f_{RL} , $f_{RL}/2^7$, or $f_{RL}/2^9$ is selected)

- Remarks**
1. f_x : X1 clock oscillation frequency
 2. f_{RH} : Internal high-speed oscillation clock frequency
 3. f_{EXCLK} : External main system clock frequency
 4. f_{RL} : Internal low-speed oscillation clock frequency

5.2 Configuration of Clock Generator

The clock generator includes the following hardware.

Table 5-1. Configuration of Clock Generator

Item	Configuration
Control registers	Clock operation mode select register (OSCCTL) Processor clock control register (PCC) Internal oscillation mode register (RCM) Main OSC control register (MOC) Main clock mode register (MCM) Oscillation stabilization time counter status register (OSTC) Oscillation stabilization time select register (OSTS)
Oscillators	X1 oscillator Internal high-speed oscillator Internal low-speed oscillator

Figure 5-1. Block Diagram of Clock Generator

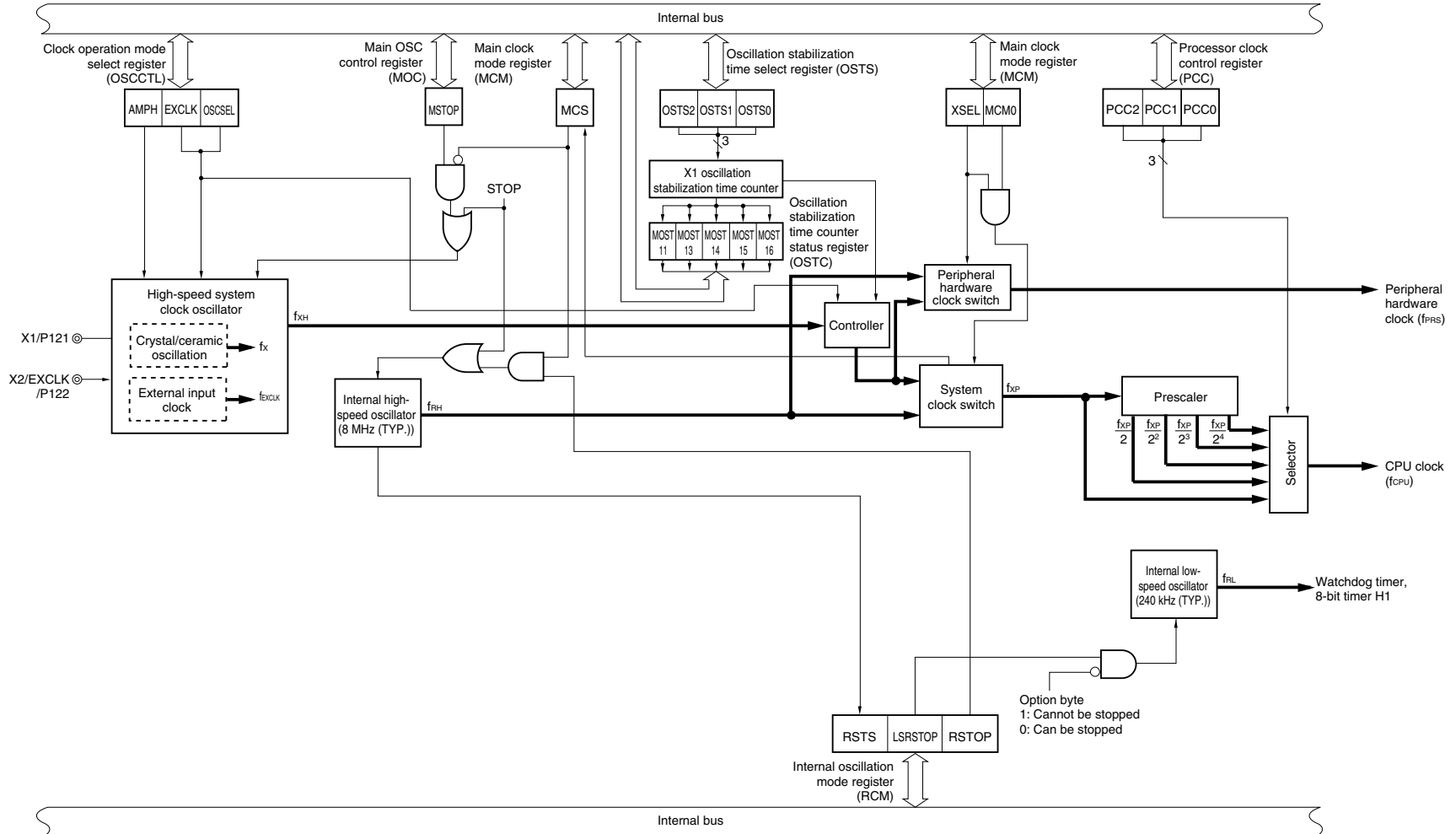

- Remarks**
1. f_X : X1 clock oscillation frequency
 2. f_{RH} : Internal high-speed oscillation clock frequency
 3. f_{EXCLK} : External main system clock frequency
 4. f_{XH} : High-speed system clock oscillation frequency
 5. f_{XP} : Main system clock oscillation frequency
 6. f_{PRS} : Peripheral hardware clock oscillation frequency
 7. f_{CPU} : CPU clock oscillation frequency
 8. f_{RL} : Internal low-speed oscillation clock frequency

5.3 Registers Controlling Clock Generator

The following seven registers are used to control the clock generator.

- Clock operation mode select register (OSCCTL)
- Processor clock control register (PCC)
- Internal oscillation mode register (RCM)
- Main OSC control register (MOC)
- Main clock mode register (MCM)
- Oscillation stabilization time counter status register (OSTC)
- Oscillation stabilization time select register (OSTS)

(1) Clock operation mode select register (OSCCTL)

This register selects the operation mode of the high-speed system clock, and the gain of the on-chip oscillator.

OSCCTL can be set by a 1-bit or 8-bit memory manipulation instruction.

Reset signal generation sets this register to 00H.

Figure 5-2. Format of Clock Operation Mode Select Register (OSCCTL)

Address: FF9FH After reset: 00H R/W

Symbol	<7>	<6>	5	4	3	2	1	<0>
OSCCTL	EXCLK	OSCSEL	0	0	0	0	0	AMPH

EXCLK	OSCSEL	High-speed system clock pin operation mode	P121/X1 pin	P122/X2/EXCLK pin
0	0	I/O port mode	I/O port	
0	1	X1 oscillation mode	Crystal/ceramic resonator connection	
1	0	I/O port mode	I/O port	
1	1	External clock input mode	I/O port	External clock input

AMPH	Operating frequency control
0	$1 \text{ MHz} \leq f_{XH} \leq 10 \text{ MHz}$
1	$10 \text{ MHz} < f_{XH} \leq 20 \text{ MHz}$

- Cautions**
1. Be sure to set AMPH to 1 if the high-speed system clock oscillation frequency exceeds 10 MHz.
 2. Set AMPH before setting the peripheral functions after a reset release. The value of AMPH can be changed only once after a reset release. When the high-speed system clock (X1 oscillation) is selected as the CPU clock, supply of the CPU clock is stopped for 4.06 to 16.12 μs after AMPH is set to 1. When the high-speed system clock (external clock input) is selected as the CPU clock, supply of the CPU clock is stopped for the duration of 160 external clocks after AMPH is set to 1.
 3. If the STOP instruction is executed when AMPH = 1, supply of the CPU clock is stopped for 4.06 to 16.12 μs after the STOP mode is released when the internal high-speed oscillation clock is selected as the CPU clock, or for the duration of 160 external clocks when the high-speed system clock (external clock input) is selected as the CPU clock. When the high-speed system clock (X1 oscillation) is selected as the CPU clock, the oscillation stabilization time is counted after the STOP mode is released.
 4. To change the value of EXCLK and OSCSEL, be sure to confirm that bit 7 (MSTOP) of the main OSC control register (MOC) is 1 (the X1 oscillator stops or the external clock from the EXCLK pin is disabled).
 5. Be sure to clear bits 1 to 5 to 0.

Remark f_{XH} : High-speed system clock oscillation frequency

(2) Processor clock control register (PCC)

This register is used to select the CPU clock, and the division ratio.

PCC is set by a 1-bit or 8-bit memory manipulation instruction.

Reset signal generation sets PCC to 01H.

Figure 5-3. Format of Processor Clock Control Register (PCC)

Address: FFFBH After reset: 01H R/W^{Note 1}

Symbol	7	6	5	4	3	2	1	0
PCC	0	0	0	0	0	PCC2	PCC1	PCC0

PCC2	PCC1	PCC0	CPU clock (f _{CPU}) selection
0	0	0	f _{XP}
0	0	1	f _{XP} /2 (default)
0	1	0	f _{XP} /2 ²
0	1	1	f _{XP} /2 ³
1	0	0	f _{XP} /2 ⁴
Other than above			Setting prohibited

Caution Be sure to clear bits 3 to 7 to 0.

Remark f_{XP}: Main system clock oscillation frequency

The fastest instruction can be executed in 2 clocks of the CPU clock in the 78K0/KB2. Therefore, the relationship between the CPU clock (f_{CPU}) and the minimum instruction execution time is as shown in Table 5-2.

Table 5-2. Relationship Between CPU Clock and Minimum Instruction Execution Time

CPU Clock (f_{CPU})	Minimum Instruction Execution Time: $2/f_{CPU}$		
	Main System Clock		
	High-Speed System Clock ^{Note}		Internal High-Speed Oscillation Clock ^{Note}
	At 10 MHz Operation	At 20 MHz Operation	At 8 MHz (TYP.) Operation
f_{XP}	0.2 μs	0.1 μs	0.25 μs (TYP.)
$f_{XP}/2$	0.4 μs	0.2 μs	0.5 μs (TYP.)
$f_{XP}/2^2$	0.8 μs	0.4 μs	1.0 μs (TYP.)
$f_{XP}/2^3$	1.6 μs	0.8 μs	2.0 μs (TYP.)
$f_{XP}/2^4$	3.2 μs	1.6 μs	4.0 μs (TYP.)

Note The main clock mode register (MCM) is used to set the main system clock supplied to CPU clock (high-speed system clock/internal high-speed oscillation clock) (see **Figure 5-6**).

(3) Internal oscillation mode register (RCM)

This register sets the operation mode of internal oscillator.

RCM can be set by a 1-bit or 8-bit memory manipulation instruction.

Reset signal generation sets this register to 80H^{Note 1}.

Figure 5-4. Format of Internal Oscillation Mode Register (RCM)

Address: FFA0H After reset: 80H^{Note 1} R/W^{Note 2}

Symbol	<7>	6	5	4	3	2	<1>	<0>
RCM	RSTS	0	0	0	0	0	LSRSTOP	RSTOP

RSTS	Status of internal high-speed oscillator
0	Waiting for accuracy stabilization of internal high-speed oscillator
1	Stability operating of internal high-speed oscillator

LSRSTOP	Internal low-speed oscillator oscillating/stopped
0	Internal low-speed oscillator oscillating
1	Internal low-speed oscillator stopped

RSTOP	Internal high-speed oscillator oscillating/stopped
0	Internal high-speed oscillator oscillating
1	Internal high-speed oscillator stopped

Notes 1. The value of this register is 00H immediately after a reset release but automatically changes to 80H after internal high-speed oscillator has been stabilized.

2. Bit 7 is read-only.

Caution When setting RSTOP to 1, be sure to confirm that the CPU operates with the high-speed system clock (MCS = 1).

In addition, stop peripheral hardware that is operating on the internal high-speed oscillation clock before setting RSTOP to 1.

(4) Main OSC control register (MOC)

This register selects the operation mode of the high-speed system clock.

This register is used to stop the X1 oscillator or to disable an external clock input from the EXCLK pin when the CPU operates with the internal high-speed oscillation clock.

MOC can be set by a 1-bit or 8-bit memory manipulation instruction.

Reset signal generation sets this register to 80H.

Figure 5-5. Format of Main OSC Control Register (MOC)

Address: FFA2H After reset: 80H R/W

Symbol	<7>	6	5	4	3	2	1	0
MOC	MSTOP	0	0	0	0	0	0	0

MSTOP	Control of high-speed system clock operation	
	X1 oscillation mode	External clock input mode
0	X1 oscillator operating	External clock from EXCLK pin is enabled
1	X1 oscillator stopped	External clock from EXCLK pin is disabled

- Cautions**
1. When setting MSTOP to 1, be sure to confirm that the CPU operates with the internal high-speed oscillation clock (MCS = 0).
In addition, stop peripheral hardware that is operating on the high-speed system clock before setting MSTOP to 1.
 2. Do not clear MSTOP to 0 while bit 6 (OSCSEL) of the clock operation mode select register (OSCCTL) is 0 (I/O port mode).
 3. The peripheral hardware cannot operate when the peripheral hardware clock is stopped. To resume the operation of the peripheral hardware after the peripheral hardware clock has been stopped, initialize the peripheral hardware.

(5) Main clock mode register (MCM)

This register selects the main system clock supplied to CPU clock and clock supplied to peripheral hardware clock.

MCM can be set by a 1-bit or 8-bit memory manipulation instruction.

Reset signal generation sets this register to 00H.

Figure 5-6. Format of Main Clock Mode Register (MCM)

Address: FFA1H After reset: 00H R/W^{Note}

Symbol	7	6	5	4	3	<2>	<1>	<0>
MCM	0	0	0	0	0	XSEL	MCS	MCM0

XSEL	MCM0	Selection of clock supplied to main system clock and peripheral hardware	
		Main system clock (f _{XP})	Peripheral hardware clock (f _{PRS})
0	0	Internal high-speed oscillation clock (f _{RH})	Internal high-speed oscillation clock (f _{RH})
0	1		High-speed system clock (f _{XH})
1	0	High-speed system clock (f _{XH})	
1	1	High-speed system clock (f _{XH})	

MCS	Main system clock status
0	Operates with internal high-speed oscillation clock
1	Operates with high-speed system clock

Note Bit 1 is read-only.

- Cautions**
1. XSEL can be changed only once after a reset release.
 2. A clock other than f_{PRS} is supplied to the following peripheral functions regardless of the setting of XSEL and MCM0.
 - Watchdog timer (operates with internal low-speed oscillation clock)
 - When “f_{RL}”, “f_{RL}/2⁷”, or “f_{RL}/2⁹” is selected as the count clock for 8-bit timer H1 (operates with internal low-speed oscillation clock)
 - Peripheral hardware selects the external clock as the clock source (Except when the external count clock of TM00 is selected (TI000 pin valid edge))

(6) Oscillation stabilization time counter status register (OSTC)

This is the register that indicates the count status of the X1 clock oscillation stabilization time counter. When X1 clock oscillation starts with the internal high-speed oscillation clock used as the CPU clock, the X1 clock oscillation stabilization time can be checked.

OSTC can be read by a 1-bit or 8-bit memory manipulation instruction.

When reset is released (reset by $\overline{\text{RESET}}$ input, POC, LVI, and WDT), the STOP instruction and MSTOP (bit 7 of MOC register) = 1 clear OSTC to 00H.

Figure 5-7. Format of Oscillation Stabilization Time Counter Status Register (OSTC)

Address: FFA3H After reset: 00H R

Symbol	7	6	5	4	3	2	1	0
OSTC	0	0	0	MOST11	MOST13	MOST14	MOST15	MOST16

MOST11	MOST13	MOST14	MOST15	MOST16	Oscillation stabilization time status	
					$f_x = 10 \text{ MHz}$	$f_x = 20 \text{ MHz}$
1	0	0	0	0	$2^{11}/f_x \text{ min.}$	204.8 μs min. / 102.4 μs min.
1	1	0	0	0	$2^{13}/f_x \text{ min.}$	819.2 μs min. / 409.6 μs min.
1	1	1	0	0	$2^{14}/f_x \text{ min.}$	1.64 ms min. / 819.2 μs min.
1	1	1	1	0	$2^{15}/f_x \text{ min.}$	3.27 ms min. / 1.64 ms min.
1	1	1	1	1	$2^{16}/f_x \text{ min.}$	6.55 ms min. / 3.27 ms min.

- Cautions**
1. After the above time has elapsed, the bits are set to 1 in order from MOST11 and remain 1.
 2. The oscillation stabilization time counter counts up to the oscillation stabilization time set by OSTC. If the STOP mode is entered and then released while the internal high-speed oscillation clock is being used as the CPU clock, set the oscillation stabilization time as follows.
 - Desired OSTC oscillation stabilization time \leq Oscillation stabilization time set by OSTC

Note, therefore, that only the status up to the oscillation stabilization time set by OSTC is set to OSTC after STOP mode is released.
 3. The X1 clock oscillation stabilization wait time does not include the time until clock oscillation starts (“a” below).

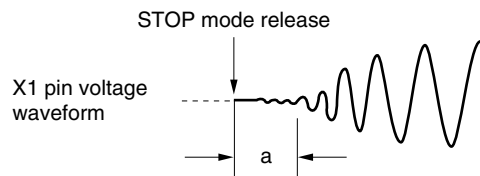

Remark f_x : X1 clock oscillation frequency

(7) Oscillation stabilization time select register (OSTS)

This register is used to select the X1 clock oscillation stabilization wait time when the STOP mode is released. When the X1 clock is selected as the CPU clock, the operation waits for the time set using OSTS after the STOP mode is released.

When the internal high-speed oscillation clock is selected as the CPU clock, confirm with OSTC that the desired oscillation stabilization time has elapsed after the STOP mode is released. The oscillation stabilization time can be checked up to the time set using OSTC.

OSTS can be set by an 8-bit memory manipulation instruction.

Reset signal generation sets OSTS to 05H.

Figure 5-8. Format of Oscillation Stabilization Time Select Register (OSTS)

Address: FFA4H After reset: 05H R/W

Symbol	7	6	5	4	3	2	1	0
OSTS	0	0	0	0	0	OSTS2	OSTS1	OSTS0

OSTS2	OSTS1	OSTS0	Oscillation stabilization time selection		
			fx = 10 MHz	fx = 20 MHz	
0	0	1	$2^{11}/f_x$	204.8 μ s	102.4 μ s
0	1	0	$2^{13}/f_x$	819.2 μ s	409.6 μ s
0	1	1	$2^{14}/f_x$	1.64 ms	819.2 μ s
1	0	0	$2^{15}/f_x$	3.27 ms	1.64 ms
1	0	1	$2^{16}/f_x$	6.55 ms	3.27 ms
Other than above			Setting prohibited		

- Cautions**
- To set the STOP mode when the X1 clock is used as the CPU clock, set OSTS before executing the STOP instruction.**
 - Do not change the value of the OSTS register during the X1 clock oscillation stabilization time.**
 - The oscillation stabilization time counter counts up to the oscillation stabilization time set by OSTS. If the STOP mode is entered and then released while the internal high-speed oscillation clock is being used as the CPU clock, set the oscillation stabilization time as follows.**
 - Desired OSTC oscillation stabilization time \leq Oscillation stabilization time set by OSTS**

Note, therefore, that only the status up to the oscillation stabilization time set by OSTS is set to OSTC after STOP mode is released.
 - The X1 clock oscillation stabilization wait time does not include the time until clock oscillation starts (“a” below).**

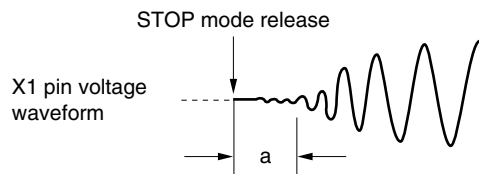

Remark fx: X1 clock oscillation frequency

5.4 System Clock Oscillator

5.4.1 X1 oscillator

The X1 oscillator oscillates with a crystal resonator or ceramic resonator (1 to 20 MHz) connected to the X1 and X2 pins.

<R>

An external clock can also be input. In this case, input the clock signal to the EXCLK pin.

Figure 5-9 shows an example of the external circuit of the X1 oscillator.

Figure 5-9. Example of External Circuit of X1 Oscillator

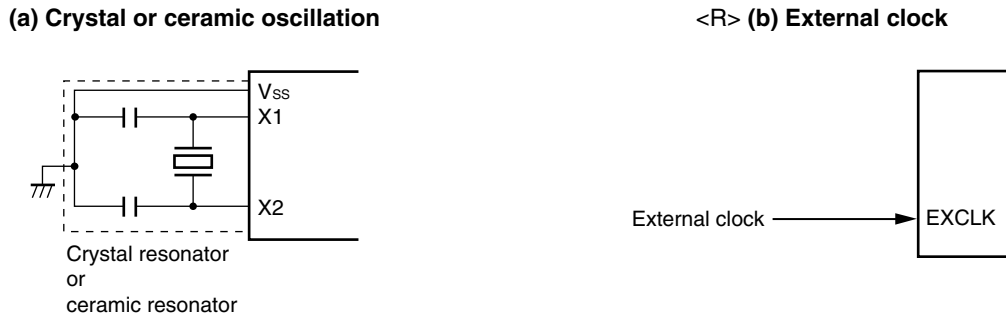

Cautions 1. When using the X1 oscillator, wire as follows in the area enclosed by the broken lines in the Figures 5-9 to avoid an adverse effect from wiring capacitance.

- Keep the wiring length as short as possible.
- Do not cross the wiring with the other signal lines. Do not route the wiring near a signal line through which a high fluctuating current flows.
- Always make the ground point of the oscillator capacitor the same potential as V_{SS}. Do not ground the capacitor to a ground pattern through which a high current flows.
- Do not fetch signals from the oscillator.

Figure 5-10 shows examples of incorrect resonator connection.

Figure 5-10. Examples of Incorrect Resonator Connection (1/2)

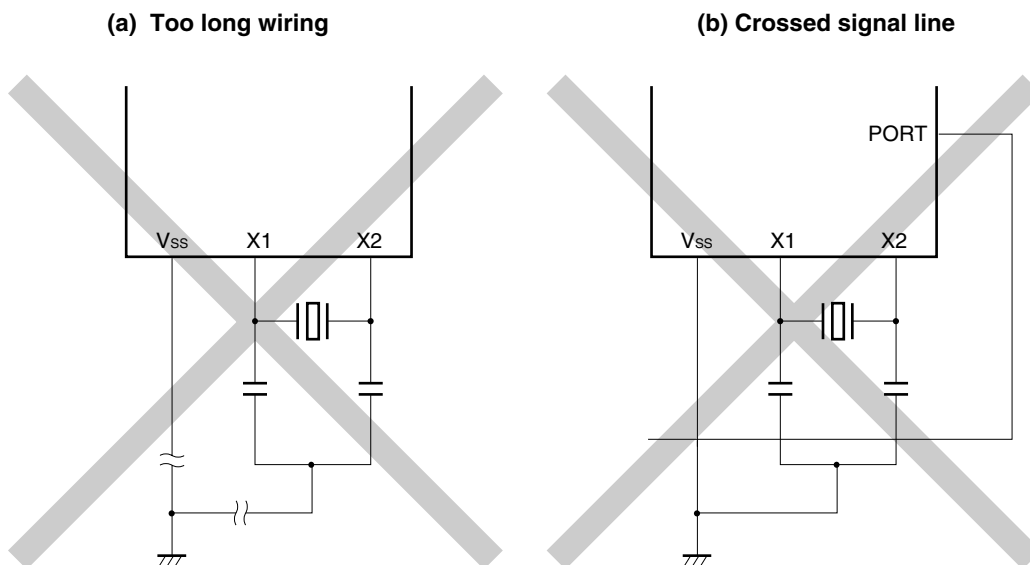
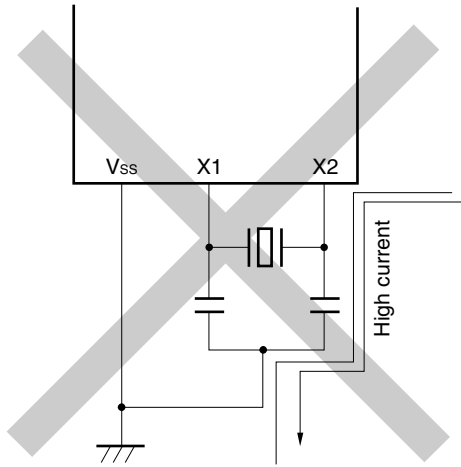
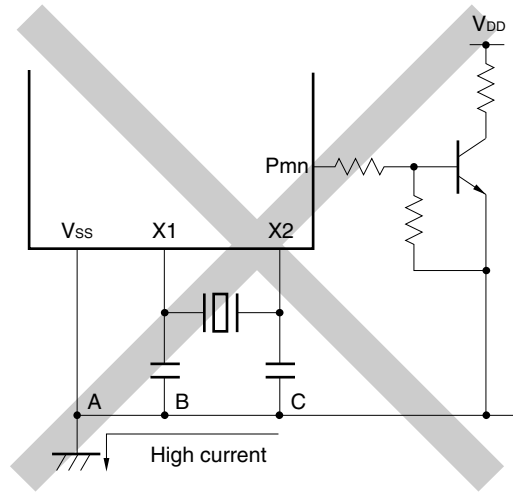

Figure 5-10. Examples of Incorrect Resonator Connection (2/2)

(c) Wiring near high alternating current



(d) Current flowing through ground line of oscillator (potential at points A, B, and C fluctuates)



(e) Signals are fetched

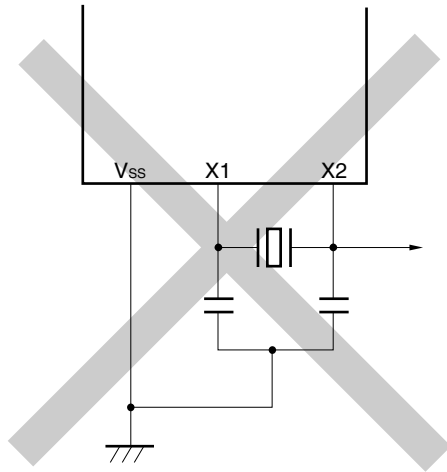

5.4.2 Internal high-speed oscillator

The internal high-speed oscillator is incorporated in the 78K0/KB2. Oscillation can be controlled by the internal oscillation mode register (RCM).

After a reset release, the internal high-speed oscillator automatically starts oscillation (8 MHz (TYP.)).

5.4.3 Internal low-speed oscillator

The internal low-speed oscillator is incorporated in the 78K0/KB2.

The internal low-speed oscillation clock is only used as the watchdog timer and the clock of 8-bit timer H1. The internal low-speed oscillation clock cannot be used as the CPU clock.

“Can be stopped by software” or “Cannot be stopped” can be selected by the option byte. When “Can be stopped by software” is set, oscillation can be controlled by the internal oscillation mode register (RCM).

After a reset release, the internal low-speed oscillator automatically starts oscillation, and the watchdog timer is driven (240 kHz (TYP.)) if the watchdog timer operation is enabled using the option byte.

5.4.4 Prescaler

The prescaler generates various clocks by dividing the main system clock when the main system clock is selected as the clock to be supplied to the CPU.

5.5 Clock Generator Operation

The clock generator generates the following clocks and controls the operation modes of the CPU, such as standby mode (see **Figure 5-1**).

- Main system clock f_{XP}
 - High-speed system clock f_{XH}
 - X1 clock f_X
 - External main system clock f_{EXCLK}
 - Internal high-speed oscillation clock f_{RH}
- Internal low-speed oscillation clock f_{RL}
- CPU clock f_{CPU}
- Peripheral hardware clock f_{PRS}

The CPU starts operation when the internal high-speed oscillator starts outputting after a reset release in the 78K0/KB2, thus enabling the following.

(1) Enhancement of security function

When the X1 clock is set as the CPU clock by the default setting, the device cannot operate if the X1 clock is damaged or badly connected and therefore does not operate after reset is released. However, the start clock of the CPU is the internal high-speed oscillation clock, so the device can be started by the internal high-speed oscillation clock after a reset release. Consequently, the system can be safely shut down by performing a minimum operation, such as acknowledging a reset source by software or performing safety processing when there is a malfunction.

(2) Improvement of performance

Because the CPU can be started without waiting for the X1 clock oscillation stabilization time, the total performance can be improved.

When the power supply voltage is turned on, the clock generator operation is shown in Figure 5-11.

<R>

**Figure 5-11. Clock Generator Operation When Power Supply Voltage Is Turned On
(When 1.59 V POC Mode Is Set (Option Byte: POCMODE = 0))**

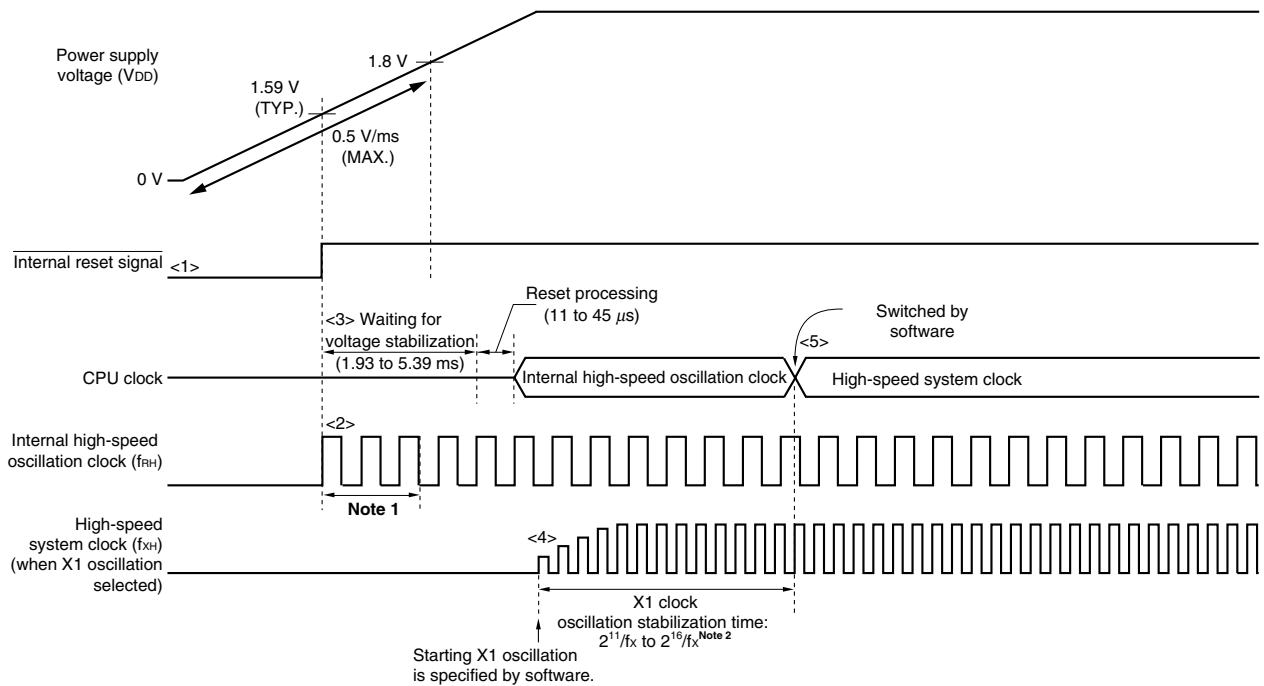

- <1> When the power is turned on, an internal reset signal is generated by the power-on-clear (POC) circuit.
- <2> When the power supply voltage exceeds 1.59 V (TYP.), the reset is released and the internal high-speed oscillator automatically starts oscillation.
- <R> <3> When the power supply voltage rises with a slope of 0.5 V/ms (MIN.), the CPU starts operation on the internal high-speed oscillation clock after the reset is released and after the stabilization times for the voltage of the power supply and regulator have elapsed, and then reset processing is performed.
- <4> Set the start of oscillation of the X1 clock via software (see (1) in 5.6.1 **Example of controlling high-speed system clock**).
- <5> When switching the CPU clock to the X1 clock, wait for the clock oscillation to stabilize, and then set switching via software (see (3) in 5.6.1 **Example of controlling high-speed system clock**).

<R>

- Notes**
- The internal voltage stabilization time includes the oscillation accuracy stabilization time of the internal high-speed oscillation clock.
 - When releasing a reset (above figure) or releasing STOP mode while the CPU is operating on the internal high-speed oscillation clock, confirm the oscillation stabilization time for the X1 clock using the oscillation stabilization time counter status register (OSTC). If the CPU operates on the high-speed system clock (X1 oscillation), set the oscillation stabilization time when releasing STOP mode using the oscillation stabilization time select register (OSTS).

- Cautions**
- If the voltage rises with a slope of less than 0.5 V/ms (MAX.) from power application until the voltage reaches 1.8 V, input a low level to the RESET pin from power application until the voltage reaches 1.8 V, or set the 2.7 V/1.59 V POC mode by using the option byte (POCMODE = 1) (see Figure 5-12). By doing so, the CPU operates with the same timing as <2> and thereafter in Figure 5-11 after reset release by the RESET pin.
 - It is not necessary to wait for the oscillation stabilization time when an external clock input from the EXCLK pin is used.

Remark While the microcontroller is operating, a clock that is not used as the CPU clock can be stopped via software settings. The internal high-speed oscillation clock and high-speed system clock can be stopped by executing the STOP instruction (see (4) in 5.6.1 Example of controlling high-speed system clock, (3) in 5.6.2 Example of controlling internal high-speed oscillation clock).

<R>

**Figure 5-12. Clock Generator Operation When Power Supply Voltage Is Turned On
(When 2.7 V/1.59 V POC Mode Is Set (Option Byte: POCMODE = 1))**

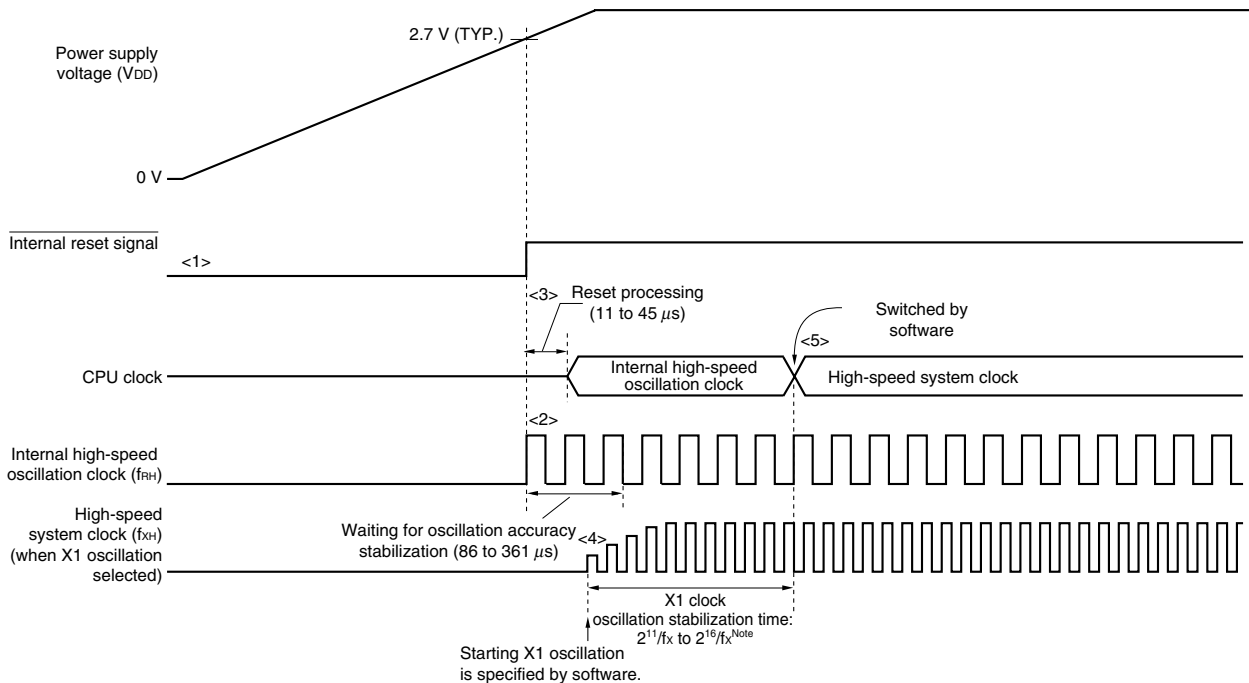

- <1> When the power is turned on, an internal reset signal is generated by the power-on-clear (POC) circuit.
- <2> When the power supply voltage exceeds 2.7 V (TYP.), the reset is released and the internal high-speed oscillator automatically starts oscillation.
- <3> After the reset is released and reset processing is performed, the CPU starts operation on the internal high-speed oscillation clock.
- <4> Set the start of oscillation of the X1 clock via software (see (1) in 5.6.1 Example of controlling high-speed system clock).
- <5> When switching the CPU clock to the X1 clock, wait for the clock oscillation to stabilize, and then set switching via software (see (3) in 5.6.1 Example of controlling high-speed system clock).

Note When releasing a reset (above figure) or releasing STOP mode while the CPU is operating on the internal high-speed oscillation clock, confirm the oscillation stabilization time for the X1 clock using the oscillation stabilization time counter status register (OSTC). If the CPU operates on the high-speed system clock (X1 oscillation), set the oscillation stabilization time when releasing STOP mode using the oscillation stabilization time select register (OSTS).

- <R> **Cautions**
1. A voltage oscillation stabilization time of 1.93 to 5.39 ms is required after the supply voltage reaches 1.59 V (TYP.). If the supply voltage rises from 1.59 V (TYP.) to 2.7 V (TYP.) within 1.93 ms, the power supply oscillation stabilization time of 0 to 5.39 ms is automatically generated before reset processing.
 2. It is not necessary to wait for the oscillation stabilization time when an external clock input from the EXCLK pin is used.

Remark While the microcontroller is operating, a clock that is not used as the CPU clock can be stopped via software settings. The internal high-speed oscillation clock and high-speed system clock can be stopped by executing the STOP instruction (see (4) in 5.6.1 Example of controlling high-speed system clock, (3) in 5.6.2 Example of controlling internal high-speed oscillation clock).

5.6 Controlling Clock

5.6.1 Controlling high-speed system clock

The following two types of high-speed system clocks are available.

- X1 clock: Crystal/ceramic resonator is connected across the X1 and X2 pins.
- External main system clock: External clock is input to the EXCLK pin.

When the high-speed system clock is not used, the X1/P121 and X2/EXCLK/P122 pins can be used as I/O port pins.

Caution The X1/P121 and X2/EXCLK/P122 pins are in the I/O port mode after a reset release.

The following describes examples of setting procedures for the following cases.

- (1) When oscillating X1 clock
- (2) When using external main system clock
- (3) When using high-speed system clock as CPU clock and peripheral hardware clock
- (4) When stopping high-speed system clock

(1) Example of setting procedure when oscillating the X1 clock

<1> Setting frequency (OSCCTL register)

Using AMPH, set the gain of the on-chip oscillator according to the frequency to be used.

AMPH ^{Note}	Operating Frequency Control
0	1 MHz ≤ f _{XH} ≤ 10 MHz
1	10 MHz < f _{XH} ≤ 20 MHz

Note Set AMPH before setting the peripheral functions after a reset release. The value of AMPH can be changed only once after a reset release. When AMPH is set to 1, the clock supply to the CPU is stopped for 4.06 to 16.12 μs.

<R>

Remark f_{XH}: High-speed system clock oscillation frequency

<2> Setting P121/X1 and P122/X2/EXCLK pins and selecting X1 clock or external clock (OSCCTL register)

When EXCLK is cleared to 0 and OSCSEL is set to 1, the mode is switched from port mode to X1 oscillation mode.

EXCLK	OSCSEL	Operation Mode of High-Speed System Clock Pin	P121/X1 Pin	P122/X2/EXCLK Pin
0	1	X1 oscillation mode	Crystal/ceramic resonator connection	

<3> Controlling oscillation of X1 clock (MOC register)

If MSTOP is cleared to 0, the X1 oscillator starts oscillating.

<4> Waiting for the stabilization of the oscillation of X1 clock
 Check the OSTC register and wait for the necessary time.
 During the wait time, other software processing can be executed with the internal high-speed oscillation clock.

- Cautions**
1. Do not change the value of EXCLK and OSCSEL while the X1 clock is operating.
 2. Set the X1 clock after the supply voltage has reached the operable voltage of the clock to be used (see CHAPTER 24 ELECTRICAL SPECIFICATIONS (STANDARD PRODUCTS) or CHAPTER 25 ELECTRICAL SPECIFICATIONS ((A) GRADE PRODUCTS, TARGET)).

(2) Example of setting procedure when using the external main system clock

<1> Setting frequency (OSCCTL register)
 Using AMPH, set the frequency to be used.

AMPH ^{Note}	Operating Frequency Control
0	1 MHz ≤ f _{XH} ≤ 10 MHz
1	10 MHz < f _{XH} ≤ 20 MHz

<R> **Note** Set AMPH before setting the peripheral functions after a reset release. The value of AMPH can be changed only once after a reset release. The clock supply to the CPU is stopped for the duration of 160 external clocks after AMPH is set to 1.

Remark f_{XH}: High-speed system clock oscillation frequency

<2> Setting P121/X1 and P122/X2/EXCLK pins and selecting operation mode (OSCCTL register)
 When EXCLK and OSCSEL are set to 1, the mode is switched from port mode to external clock input mode.

EXCLK	OSCSEL	Operation Mode of High-Speed System Clock Pin	P121/X1 Pin	P122/X2/EXCLK Pin
1	1	External clock input mode	I/O port	External clock input

<3> Controlling external main system clock input (MOC register)
 When MSTOP is cleared to 0, the input of the external main system clock is enabled.

- Cautions**
1. Do not change the value of EXCLK and OSCSEL while the external main system clock is operating.
 2. Set the external main system clock after the supply voltage has reached the operable voltage of the clock to be used (see CHAPTER 24 ELECTRICAL SPECIFICATIONS (STANDARD PRODUCTS) or CHAPTER 25 ELECTRICAL SPECIFICATIONS ((A) GRADE PRODUCTS, TARGET)).

(3) Example of setting procedure when using high-speed system clock as CPU clock and peripheral hardware clock

<1> Setting high-speed system clock oscillation^{Note}
 (See 5.6.1 (1) Example of setting procedure when oscillating the X1 clock and (2) Example of setting procedure when using the external main system clock.)

Note The setting of <1> is not necessary when high-speed system clock is already operating.

<2> Setting the high-speed system clock as the main system clock (MCM register)

When XSEL and MCM0 are set to 1, the high-speed system clock is supplied as the main system clock and peripheral hardware clock.

XSEL	MCM0	Selection of Main System Clock and Clock Supplied to Peripheral Hardware	
		Main System Clock (f_{XP})	Peripheral Hardware Clock (f_{PRS})
1	1	High-speed system clock (f_{XH})	High-speed system clock (f_{XH})

Caution If the high-speed system clock is selected as the main system clock, a clock other than the high-speed system clock cannot be set as the peripheral hardware clock.

<3> Selecting the CPU clock division ratio (PCC register)

To select the CPU clock division ratio, use PCC0, PCC1, and PCC2.

PCC2	PCC1	PCC0	CPU Clock (f_{CPU}) Selection
0	0	0	f_{XP}
0	0	1	$f_{XP}/2$ (default)
0	1	0	$f_{XP}/2^2$
0	1	1	$f_{XP}/2^3$
1	0	0	$f_{XP}/2^1$
Other than above			Setting prohibited

(4) Example of setting procedure when stopping the high-speed system clock

The high-speed system clock can be stopped in the following two ways.

- Executing the STOP instruction and stopping the X1 oscillation (disabling clock input if the external clock is used)
- Setting MSTOP to 1 and stopping the X1 oscillation (disabling clock input if the external clock is used)

(a) To execute a STOP instruction

<1> Setting to stop peripheral hardware

Stop peripheral hardware that cannot be used in the STOP mode (for peripheral hardware that cannot be used in STOP mode, see **CHAPTER 16 STANDBY FUNCTION**).

<2> Setting the X1 clock oscillation stabilization time after standby release

When the CPU is operating on the X1 clock, set the value of the OSTS register before the STOP instruction is executed.

<3> Executing the STOP instruction

When the STOP instruction is executed, the system is placed in the STOP mode and X1 oscillation is stopped (the input of the external clock is disabled).

(b) To stop X1 oscillation (disabling external clock input) by setting MSTOP to 1

<1> Confirming the CPU clock status (MCM registers)

Confirm with MCS that the CPU is operating on a clock other than the high-speed system clock.

When MCS = 1, the high-speed system clock is supplied to the CPU, so change the CPU clock to the internal high-speed oscillation clock.

MCS	CPU Clock Status
0	Internal high-speed oscillation clock
1	High-speed system clock

<2> Stopping the high-speed system clock (MOC register)

When MSTOP is set to 1, X1 oscillation is stopped (the input of the external clock is disabled).

Caution Be sure to confirm that MCS = 0 when setting MSTOP to 1. In addition, stop peripheral hardware that is operating on the high-speed system clock.

5.6.2 Example of controlling internal high-speed oscillation clock

The following describes examples of setting procedures for the following cases.

- (1) When restarting oscillation of the internal high-speed oscillation clock
- (2) When using internal high-speed oscillation clock as CPU clock, and internal high-speed oscillation clock or high-speed system clock as peripheral hardware clock
- (3) When stopping the internal high-speed oscillation clock

(1) Example of setting procedure when restarting oscillation of the internal high-speed oscillation clock^{Note 1}

<1> Setting restart of oscillation of the internal high-speed oscillation clock (RCM register)

When RSTOP is cleared to 0, the internal high-speed oscillation clock starts operating.

<2> Waiting for the oscillation accuracy stabilization time of internal high-speed oscillation clock (RCM register)

Wait until RSTS is set to 1^{Note 2}.

Notes 1. After a reset release, the internal high-speed oscillator automatically starts oscillating and the internal high-speed oscillation clock is selected as the CPU clock.

2. This wait time is not necessary if high accuracy is not necessary for the CPU clock and peripheral hardware clock.

(2) Example of setting procedure when using internal high-speed oscillation clock as CPU clock, or internal high-speed oscillation clock or high-speed system clock as peripheral hardware clock

- <1> • Restarting oscillation of the internal high-speed oscillation clock^{Note}
 (See 5.6.2 (1) **Example of setting procedure when restarting internal high-speed oscillation clock**).
- Oscillating the high-speed system clock^{Note}
 (This setting is required when using the high-speed system clock as the peripheral hardware clock. See 5.6.1 (1) **Example of setting procedure when oscillating the X1 clock** and (2) **Example of setting procedure when using the external main system clock**.)

Note The setting of <1> is not necessary when the internal high-speed oscillation clock or high-speed system clock is already operating.

- <2> Selecting the clock supplied as the main system clock and peripheral hardware clock (MCM register)
 Set the main system clock and peripheral hardware clock using XSEL and MCM0.

XSEL	MCM0	Selection of Main System Clock and Clock Supplied to Peripheral Hardware	
		Main System Clock (f_{XP})	Peripheral Hardware Clock (f_{PRS})
0	0	Internal high-speed oscillation clock (f_{RH})	Internal high-speed oscillation clock (f_{RH})
0	1		High-speed system clock (f_{XH})
1	0		High-speed system clock (f_{XH})

- <3> Selecting the CPU clock division ratio (PCC register)
 To select the CPU clock division ratio, use PCC0, PCC1, and PCC2.

PCC2	PCC1	PCC0	CPU Clock (f_{CPU}) Selection
0	0	0	f_{XP}
0	0	1	$f_{XP}/2$ (default)
0	1	0	$f_{XP}/2^2$
0	1	1	$f_{XP}/2^3$
1	0	0	$f_{XP}/2^4$
Other than above			Setting prohibited

(3) Example of setting procedure when stopping the internal high-speed oscillation clock

The internal high-speed oscillation clock can be stopped in the following two ways.

- Executing the STOP instruction to set the STOP mode
- Setting RSTOP to 1 and stopping the internal high-speed oscillation clock

(a) To execute a STOP instruction

- <1> Setting of peripheral hardware
 Stop peripheral hardware that cannot be used in the STOP mode (for peripheral hardware that cannot be used in STOP mode, see **CHAPTER 16 STANDBY FUNCTION**).
- <2> Setting the X1 clock oscillation stabilization time after standby release
 When the CPU is operating on the X1 clock, set the value of the OSTS register before the STOP instruction is executed.
- <3> Executing the STOP instruction
 When the STOP instruction is executed, the system is placed in the STOP mode and internal high-speed oscillation clock is stopped.

(b) To stop internal high-speed oscillation clock by setting RSTOP to 1

<1> Confirming the CPU clock status (MCM registers)

Confirm with MCS that the CPU is operating on the High-speed system clock.

When MCS = 0, the internal high-speed oscillation clock is supplied to the CPU, so change the CPU clock to the high-speed system clock.

MCS	CPU Clock Status
0	Internal high-speed oscillation clock
1	High-speed system clock

<2> Stopping the internal high-speed oscillation clock (RCM register)

When RSTOP is set to 1, internal high-speed oscillation clock is stopped.

Caution Be sure to confirm that MCS = 1 when setting RSTOP to 1. In addition, stop peripheral hardware that is operating on the internal high-speed oscillation clock.

5.6.3 Example of controlling internal low-speed oscillation clock

The internal low-speed oscillation clock cannot be used as the CPU clock.

Only the following peripheral hardware can operate with this clock.

- Watchdog timer
- 8-bit timer H1 (if f_{RL} is selected as the count clock)

In addition, the following operation modes can be selected by the option byte.

- Internal low-speed oscillator cannot be stopped
- Internal low-speed oscillator can be stopped by software

The internal low-speed oscillator automatically starts oscillation after a reset release, and the watchdog timer is driven (240 kHz (TYP.)) if the watchdog timer operation has been enabled by the option byte.

(1) Example of setting procedure when stopping the internal low-speed oscillation clock

<1> Setting LSRSTOP to 1 (RCM register)

When LSRSTOP is set to 1, the internal low-speed oscillation clock is stopped.

(2) Example of setting procedure when restarting oscillation of the internal low-speed oscillation clock

<1> Clearing LSRSTOP to 0 (RCM register)

When LSRSTOP is cleared to 0, the internal low-speed oscillation clock is restarted.

Caution If “Internal low-speed oscillator cannot be stopped” is selected by the option byte, oscillation of the internal low-speed oscillation clock cannot be controlled.

5.6.4 Clocks supplied to CPU and peripheral hardware

The following table shows the relation among the clocks supplied to the CPU and peripheral hardware, and setting of registers.

Table 5-3. Clocks Supplied to CPU and Peripheral Hardware, and Register Setting

Supplied Clock		XSEL	MCM0	EXCLK
Clock Supplied to CPU	Clock Supplied to Peripheral Hardware			
Internal high-speed oscillation clock		0	×	×
Internal high-speed oscillation clock	X1 clock	1	0	0
	External main system clock	1	0	1
X1 clock		1	1	0
External main system clock		1	1	1

- Remarks**
1. XSEL: Bit 2 of the main clock mode register (MCM)
 2. MCM0: Bit 0 of MCM
 3. EXCLK: Bit 7 of the clock operation mode select register (OSCCTL)
 4. ×: don't care

5.6.5 CPU clock status transition diagram

Figure 5-13 shows the CPU clock status transition diagram of this product.

**Figure 5-13. CPU Clock Status Transition Diagram
(When 1.59 V POC Mode Is Set (Option Byte: POCMODE = 0))**

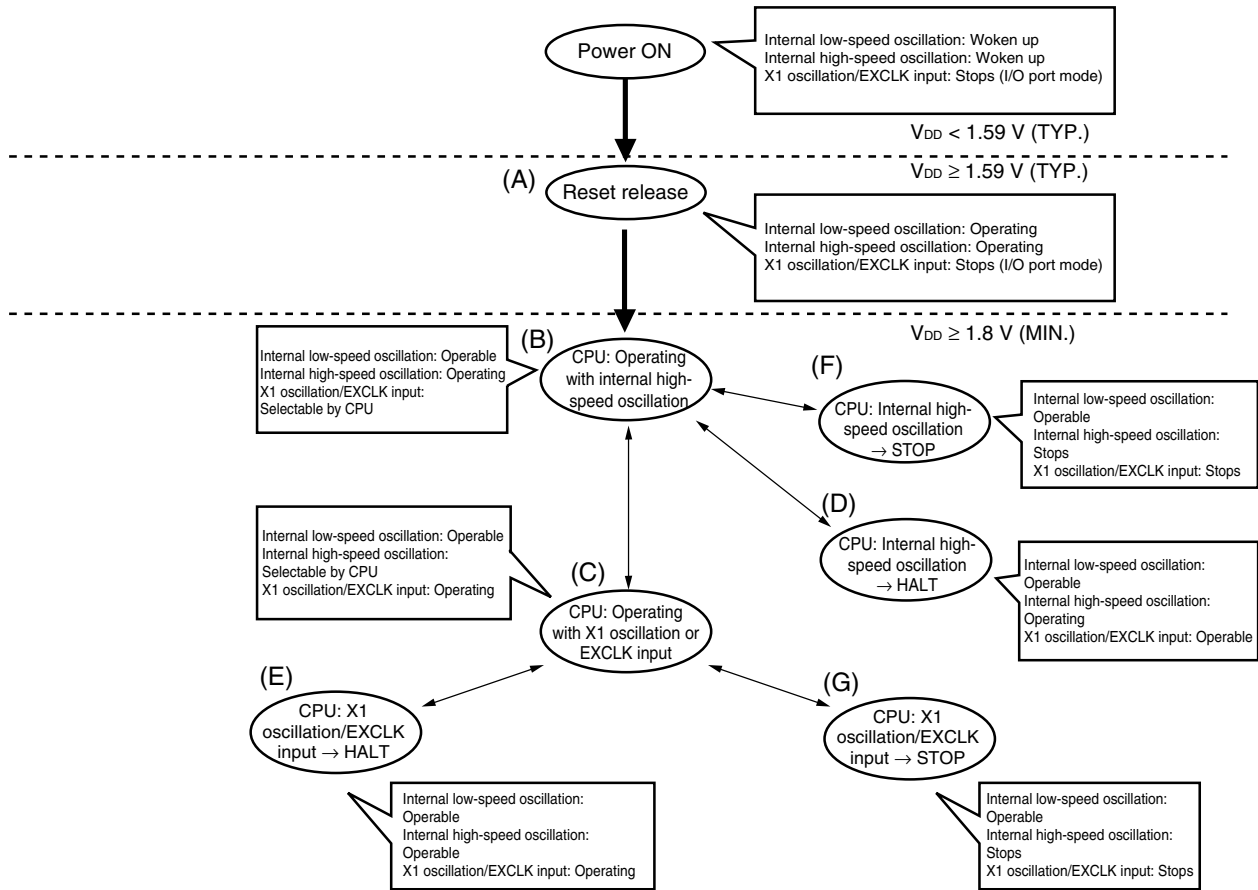

Remark In the 2.7 V/1.59 V POC mode (option byte: POCMODE = 1), the CPU clock status changes to (A) in the above figure when the supply voltage exceeds 2.7 V (TYP.), and to (B) after reset processing (11 to 45 μs).

<R>

Table 5-4 shows transition of the CPU clock and examples of setting the SFR registers.

Table 5-4. CPU Clock Transition and SFR Register Setting Examples (1/3)

(1) CPU operating with internal high-speed oscillation clock (B) after reset release (A)

Status Transition	SFR Register Setting
(A) → (B)	SFR registers do not have to be set (default status after reset release).

(2) CPU operating with high-speed system clock (C) after reset release (A)

(The CPU operates with the internal high-speed oscillation clock immediately after a reset release (B).)

(Setting sequence of SFR registers) →

Setting Flag of SFR Register Status Transition	AMPH	EXCLK	OSCSEL	MSTOP	OSTC Register	XSEL	MCM0
(A) → (B) → (C) (X1 clock: $1 \text{ MHz} \leq f_{XH} \leq 10 \text{ MHz}$)	0	0	1	0	Must be checked	1	1
(A) → (B) → (C) (external main clock: $1 \text{ MHz} \leq f_{XH} \leq 10 \text{ MHz}$)	0	1	1	0	Must not be checked	1	1
(A) → (B) → (C) (X1 clock: $10 \text{ MHz} < f_{XH} \leq 20 \text{ MHz}$)	1	0	1	0	Must be checked	1	1
(A) → (B) → (C) (external main clock: $10 \text{ MHz} < f_{XH} \leq 20 \text{ MHz}$)	1	1	1	0	Must not be checked	1	1

Caution Set the clock after the supply voltage has reached the operable voltage of the clock to be set (see CHAPTER 24 ELECTRICAL SPECIFICATIONS (STANDARD PRODUCTS) or CHAPTER 25 ELECTRICAL SPECIFICATIONS ((A) GRADE PRODUCTS, TARGET)).

Remarks 1. (A) to (G) in Table 5-4 correspond to (A) to (G) in Figure 5-13.

2. EXCLK, OSCSEL, AMPH:

Bits 7, 6, and 0 of the clock operation mode select register (OSCCTL)

MSTOP: Bit 7 of the main OSC control register (MOC)

XSEL, MCM0: Bits 2 and 0 of the main clock mode register (MCM)

×: Don't care

Table 5-4. CPU Clock Transition and SFR Register Setting Examples (2/3)

(3) CPU clock changing from internal high-speed oscillation clock (B) to high-speed system clock (C)

(Setting sequence of SFR registers) →

Setting Flag of SFR Register	AMPH ^{Note}	EXCLK	OSCSEL	MSTOP	OSTC Register	XSEL ^{Note}	MCM0
Status Transition							
(B) → (C) (X1 clock: $1 \text{ MHz} \leq f_{XH} \leq 10 \text{ MHz}$)	0	0	1	0	Must be checked	1	1
(B) → (C) (external main clock: $1 \text{ MHz} \leq f_{XH} \leq 10 \text{ MHz}$)	0	1	1	0	Must not be checked	1	1
(B) → (C) (X1 clock: $10 \text{ MHz} < f_{XH} \leq 20 \text{ MHz}$)	1	0	1	0	Must be checked	1	1
(B) → (C) (external main clock: $10 \text{ MHz} < f_{XH} \leq 20 \text{ MHz}$)	1	1	1	0	Must not be checked	1	1

Unnecessary if these registers are already set
 Unnecessary if the CPU is operating with the high-speed system clock

Note The value of this flag can be changed only once after a reset release. This setting is not necessary if it has already been set.

Caution Set the clock after the supply voltage has reached the operable voltage of the clock to be set (see CHAPTER 24 ELECTRICAL SPECIFICATIONS (STANDARD PRODUCTS) or CHAPTER 25 ELECTRICAL SPECIFICATIONS ((A) GRADE PRODUCTS, TARGET)).

(4) CPU clock changing from high-speed system clock (C) to internal high-speed oscillation clock (B)

(Setting sequence of SFR registers) →

Setting Flag of SFR Register	RSTOP	RSTS	MCM0
Status Transition			
(C) → (B)	0	Confirm this flag is 1.	0

Unnecessary if the CPU is operating with the internal high-speed oscillation clock

Remarks 1. (A) to (G) in Table 5-4 correspond to (A) to (G) in Figure 5-13.

2. EXCLK, OSCSEL, AMPH:

Bits 7, 6, and 0 of the clock operation mode select register (OSCCTL)

MSTOP: Bit 7 of the main OSC control register (MOC)

XSEL, MCM0: Bits 2 and 0 of the main clock mode register (MCM)

RSTS, RSTOP: Bits 7 and 0 of the internal oscillation mode register (RCM)

Table 5-4. CPU Clock Transition and SFR Register Setting Examples (3/3)

- (5) • HALT mode (D) set while CPU is operating with internal high-speed oscillation clock (B)
- HALT mode (E) set while CPU is operating with high-speed system clock (C)

Status Transition	Setting
(B) → (D) (C) → (E)	Executing HALT instruction

- (6) • STOP mode (F) set while CPU is operating with internal high-speed oscillation clock (B)
- STOP mode (G) set while CPU is operating with high-speed system clock (C)

(Setting sequence) →

Status Transition	Setting	
(B) → (F) (C) → (G)	Stopping peripheral functions that cannot operate in STOP mode	Executing STOP instruction

Remark (A) to (G) in Table 5-4 correspond to (A) to (G) in Figure 5-13.

5.6.6 Condition before changing CPU clock and processing after changing CPU clock

Condition before changing the CPU clock and processing after changing the CPU clock are shown below.

Table 5-5. Changing CPU Clock

CPU Clock		Condition Before Change	Processing After Change
Before Change	After Change		
<R> Internal high-speed oscillation clock	X1 clock	Stabilization of X1 oscillation • MSTOP = 0, OSCSEL = 1, EXCLK = 0 • After elapse of oscillation stabilization time	<ul style="list-style-type: none"> • Internal high-speed oscillator can be stopped (RSTOP = 1). • Clock supply to CPU is stopped for 4.06 to 16.12 μs after AMPH has been set to 1.
	External main system clock	Enabling input of external clock from EXCLK pin • MSTOP = 0, OSCSEL = 1, EXCLK = 1	<ul style="list-style-type: none"> • Internal high-speed oscillator can be stopped (RSTOP = 1). • Clock supply to CPU is stopped for the duration of 160 external clocks from the EXCLK pin after AMPH has been set to 1.
X1 clock	Internal high-speed oscillation clock	Oscillation of internal high-speed oscillator • RSTOP = 0	X1 oscillation can be stopped (MSTOP = 1).
External main system clock			External main system clock input can be disabled (MSTOP = 1).

5.6.7 Time required for switchover of main system clock

By setting bits 0 to 2 (PCC0 to PCC2) of the processor clock control register (PCC), the division ratio of the main system clock can be changed.

The actual switchover operation is not performed immediately after rewriting to PCC; operation continues on the pre-switchover clock for several clocks (see **Table 5-6**).

Table 5-6. Time Required for Switchover of CPU Clock and Main System Clock Cycle Division Factor

Set Value Before Switchover			Set Value After Switchover														
PCC2	PCC1	PCC0	PCC2	PCC1	PCC0	PCC2	PCC1	PCC0	PCC2	PCC1	PCC0	PCC2	PCC1	PCC0	PCC2	PCC1	PCC0
			0	0	0	0	0	1	0	1	0	0	1	1	1	0	0
0	0	0	8 clocks			16 clocks			16 clocks			16 clocks			16 clocks		
0	0	1				8 clocks			8 clocks			8 clocks			8 clocks		
0	1	0	4 clocks			4 clocks			4 clocks			4 clocks					
0	1	1	2 clocks			2 clocks			2 clocks			2 clocks					
1	0	0	1 clock			1 clock			1 clock			1 clock					

Remark The number of clocks listed in Table 5-6 is the number of CPU clocks before switchover.

By setting bit 0 (MCM0) of the main clock mode register (MCM), the main system clock can be switched (between the internal high-speed oscillation clock and the high-speed system clock).

The actual switchover operation is not performed immediately after rewriting to MCM0; operation continues on the pre-switchover clock for several clocks (see **Table 5-7**).

Whether the CPU is operating on the internal high-speed oscillation clock or the high-speed system clock can be ascertained using bit 1 (MCS) of MCM.

Table 5-7. Maximum Time Required for Main System Clock Switchover

Set Value Before Switchover	Set Value After Switchover	
MCM0	MCM0	
	0	1
0	1 + 2f _{RH} /f _{XH} clock	
1	1 + 2f _{XH} /f _{RH} clock	

Caution When switching the internal high-speed oscillation clock to the high-speed system clock, bit 2 (XSEL) of MCM must be set to 1 in advance. The value of XSEL can be changed only once after a reset release.

- Remarks**
1. The number of clocks listed in Table 5-7 is the number of main system clocks before switchover.
 2. Calculate the number of clocks in Table 5-7 by removing the decimal portion.

Example When switching the main system clock from the internal high-speed oscillation clock to the high-speed system clock (@ oscillation with f_{RH} = 8 MHz, f_{XH} = 10 MHz)

$$1 + 2f_{RH}/f_{XH} = 1 + 2 \times 8/10 = 1 + 2 \times 0.8 = 1 + 1.6 = 2.6 \rightarrow 2 \text{ clocks}$$

5.6.8 Conditions before clock oscillation is stopped

The following lists the register flag settings for stopping the clock oscillation (disabling external clock input) and conditions before the clock oscillation is stopped.

Table 5-8. Conditions Before the Clock Oscillation Is Stopped and Flag Settings

Clock	Conditions Before Clock Oscillation Is Stopped (External Clock Input Disabled)	Flag Settings of SFR Register
Internal high-speed oscillation clock	MCS = 1 (The CPU is operating on the high-speed system clock)	RSTOP = 1
X1 clock	MCS = 1 (The CPU is operating on the internal high-speed oscillation clock)	MSTOP = 1
External main system clock		

5.6.9 Peripheral hardware and source clocks

The following lists peripheral hardware and source clocks incorporated in the 78K0/KB2.

Table 5-9. Peripheral Hardware and Source Clocks

Source Clock		Peripheral Hardware Clock (f _{PRS})	Internal Low-Speed Oscillation Clock (f _{RL})	TM50 Output	External Clock from Peripheral Hardware Pins
Peripheral Hardware					
16-bit timer/event counter	00	Y	N	N	Y (TI000 pin) ^{Note}
8-bit timer/event counter	50	Y	N	N	Y (TI50 pin) ^{Note}
	51	Y	N	N	Y (TI51 pin) ^{Note}
8-Bit timer	H0	Y	N	Y	N
	H1	Y	Y	N	N
Watchdog timer		N	Y	N	N
A/D converter		Y	N	N	N
Serial interface	UART0	Y	N	Y	N
	UART6	Y	N	Y	N
	CSI10	Y	N	N	Y (SCK10 pin)
	IIC0	Y	N	N	Y (SCL0 pin)

Remark Y: Can be selected, N: Cannot be selected

CHAPTER 6 16-BIT TIMER/EVENT COUNTER 00

6.1 Functions of 16-Bit Timer/Event Counter 00

16-bit timer/event counter 00 has the following functions.

(1) Interval timer

16-bit timer/event counter 00 generates an interrupt request at the preset time interval.

(2) Square-wave output

16-bit timer/event counter 00 can output a square wave with any selected frequency.

(3) External event counter

16-bit timer/event counter 00 can measure the number of pulses of an externally input signal.

(4) One-shot pulse output

16-bit timer event counter 00 can output a one-shot pulse whose output pulse width can be set freely.

(5) PPG output

16-bit timer/event counter 00 can output a rectangular wave whose frequency and output pulse width can be set freely.

(6) Pulse width measurement

16-bit timer/event counter 00 can measure the pulse width of an externally input signal.

6.2 Configuration of 16-Bit Timer/Event Counter 00

16-bit timer/event counter 00 includes the following hardware.

Table 6-1. Configuration of 16-Bit Timer/Event Counter 00

Item	Configuration
Time/counter	16-bit timer counter 00 (TM00)
Register	16-bit timer capture/compare registers 000, 010 (CR000, CR010)
Timer input	TI000, TI010 pins
Timer output	TO00 pin, output controller
Control registers	16-bit timer mode control register 00 (TMC00) 16-bit timer capture/compare control register 00 (CRC00) 16-bit timer output control register 00 (TOC00) Prescaler mode register 00 (PRM00) Port mode register 0 (PM0) Port register 0 (P0)

Figures 6-1 shows the block diagrams.

Figure 6-1. Block Diagram of 16-Bit Timer/Event Counter 00

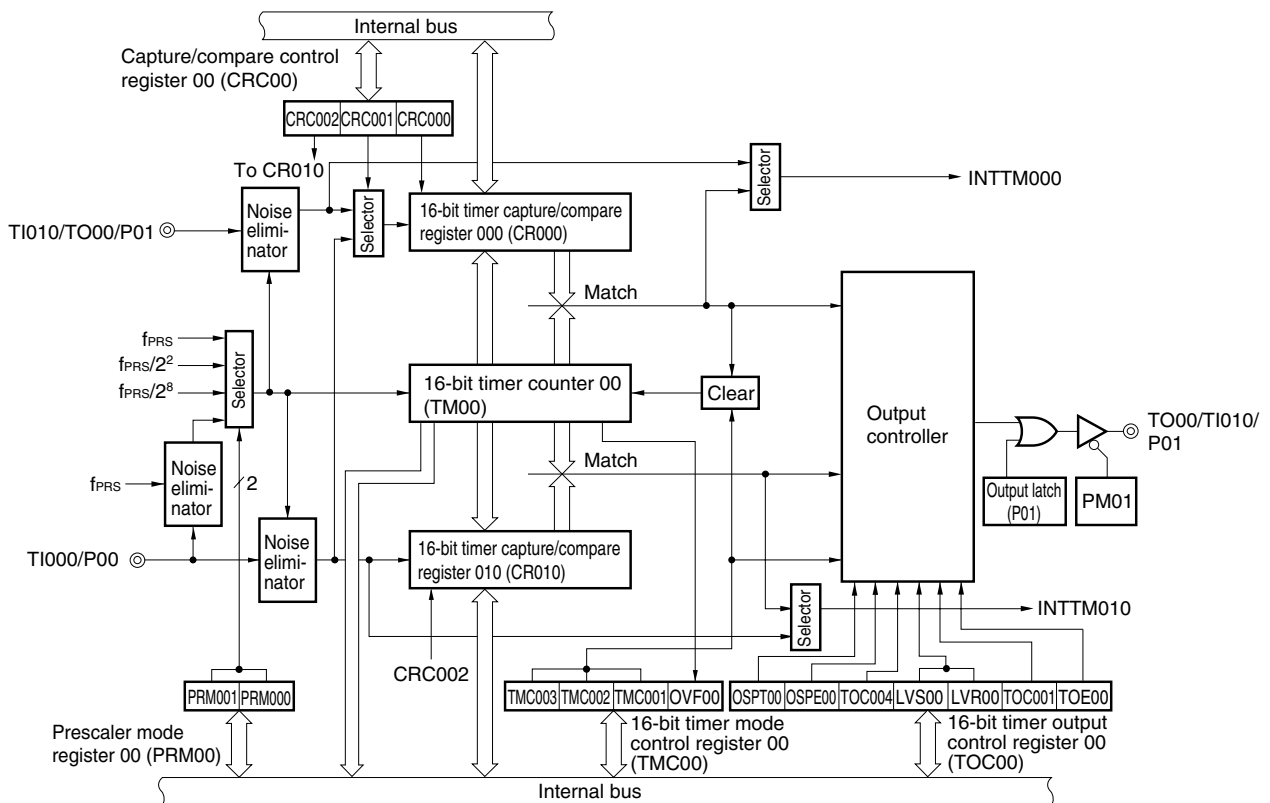

<R>

Cautions 1. The valid edge of TI010 and timer output (TO00) cannot be used for the P01 pin at the same time. Select either of the functions.

Cautions 2. If clearing of bits 3 and 2 (TMC003 and TMC002) of 16-bit timer mode control register 00 (TMC00) to 00 and input of the capture trigger conflict, then the captured data is undefined.

3. To change the mode from the capture mode to the comparison mode, first clear the TMC003 and TMC002 bits to 00, and then change the setting.

A value that has been once captured remains stored in CR000 unless the device is reset. If the mode has been changed to the comparison mode, be sure to set a comparison value.

(1) 16-bit timer counter 00 (TM00)

TM00 is a 16-bit read-only register that counts count pulses.

The counter is incremented in synchronization with the rising edge of the count clock.

If the count value is read during operation, then input of the count clock is temporarily stopped, and the count value at that point is read.

Figure 6-2. Format of 16-Bit Timer Counter 00 (TM00)

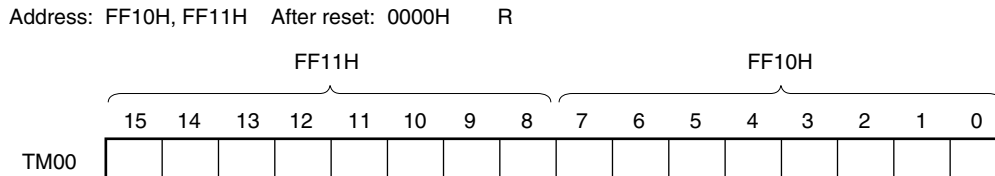

The count value of TM00 can be read by reading TM00 when the value of bits 3 and 2 (TMC003 and TMC002) of 16-bit timer mode control register 00 (TMC00) is other than 00. The value of TM00 is 0000H if it is read when TMC003 and TMC002 = 00.

The count value is reset to 0000H in the following cases.

- At reset signal generation
- If TMC003 and TMC002 are cleared to 00
- If the valid edge of the TI000 pin is input in the mode in which the clear & start occurs when inputting the valid edge to the TI000 pin
- If TM00 and CR000 match in the mode in which the clear & start occurs when TM00 and CR000 match
- OSPT00 is set to 1 in one-shot pulse output mode or the valid edge is input to the TI000 pin

Cautions 1. Even if TM00 is read, the value is not captured by CR010.

2. When TM00 is read, input of the count clock is temporarily stopped and it is resumed after the timer has been read. Therefore, no clock miss occurs.

(2) 16-bit timer capture/compare register 000 (CR000), 16-bit timer capture/compare register 010 (CR010)

CR000 and CR010 are 16-bit registers that are used with a capture function or comparison function selected by using CRC00.

Change the value of CR000 while the timer is stopped (TMC003 and TMC002 = 00).

The value of CR010 can be changed during operation if the value has been set in a specific way. For details, see **6.5.1 Rewriting CR010 during TM00 operation.**

These registers can be read or written in 16-bit units.

Reset signal generation sets these registers to 0000H.

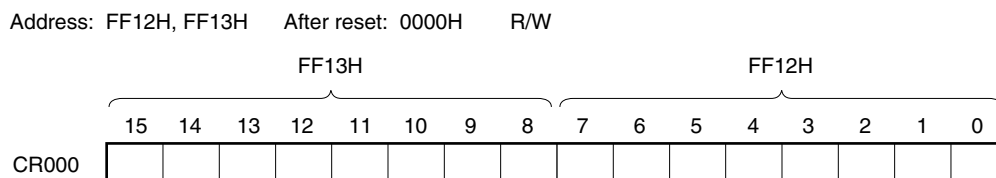
Figure 6-3. Format of 16-Bit Timer Capture/Compare Register 000 (CR000)**(i) When CR000 is used as a compare register**

The value set in CR000 is constantly compared with the TM00 count value, and an interrupt request signal (INTTM000) is generated if they match. The value is held until CR000 is rewritten.

<R>

Caution CR000 does not perform the capture operation when it is set in the comparison mode, even if a capture trigger is input to it.

(ii) When CR000 is used as a capture register

The count value of TM00 is captured to CR000 when a capture trigger is input.

As the capture trigger, an edge of a phase reverse to that of the TI000 pin or the valid edge of the TI010 pin can be selected by using CRC00 or PRM00.

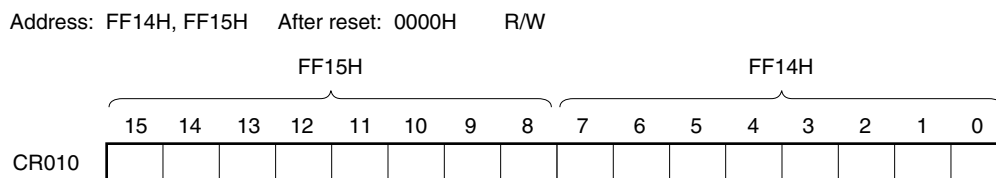
Figure 6-4. Format of 16-Bit Timer Capture/Compare Register 010 (CR010)**(i) When CR010 is used as a compare register**

The value set in CR010 is constantly compared with the TM00 count value, and an interrupt request signal (INTTM010) is generated if they match.

<R>

Caution CR010 does not perform the capture operation when it is set in the comparison mode, even if a capture trigger is input to it.

(ii) When CR010 is used as a capture register

The count value of TM00 is captured to CR010 when a capture trigger is input.

It is possible to select the valid edge of the TI000 pin as the capture trigger. The TI000 pin valid edge is set by PRM00.

<R> (iii) Setting range when CR000 or CR010 is used as a compare register

When CR000 or CR010 is used as a compare register, set it as shown below.

Operation	CR000 Register Setting Range	CR010 Register Setting Range
Operation as interval timer	0000H < N ≤ FFFFH	0000H ^{Note} ≤ M ≤ FFFFH
Operation as square-wave output		Normally, this setting is not used. Mask the match interrupt signal (INTTM010).
Operation as external event counter		
Operation in the clear & start mode entered by TI000 pin valid edge input	0000H ^{Note} ≤ N ≤ FFFFH	0000H ^{Note} ≤ M ≤ FFFFH
Operation as free-running timer		
Operation as PPG output	M < N ≤ FFFFH	0000H ^{Note} ≤ M < N
Operation as one-shot pulse output	0000H ^{Note} ≤ N ≤ FFFFH (N ≠ M)	0000H ^{Note} ≤ M ≤ FFFFH (M ≠ N)





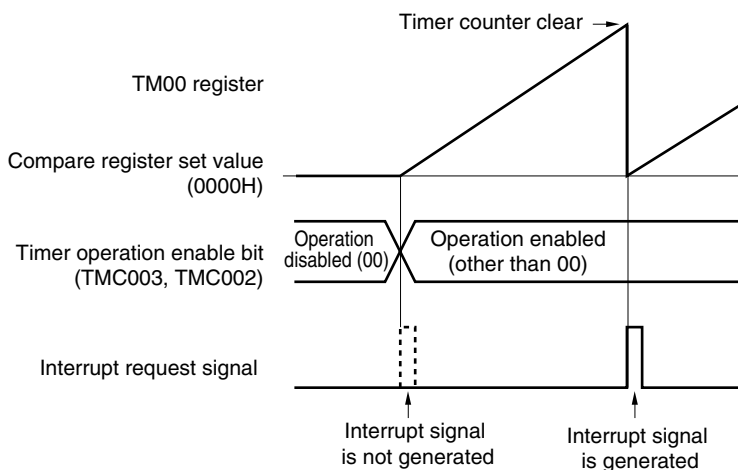

Note When 0000H is set, a match interrupt immediately after the timer operation does not occur and timer output is not changed, and the first match timing is as follows. A match interrupt occurs at the timing when the timer counter (TM00 register) is changed from 0000H to 0001H.

- When the timer counter is cleared due to overflow
- When the timer counter is cleared due to TI000 pin valid edge (when clear & start mode is entered by TI000 pin valid edge input)
- When the timer counter is cleared due to compare match (when clear & start mode is entered by match between TM00 and CR000 (CR000 = other than 0000H, CR010 = 0000H))

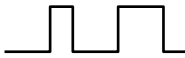

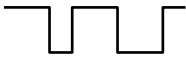
- Remarks**
1. N: CR000 register set value, M: CR010 register set value
 2. For details of TMC003 and TMC002, see 6.3 (1) 16-bit timer mode control register 00 (TMC00).

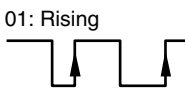
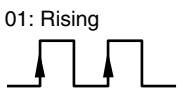
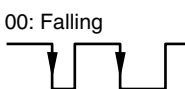
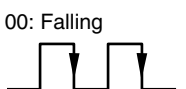
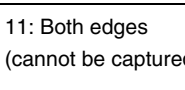
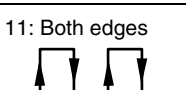
Table 6-2. Capture Operation of CR000 and CR010

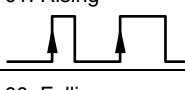
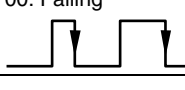
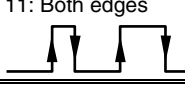
External Input Signal Capture Operation	TI000 Pin Input 		TI010 Pin Input 	
	Capture operation of CR000	CRC001 = 1 TI000 pin input (reverse phase) 	Set values of ES001 and ES000 Position of edge to be captured	CRC001 bit = 0 TI010 pin input 
01: Rising 			01: Rising 	
00: Falling 			00: Falling 	
		11: Both edges (cannot be captured) 		11: Both edges 
	Interrupt signal	INTTM000 signal is not generated even if value is captured.	Interrupt signal	INTTM000 signal is generated each time value is captured.
Capture operation of CR010	TI000 pin input ^{Note} 	Set values of ES001 and ES000 Position of edge to be captured		
		01: Rising 		
		00: Falling 		
		11: Both edges 		
	Interrupt signal	INTTM010 signal is generated each time value is captured.		

Note The capture operation of CR010 is not affected by the setting of the CRC001 bit.

Caution To capture the count value of the TM00 register to the CR000 register by using the phase reverse to that input to the TI000 pin, the interrupt request signal (INTTM000) is not generated after the value has been captured. If the valid edge is detected on the TI010 pin during this operation, the capture operation is not performed but the INTTM000 signal is generated as an external interrupt signal. To not use the external interrupt, mask the INTTM000 signal.

Remark CRC001: See 6.3 (2) Capture/compare control register 00 (CRC00).
ES101, ES100, ES001, ES000: See 6.3 (4) Prescaler mode register 00 (PRM00).

6.3 Registers Controlling 16-Bit Timer/Event Counter 00

Registers used to control 16-bit timer/event counter 00 are shown below.

- 16-bit timer mode control register 00 (TMC00)
- Capture/compare control register 00 (CRC00)
- 16-bit timer output control register 00 (TOC00)
- Prescaler mode register 00 (PRM00)
- Port mode register 0 (PM0)
- Port register 0 (P0)

(1) 16-bit timer mode control register 00 (TMC00)

TMC00 is an 8-bit register that sets the 16-bit timer/event counter 00 operation mode, TM00 clear mode, and output timing, and detects an overflow.

Rewriting TMC00 is prohibited during operation (when TMC003 and TMC002 = other than 00). However, it can be changed when TMC003 and TMC002 are cleared to 00 (stopping operation) and when OVF00 is cleared to 0. TMC00 can be set by a 1-bit or 8-bit memory manipulation instruction.

Reset signal generation sets TMC00 to 00H.

Caution 16-bit timer/event counter 00 starts operation at the moment TMC002 and TMC003 are set to values other than 00 (operation stop mode), respectively. Set TMC002 and TMC003 to 00 to stop the operation.

Figure 6-5. Format of 16-Bit Timer Mode Control Register 00 (TMC00)

Address: FFBAH After reset: 00H R/W

Symbol	7	6	5	4	3	2	1	<0>
TMC00	0	0	0	0	TMC003	TMC002	TMC001	OVF00

<R>

TMC003	TMC002	Operation enable of 16-bit timer/event counter 00
0	0	Disables 16-bit timer/event counter 00 operation. Stops supplying operating clock. Clears 16-bit timer counter 00 (TM00).
0	1	Free-running timer mode
1	0	Clear & start mode entered by TI000 pin valid edge input ^{Note}
1	1	Clear & start mode entered upon a match between TM00 and CR000

TMC001	Condition to reverse timer output (TO00)
0	<ul style="list-style-type: none"> Match between TM00 and CR000 or match between TM00 and CR010
1	<ul style="list-style-type: none"> Match between TM00 and CR000 or match between TM00 and CR010 Trigger input of TI000 pin valid edge

OVF00	TM00 overflow flag
Clear (0)	Clears OVF00 to 0 or TMC003 and TMC002 = 00
Set (1)	Overflow occurs.
<p>OVF00 is set to 1 when the value of TM00 changes from FFFFH to 0000H in all the operation modes (free-running timer mode, clear & start mode entered by TI000 pin valid edge input, and clear & start mode entered upon a match between TM00 and CR000). It can also be set to 1 by writing 1 to OVF00.</p>	

Note The TI000 pin valid edge is set by bits 5 and 4 (ES001, ES000) of prescaler mode register 00 (PRM00).

(2) Capture/compare control register 00 (CRC00)

CRC00 is the register that controls the operation of CR000 and CR010.

Changing the value of CRC00 is prohibited during operation (when TMC003 and TMC002 = other than 00).

CRC00 can be set by a 1-bit or 8-bit memory manipulation instruction.

Reset signal generation clears CRC00 to 00H.

Figure 6-6. Format of Capture/Compare Control Register 00 (CRC00)

Address: FFBC_H After reset: 00_H R/W

Symbol	7	6	5	4	3	2	1	0
CRC00	0	0	0	0	0	CRC002	CRC001	CRC000

CRC002	CR010 operating mode selection
0	Operates as compare register
1	Operates as capture register

CRC001	CR000 capture trigger selection
0	Captures on valid edge of TI010 pin
1	Captures on valid edge of TI000 pin by reverse phase ^{Note}
The valid edge of the TI010 and TI000 pin is set by PRM00. If ES001 and ES000 are set to 11 (both edges) when CRC001 is 1, the valid edge of the TI000 pin cannot be detected.	

CRC000	CR000 operating mode selection
0	Operates as compare register
1	Operates as capture register
If TMC003 and TMC002 are set to 11 (clear & start mode entered upon a match between TM00 and CR000), be sure to set CRC000 to 0.	

Note When the valid edge is detected from the TI010 pin, the capture operation is not performed but the INTTM000 signal is generated as an external interrupt signal.

Caution To ensure that the capture operation is performed properly, the capture trigger requires a pulse two cycles longer than the count clock selected by prescaler mode register 00 (PRM00).

Figure 6-7. Example of CR010 Capture Operation (When Rising Edge Is Specified)

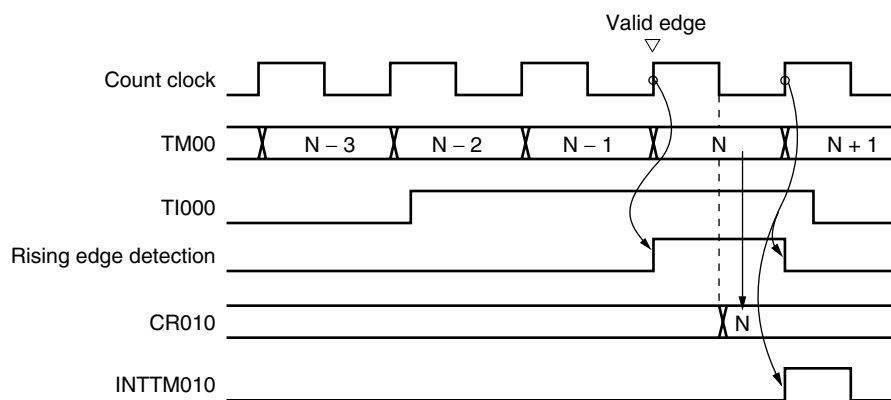
**(3) 16-bit timer output control register 00 (TOC00)**

TOC00 is an 8-bit register that controls the TO00 pin output.

TOC00 can be rewritten while only OSPT00 is operating (when TMC003 and TMC002 = other than 00).

Rewriting the other bits is prohibited during operation.

However, TOC004 can be rewritten during timer operation as a means to rewrite CR010 (see **6.5.1 Rewriting CR010 during TM00 operation**).

TOC00 can be set by a 1-bit or 8-bit memory manipulation instruction.

Reset signal generation clears TOC00 to 00H.

Caution Be sure to set TOC00 using the following procedure.

<1> Set TOC004 and TOC001 to 1.

<2> Set only TOE00 to 1.

<3> Set either of LVS00 or LVR00 to 1.

Figure 6-8. Format of 16-Bit Timer Output Control Register 00 (TOC00)

Address: FFB0H After reset: 00H R/W

Symbol	7	<6>	<5>	4	<3>	<2>	1	<0>
TOC00	0	OSPT00	OSPE00	TOC004	LVS00	LVR00	TOC001	TOE00
OSPT00	One-shot pulse output trigger via software							
0	-							
1	One-shot pulse output							
The value of this bit is always "0" when it is read. Do not set this bit to 1 in a mode other than the one-shot pulse output mode. If it is set to 1, TM00 is cleared and started.								
OSPE00	One-shot pulse output operation control							
0	Successive pulse output							
1	One-shot pulse output							
One-shot pulse output operates correctly in the free-running timer mode or clear & start mode entered by T1000 pin valid edge input. The one-shot pulse cannot be output in the clear & start mode entered upon a match between TM00 and CR000.								
TOC004	TO00 pin output control on match between CR010 and TM00							
0	Disables inversion operation							
1	Enables inversion operation							
The interrupt signal (INTTM010) is generated even when TOC004 = 0.								
LVS00	LVR00	Setting of TO00 pin output status						
0	0	No change						
0	1	Initial value of TO00 pin output is low level (TO00 pin output is cleared to 0).						
1	0	Initial value of TO00 pin output is high level (TO00 pin output is set to 1).						
1	1	Setting prohibited						
<ul style="list-style-type: none"> LVS00 and LVR00 can be used to set the initial value of the output level of the TO00 pin. If the initial value does not have to be set, leave LVS00 and LVR00 as 00. Be sure to set LVS00 and LVR00 when TOE00 = 1. LVS00, LVR00, and TOE00 being simultaneously set to 1 is prohibited. LVS00 and LVR00 are trigger bits. By setting these bits to 1, the initial value of the output level of the TO00 pin can be set. Even if these bits are cleared to 0, output of the TO00 pin is not affected. The values of LVS00 and LVR00 are always 0 when they are read. For how to set LVS00 and LVR00, see 6.5.2 Setting LVS00 and LVR00. 								
TOC001	TO00 pin output control on match between CR000 and TM00							
0	Disables inversion operation							
1	Enables inversion operation							
The interrupt signal (INTTM000) is generated even when TOC001 = 0.								
TOE00	TO00 pin output control							
0	Disables output (TO00 pin output fixed to low level)							
1	Enables output							

(4) Prescaler mode register 00 (PRM00)

PRM00 is the register that sets the TM00 count clock and TI000 and TI010 pin input valid edges.

Rewriting PRM00 is prohibited during operation (when TMC003 and TMC002 = other than 00).

PRM00 can be set by a 1-bit or 8-bit memory manipulation instruction.

Reset signal generation sets PRM00 to 00H.

- Cautions**
1. Do not apply the following setting when setting the PRM001 and PRM000 bits to 11 (to specify the valid edge of the TI000 pin as a count clock).
 - Clear & start mode entered by the TI000 pin valid edge
 - Setting the TI000 pin as a capture trigger
 2. If the operation of the 16-bit timer/event counter 00 is enabled when the TI000 or TI010 pin is at high level and when the valid edge of the TI000 or TI010 pin is specified to be the rising edge or both edges, the high level of the TI000 or TI010 pin is detected as a rising edge. Note this when the TI000 or TI010 pin is pulled up. However, the rising edge is not detected when the timer operation has been once stopped and then is enabled again.
 3. The valid edge of TI010 and timer output (TO00) cannot be used for the P01 pin at the same time. Select either of the functions.

Figure 6-8. Format of Prescaler Mode Register 00 (PRM00)

Address: FFBBH After reset: 00H R/W

Symbol	7	6	5	4	3	2	1	0
PRM00	ES101	ES100	ES001	ES000	0	0	PRM001	PRM000

ES101	ES100	TI010 pin valid edge selection
0	0	Falling edge
0	1	Rising edge
1	0	Setting prohibited
1	1	Both falling and rising edges

ES001	ES000	TI000 pin valid edge selection
0	0	Falling edge
0	1	Rising edge
1	0	Setting prohibited
1	1	Both falling and rising edges

PRM001	PRM000	Count clock selection				
		f_{PRS}	$f_{PRS} = 2 \text{ MHz}$	$f_{PRS} = 5 \text{ MHz}$	$f_{PRS} = 10 \text{ MHz}$	$f_{PRS} = 20 \text{ MHz}$
0	0	f_{PRS}	2 MHz	5 MHz	10 MHz	20 MHz
0	1	$f_{PRS}/2^2$	500 kHz	1.25 MHz	2.5 MHz	5 MHz
1	0	$f_{PRS}/2^8$	7.81 kHz	19.53 kHz	39.06 kHz	78.12 kHz
1	1	TI000 valid edge ^{Note}				

Note The external clock requires a pulse two cycles longer than internal clock (f_{PRS}).

Remark f_{PRS} : Peripheral hardware clock frequency

(5) Port mode register 0 (PM0)

This register sets port 0 input/output in 1-bit units.

When using the P01/TO00/TI010 pin for timer output, set PM01 and the output latches of P01 to 0.

When using the P00/TI000 and P01/TO00/TI010 pins for timer input, set PM00 and PM01 to 1. At this time, the output latches of P00 and P01 may be 0 or 1.

PM0 can be set by a 1-bit or 8-bit memory manipulation instruction.

Reset signal generation sets PM0 to FFH.

Figure 6-10. Format of Port Mode Register 0 (PM0)

Address: FF20H After reset: FFH R/W

Symbol	7	6	5	4	3	2	1	0
PM0	1	1	1	1	1	1	PM01	PM00

PM0n	P0n pin I/O mode selection (n = 0, 1)
0	Output mode (output buffer on)
1	Input mode (output buffer off)

6.4 Operation of 16-Bit Timer/Event Counter 00

6.4.1 Interval timer operation

If bits 3 and 2 (TMC003 and TMC002) of the 16-bit timer mode control register (TMC00) are set to 11 (clear & start mode entered upon a match between TM00 and CR000), the count operation is started in synchronization with the count clock.

When the value of TM00 later matches the value of CR000, TM00 is cleared to 0000H and a match interrupt signal (INTTM000) is generated. This INTTM000 signal enables TM00 to operate as an interval timer.

- Remarks**
1. For the setting of I/O pins, see **6.3 (5) Port mode register 0 (PM0)**.
 2. For how to enable the INTTM000 interrupt, see **CHAPTER 15 INTERRUPT FUNCTIONS**.

Figure 6-11. Block Diagram of Interval Timer Operation

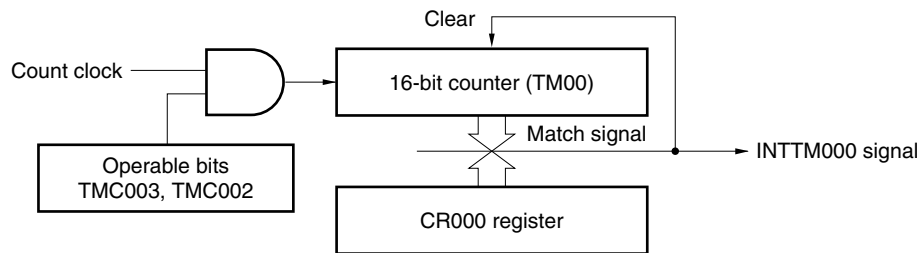

Figure 6-12. Basic Timing Example of Interval Timer Operation

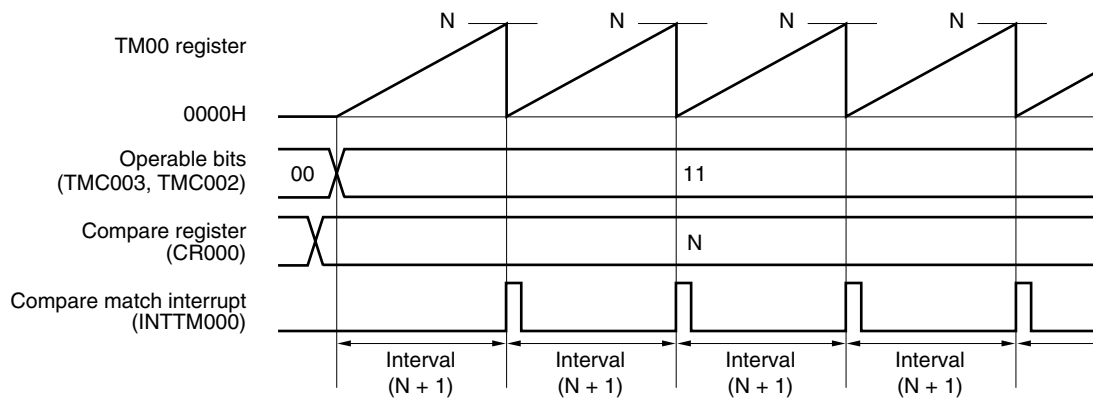
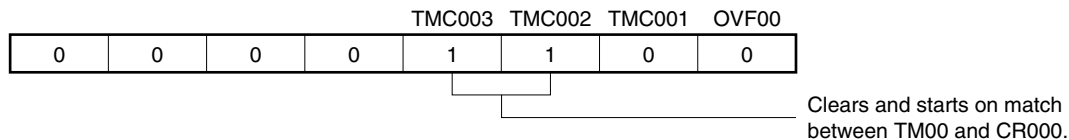
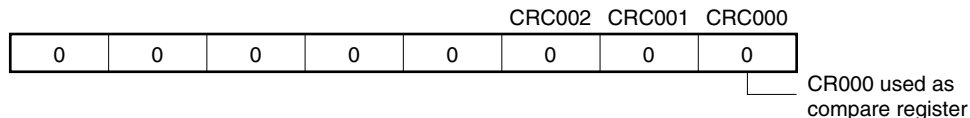

Figure 6-13. Example of Register Settings for Interval Timer Operation

(a) 16-bit timer mode control register 00 (TMC00)



(b) Capture/compare control register 00 (CRC00)



(c) 16-bit timer output control register 00 (TOC00)

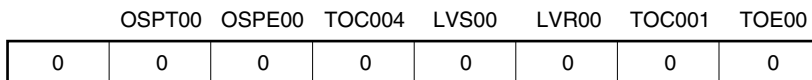

(d) Prescaler mode register 00 (PRM00)

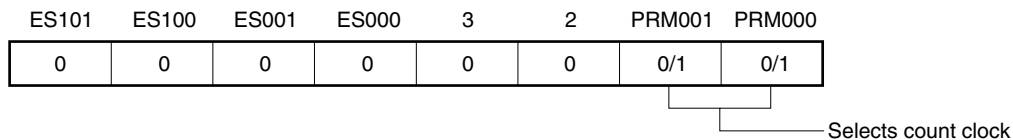

(e) 16-bit timer counter 00 (TM00)

By reading TM00, the count value can be read.

(f) 16-bit capture/compare register 000 (CR000)

If M is set to CR000, the interval time is as follows.

- Interval time = (M + 1) × Count clock cycle

Setting CR000 to 0000H is prohibited.

(g) 16-bit capture/compare register 010 (CR010)

Usually, CR010 is not used for the interval timer function. However, a compare match interrupt (INTTM010) is generated when the set value of CR010 matches the value of TM00.

Therefore, mask the interrupt request by using the interrupt mask flag (TMMK010).

Figure 6-14. Example of Software Processing for Interval Timer Function

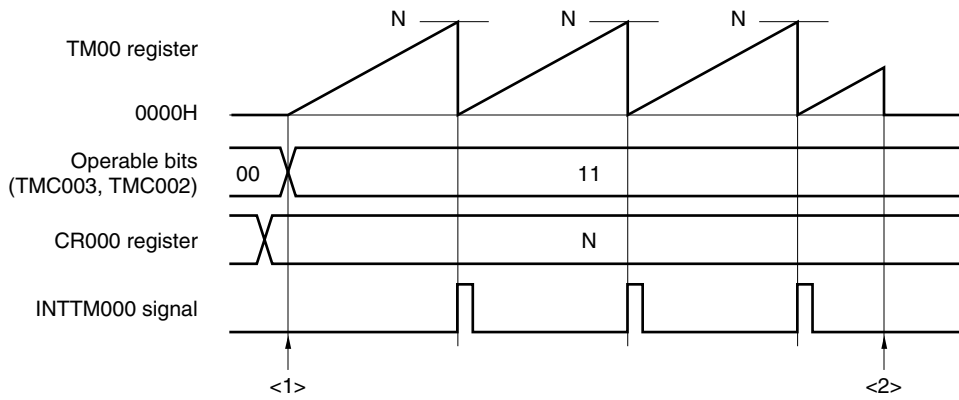

<1> Count operation start flow

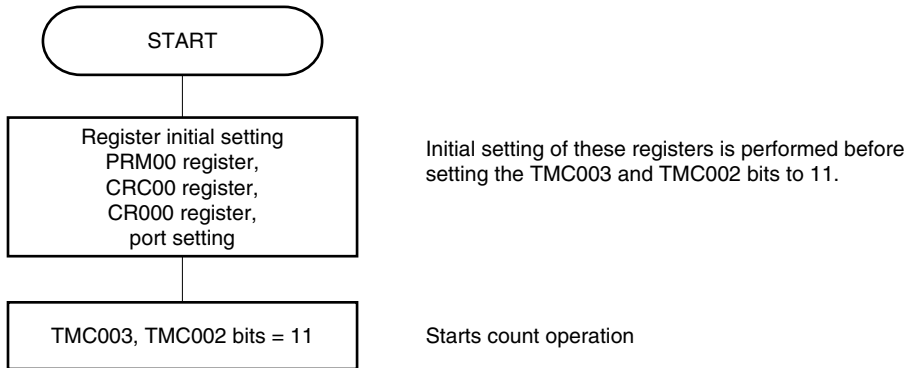

<2> Count operation stop flow

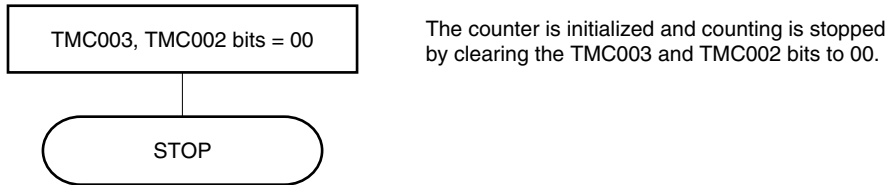

6.4.2 Square wave output operation

When 16-bit timer/event counter 00 operates as an interval timer (see 6.4.1), a square wave can be output from the TO00 pin by setting the 16-bit timer output control register 00 (TOC00) to 03H.

When TMC003 and TMC002 are set to 11 (count clear & start mode entered upon a match between TM00 and CR000), the counting operation is started in synchronization with the count clock.

When the value of TM00 later matches the value of CR000, TM00 is cleared to 0000H, an interrupt signal (INTTM000) is generated, and output of the TO00 pin is inverted. This TO00 pin output that is inverted at fixed intervals enables TO00 to output a square wave.

- Remarks**
1. For the setting of I/O pins, see 6.3 (5) **Port mode register 0 (PM0)**.
 2. For how to enable the INTTM000 signal interrupt, see **CHAPTER 15 INTERRUPT FUNCTIONS**.

Figure 6-15. Block Diagram of Square Wave Output Operation

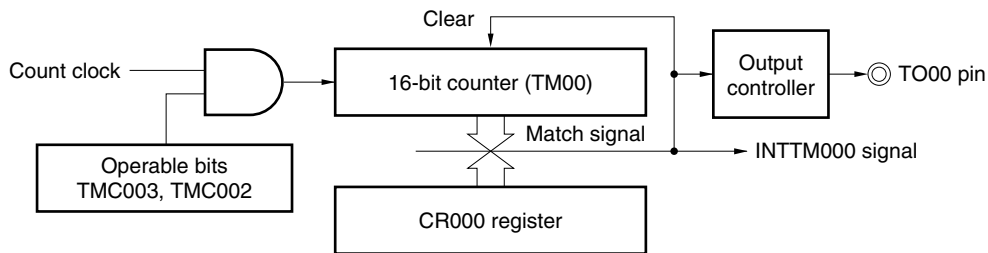

Figure 6-16. Basic Timing Example of Square Wave Output Operation

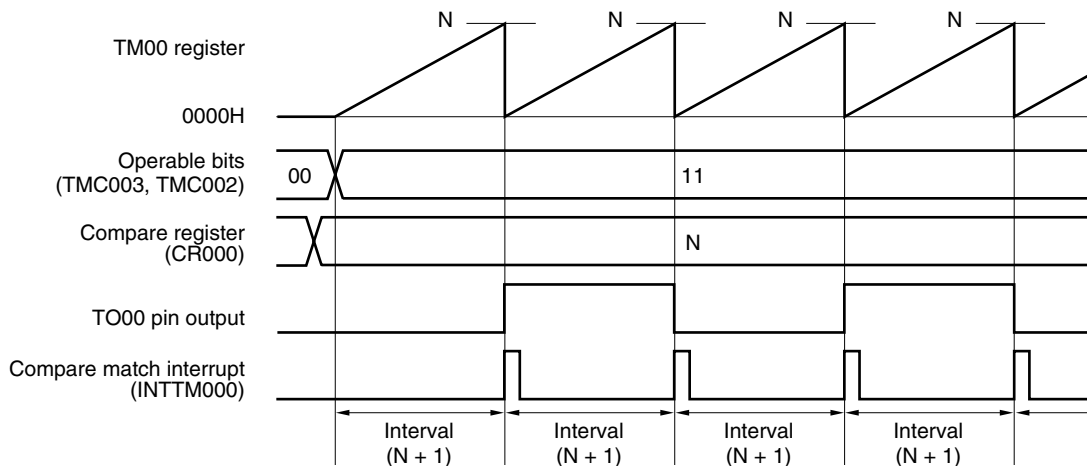
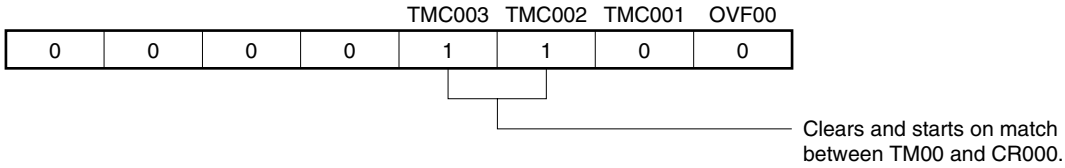
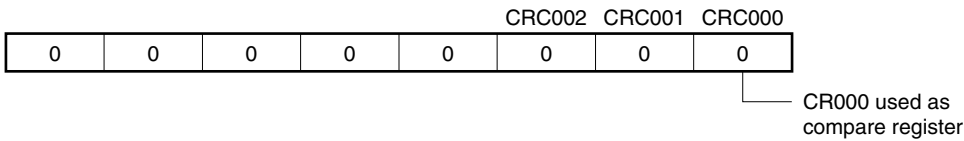

Figure 6-17. Example of Register Settings for Square Wave Output Operation

(a) 16-bit timer mode control register 00 (TMC00)



(b) Capture/compare control register 00 (CRC00)



<R>

(c) 16-bit timer output control register 00 (TOC00)

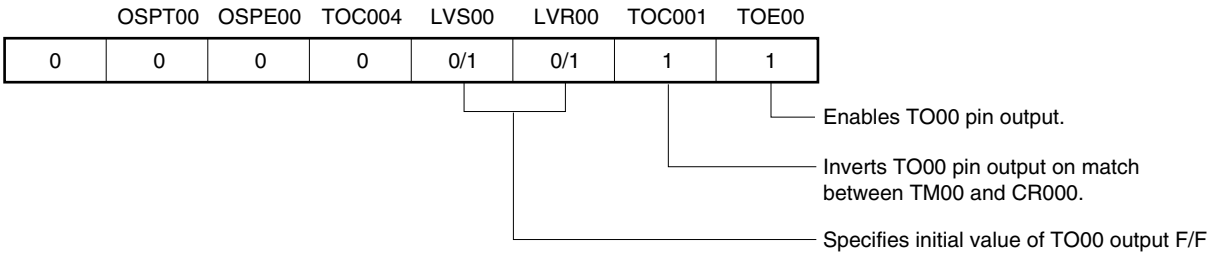

(d) Prescaler mode register 00 (PRM00)

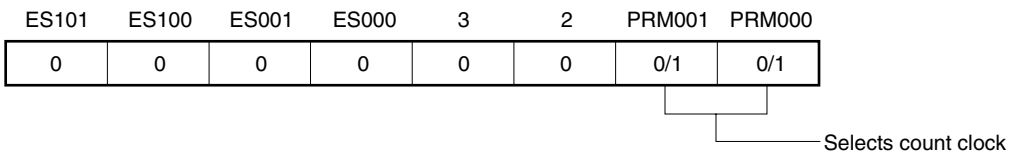

(e) 16-bit timer counter 00 (TM00)

By reading TM00, the count value can be read.

(f) 16-bit capture/compare register 000 (CR000)

If M is set to CR000, the interval time is as follows.

- Square wave frequency = $1 / [2 \times (M + 1) \times \text{Count clock cycle}]$

Setting CR000 to 0000H is prohibited.

(g) 16-bit capture/compare register 010 (CR010)

Usually, CR010 is not used for the square wave output function. However, a compare match interrupt (INTTM010) is generated when the set value of CR010 matches the value of TM00.

Therefore, mask the interrupt request by using the interrupt mask flag (TMMK010).

<R>

Figure 6-18. Example of Software Processing for Square Wave Output Function

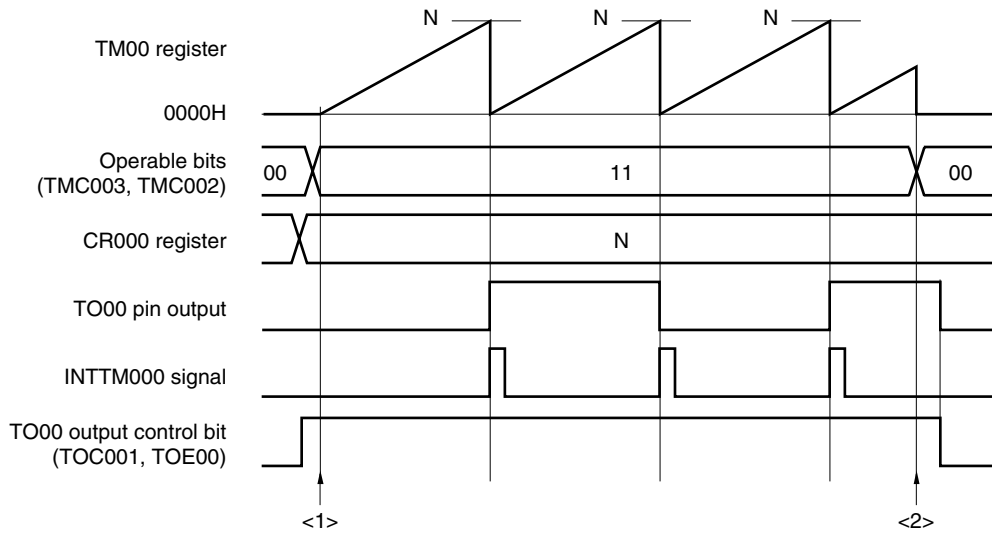

<1> Count operation start flow

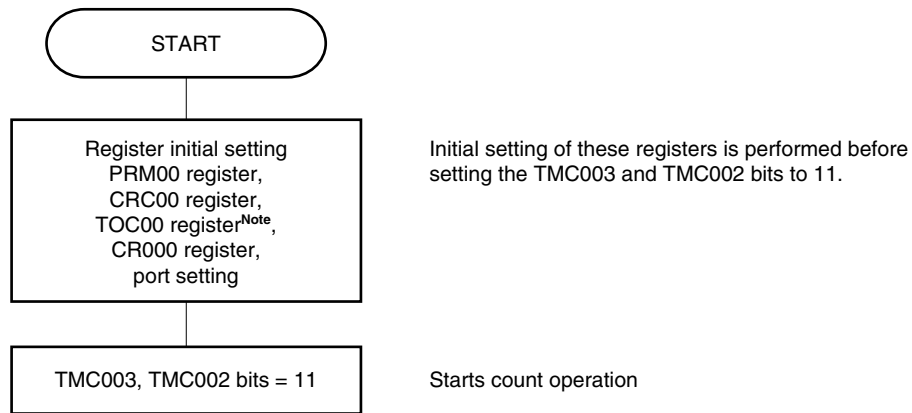

<2> Count operation stop flow

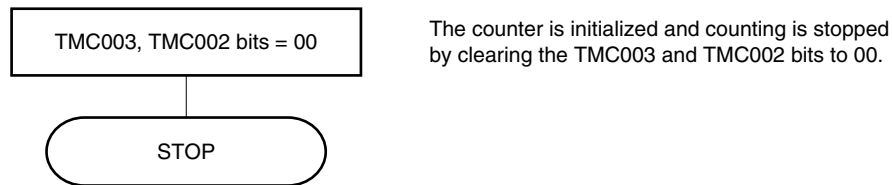

Note Care must be exercised when setting TOC00. For details, see 6.3 (3) 16-bit timer output control register 00 (TOC00).

6.4.3 External event counter operation

When bits 1 and 0 (PRM001 and PRM000) of the prescaler mode register 00 (PRM00) are set to 11 (for counting up with the valid edge of the TI000 pin) and bits 3 and 2 (TMC003 and TMC002) of 16-bit timer mode control register 00 (TMC00) are set to 11, the valid edge of an external event input is counted, and a match interrupt signal indicating matching between TM00 and CR000 (INTTM000) is generated.

To input the external event, the TI000 pin is used. Therefore, the timer/event counter cannot be used as an external event counter in the clear & start mode entered by the TI000 pin valid edge input (when TMC003 and TMC002 = 10).

The INTTM000 signal is generated with the following timing.

- Timing of generation of INTTM000 signal (second time or later)
= Number of times of detection of valid edge of external event \times (Set value of CR000 + 1)

However, the first match interrupt immediately after the timer/event counter has started operating is generated with the following timing.

- Timing of generation of INTTM000 signal (first time only)
= Number of times of detection of valid edge of external event input \times (Set value of CR000 + 2)

To detect the valid edge, the signal input to the TI000 pin is sampled during the clock cycle of f_{PRS} . The valid edge is not detected until it is detected two times in a row. Therefore, a noise with a short pulse width can be eliminated.

Remarks 1. For the setting of I/O pins, see **6.3 (5) Port mode register 0 (PM0)**.

2. For how to enable the INTTM000 signal interrupt, see **CHAPTER 15 INTERRUPT FUNCTIONS**.

Figure 6-19. Block Diagram of External Event Counter Operation

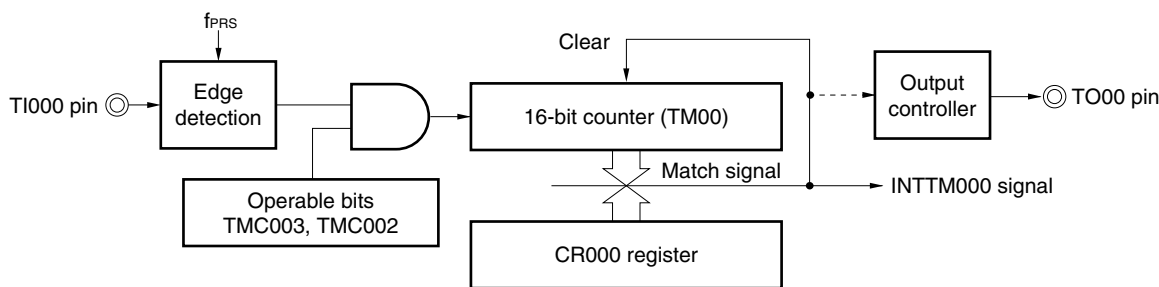
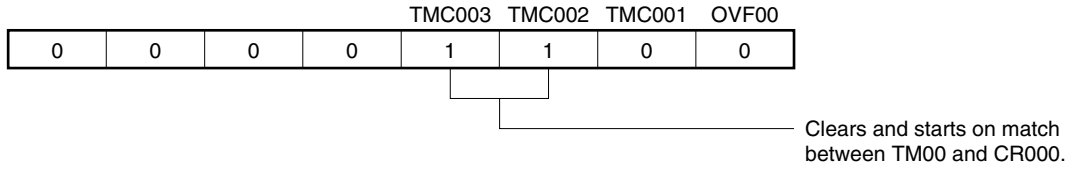
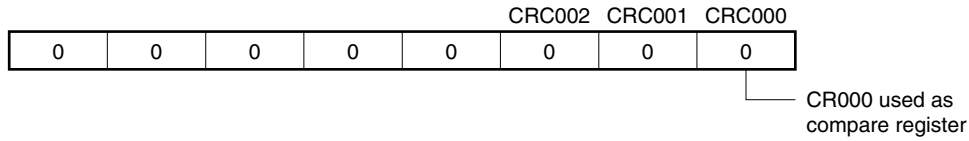

Figure 6-20. Example of Register Settings in External Event Counter Mode

(a) 16-bit timer mode control register 00 (TMC00)



(b) Capture/compare control register 00 (CRC00)



<R> (c) 16-bit timer output control register 00 (TOC00)

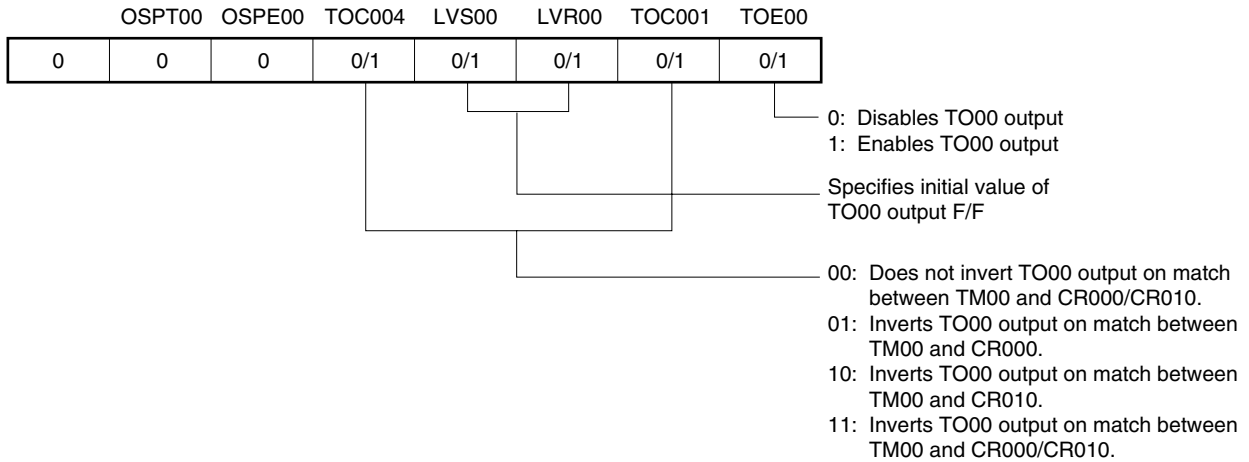

(d) Prescaler mode register 00 (PRM00)

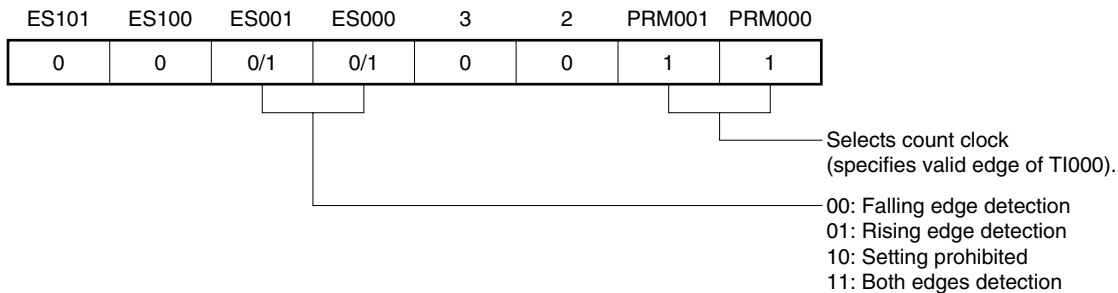

(e) 16-bit timer counter 00 (TM00)

By reading TM00, the count value can be read.

(f) 16-bit capture/compare register 000 (CR000)

If M is set to CR000, the interrupt signal (INTTM000) is generated when the number of external events reaches (M + 1).

Setting CR000 to 0000H is prohibited.

(g) 16-bit capture/compare register 010 (CR010)

Usually, CR010 is not used in the external event counter mode. However, a compare match interrupt (INTTM010) is generated when the set value of CR010 matches the value of TM00.

Therefore, mask the interrupt request by using the interrupt mask flag (TMMK010).

<R>

Figure 6-21. Example of Software Processing in External Event Counter Mode

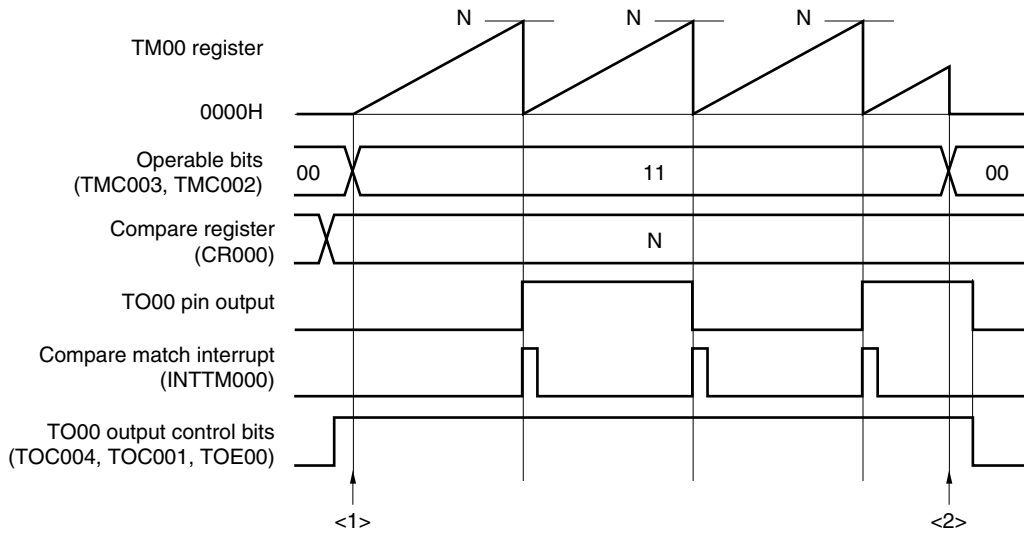

<1> Count operation start flow

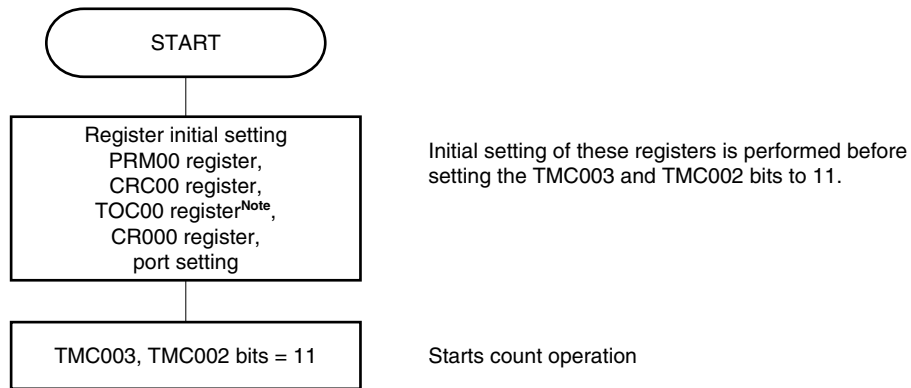

<2> Count operation stop flow

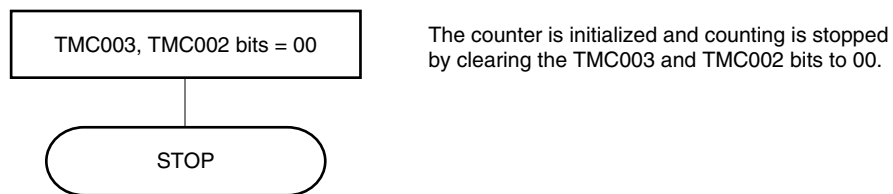

Note Care must be exercised when setting TOC00. For details, see 6.3 (3) 16-bit timer output control register 00 (TOC00).

6.4.4 Operation in clear & start mode entered by TI000 pin valid edge input

When bits 3 and 2 (TMC003 and TMC002) of 16-bit timer mode control register 00 (TMC00) are set to 10 (clear & start mode entered by the TI000 pin valid edge input) and the count clock (set by PRM00) is supplied to the timer/event counter, TM00 starts counting up. When the valid edge of the TI000 pin is detected during the counting operation, TM00 is cleared to 0000H and starts counting up again. If the valid edge of the TI000 pin is not detected, TM00 overflows and continues counting.

The valid edge of the TI000 pin is a cause to clear TM00. Starting the counter is not controlled immediately after the start of the operation.

CR000 and CR010 are used as compare registers and capture registers.

(a) When CR000 and CR010 are used as compare registers

Signals INTTM000 and INTTM010 are generated when the value of TM00 matches the value of CR000 and CR010.

(b) When CR000 and CR010 are used as capture registers

The count value of TM00 is captured to CR000 and the INTTM000 signal is generated when the valid edge is input to the TI010 pin (or when the phase reverse to that of the valid edge is input to the TI000 pin).

When the valid edge is input to the TI000 pin, the count value of TM00 is captured to CR010 and the INTTM010 signal is generated. As soon as the count value has been captured, the counter is cleared to 0000H.

Caution Do not set the count clock as the valid edge of the TI000 pin (PRM001 and PRM000 = 11). When PRM001 and PRM000 = 11, TM00 is cleared.

Remarks 1. For the setting of the I/O pins, see 6.3 (5) Port mode register 0 (PM0).

2. For how to enable the INTTM000 signal interrupt, see CHAPTER 15 INTERRUPT FUNCTIONS.

(1) Operation in clear & start mode entered by TI000 pin valid edge input (CR000: compare register, CR010: compare register)

**Figure 6-22. Block Diagram of Clear & Start Mode Entered by TI000 Pin Valid Edge Input
(CR000: Compare Register, CR010: Compare Register)**

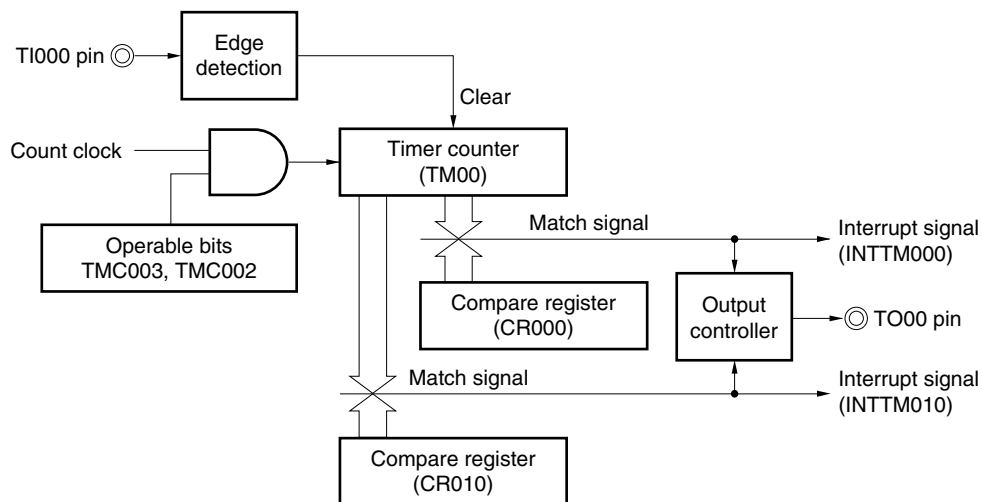
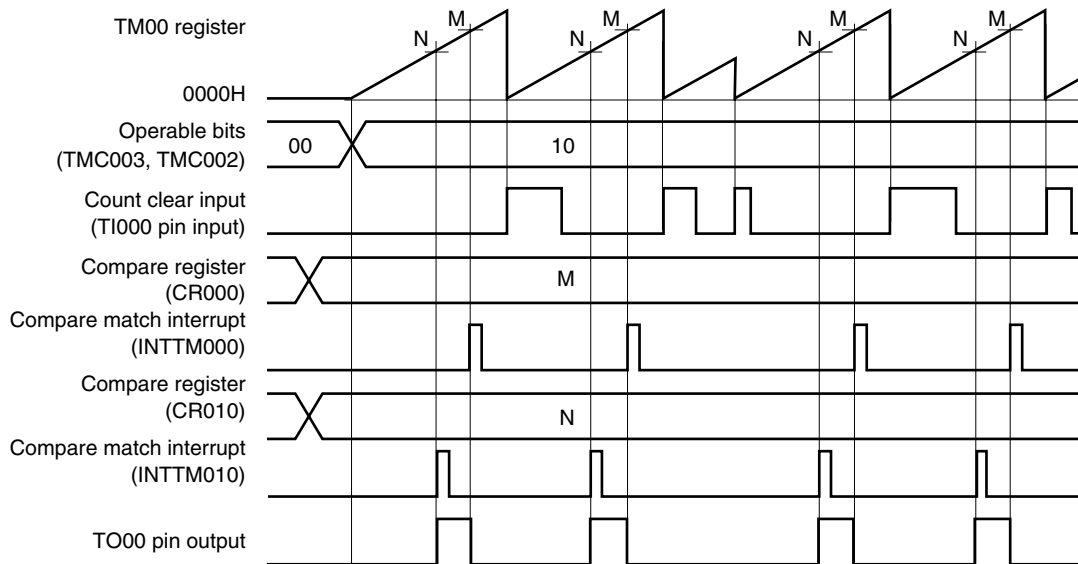
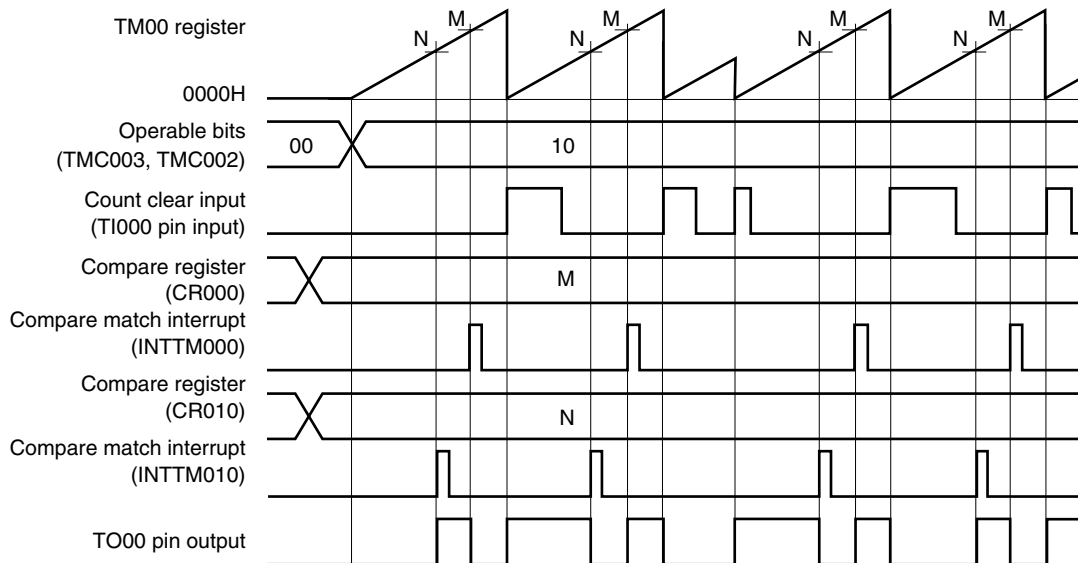

Figure 6-23. Timing Example of Clear & Start Mode Entered by TI000 Pin Valid Edge Input (CR000: Compare Register, CR010: Compare Register)

(a) TOC00 = 13H, PRM00 = 10H, CRC00, = 00H, TMC00 = 08H



(b) TOC00 = 13H, PRM00 = 10H, CRC00, = 00H, TMC00 = 0AH



(a) and (b) differ as follows depending on the setting of bit 1 (TMC001) of the 16-bit timer mode control register 01 (TMC00).

- (a) The output level of the TO00 pin is inverted when TM00 matches a compare register.
- (b) The output level of the TO00 pin is inverted when TM00 matches a compare register or when the valid edge of the TI000 pin is detected.

(2) Operation in clear & start mode entered by TI000 pin valid edge input
(CR000: compare register, CR010: capture register)

Figure 6-24. Block Diagram of Clear & Start Mode Entered by TI000 Pin Valid Edge Input
(CR000: Compare Register, CR010: Capture Register)

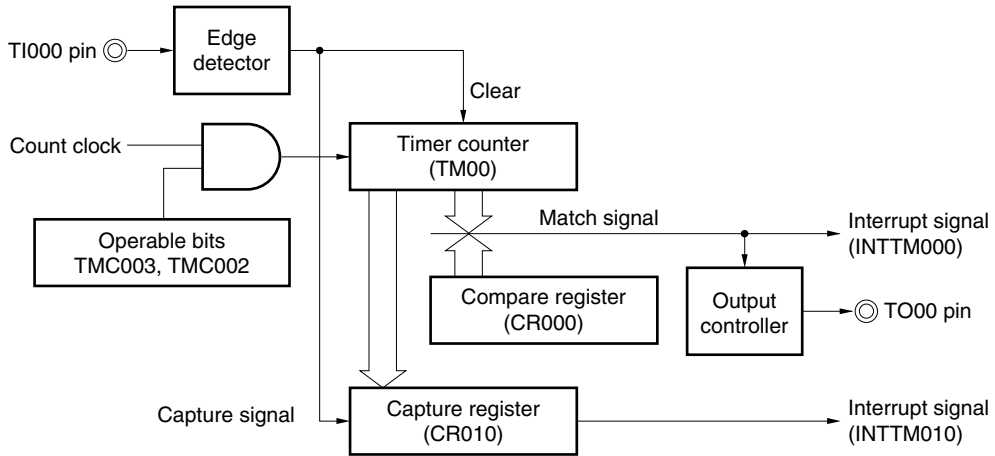
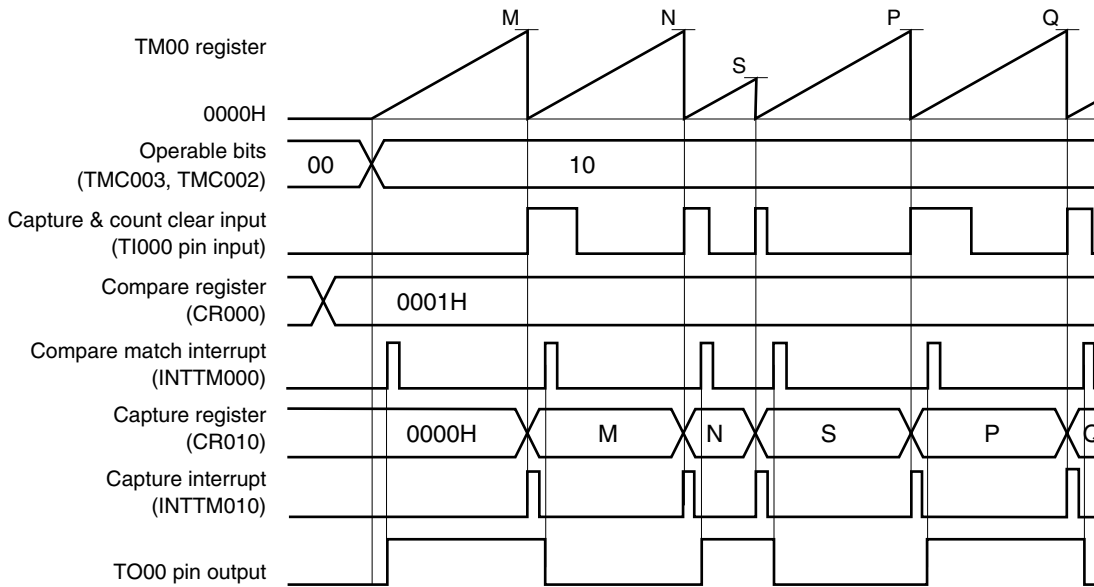

Figure 6-25. Timing Example of Clear & Start Mode Entered by TI000 Pin Valid Edge Input
(CR000: Compare Register, CR010: Capture Register) (1/2)

(a) TOC00 = 13H, PRM00 = 10H, CRC00, = 04H, TMC00 = 08H, CR000 = 0001H



This is an application example where the output level of the TO00 pin is inverted when the count value has been captured & cleared.

The count value is captured to CR010 and TM00 is cleared (to 0000H) when the valid edge of the TI000 pin is detected. When the count value of TM00 is 0001H, a compare match interrupt signal (INTTM000) is generated, and the output level of the TO00 pin is inverted.

**Figure 6-25. Timing Example of Clear & Start Mode Entered by TI000 Pin Valid Edge Input
(CR000: Compare Register, CR010: Capture Register) (2/2)**

(b) TOC00 = 13H, PRM00 = 10H, CRC00, = 04H, TMC00 = 0AH, CR000 = 0003H

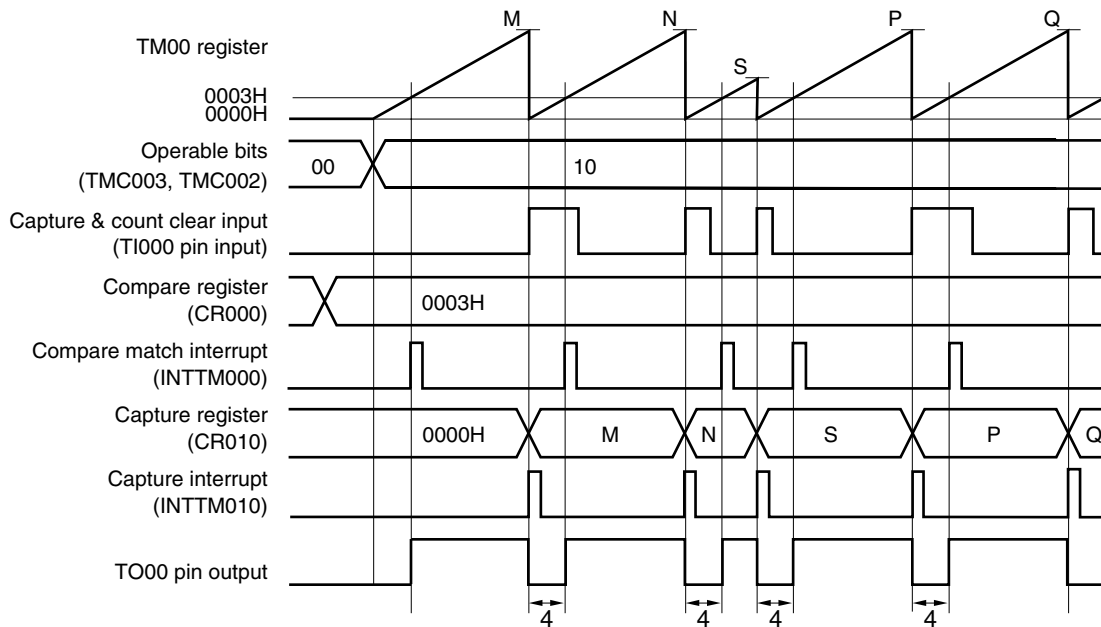

This is an application example where the width set to CR000 (4 clocks in this example) is to be output from the TO00 pin when the count value has been captured & cleared.

The count value is captured to CR010, a capture interrupt signal (INTTM010) is generated, TM00 is cleared (to 0000H), and the output level of the TO00 pin is inverted when the valid edge of the TI000 pin is detected. When the count value of TM00 is 0003H (four clocks have been counted), a compare match interrupt signal (INTTM000) is generated and the output level of the TO00 pin is inverted.

(3) Operation in clear & start mode by entered T1000 pin valid edge input
(CR000: capture register, CR010: compare register)

Figure 6-26. Block Diagram of Clear & Start Mode Entered by T1000 Pin Valid Edge Input
(CR000: Capture Register, CR010: Compare Register)

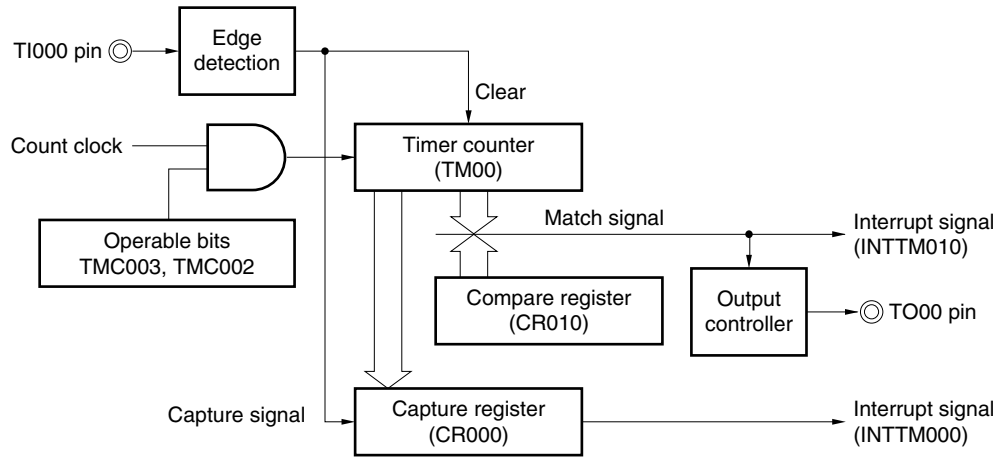

**Figure 6-27. Timing Example of Clear & Start Mode Entered by TI000 Pin Valid Edge Input
(CR000: Capture Register, CR010: Compare Register) (1/2)**

(a) TOC00 = 13H, PRM00 = 10H, CRC00, = 03H, TMC00 = 08H, CR010 = 0001H

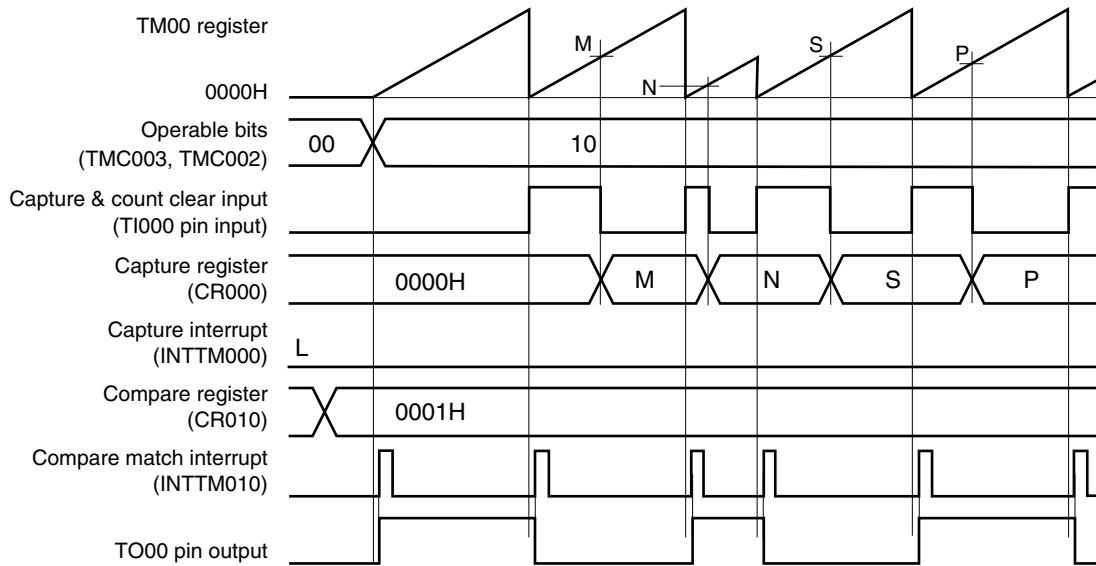

This is an application example where the output level of the TO00 pin is to be inverted when the count value has been captured & cleared.

TM00 is cleared at the rising edge detection of the TI000 pin and it is captured to CR000 at the falling edge detection of the TI000 pin.

When bit 1 (CRC001) of capture/compare control register 00 (CRC00) is set to 1, the count value of TM00 is captured to CR000 in the phase reverse to that of the signal input to the TI000 pin, but the capture interrupt signal (INTTM000) is not generated. However, the INTTM000 signal is generated when the valid edge of the TI010 pin is detected. Mask the INTTM000 signal when it is not used.

Figure 6-27. Timing Example of Clear & Start Mode Entered by TI000 Pin Valid Edge Input (CR000: Capture Register, CR010: Compare Register) (2/2)

(b) TOC00 = 13H, PRM00 = 10H, CRC00, = 03H, TMC00 = 0AH, CR010 = 0003H

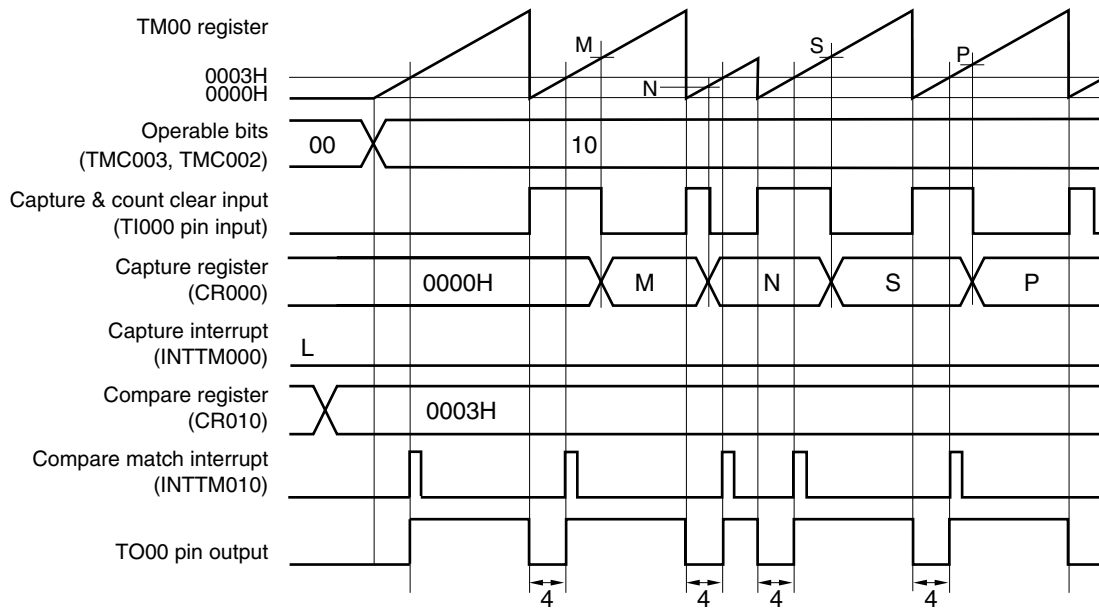

This is an application example where the width set to CR010 (4 clocks in this example) is to be output from the TO00 pin when the count value has been captured & cleared.

TM00 is cleared (to 0000H) at the rising edge detection of the TI000 pin and captured to CR000 at the falling edge detection of the TI000 pin. The output level of the TO00 pin is inverted when TM00 is cleared (to 0000H) because the rising edge of the TI000 pin has been detected or when the value of TM00 matches that of a compare register (CR010).

When bit 1 (CRC001) of capture/compare control register 00 (CRC00) is 1, the count value of TM00 is captured to CR000 in the phase reverse to that of the input signal of the TI000 pin, but the capture interrupt signal (INTTM000) is not generated. However, the INTTM000 interrupt is generated when the valid edge of the TI010 pin is detected. Mask the INTTM000 signal when it is not used.

(4) Operation in clear & start mode entered by TI000 pin valid edge input
(CR000: capture register, CR010: capture register)

Figure 6-28. Block Diagram of Clear & Start Mode Entered by TI000 Pin Valid Edge Input
(CR000: Capture Register, CR010: Capture Register)

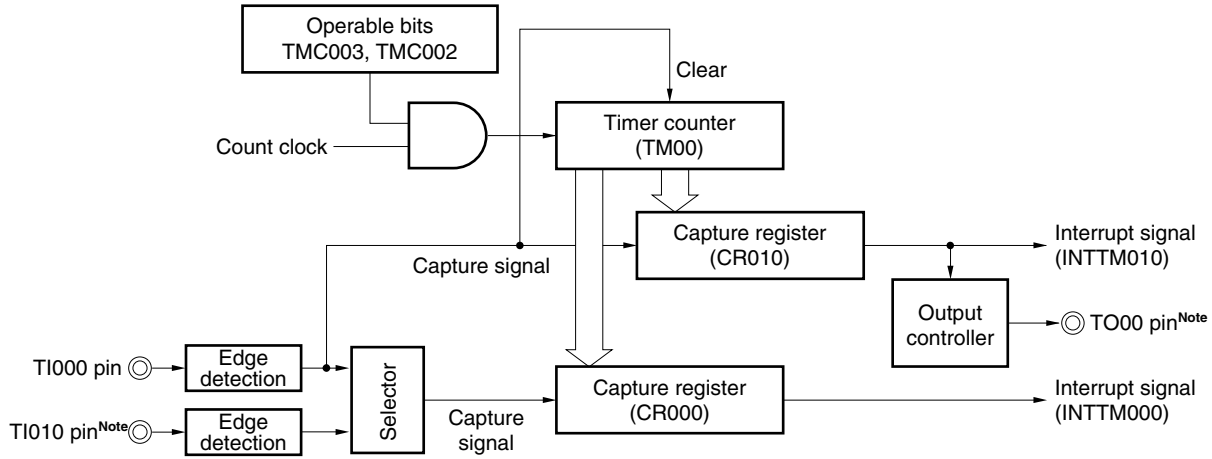

Note The timer output (TO00) cannot be used when detecting the valid edge of the TI010 pin is used.

Figure 6-29. Timing Example of Clear & Start Mode Entered by TI000 Pin Valid Edge Input
(CR000: Capture Register, CR010: Capture Register) (1/3)

(a) TOC00 = 13H, PRM00 = 30H, CRC00 = 05H, TMC00 = 0AH

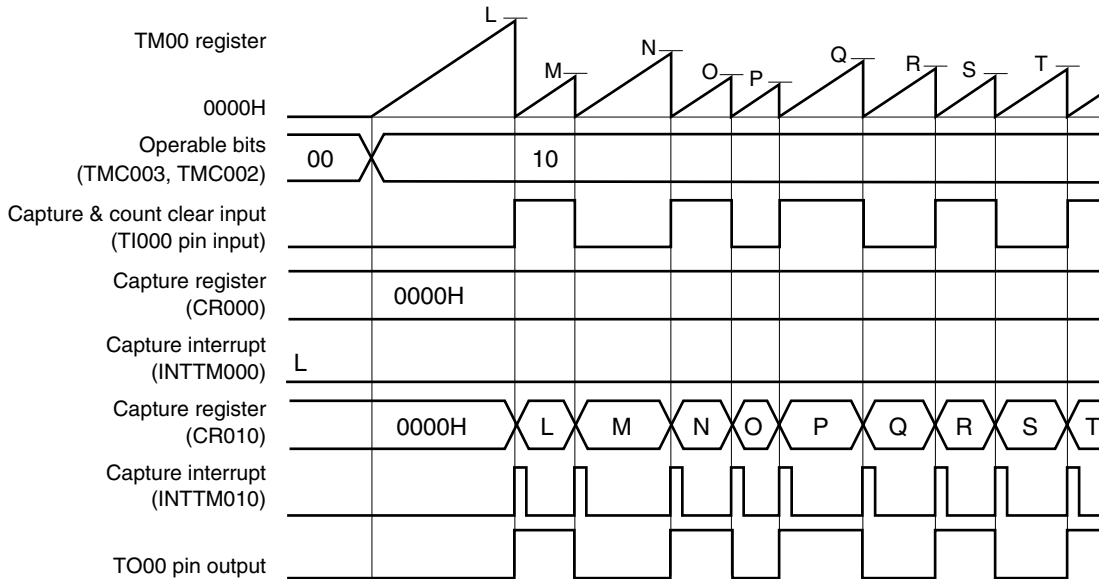

This is an application example where the count value is captured to CR010, TM00 is cleared, and the TO00 pin output is inverted when the rising or falling edge of the TI000 pin is detected.

When the edge of the TI010 pin is detected, an interrupt signal (INTTM000) is generated. Mask the INTTM000 signal when it is not used.

Figure 6-29. Timing Example of Clear & Start Mode Entered by TI000 Pin Valid Edge Input (CR000: Capture Register, CR010: Capture Register) (2/3)

(b) TOC00 = 13H, PRM00 = C0H, CRC00 = 05H, TMC00 = 0AH

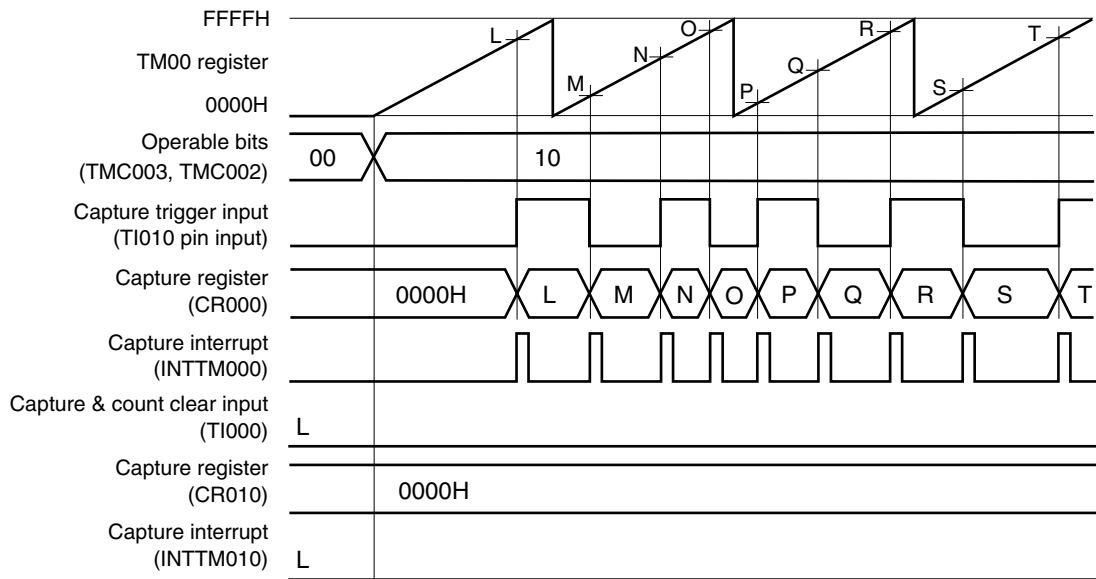

This is a timing example where an edge is not input to the TI000 pin, in an application where the count value is captured to CR000 when the rising or falling edge of the TI010 pin is detected.

Figure 6-29. Timing Example of Clear & Start Mode Entered by TI000 Pin Valid Edge Input (CR000: Capture Register, CR010: Capture Register) (3/3)

(c) TOC00 = 13H, PRM00 = 00H, CRC00 = 07H, TMC00 = 0AH

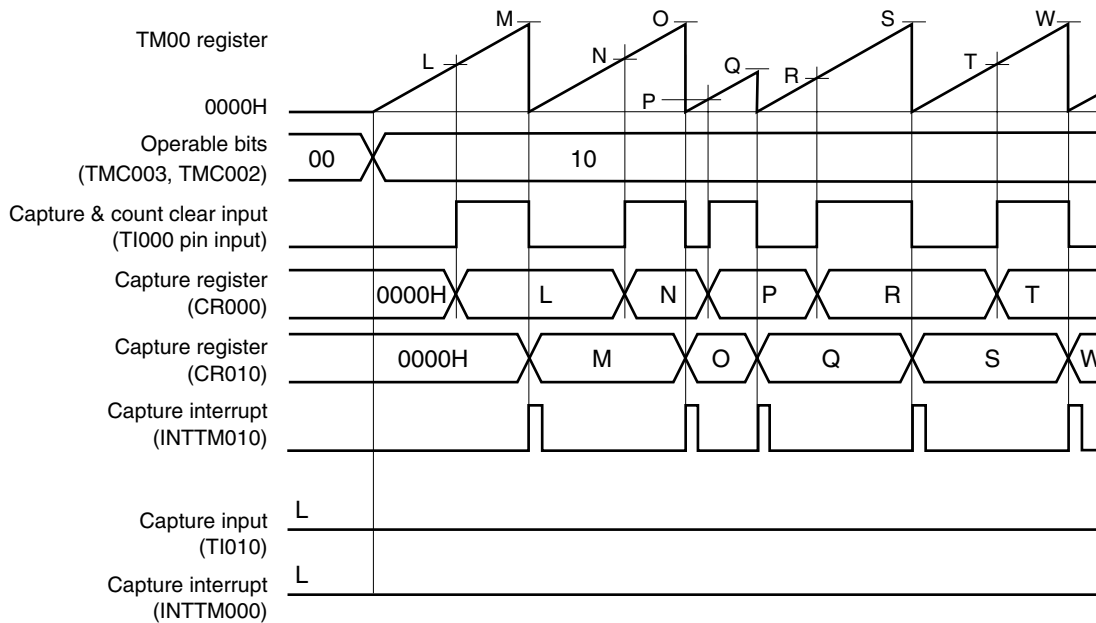

This is an application example where the pulse width of the signal input to the TI000 pin is measured.

By setting CRC00, the count value can be captured to CR000 in the phase reverse to the falling edge of the TI000 pin (i.e., rising edge) and to CR010 at the falling edge of the TI000 pin.

The high- and low-level widths of the input pulse can be calculated by the following expressions.

- High-level width = [CR010 value] – [CR000 value] × [Count clock cycle]
- Low-level width = [CR000 value] × [Count clock cycle]

If the reverse phase of the TI000 pin is selected as a trigger to capture the count value to CR000, the INTTM000 signal is not generated. Read the values of CR000 and CR010 to measure the pulse width immediately after the INTTM010 signal is generated.

However, if the valid edge specified by bits 6 and 5 (ES101 and ES100) of prescaler mode register 00 (PRM00) is input to the TI010 pin, the count value is not captured but the INTTM000 signal is generated. To measure the pulse width of the TI000 pin, mask the INTTM000 signal when it is not used.

Figure 6-30. Example of Register Settings in Clear & Start Mode Entered by TI000 Pin Valid Edge Input (1/2)

(a) 16-bit timer mode control register 00 (TMC00)

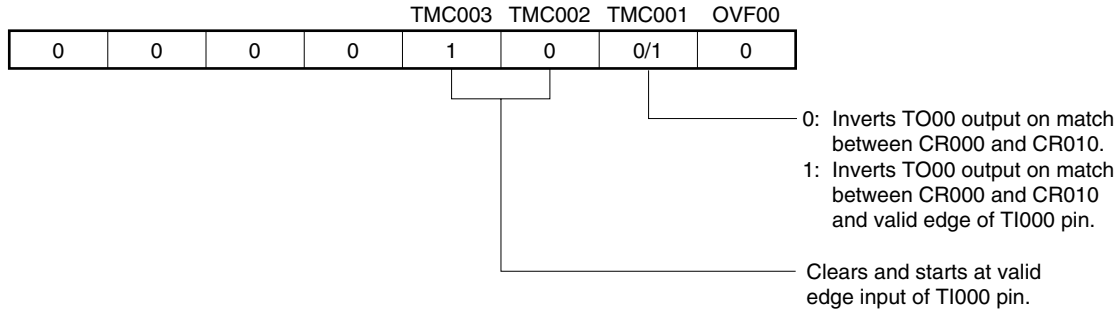

(b) Capture/compare control register 00 (CRC00)

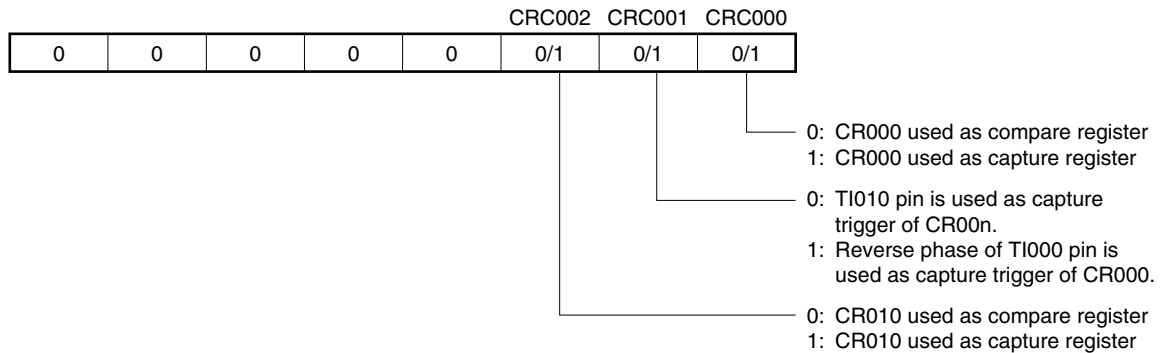

(c) 16-bit timer output control register 00 (TOC00)

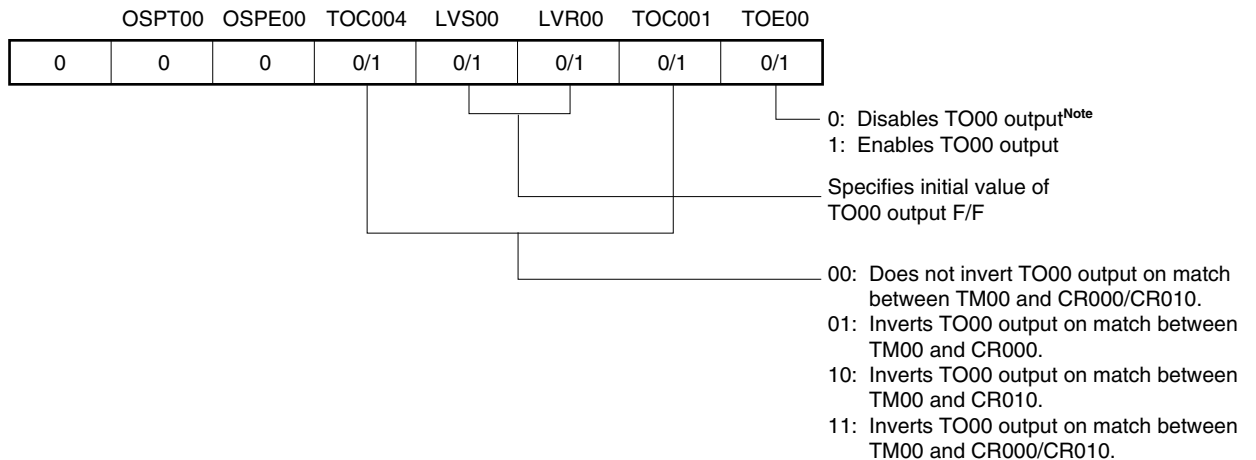

Note The timer output (TO00) cannot be used when detecting the valid edge of the TI010 pin is used.

Figure 6-30. Example of Register Settings in Clear & Start Mode Entered by TI000 Pin Valid Edge Input (2/2)

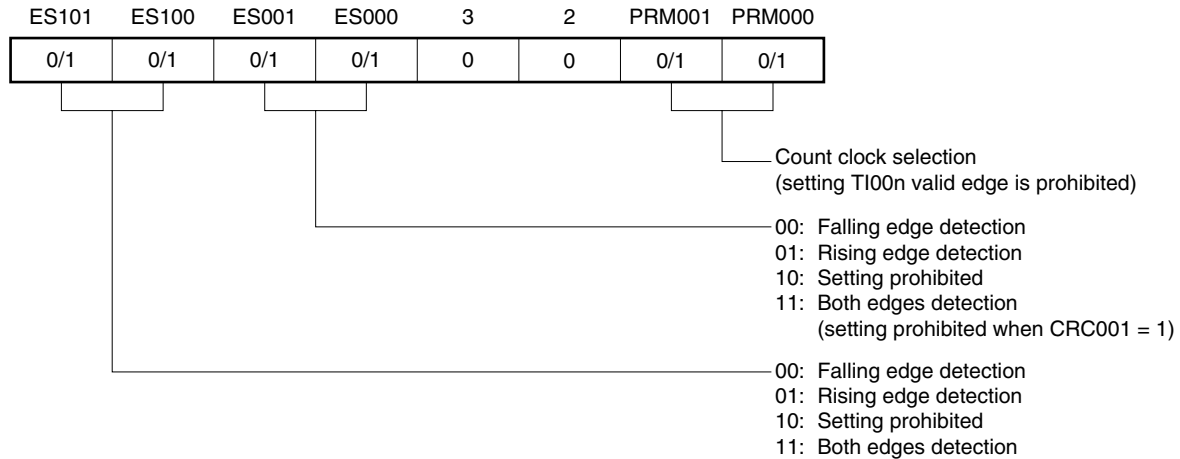
(d) Prescaler mode register 00 (PRM00)**(e) 16-bit timer counter 00 (TM00)**

By reading TM00, the count value can be read.

(f) 16-bit capture/compare register 000 (CR000)

When this register is used as a compare register and when its value matches the count value of TM00, an interrupt signal (INTTM000) is generated. The count value of TM00 is not cleared.

To use this register as a capture register, select either the TI000 or TI010 pin^{Note} input as a capture trigger. When the valid edge of the capture trigger is detected, the count value of TM00 is stored in CR000.

Note The timer output (TO00) cannot be used when detection of the valid edge of the TI010 pin is used.

(g) 16-bit capture/compare register 010 (CR010)

When this register is used as a compare register and when its value matches the count value of TM00, an interrupt signal (INTTM010) is generated. The count value of TM00 is not cleared.

When this register is used as a capture register, the TI000 pin input is used as a capture trigger. When the valid edge of the capture trigger is detected, the count value of TM00 is stored in CR010.

Figure 6-31. Example of Software Processing in Clear & Start Mode Entered by TI000 Pin Valid Edge Input

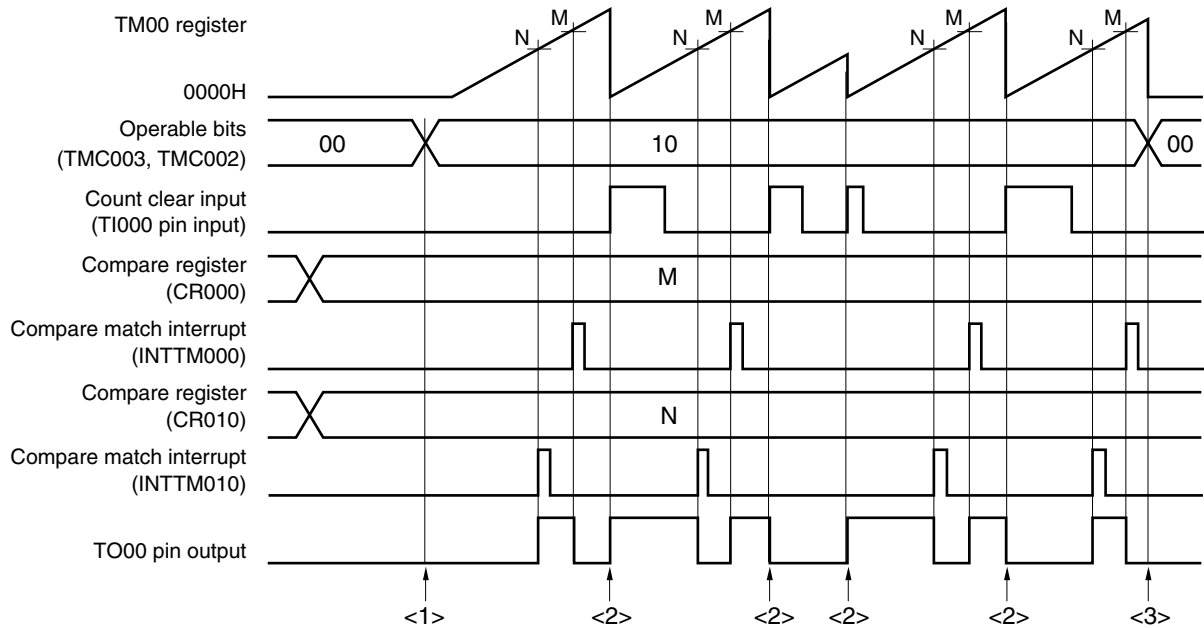

<1> Count operation start flow

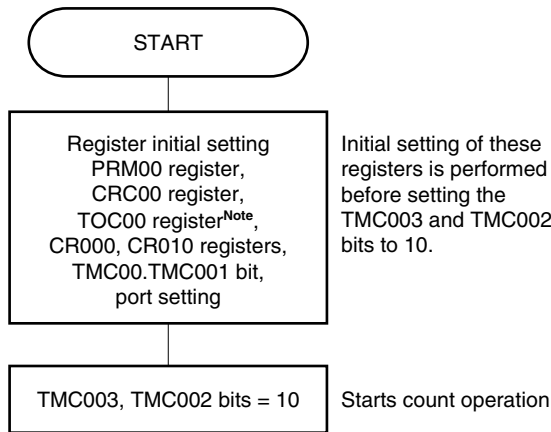

<3> Count operation stop flow

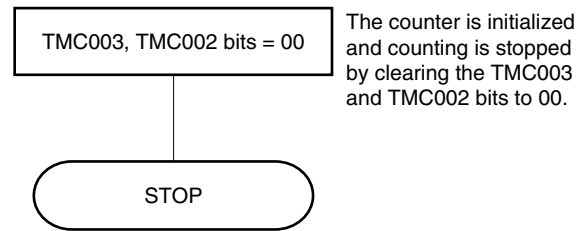

<2> TM00 register clear & start flow

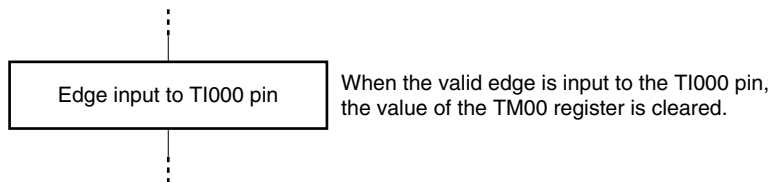

Note Care must be exercised when setting TOC00. For details, see 6.3 (3) 16-bit timer output control register 00 (TOC00).

6.4.5 Free-running timer operation

When bits 3 and 2 (TMC003 and TMC002) of 16-bit timer mode control register 00 (TMC00) are set to 01 (free-running timer mode), 16-bit timer/event counter 00 continues counting up in synchronization with the count clock. When it has counted up to FFFFH, the overflow flag (OVF00) is set to 1 at the next clock, and TM00 is cleared (to 0000H) and continues counting. Clear OVF00 to 0 by executing the CLR instruction via software.

The following three types of free-running timer operations are available.

- Both CR000 and CR010 are used as compare registers.
- One of CR000 or CR010 is used as a compare register and the other is used as a capture register.
- Both CR000 and CR010 are used as capture registers.

Remarks 1. For the setting of the I/O pins, see **6.3 (5) Port mode register 0 (PM0)**.

2. For how to enable the INTTM000 signal interrupt, see **CHAPTER 15 INTERRUPT FUNCTIONS**.

(1) Free-running timer mode operation

(CR000: compare register, CR010: compare register)

**Figure 6-32. Block Diagram of Free-Running Timer Mode
(CR000: Compare Register, CR010: Compare Register)**

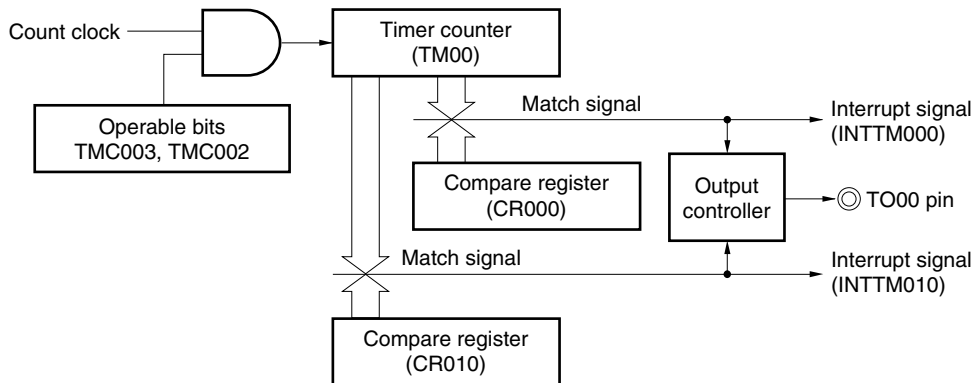

**Figure 6-33. Timing Example of Free-Running Timer Mode
(CR000: Compare Register, CR010: Compare Register)**

• TOC00 = 13H, PRM00 = 00H, CRC00 = 00H, TMC00 = 04H

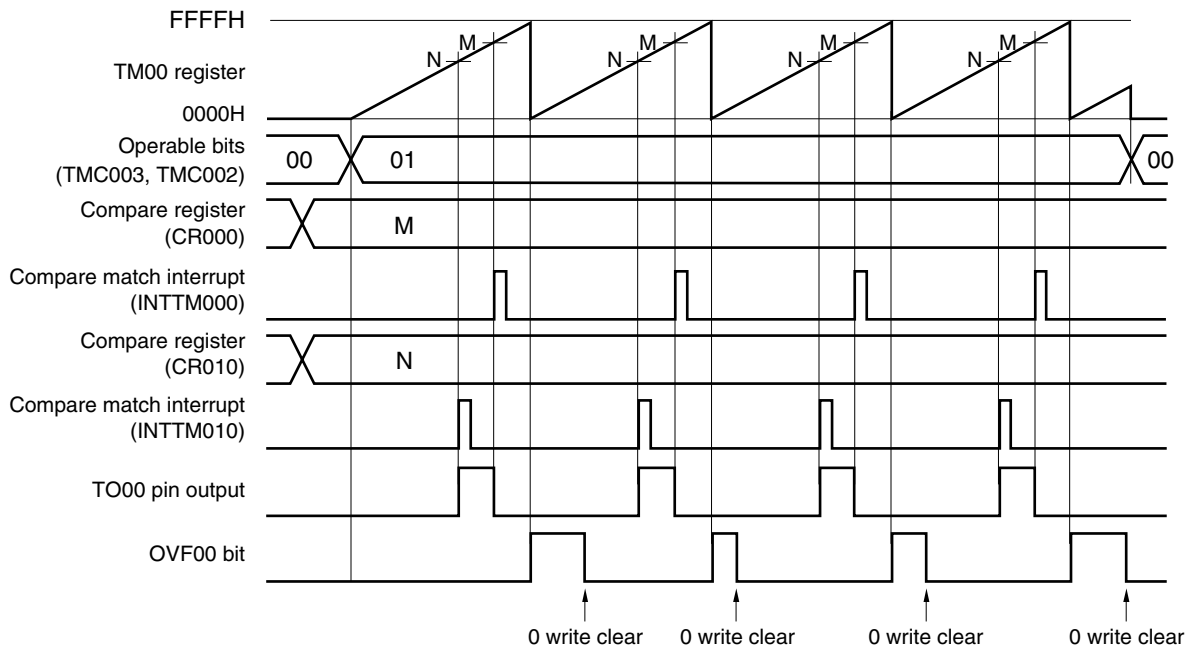

This is an application example where two compare registers are used in the free-running timer mode. The output level of the TO00 pin is reversed each time the count value of TM00 matches the set value of CR000 or CR010. When the count value matches the register value, the INTTM000 or INTTM010 signal is generated.

**(2) Free-running timer mode operation
(CR000: compare register, CR010: capture register)**

**Figure 6-34. Block Diagram of Free-Running Timer Mode
(CR000: Compare Register, CR010: Capture Register)**

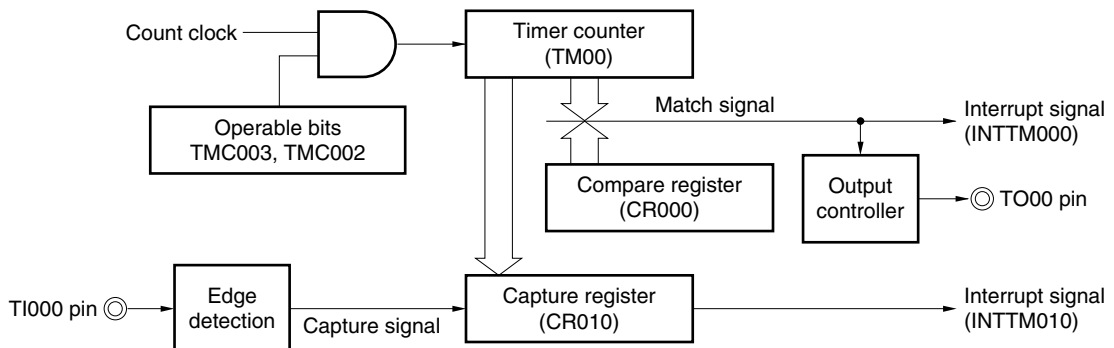

<R>

**Figure 6-35. Timing Example of Free-Running Timer Mode
(CR000: Compare Register, CR010: Capture Register)**

• TOC00 = 13H, PRM00 = 10H, CRC00 = 04H, TMC00 = 04H

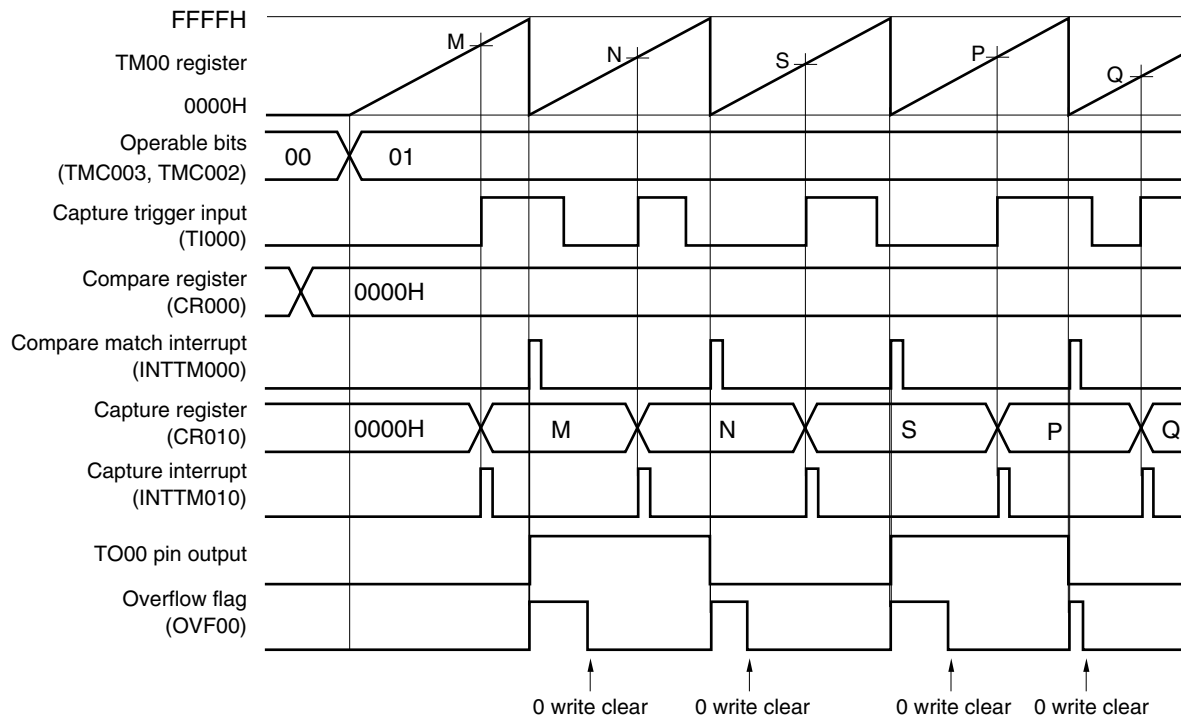

This is an application example where a compare register and a capture register are used at the same time in the free-running timer mode.

In this example, the INTTM000 signal is generated and the output level of the TO00 pin is reversed each time the count value of TM00 matches the set value of CR000 (compare register). In addition, the INTTM010 signal is generated and the count value of TM00 is captured to CR010 each time the valid edge of the TI000 pin is detected.

(3) Free-running timer mode operation
 (CR000: capture register, CR010: capture register)

Figure 6-36. Block Diagram of Free-Running Timer Mode
 (CR000: Capture Register, CR010: Capture Register)

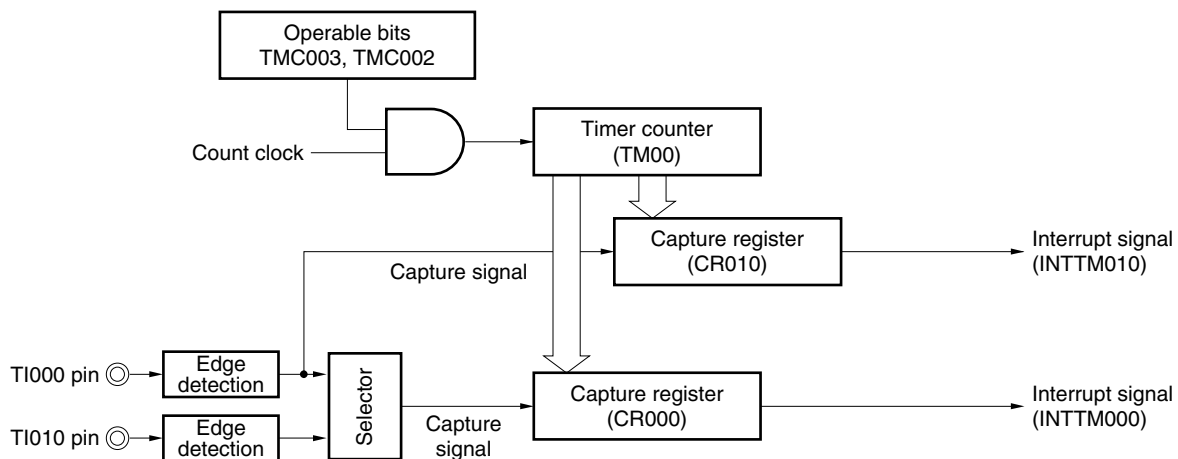

Remark If both CR000 and CR010 are used as capture registers in the free-running timer mode, the output level of the TO00 pin is not inverted. However, it can be inverted each time the valid edge of the TI000 pin is detected if bit 1 (TMC001) of 16-bit timer mode control register 00 (TMC00) is set to 1.

**Figure 6-37. Timing Example of Free-Running Timer Mode
(CR000: Capture Register, CR010: Capture Register) (1/2)**

(a) TOC00 = 13H, PRM00 = 50H, CRC00 = 05H, TMC00 = 04H

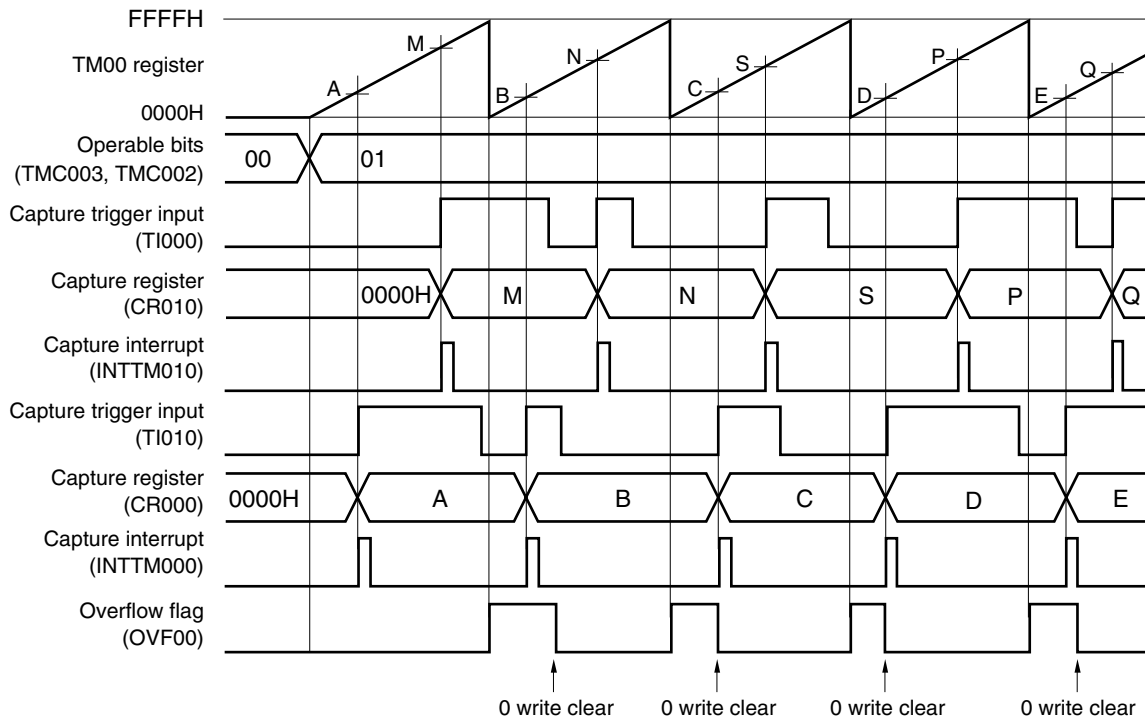

This is an application example where the count values that have been captured at the valid edges of separate capture trigger signals are stored in separate capture registers in the free-running timer mode.

The count value is captured to CR010 when the valid edge of the TI000 pin input is detected and to CR000 when the valid edge of the TI010 pin input is detected.

**Figure 6-37. Timing Example of Free-Running Timer Mode
(CR000: Capture Register, CR010: Capture Register) (2/2)**

(b) TOC00 = 13H, PRM00 = C0H, CRC00 = 05H, TMC00 = 04H

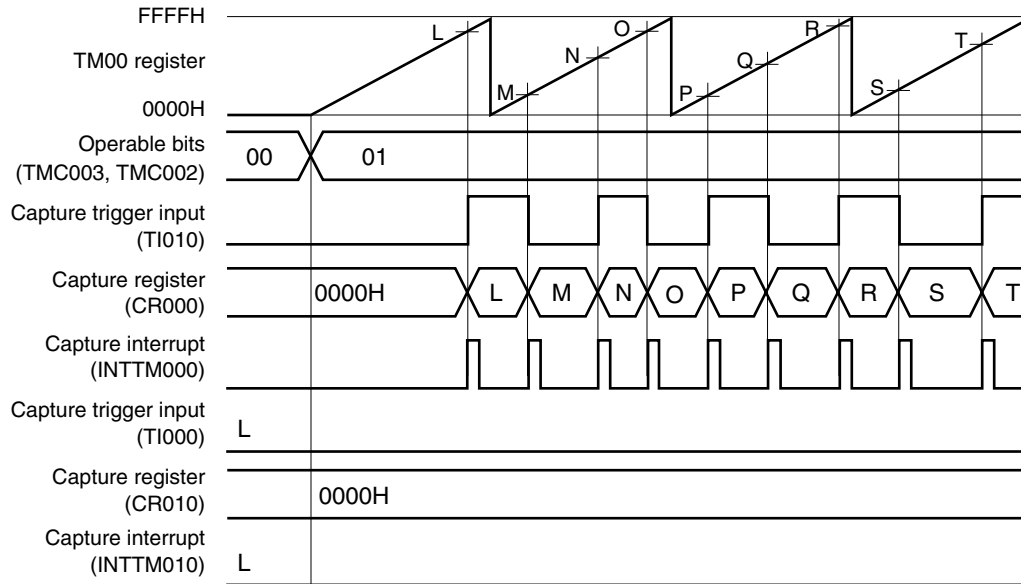

This is an application example where both the edges of the TI010 pin are detected and the count value is captured to CR000 in the free-running timer mode.

When both CR000 and CR010 are used as capture registers and when the valid edge of only the TI010 pin is to be detected, the count value cannot be captured to CR010.

Figure 6-38. Example of Register Settings in Free-Running Timer Mode (1/2)

(a) 16-bit timer mode control register 00 (TMC00)

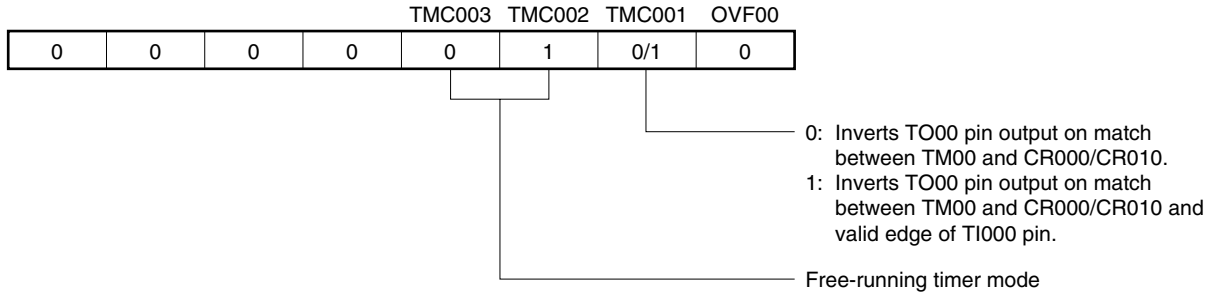

(b) Capture/compare control register 00 (CRC00)

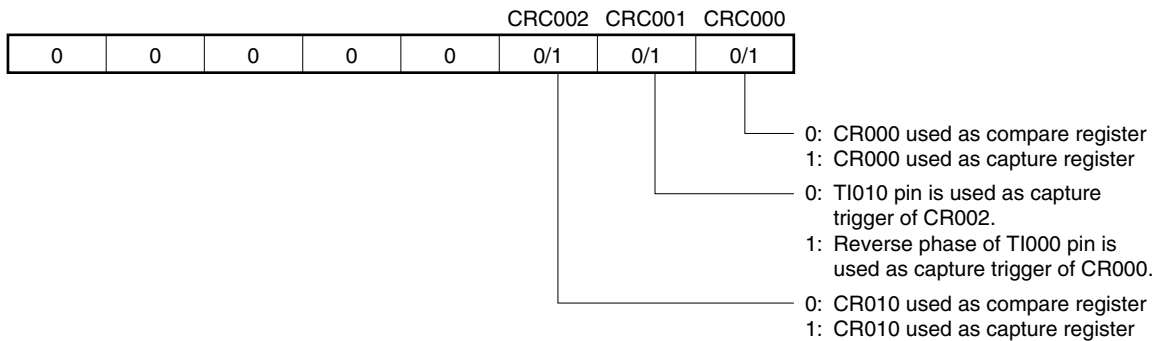

(c) 16-bit timer output control register 00 (TOC00)

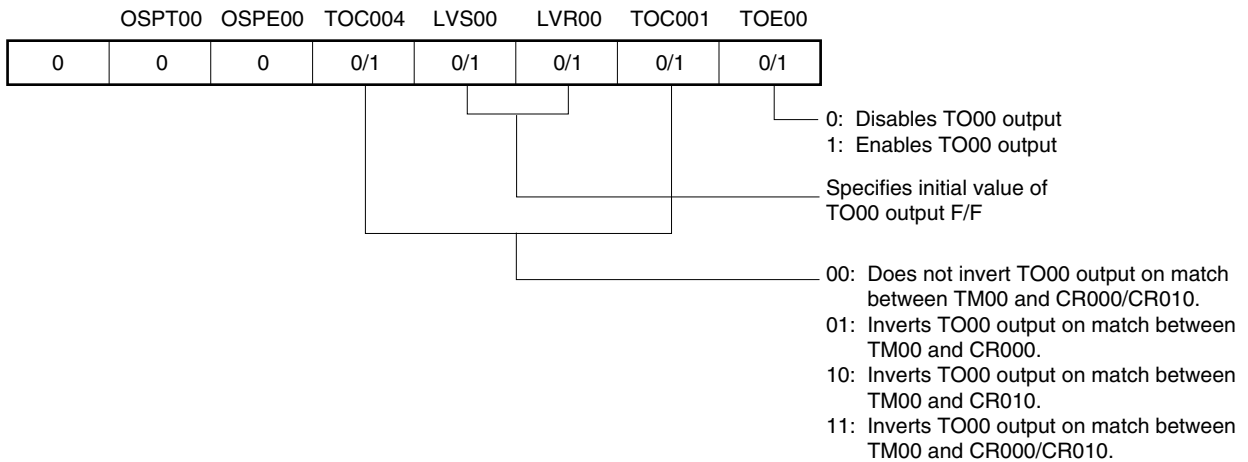
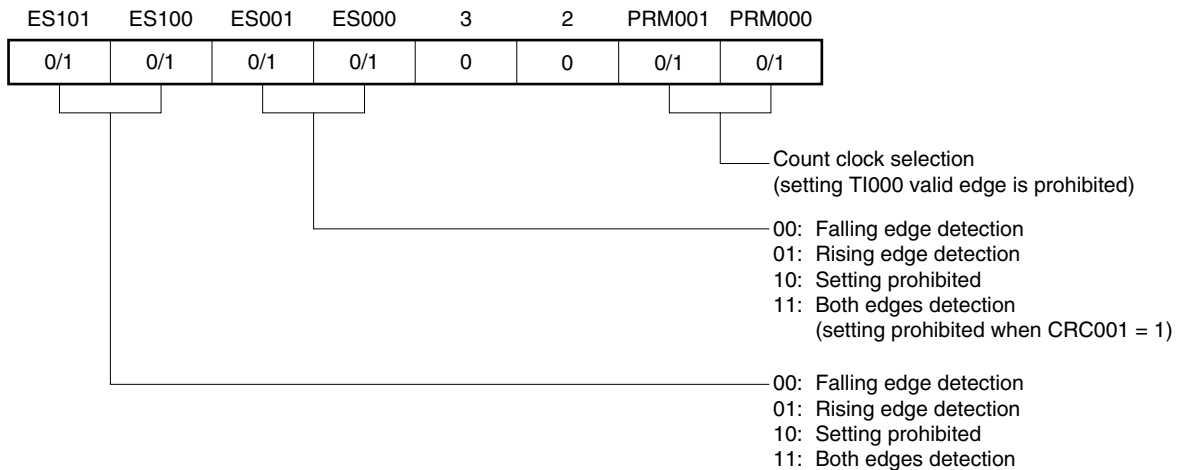

Figure 6-38. Example of Register Settings in Free-Running Timer Mode (2/2)

(d) Prescaler mode register 00 (PRM00)**(e) 16-bit timer counter 00 (TM00)**

By reading TM00, the count value can be read.

(f) 16-bit capture/compare register 000 (CR000)

When this register is used as a compare register and when its value matches the count value of TM00, an interrupt signal (INTTM000) is generated. The count value of TM00 is not cleared.

To use this register as a capture register, select either the TI000 or TI010 pin input as a capture trigger. When the valid edge of the capture trigger is detected, the count value of TM00 is stored in CR000.

(g) 16-bit capture/compare register 010 (CR010)

When this register is used as a compare register and when its value matches the count value of TM00, an interrupt signal (INTTM010) is generated. The count value of TM00 is not cleared.

When this register is used as a capture register, the TI000 pin input is used as a capture trigger. When the valid edge of the capture trigger is detected, the count value of TM00 is stored in CR010.

Figure 6-39. Example of Software Processing in Free-Running Timer Mode

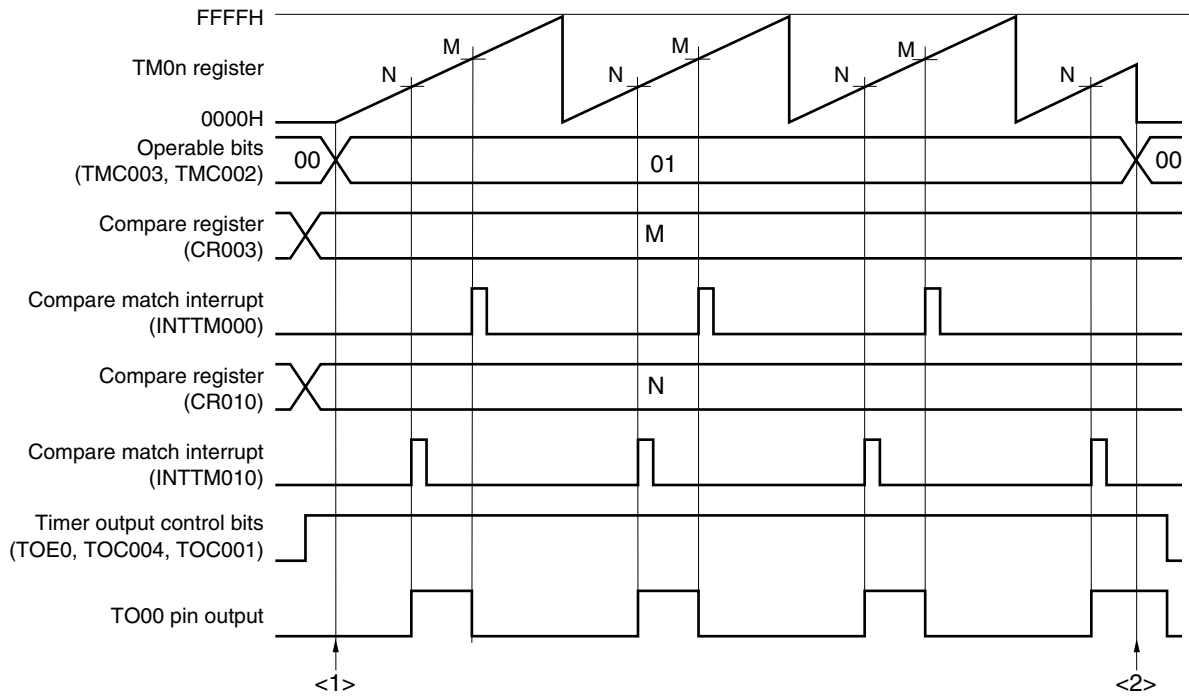

<1> Count operation start flow

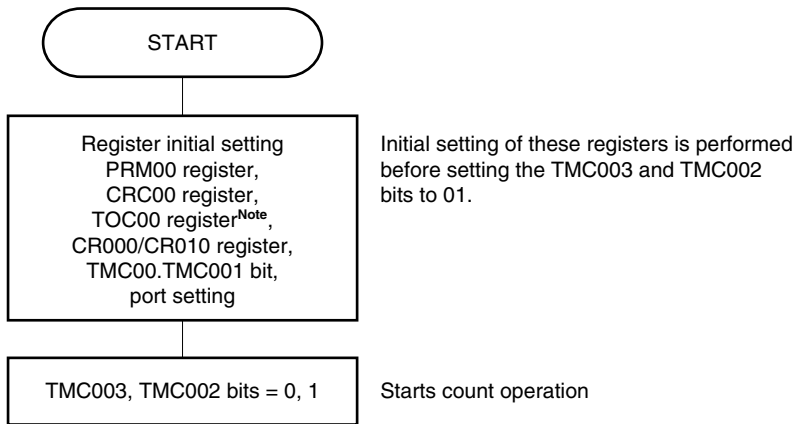

<2> Count operation stop flow

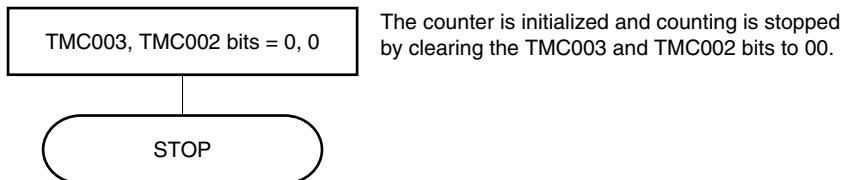

Note Care must be exercised when setting TOC00. For details, see 6.3 (3) 16-bit timer output control register 00 (TOC00).

6.4.6 PPG output operation

A square wave having a pulse width set in advance by CR010 is output from the TO00 pin as a PPG (Programmable Pulse Generator) signal during a cycle set by CR000 when bits 3 and 2 (TMC003 and TMC002) of 16-bit timer mode control register 00 (TMC00) are set to 11 (clear & start upon a match between TM00 and CR000).

The pulse cycle and duty factor of the pulse generated as the PPG output are as follows.

- Pulse cycle = (Set value of CR000 + 1) × Count clock cycle
- Duty = (Set value of CR010 + 1) / (Set value of CR000 + 1)

Caution To change the duty factor (value of CR010) during operation, see 6.5.1 Rewriting CR010 during TM00 operation.

- Remarks**
1. For the setting of I/O pins, see 6.3 (5) Port mode register 0 (PM0).
 2. For how to enable the INTTM000 signal interrupt, see CHAPTER 15 INTERRUPT FUNCTIONS.

Figure 6-40. Block Diagram of PPG Output Operation

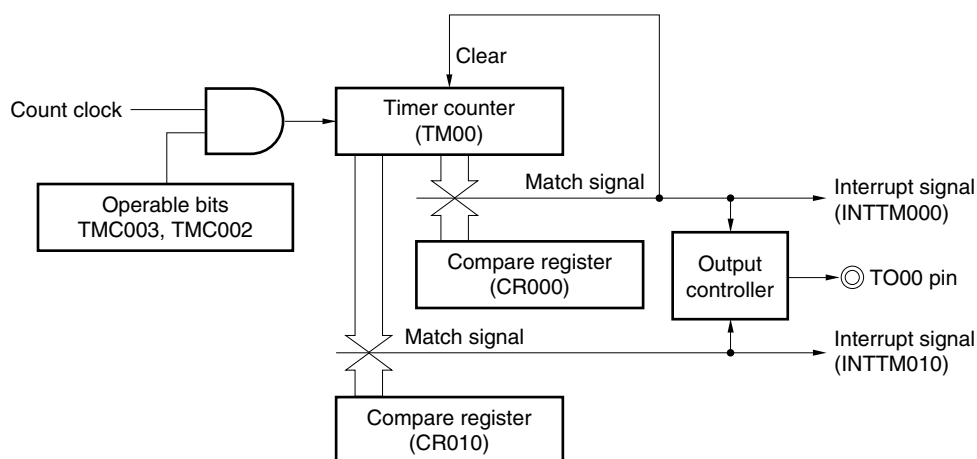
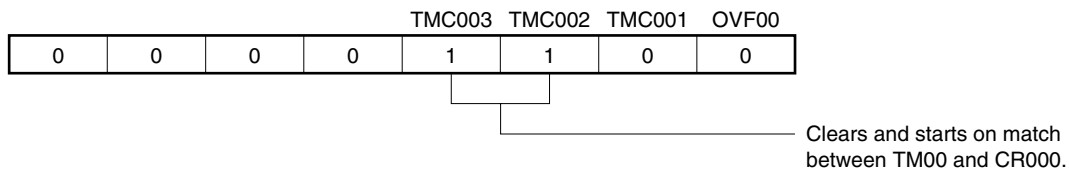
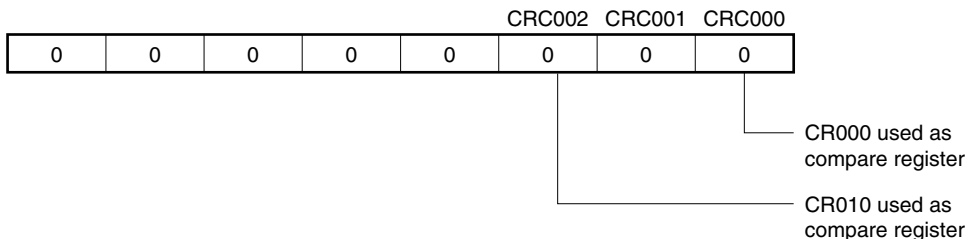

Figure 6-41. Example of Register Settings for PPG Output Operation

(a) 16-bit timer mode control register 00 (TMC00)



(b) Capture/compare control register 00 (CRC00)



(c) 16-bit timer output control register 00 (TOC00)

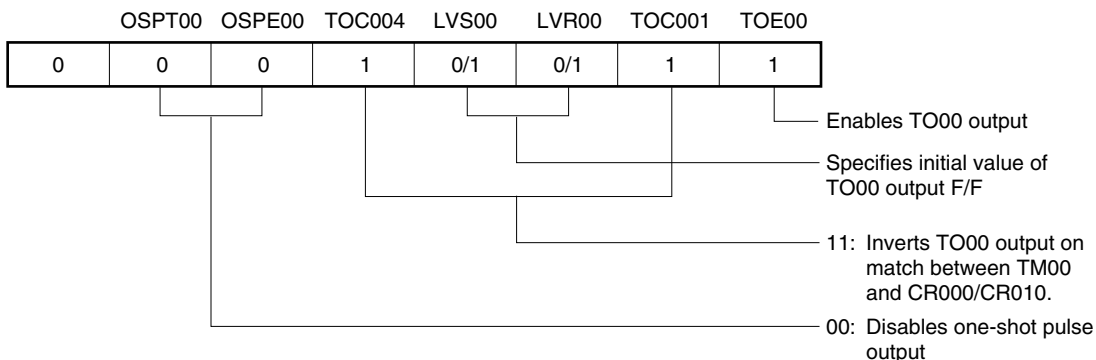

(d) Prescaler mode register 00 (PRM00)

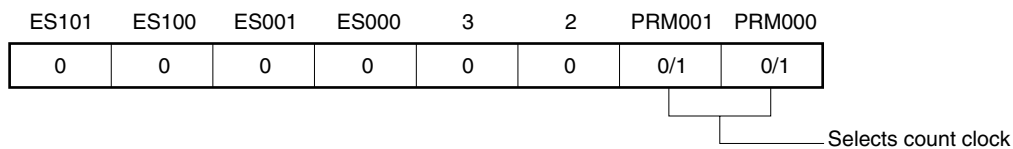

(e) 16-bit timer counter 00 (TM00)

By reading TM00, the count value can be read.

(f) 16-bit capture/compare register 000 (CR000)

An interrupt signal (INTTM000) is generated when the value of this register matches the count value of TM00. The count value of TM00 is not cleared.

(g) 16-bit capture/compare register 010 (CR010)

An interrupt signal (INTTM010) is generated when the value of this register matches the count value of TM00. The count value of TM00 is not cleared.

<R> **Caution** Set values to CR000 and CR010 such that the condition $0000H \leq CR010 < CR000 \leq FFFFH$ is satisfied.

Figure 6-42. Example of Software Processing for PPG Output Operation

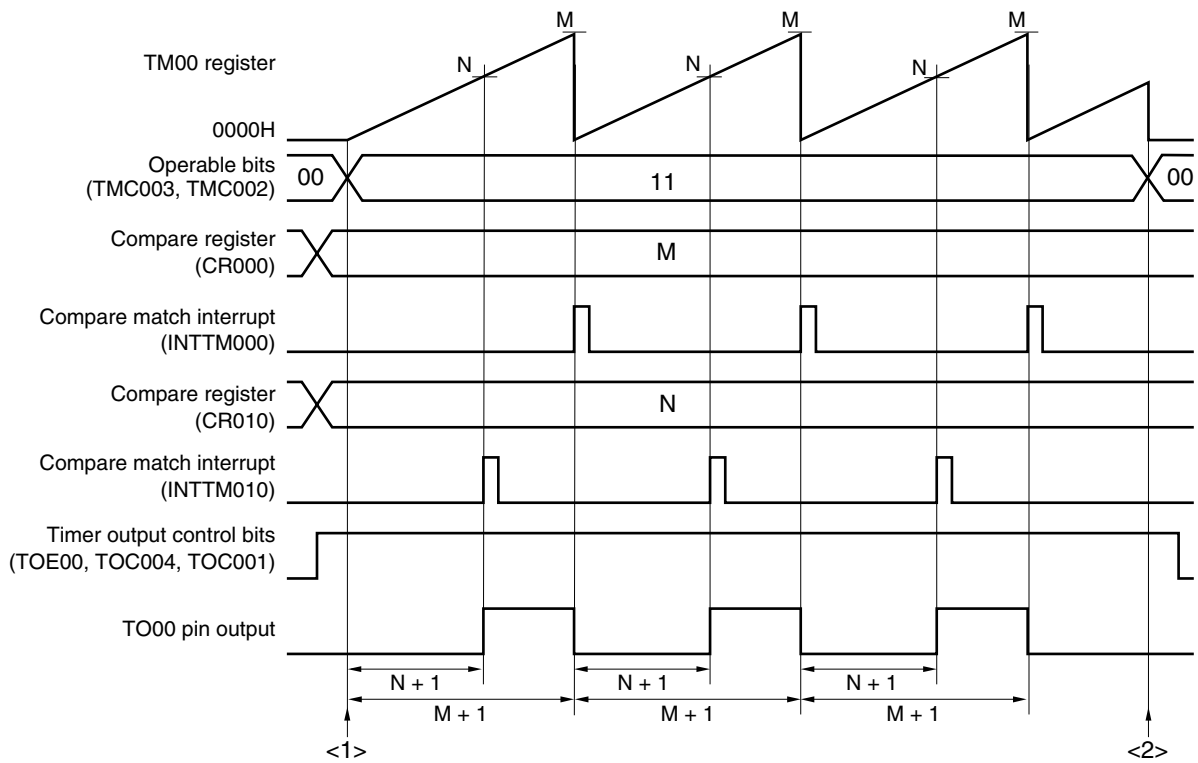

<1> Count operation start flow

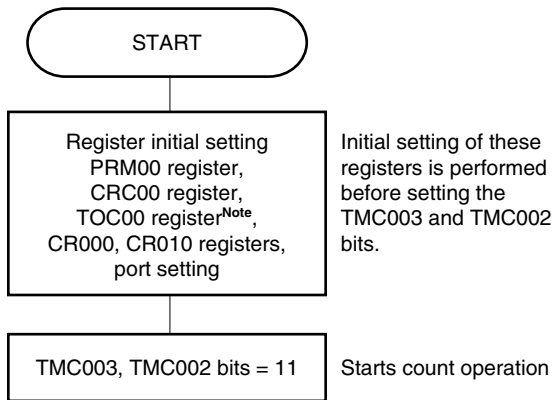

<2> Count operation stop flow

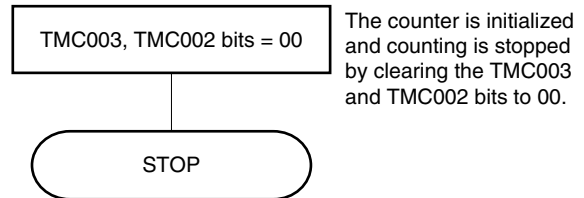

Note Care must be exercised when setting TOC00. For details, see 6.3 (3) 16-bit timer output control register 00 (TOC00).

Remark PPG pulse cycle = $(M + 1) \times \text{Count clock cycle}$
 PPG duty = $(N + 1)/(M + 1)$

6.4.7 One-shot pulse output operation

A one-shot pulse can be output by setting bits 3 and 2 (TMC003 and TMC002) of the 16-bit timer mode control register 00 (TMC00) to 01 (free-running timer mode) or to 10 (clear & start mode entered by the TI000 pin valid edge) and setting bit 5 (OSPE00) of 16-bit timer output control register 00 (TOC00) to 1.

When bit 6 (OSPT00) of TOC00 is set to 1 or when the valid edge is input to the TI000 pin during timer operation, clearing & starting of TM00 is triggered, and a pulse of the difference between the values of CR000 and CR010 is output only once from the TO00 pin.

- Cautions**
1. Do not input the trigger again (setting OSPT00 to 1 or detecting the valid edge of the TI000 pin) while the one-shot pulse is output. To output the one-shot pulse again, generate the trigger after the current one-shot pulse output has completed.
 2. To use only the setting of OSPT00 to 1 as the trigger of one-shot pulse output, do not change the level of the TI000 pin or its alternate function port pin. Otherwise, the pulse will be unexpectedly output.

- Remarks**
1. For the setting of the I/O pins, see 6.3 (5) Port mode register 0 (PM0).
 2. For how to enable the INTTM000 signal interrupt, see CHAPTER 15 INTERRUPT FUNCTIONS.

Figure 6-43. Block Diagram of One-Shot Pulse Output Operation

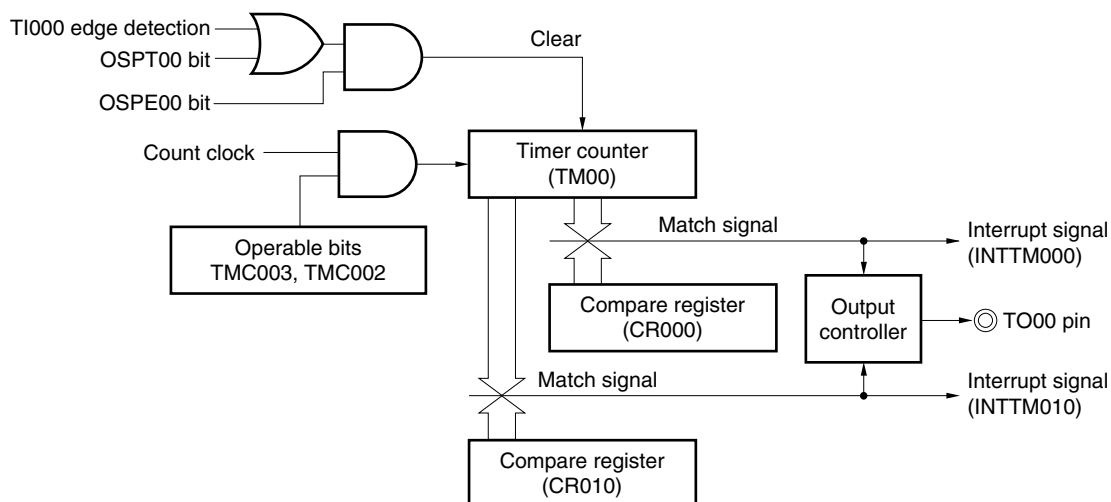
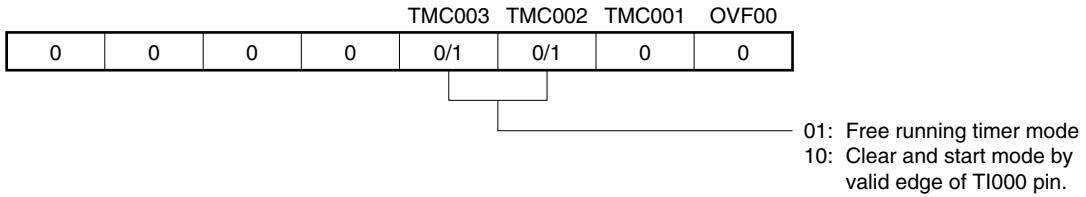
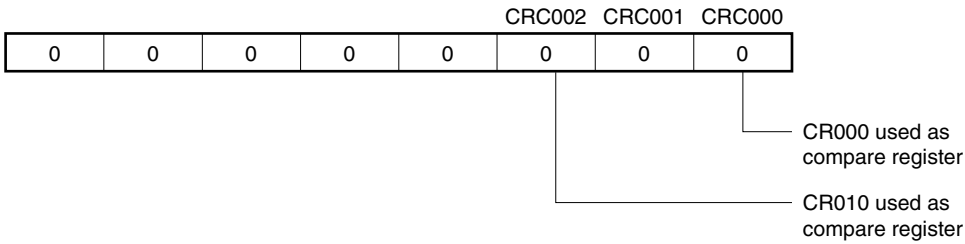

Figure 6-44. Example of Register Settings for One-Shot Pulse Output Operation (1/2)

(a) 16-bit timer mode control register 00 (TMC00)



(b) Capture/compare control register 00 (CRC00)



(c) 16-bit timer output control register 00 (TOC00)

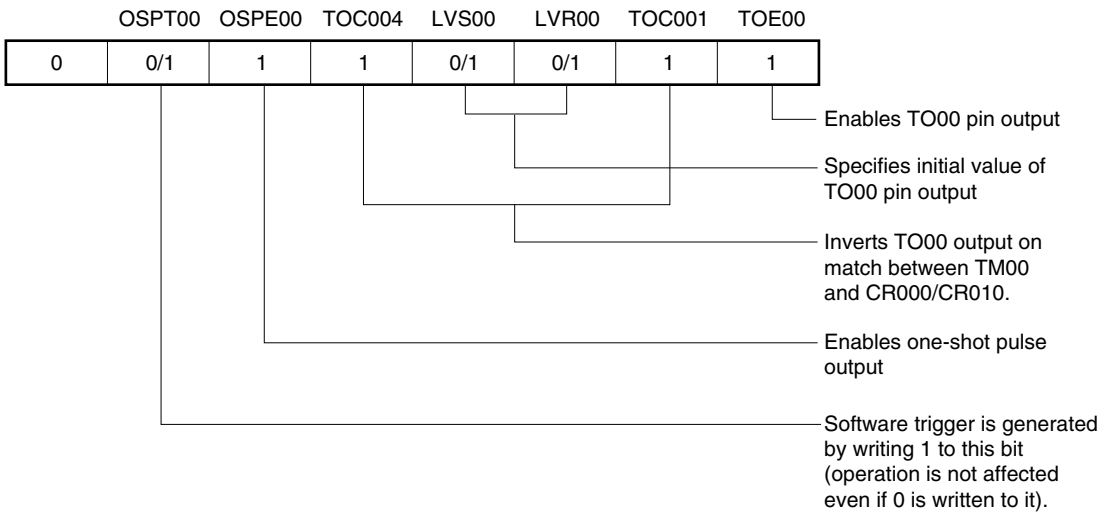

(d) Prescaler mode register 00 (PRM00)

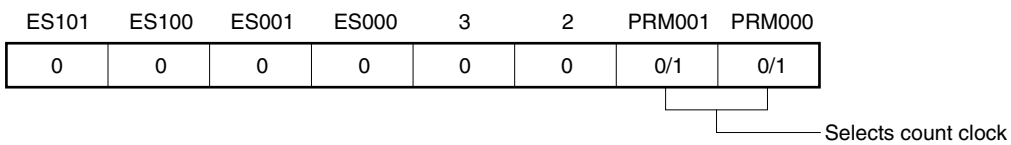

Figure 6-44. Example of Register Settings for One-Shot Pulse Output Operation (2/2)**(e) 16-bit timer counter 00 (TM00)**

By reading TM00, the count value can be read.

(f) 16-bit capture/compare register 000 (CR000)

This register is used as a compare register when a one-shot pulse is output. When the value of TM00 matches that of CR000, an interrupt signal (INTTM000) is generated and the output level of the TO00 pin is inverted.

(g) 16-bit capture/compare register 010 (CR010)

This register is used as a compare register when a one-shot pulse is output. When the value of TM00 matches that of CR010, an interrupt signal (INTTM010) is generated and the output level of the TO00 pin is inverted.

<R> **Caution** Do not set the same value to CR000 and CR010.

Figure 6-45. Example of Software Processing for One-Shot Pulse Output Operation (1/2)

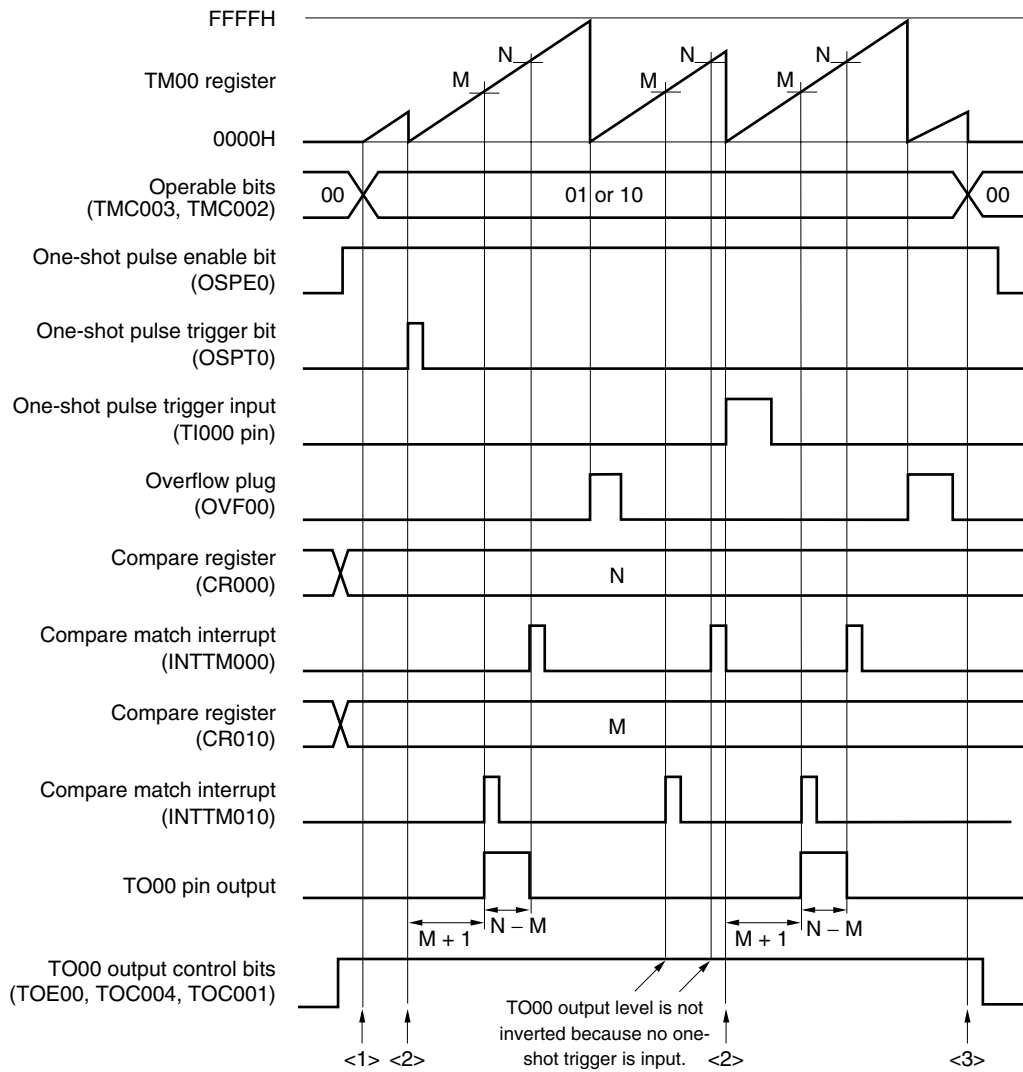

- Time from when the one-shot pulse trigger is input until the one-shot pulse is output
= $(M + 1) \times \text{Count clock cycle}$
- One-shot pulse output active level width
= $(N - M) \times \text{Count clock cycle}$

Figure 6-45. Example of Software Processing for One-Shot Pulse Output Operation (2/2)

<1> Count operation start flow

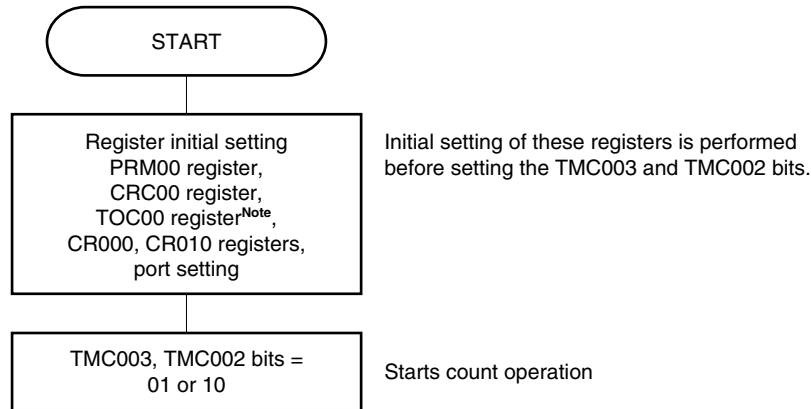

<2> One-shot trigger input flow

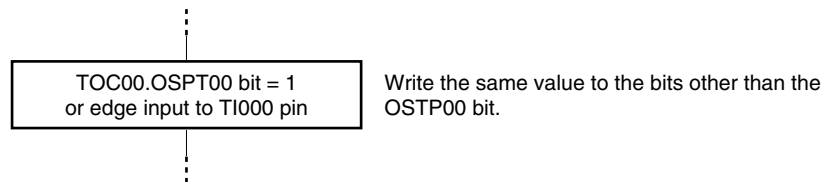

<3> Count operation stop flow

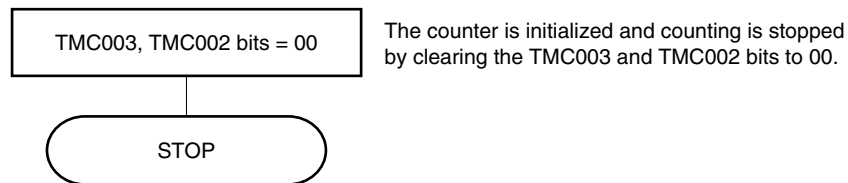

Note Care must be exercised when setting TOC00. For details, see 6.3 (3) 16-bit timer output control register 00 (TOC00).

6.4.8 Pulse width measurement operation

TM00 can be used to measure the pulse width of the signal input to the TI000 and TI010 pins.

Measurement can be accomplished by operating the 16-bit timer/event counter 00 in the free-running timer mode or by restarting the timer in synchronization with the signal input to the TI000 pin.

When an interrupt is generated, read the value of the valid capture register and measure the pulse width. Check bit 0 (OVF00) of 16-bit timer mode control register 00 (TMC00). If it is set (to 1), clear it to 0 by software.

Figure 6-46. Block Diagram of Pulse Width Measurement (Free-Running Timer Mode)

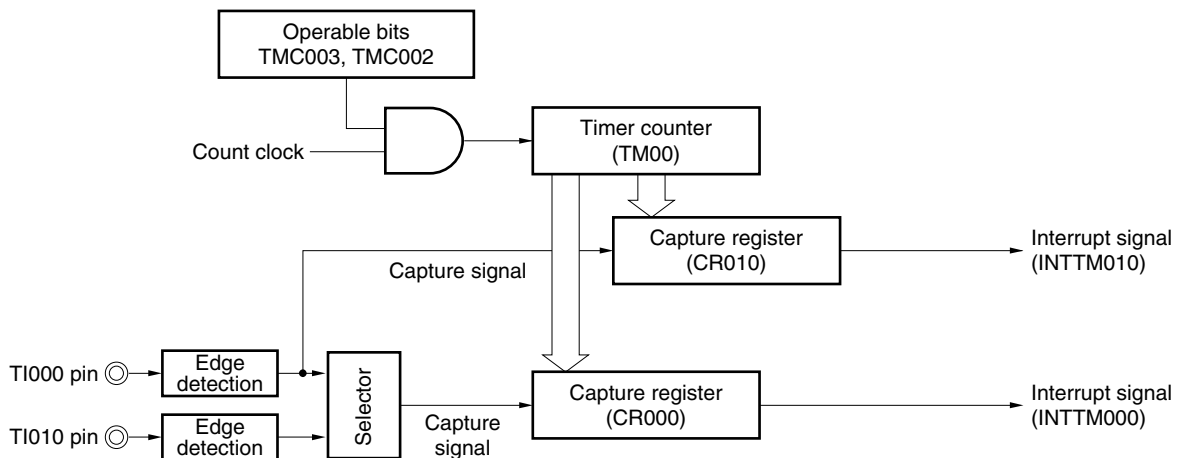
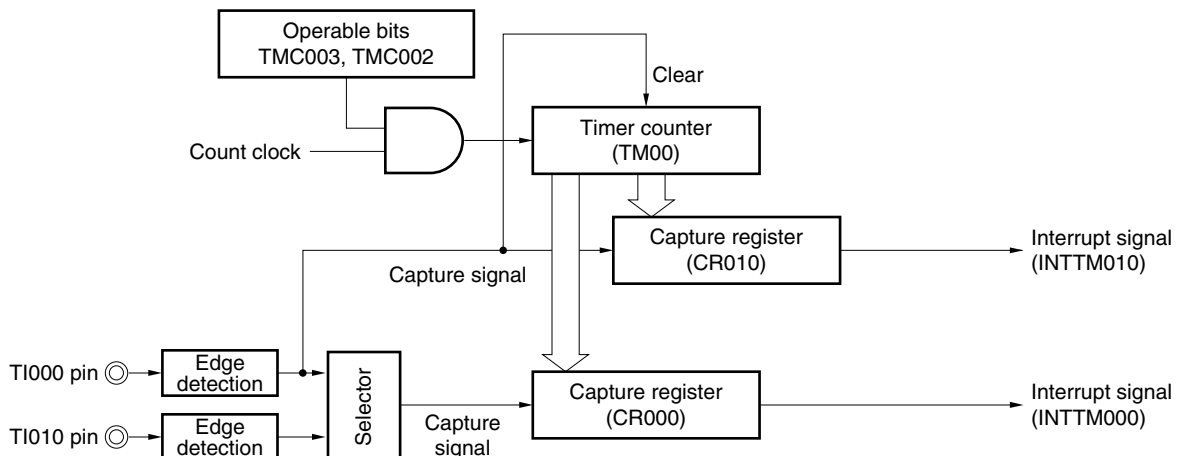

Figure 6-47. Block Diagram of Pulse Width Measurement (Clear & Start Mode Entered by TI000 Pin Valid Edge Input)



A pulse width can be measured in the following three ways.

- Measuring the pulse width by using two input signals of the TI000 and TI010 pins (free-running timer mode)
- Measuring the pulse width by using one input signal of the TI000 pin (free-running timer mode)
- Measuring the pulse width by using one input signal of the TI000 pin (clear & start mode entered by the TI000 pin valid edge input)

Remarks 1. For the setting of the I/O pins, see **6.3 (5) Port mode register 0 (PM0)**.

2. For how to enable the INTTM000 signal interrupt, see **CHAPTER 15 INTERRUPT FUNCTIONS**.

(1) Measuring the pulse width by using two input signals of the TI000 and TI010 pins (free-running timer mode)

Set the free-running timer mode (TMC003 and TMC002 = 01). When the valid edge of the TI000 pin is detected, the count value of TM00 is captured to CR010. When the valid edge of the TI010 pin is detected, the count value of TM00 is captured to CR000. Specify detection of both the edges of the TI000 and TI010 pins.

By this measurement method, the previous count value is subtracted from the count value captured by the edge of each input signal. Therefore, save the previously captured value to a separate register in advance.

If an overflow occurs, the value becomes negative if the previously captured value is simply subtracted from the current captured value and, therefore, a borrow occurs (bit 0 (CY) of the program status word (PSW) is set to 1). If this happens, ignore CY and take the calculated value as the pulse width. In addition, clear bit 0 (OVF00) of 16-bit timer mode control register 00 (TMC00) to 0.

Figure 6-48. Timing Example of Pulse Width Measurement (1)

• TMC00 = 04H, PRM00 = F0H, CRC00 = 05H

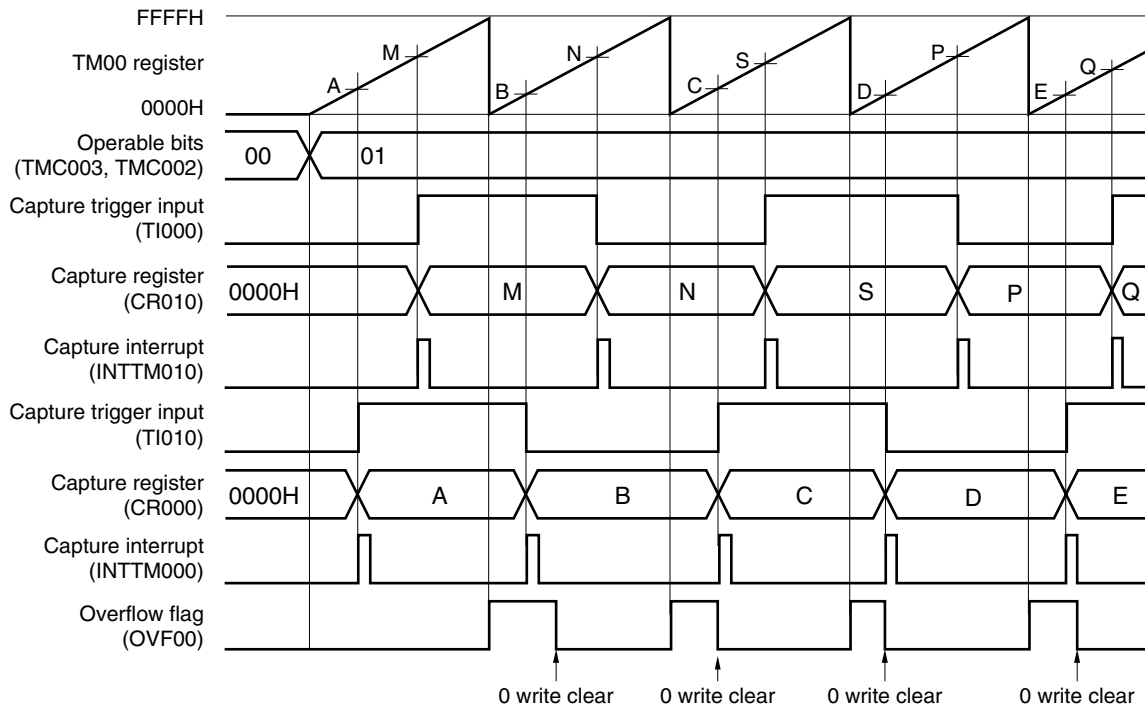

(2) Measuring the pulse width by using one input signal of the TI000 pin (free-running mode)

Set the free-running timer mode (TMC003 and TMC002 = 01). The count value of TM00 is captured to CR000 in the phase reverse to the valid edge detected on the TI000 pin. When the valid edge of the TI000 pin is detected, the count value of TM00 is captured to CR010.

By this measurement method, values are stored in separate capture registers when a width from one edge to another is measured. Therefore, the capture values do not have to be saved. By subtracting the value of one capture register from that of another, a high-level width, low-level width, and cycle are calculated.

If an overflow occurs, the value becomes negative if one captured value is simply subtracted from another and, therefore, a borrow occurs (bit 0 (CY) of the program status word (PSW) is set to 1). If this happens, ignore CY and take the calculated value as the pulse width. In addition, clear bit 0 (OVF00) of 16-bit timer mode control register 00 (TMC00) to 0.

Figure 6-49. Timing Example of Pulse Width Measurement (2)

• TMC00 = 04H, PRM00 = 10H, CRC00 = 07H

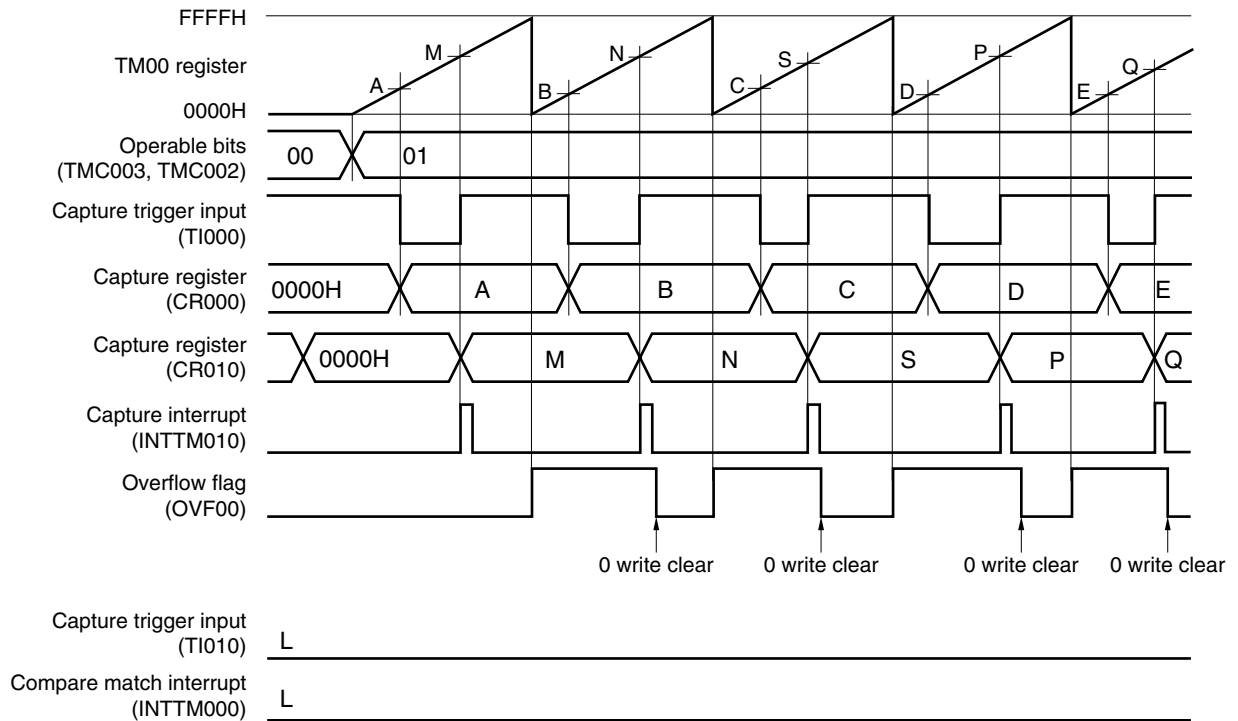

(3) Measuring the pulse width by using one input signal of the TI000 pin (clear & start mode entered by the TI000 pin valid edge input)

Set the clear & start mode entered by the TI000 pin valid edge (TMC003 and TMC002 = 10). The count value of TM00 is captured to CR000 in the phase reverse to the valid edge of the TI000 pin, and the count value of TM00 is captured to CR010 and TM00 is cleared (0000H) when the valid edge of the TI000 pin is detected. Therefore, a cycle is stored in CR010 if TM00 does not overflow.

If an overflow occurs, take the value that results from adding 10000H to the value stored in CR010 as a cycle. Clear bit 0 (OVF00) of 16-bit timer mode control register 00 (TMC00) to 0.

Figure 6-50. Timing Example of Pulse Width Measurement (3)

• TMC00 = 08H, PRM00 = 10H, CRC00 = 07H

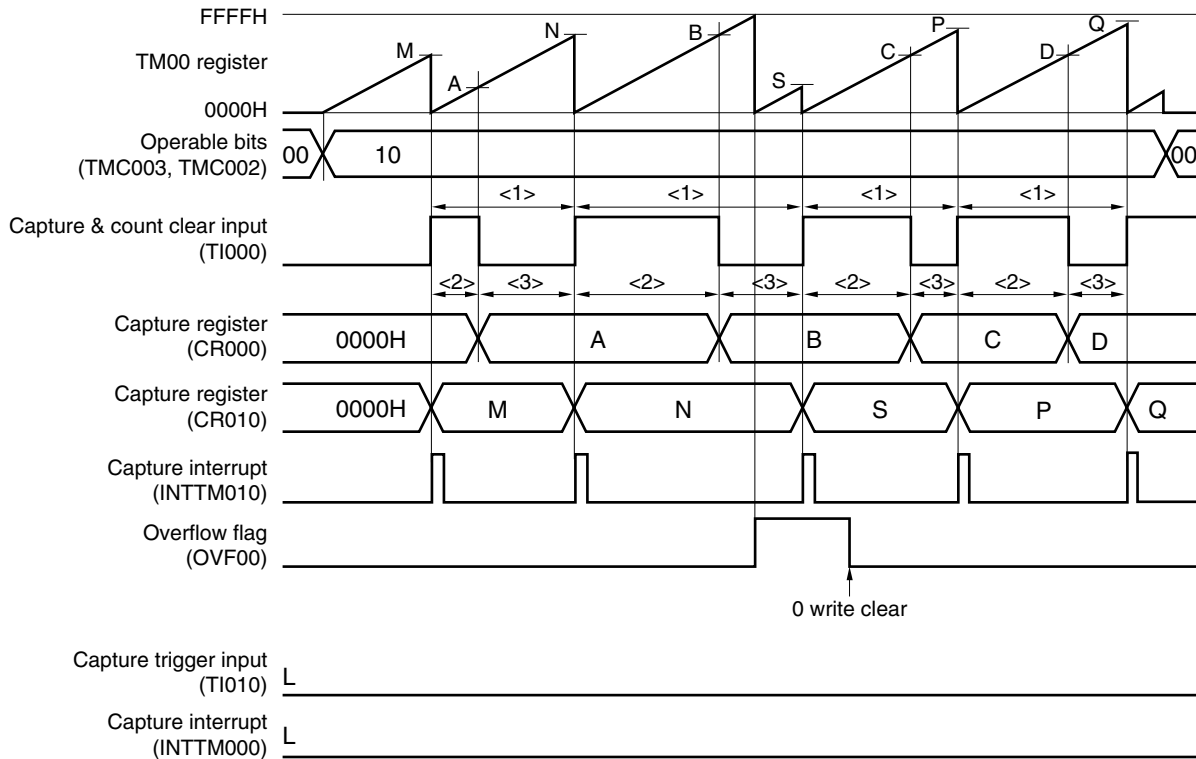

- <1> Pulse cycle = $(10000H \times \text{Number of times OVF00 bit is set to 1} + \text{Captured value of CR010}) \times \text{Count clock cycle}$
- <2> High-level pulse width = $(10000H \times \text{Number of times OVF00 bit is set to 1} + \text{Captured value of CR000}) \times \text{Count clock cycle}$
- <3> Low-level pulse width = $(\text{Pulse cycle} - \text{High-level pulse width})$

Figure 6-51. Example of Register Settings for Pulse Width Measurement (1/2)

(a) 16-bit timer mode control register 00 (TMC00)

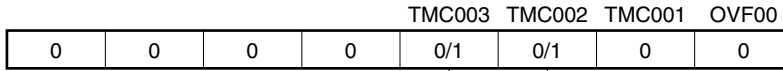

01: Free running timer mode
 10: Clear and start mode entered by valid edge of TI000 pin.

(b) Capture/compare control register 00 (CRC00)

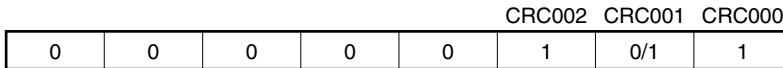

1: CR000 used as capture register
 0: TI01n pin is used as capture trigger of CR000.
 1: Reverse phase of TI000 pin is used as capture trigger of CR000.
 1: CR010 used as capture register

(c) 16-bit timer output control register 00 (TOC00)

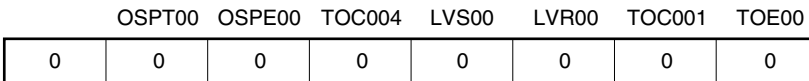

(d) Prescaler mode register 00 (PRM00)

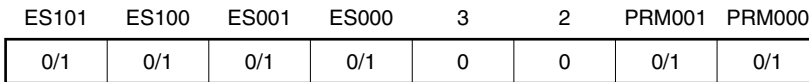

Selects count clock (setting valid edge of TI000 is prohibited)
 00: Falling edge detection
 01: Rising edge detection
 10: Setting prohibited
 11: Both edges detection (setting when CRC001 = 1 is prohibited)
 00: Falling edge detection
 01: Rising edge detection
 10: Setting prohibited
 11: Both edges detection

Figure 6-51. Example of Register Settings for Pulse Width Measurement (2/2)**(e) 16-bit timer counter 00 (TM00)**

By reading TM00, the count value can be read.

(f) 16-bit capture/compare register 000 (CR000)

This register is used as a capture register. Either the TI000 or TI010 pin is selected as a capture trigger. When a specified edge of the capture trigger is detected, the count value of TM00 is stored in CR000.

(g) 16-bit capture/compare register 010 (CR010)

This register is used as a capture register. The signal input to the TI000 pin is used as a capture trigger. When the capture trigger is detected, the count value of TM00 is stored in CR010.

Figure 6-52. Example of Software Processing for Pulse Width Measurement (1/2)

(a) Example of free-running timer mode

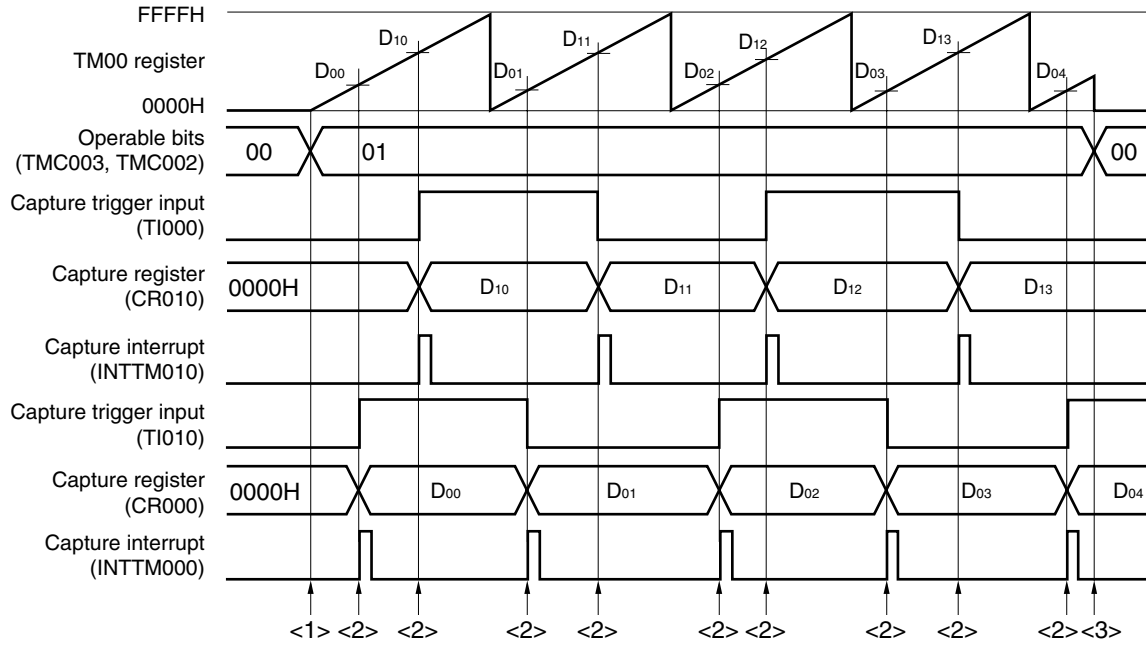

(b) Example of clear & start mode entered by TI000 pin valid edge

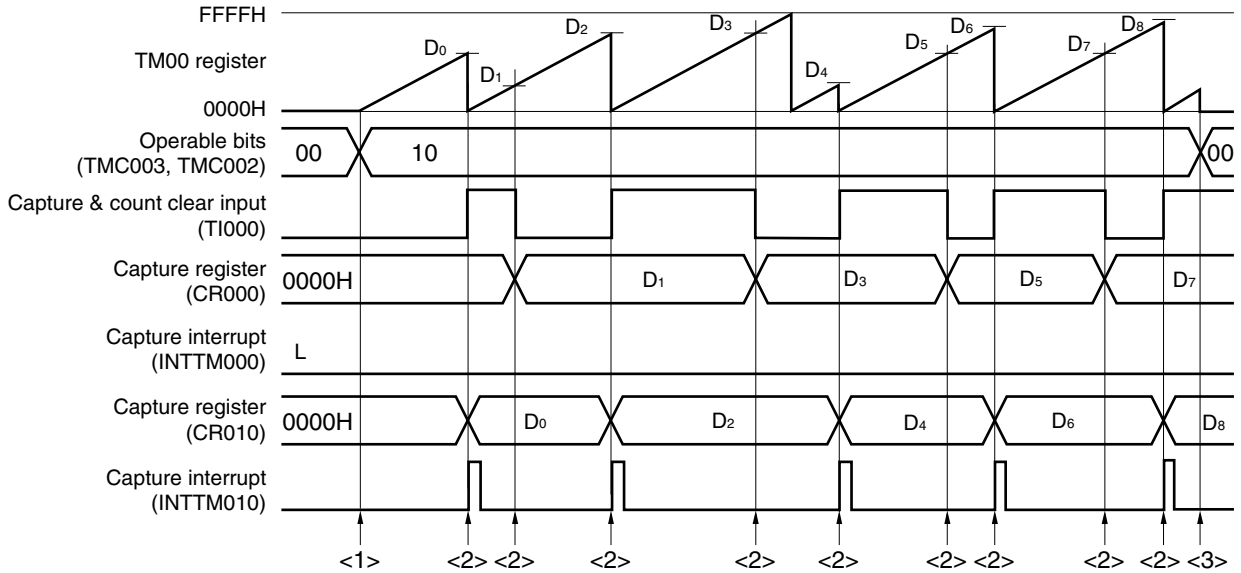
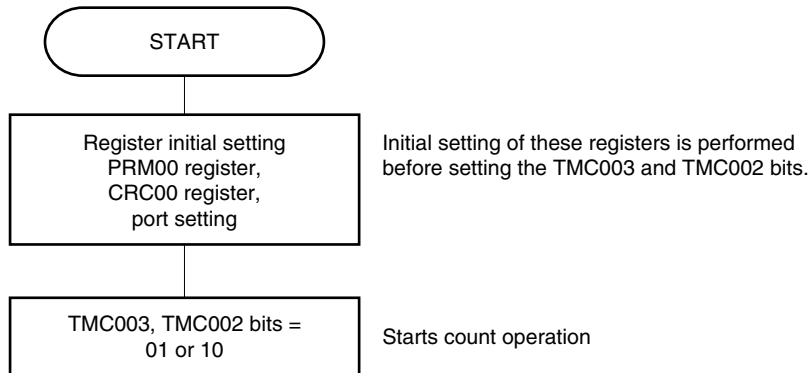
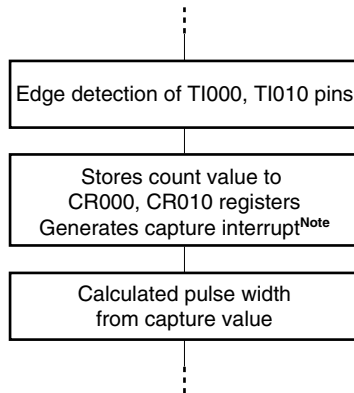

Figure 6-52. Example of Software Processing for Pulse Width Measurement (2/2)

<1> Count operation start flow



<2> Capture trigger input flow



<3> Count operation stop flow

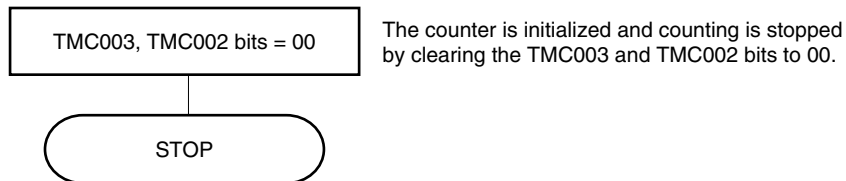

Note The capture interrupt signal (INTTM000) is not generated when the reverse-phase edge of the TI000 pin input is selected to the valid edge of CR000.

6.5 Special Use of TM00

6.5.1 Rewriting CR010 during TM00 operation

In principle, rewriting CR000 and CR010 of the 78K0/KB2 when they are used as compare registers is prohibited while TM00 is operating (TMC003 and TMC002 = other than 00).

However, the value of CR010 can be changed, even while TM00 is operating, using the following procedure if CR010 is used for PPG output and the duty factor is changed (change the value of CR010 immediately after its value matches the value of TM00. If the value of CR010 is changed immediately before its value matches TM00, an unexpected operation may be performed).

Procedure for changing value of CR010

- <1> Disable interrupt INTTM010 (TMMK010 = 1).
- <2> Disable reversal of the timer output when the value of TM00 matches that of CR010 (TOC004 = 0).
- <3> Change the value of CR010.
- <4> Wait for one cycle of the count clock of TM00.
- <5> Enable reversal of the timer output when the value of TM00 matches that of CR010 (TOC004 = 1).
- <6> Clear the interrupt flag of INTTM010 (TMIF010 = 0) to 0.
- <7> Enable interrupt INTTM010 (TMMK010 = 0).

Remark For TMIF010 and TMMK010, see **CHAPTER 15 INTERRUPT FUNCTIONS**.

6.5.2 Setting LVS00 and LVR00

(1) Usage of LVS00 and LVR00

LVS00 and LVR00 are used to set the default value of the TO00 pin output and to invert the timer output without enabling the timer operation (TMC003 and TMC002 = 00). Clear LVS00 and LVR00 to 00 (default value: low-level output) when software control is unnecessary.

LVS00	LVR00	Timer Output Status
0	0	Not changed (low-level output)
0	1	Cleared (low-level output)
1	0	Set (high-level output)
1	1	Setting prohibited

(2) Setting LVS00 and LVR00

Set LVS00 and LVR00 using the following procedure.

Figure 6-53. Example of Flow for Setting LVS00 and LVR00 Bits

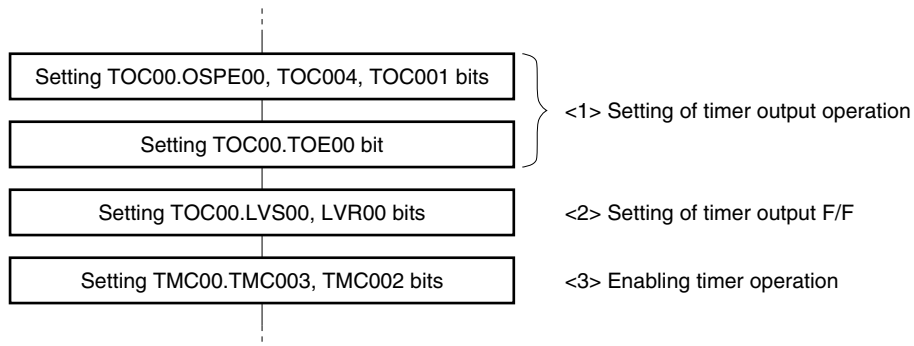

Caution Be sure to set LVS00 and LVR00 following steps <1>, <2>, and <3> above. Step <2> can be performed after <1> and before <3>.

Figure 6-54. Timing Example of LVR00 and LVS00

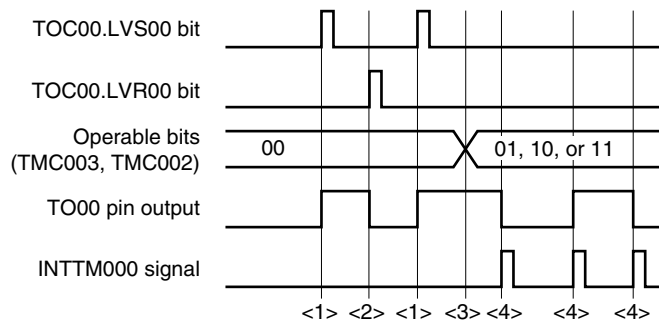

- <1> The TO00 pin output goes high when LVS00 and LVR00 = 10.
- <2> The TO00 pin output goes low when LVS00 and LVR00 = 01 (the pin output remains unchanged from the high level even if LVS00 and LVR00 are cleared to 00).
- <3> The timer starts operating when TMC003 and TMC002 are set to 01, 10, or 11. Because LVS00 and LVR00 were set to 10 before the operation was started, the TO00 pin output starts from the high level. After the timer starts operating, setting LVS00 and LVR00 is prohibited until TMC003 and TMC002 = 00 (disabling the timer operation).
- <4> The output level of the TO00 pin is inverted each time an interrupt signal (INTTM000) is generated.

6.6 Cautions for 16-Bit Timer/Event Counter 00

(1) Restrictions for each channel of 16-bit timer/event counter 00

Table 6-3 shows the restrictions for each channel.

Table 6-3. Restrictions for Each Channel of 16-Bit Timer/Event Counter 00

Operation	Restriction
As interval timer	-
As square wave output	
As external event counter	
As clear & start mode entered by TI000 pin valid edge input	Using timer output (TO00) is prohibited when detection of the valid edge of the TI010 pin is used. (TOC00 = 00H)
As free-running timer	-
As PPG output	$0000H \leq CR010 < CR000 \leq FFFFH$
As one-shot pulse output	Setting the same value to CR000 and CR010 is prohibited.
As pulse width measurement	Using timer output (TO00) is prohibited (TOC00 = 00H)

<R>

<R>

<R>

(2) Timer start errors

An error of up to one clock may occur in the time required for a match signal to be generated after timer start. This is because counting TM00 is started asynchronously to the count pulse.

Figure 6-55. Start Timing of TM00 Count

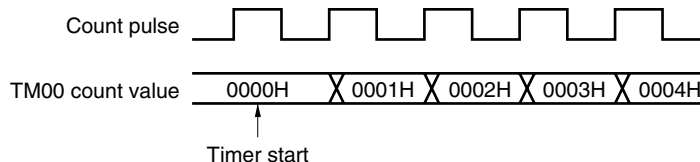

(3) Setting of CR000 and CR010 (clear & start mode entered upon a match between TM00 and CR000)

Set a value other than 0000H to CR000 and CR010 (TM00 cannot count one pulse when it is used as an external event counter).

(4) Timing of holding data by capture register

- (a) When the valid edge is input to the TI000/TI010 pin and the reverse phase of the TI000 pin is detected while CR000/CR010 is read, CR010 performs a capture operation but the read value of CR000/CR010 is not guaranteed. At this time, an interrupt signal (INTTM000/INTTM010) is generated when the valid edge of the TI000/TI010 pin is detected (the interrupt signal is not generated when the reverse-phase edge of the TI000 pin is detected).

When the count value is captured because the valid edge of the TI000/TI010 pin was detected, read the value of CR000/CR010 after INTTM000/INTTM010 is generated.

Figure 6-56. Timing of Holding Data by Capture Register

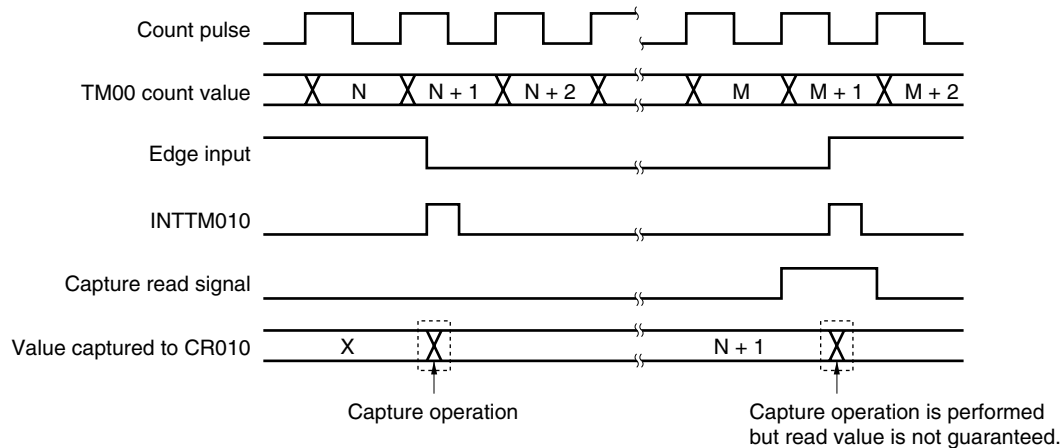

- (b) The values of CR000 and CR010 are not guaranteed after 16-bit timer/event counter 00 stops.

(5) Setting valid edge

Set the valid edge of the TI000 pin while the timer operation is stopped (TMC003 and TMC002 = 00). Set the valid edge by using ES000 and ES001.

(6) Re-triggering one-shot pulse

Make sure that the trigger is not generated while an active level is being output in the one-shot pulse output mode. Be sure to input the next trigger after the current active level is output.

(7) Operation of OVF00 flag**(a) Setting OVF00 flag (1)**

The OVF00 flag is set to 1 in the following case, as well as when TM00 overflows.

Select the clear & start mode entered upon a match between TM00 and CR000.

↓

Set CR000 to FFFFH.

↓

When TM00 matches CR000 and TM00 is cleared from FFFFH to 0000H

Figure 6-57. Operation Timing of OVF00 Flag

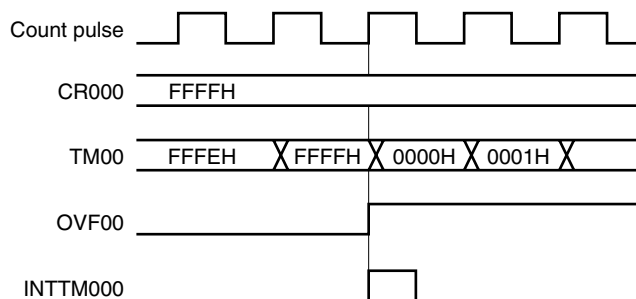
**(b) Clearing OVF00 flag**

Even if the OVF00 flag is cleared to 0 after TM00 overflows and before the next count clock is counted (before the value of TM00 becomes 0001H), it is set to 1 again and clearing is invalid.

(8) One-shot pulse output

One-shot pulse output operates correctly in the free-running timer mode or the clear & start mode entered by the TI000 pin valid edge. The one-shot pulse cannot be output in the clear & start mode entered upon a match between TM00 and CR000.

(9) Capture operation**(a) When valid edge of TI000 is specified as count clock**

When the valid edge of TI000 is specified as the count clock, the capture register for which TI000 is specified as a trigger does not operate correctly.

(b) Pulse width to accurately capture value by signals input to TI010 and TI000 pins

To accurately capture the count value, the pulse input to the TI000 and TI010 pins as a capture trigger must be wider than two count clocks selected by PRM00 (see **Figure 6-7**).

(c) Generation of interrupt signal

The capture operation is performed at the falling edge of the count clock but the interrupt signals (INTTM000 and INTTM010) are generated at the rising edge of the next count clock (see **Figure 6-7**).

(d) Note when CRC001 (bit 1 of capture/compare control register 00 (CRC00)) is set to 1

When the count value of the TM00 register is captured to the CR000 register in the phase reverse to the signal input to the TI000 pin, the interrupt signal (INTTM000) is not generated after the count value is captured. If the valid edge is detected on the TI010 pin during this operation, the capture operation is not performed but the INTTM000 signal is generated as an external interrupt signal. Mask the INTTM000 signal when the external interrupt is not used.

(10) Edge detection**(a) Specifying valid edge after reset**

If the operation of the 16-bit timer/event counter 00 is enabled after reset and while the TI000 or TI010 pin is at high level and when the rising edge or both the edges are specified as the valid edge of the TI000 or TI010 pin, then the high level of the TI000 or TI010 pin is detected as the rising edge. Note this when the TI000 or TI010 pin is pulled up. However, the rising edge is not detected when the operation is once stopped and then enabled again.

(b) Sampling clock for eliminating noise

The sampling clock for eliminating noise differs depending on whether the valid edge of TI000 is used as the count clock or capture trigger. In the former case, the sampling clock is fixed to f_{PRS} . In the latter, the count clock selected by PRM00 is used for sampling.

When the signal input to the TI000 pin is sampled and the valid level is detected two times in a row, the valid edge is detected. Therefore, noise having a short pulse width can be eliminated (see **Figure 6-7**).

(11) Timer operation

The signal input to the TI000/TI010 pin is not acknowledged while the timer is stopped, regardless of the operation mode of the CPU.

Remark f_{PRS} : Peripheral hardware clock frequency

CHAPTER 7 8-BIT TIMER/EVENT COUNTERS 50 AND 51

7.1 Functions of 8-Bit Timer/Event Counters 50 and 51

8-bit timer/event counters 50 and 51 have the following functions.

- Interval timer
- External event counter
- Square-wave output
- PWM output

7.2 Configuration of 8-Bit Timer/Event Counters 50 and 51

8-bit timer/event counters 50 and 51 include the following hardware.

Table 7-1. Configuration of 8-Bit Timer/Event Counters 50 and 51

Item	Configuration
Timer register	8-bit timer counter 5n (TM5n)
Register	8-bit timer compare register 5n (CR5n)
Timer input	TI5n
Timer output	TO5n
Control registers	Timer clock selection register 5n (TCL5n) 8-bit timer mode control register 5n (TMC5n) Port mode register 1 (PM1) or port mode register 3 (PM3) Port register 1 (P1) or port register 3 (P3)

Figures 7-1 and 7-2 show the block diagrams of 8-bit timer/event counters 50 and 51.

Figure 7-1. Block Diagram of 8-Bit Timer/Event Counter 50

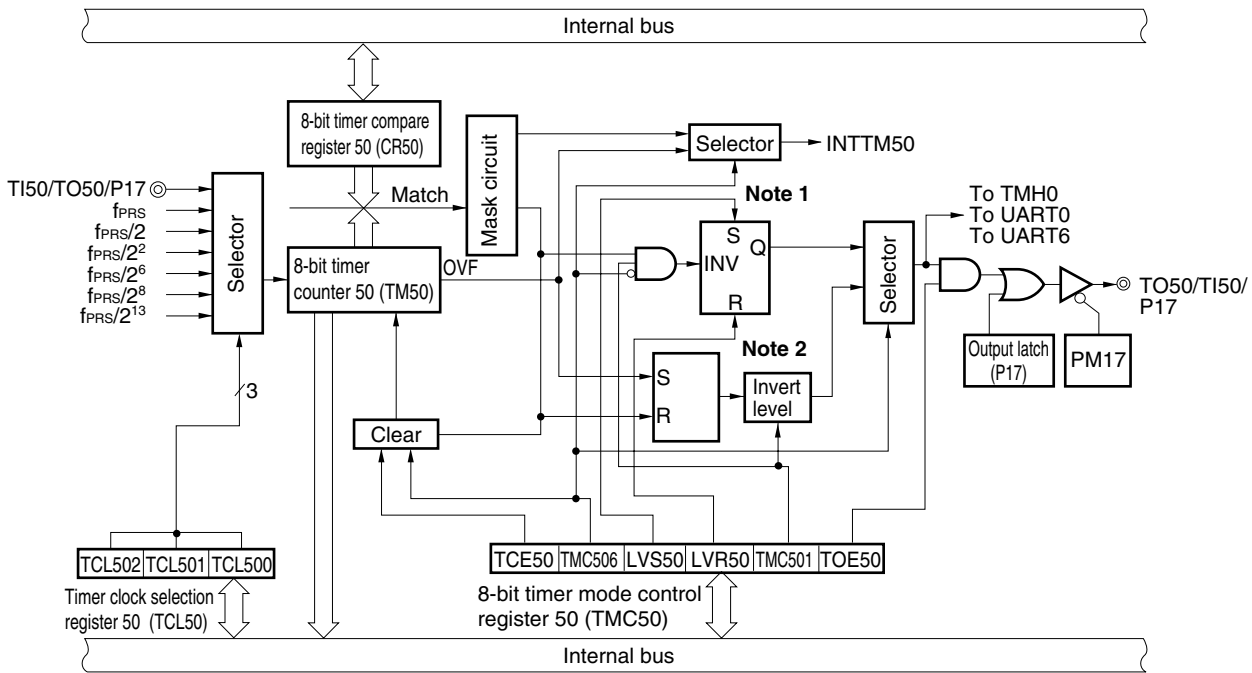
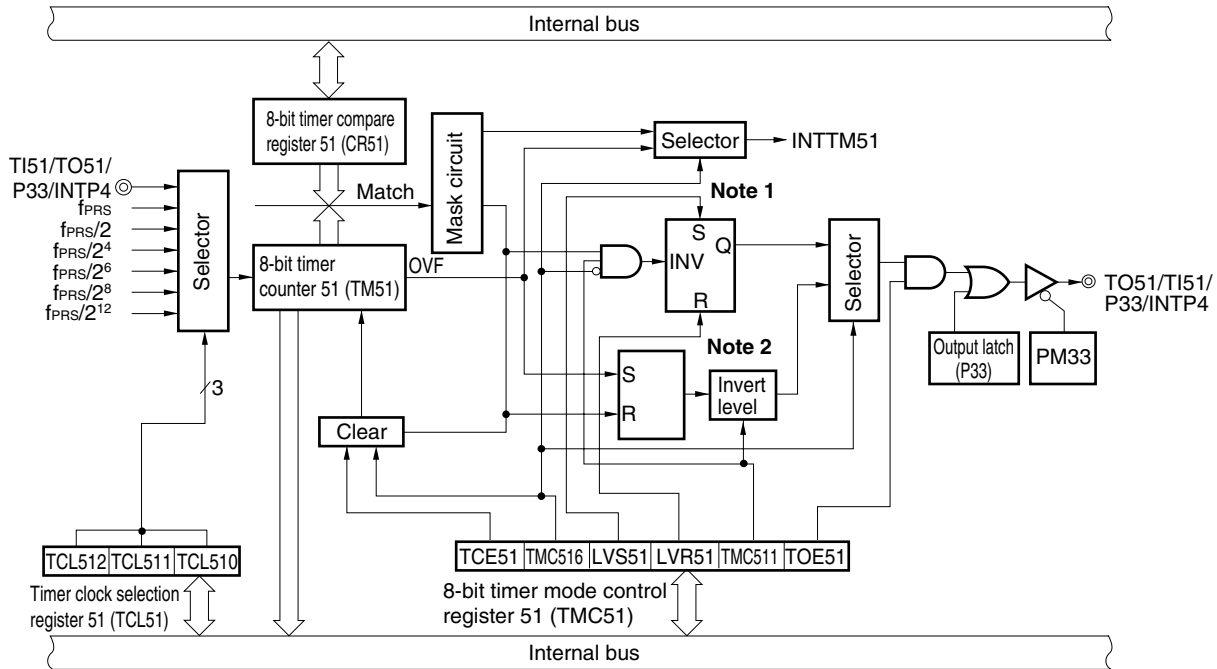

Figure 7-2. Block Diagram of 8-Bit Timer/Event Counter 51



- Notes**
1. Timer output F/F
 2. PWM output F/F

(1) 8-bit timer counter 5n (TM5n)

TM5n is an 8-bit register that counts the count pulses and is read-only.

The counter is incremented in synchronization with the rising edge of the count clock.

Figure 7-3. Format of 8-Bit Timer Counter 5n (TM5n)

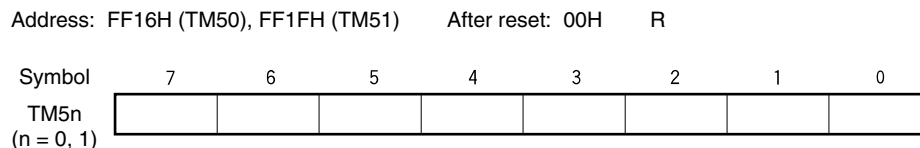

In the following situations, the count value is cleared to 00H.

- <1> Reset signal generation
- <2> When TCE5n is cleared
- <3> When TM5n and CR5n match in the mode in which clear & start occurs upon a match of the TM5n and CR5n.

(2) 8-bit timer compare register 5n (CR5n)

CR5n can be read and written by an 8-bit memory manipulation instruction.

Except in PWM mode, the value set in CR5n is constantly compared with the 8-bit timer counter 5n (TM5n) count value, and an interrupt request (INTTM5n) is generated if they match.

In the PWM mode, the TO5n pin becomes inactive when the values of TM5n and CR5n match, but no interrupt is generated.

The value of CR5n can be set within 00H to FFH.

Reset signal generation sets CR5n to 00H.

Figure 7-4. Format of 8-Bit Timer Compare Register 5n (CR5n)

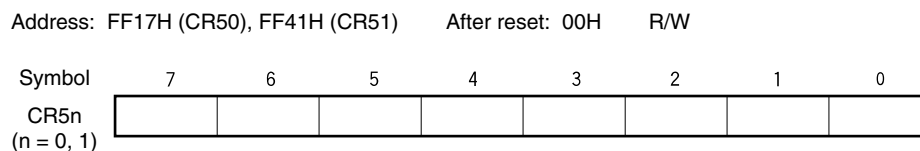

- Cautions**
1. In the mode in which clear & start occurs on a match of TM5n and CR5n (TMC5n6 = 0), do not write other values to CR5n during operation.
 2. In PWM mode, make the CR5n rewrite period 3 count clocks of the count clock (clock selected by TCL5n) or more.

Remark n = 0, 1

7.3 Registers Controlling 8-Bit Timer/Event Counters 50 and 51

The following four registers are used to control 8-bit timer/event counters 50 and 51.

- Timer clock selection register 5n (TCL5n)
- 8-bit timer mode control register 5n (TMC5n)
- Port mode register 1 (PM1) or port mode register 3 (PM3)
- Port register 1 (P1) or port register 3 (P3)

(1) Timer clock selection register 5n (TCL5n)

This register sets the count clock of 8-bit timer/event counter 5n and the valid edge of the TI5n pin input.

TCL5n can be set by a 1-bit or 8-bit memory manipulation instruction.

Reset signal generation sets TCL5n to 00H.

Remark n = 0, 1

Figure 7-5. Format of Timer Clock Selection Register 50 (TCL50)

Address: FF6AH After reset: 00H R/W

Symbol	7	6	5	4	3	2	1	0
TCL50	0	0	0	0	0	TCL502	TCL501	TCL500

TCL502	TCL501	TCL500	Count clock selection				
			$f_{PRS} =$ 2 MHz	$f_{PRS} =$ 5 MHz	$f_{PRS} =$ 10 MHz	$f_{PRS} =$ 20 MHz	
0	0	0	TI50 pin falling edge				
0	0	1	TI50 pin rising edge				
0	1	0	f_{PRS}	2 MHz	5 MHz	10 MHz	20 MHz
0	1	1	$f_{PRS}/2$	1 MHz	2.5 MHz	5 MHz	10 MHz
1	0	0	$f_{PRS}/2^2$	500 kHz	1.25 MHz	2.5 MHz	5 MHz
1	0	1	$f_{PRS}/2^6$	31.25 kHz	78.13 kHz	156.25 kHz	312.5 kHz
1	1	0	$f_{PRS}/2^8$	7.81 kHz	19.53 kHz	39.06 kHz	78.13 kHz
1	1	1	$f_{PRS}/2^{13}$	0.24 kHz	0.61 kHz	1.22 kHz	2.44 kHz

- Cautions**
1. When rewriting TCL50 to other data, stop the timer operation beforehand.
 2. Be sure to clear bits 3 to 7 to 0.

Remark f_{PRS} : Peripheral hardware clock frequency

Figure 7-6. Format of Timer Clock Selection Register 51 (TCL51)

Address: FF8CH After reset: 00H R/W

Symbol	7	6	5	4	3	2	1	0
TCL51	0	0	0	0	0	TCL512	TCL511	TCL510

TCL512	TCL511	TCL510	Count clock selection				
			f _{PRS} = 2 MHz	f _{PRS} = 5 MHz	f _{PRS} = 10 MHz	f _{PRS} = 20 MHz	
0	0	0	TI51 pin falling edge				
0	0	1	TI51 pin rising edge				
0	1	0	f _{PRS}	2 MHz	5 MHz	10 MHz	20 MHz
0	1	1	f _{PRS} /2	1 MHz	2.5 MHz	5 MHz	10 MHz
1	0	0	f _{PRS} /2 ⁴	125 kHz	312.5 kHz	625 kHz	1.25 MHz
1	0	1	f _{PRS} /2 ⁶	31.25 kHz	78.13 kHz	156.25 kHz	312.5 kHz
1	1	0	f _{PRS} /2 ⁸	7.81 kHz	19.53 kHz	39.06 kHz	78.13 kHz
1	1	1	f _{PRS} /2 ¹²	0.49 kHz	1.22 kHz	2.44 kHz	4.88 kHz

- Cautions**
1. When rewriting TCL51 to other data, stop the timer operation beforehand.
 2. Be sure to clear bits 3 to 7 to 0.

Remark f_{PRS}: Peripheral hardware clock frequency

(2) 8-bit timer mode control register 5n (TMC5n)

TMC5n is a register that performs the following five types of settings.

- <1> 8-bit timer counter 5n (TM5n) count operation control
- <2> 8-bit timer counter 5n (TM5n) operating mode selection
- <3> Timer output F/F (flip flop) status setting
- <4> Active level selection in timer F/F control or PWM (free-running) mode.
- <5> Timer output control

TMC5n can be set by a 1-bit or 8-bit memory manipulation instruction.

Reset signal generation sets this register to 00H.

Remark n = 0, 1

Figure 7-7. Format of 8-Bit Timer Mode Control Register 50 (TMC50)

Address: FF6BH After reset: 00H R/W^{Note}

Symbol	<7>	6	5	4	<3>	<2>	1	<0>																				
TMC50	TCE50	TMC506	0	0	LVS50	LVR50	TMC501	TOE50																				
	<table border="1"> <thead> <tr> <th>TCE50</th> <th colspan="2">TM50 count operation control</th> </tr> </thead> <tbody> <tr> <td>0</td> <td colspan="2">After clearing to 0, count operation disabled (counter stopped)</td> </tr> <tr> <td>1</td> <td colspan="2">Count operation start</td> </tr> </tbody> </table>								TCE50	TM50 count operation control		0	After clearing to 0, count operation disabled (counter stopped)		1	Count operation start												
TCE50	TM50 count operation control																											
0	After clearing to 0, count operation disabled (counter stopped)																											
1	Count operation start																											
	<table border="1"> <thead> <tr> <th>TMC506</th> <th colspan="2">TM50 operating mode selection</th> </tr> </thead> <tbody> <tr> <td>0</td> <td colspan="2">Mode in which clear & start occurs on a match between TM50 and CR50</td> </tr> <tr> <td>1</td> <td colspan="2">PWM (free-running) mode</td> </tr> </tbody> </table>								TMC506	TM50 operating mode selection		0	Mode in which clear & start occurs on a match between TM50 and CR50		1	PWM (free-running) mode												
TMC506	TM50 operating mode selection																											
0	Mode in which clear & start occurs on a match between TM50 and CR50																											
1	PWM (free-running) mode																											
	<table border="1"> <thead> <tr> <th>LVS50</th> <th>LVR50</th> <th colspan="2">Timer output F/F status setting</th> </tr> </thead> <tbody> <tr> <td>0</td> <td>0</td> <td colspan="2">No change</td> </tr> <tr> <td>0</td> <td>1</td> <td colspan="2">Timer output F/F clear (0) (default output value of TO50 pin: low level)</td> </tr> <tr> <td>1</td> <td>0</td> <td colspan="2">Timer output F/F set (1) (default output value of TO50 pin: high level)</td> </tr> <tr> <td>1</td> <td>1</td> <td colspan="2">Setting prohibited</td> </tr> </tbody> </table>								LVS50	LVR50	Timer output F/F status setting		0	0	No change		0	1	Timer output F/F clear (0) (default output value of TO50 pin: low level)		1	0	Timer output F/F set (1) (default output value of TO50 pin: high level)		1	1	Setting prohibited	
LVS50	LVR50	Timer output F/F status setting																										
0	0	No change																										
0	1	Timer output F/F clear (0) (default output value of TO50 pin: low level)																										
1	0	Timer output F/F set (1) (default output value of TO50 pin: high level)																										
1	1	Setting prohibited																										
	<table border="1"> <thead> <tr> <th rowspan="2">TMC501</th> <th colspan="2">In other modes (TMC506 = 0)</th> <th colspan="2">In PWM mode (TMC506 = 1)</th> </tr> <tr> <th colspan="2">Timer F/F control</th> <th colspan="2">Active level selection</th> </tr> </thead> <tbody> <tr> <td>0</td> <td colspan="2">Inversion operation disabled</td> <td colspan="2">Active-high</td> </tr> <tr> <td>1</td> <td colspan="2">Inversion operation enabled</td> <td colspan="2">Active-low</td> </tr> </tbody> </table>								TMC501	In other modes (TMC506 = 0)		In PWM mode (TMC506 = 1)		Timer F/F control		Active level selection		0	Inversion operation disabled		Active-high		1	Inversion operation enabled		Active-low		
TMC501	In other modes (TMC506 = 0)		In PWM mode (TMC506 = 1)																									
	Timer F/F control		Active level selection																									
0	Inversion operation disabled		Active-high																									
1	Inversion operation enabled		Active-low																									
	<table border="1"> <thead> <tr> <th>TOE50</th> <th colspan="2">Timer output control</th> </tr> </thead> <tbody> <tr> <td>0</td> <td colspan="2">Output disabled (TM50 output is low level)</td> </tr> <tr> <td>1</td> <td colspan="2">Output enabled</td> </tr> </tbody> </table>								TOE50	Timer output control		0	Output disabled (TM50 output is low level)		1	Output enabled												
TOE50	Timer output control																											
0	Output disabled (TM50 output is low level)																											
1	Output enabled																											

Note Bits 2 and 3 are write-only.

(**Cautions** and **Remarks** are listed on the next page.)

Figure 7-8. Format of 8-Bit Timer Mode Control Register 51 (TMC51)

Address: FF43H After reset: 00H R/W^{Note}

Symbol	<7>	6	5	4	<3>	<2>	1	<0>	
TMC51	TCE51	TMC516	0	0	LVS51	LVR51	TMC511	TOE51	
TCE51	TM51 count operation control								
0	After clearing to 0, count operation disabled (counter stopped)								
1	Count operation start								
TMC516	TM51 operating mode selection								
0	Mode in which clear & start occurs on a match between TM51 and CR51								
1	PWM (free-running) mode								
LVS51	LVR51	Timer output F/F status setting							
0	0	No change							
0	1	Timer output F/F clear (0) (default output value of TO51 pin: low)							
1	0	Timer output F/F set (1) (default output value of TO51 pin: high)							
1	1	Setting prohibited							
TMC511	In other modes (TMC516 = 0)				In PWM mode (TMC516 = 1)				
	Timer F/F control				Active level selection				
0	Inversion operation disabled				Active-high				
1	Inversion operation enabled				Active-low				
TOE51	Timer output control								
0	Output disabled (TM51 output is low level)								
1	Output enabled								

Note Bits 2 and 3 are write-only.

- Cautions**
1. The settings of LVS5n and LVR5n are valid in other than PWM mode.
 2. Perform <1> to <4> below in the following order, not at the same time.
 - <1> Set TMC5n1, TMC5n6: Operation mode setting
 - <2> Set TOE5n to enable output: Timer output enable
 - <3> Set LVS5n, LVR5n (see Caution 1): Timer F/F setting
 - <4> Set TCE5n
 3. When TCE5n = 1, setting the other bits of TMC5n is prohibited.

<R>

- Remarks**
1. In PWM mode, PWM output is made inactive by clearing TCE5n to 0.
 2. If LVS5n and LVR5n are read, the value is 0.
 3. The values of the TMC5n6, LVS5n, LVR5n, TMC5n1, and TOE5n bits are reflected at the TO5n pin regardless of the value of TCE5n.
 4. n = 0, 1

(3) Port mode registers 1 and 3 (PM1, PM3)

These registers set port 1 and 3 input/output in 1-bit units.

When using the P17/TO50/TI50 and P33/TO51/TI51/INTP4 pins for timer output, clear PM17 and PM33 and the output latches of P17 and P33 to 0.

When using the P17/TO50/TI50 and P33/TO51/TI51/INTP4 pins for timer input, set PM17 and PM33 to 1. The output latches of P17 and P33 at this time may be 0 or 1.

PM1 and PM3 can be set by a 1-bit or 8-bit memory manipulation instruction.

Reset signal generation sets these registers to FFH.

Figure 7-9. Format of Port Mode Register 1 (PM1)

Address: FF21H After reset: FFH R/W

Symbol	7	6	5	4	3	2	1	0
PM1	PM17	PM16	PM15	PM14	PM13	PM12	PM11	PM10

PM1n	P1n pin I/O mode selection (n = 0 to 7)
0	Output mode (output buffer on)
1	Input mode (output buffer off)

Figure 7-10. Format of Port Mode Register 3 (PM3)

Address: FF23H After reset: FFH R/W

Symbol	7	6	5	4	3	2	1	0
PM3	1	1	1	1	PM33	PM32	PM31	PM30

PM3n	P3n pin I/O mode selection (n = 0 to 3)
0	Output mode (output buffer on)
1	Input mode (output buffer off)

7.4 Operations of 8-Bit Timer/Event Counters 50 and 51

7.4.1 Operation as interval timer

8-bit timer/event counter 5n operates as an interval timer that generates interrupt requests repeatedly at intervals of the count value preset to 8-bit timer compare register 5n (CR5n).

When the count value of 8-bit timer counter 5n (TM5n) matches the value set to CR5n, counting continues with the TM5n value cleared to 0 and an interrupt request signal (INTTM5n) is generated.

The count clock of TM5n can be selected with bits 0 to 2 (TCL5n0 to TCL5n2) of timer clock selection register 5n (TCL5n).

Setting

<1> Set the registers.

- TCL5n: Select the count clock.
- CR5n: Compare value
- TMC5n: Stop the count operation, select the mode in which clear & start occurs on a match of TM5n and CR5n.

(TMC5n = 0000xxx0B x = Don't care)

<2> After TCE5n = 1 is set, the count operation starts.

<3> If the values of TM5n and CR5n match, INTTM5n is generated (TM5n is cleared to 00H).

<4> INTTM5n is generated repeatedly at the same interval.

Set TCE5n to 0 to stop the count operation.

Caution Do not write other values to CR5n during operation.

Remarks 1. For how to enable the INTTM5n signal interrupt, see **CHAPTER 15 INTERRUPT FUNCTIONS**.

2. n = 0, 1

Figure 7-11. Interval Timer Operation Timing (1/2)

(a) Basic operation

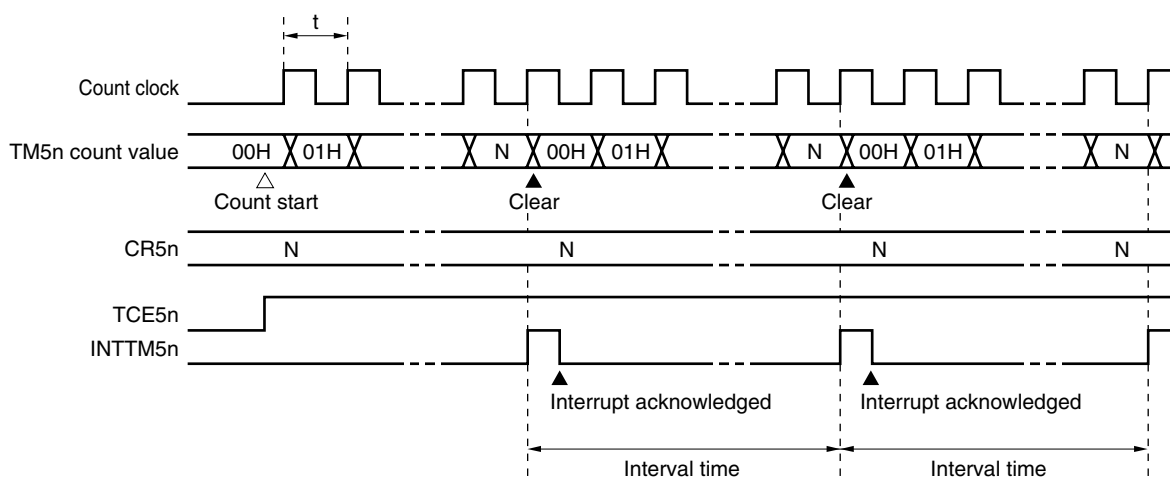

Remark Interval time = $(N + 1) \times t$

N = 01H to FFH

n = 0, 1

Figure 7-11. Interval Timer Operation Timing (2/2)

(b) When CR5n = 00H

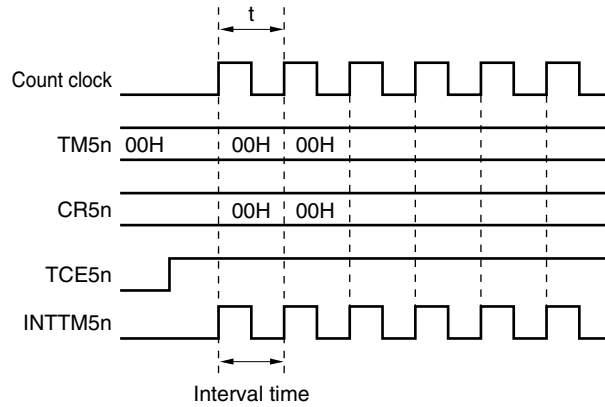

(c) When CR5n = FFH

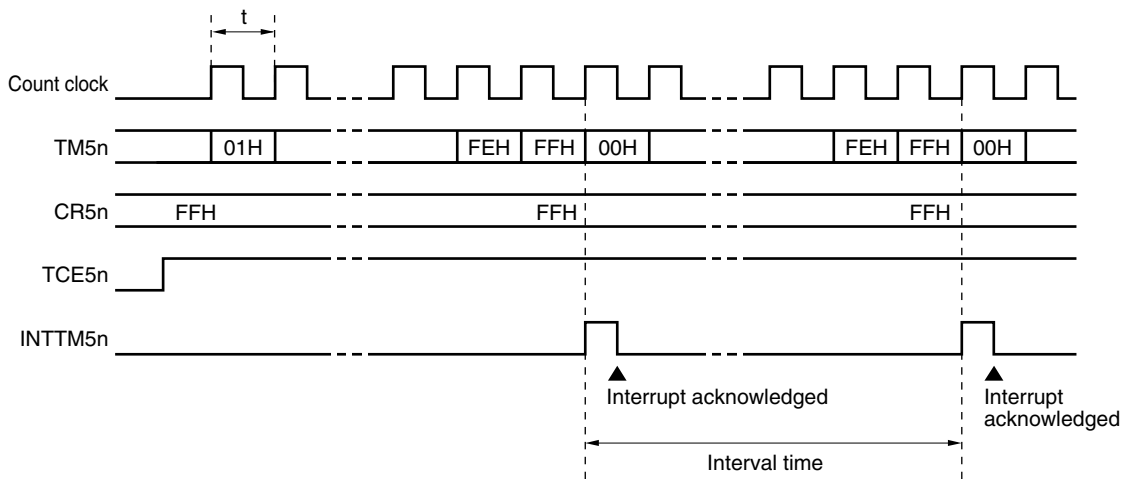

Remark n = 0, 1

7.4.2 Operation as external event counter

The external event counter counts the number of external clock pulses to be input to the TI5n pin by 8-bit timer counter 5n (TM5n).

TM5n is incremented each time the valid edge specified by timer clock selection register 5n (TCL5n) is input. Either the rising or falling edge can be selected.

When the TM5n count value matches the value of 8-bit timer compare register 5n (CR5n), TM5n is cleared to 0 and an interrupt request signal (INTTM5n) is generated.

Whenever the TM5n value matches the value of CR5n, INTTM5n is generated.

Setting

- <1> Set each register.
 - Set the port mode register (PM17 or PM33)^{Note} to 1.
 - TCL5n: Select TI5n pin input edge.
 TI5n pin falling edge → TCL5n = 00H
 TI5n pin rising edge → TCL5n = 01H
 - CR5n: Compare value
 - TMC5n: Stop the count operation, select the mode in which clear & start occurs on match of TM5n and CR5n, disable the timer F/F inversion operation, disable timer output.
 (TMC5n = 0000000B)
- <2> When TCE5n = 1 is set, the number of pulses input from the TI5n pin is counted.
- <3> When the values of TM5n and CR5n match, INTTM5n is generated (TM5n is cleared to 00H).
- <4> After these settings, INTTM5n is generated each time the values of TM5n and CR5n match.

<R>

Note 8-bit timer/event counter 50: PM17
 8-bit timer/event counter 51: PM33

Remark For how to enable the INTTM5n signal interrupt, see **CHAPTER 15 INTERRUPT FUNCTIONS**.

Figure 7-12. External Event Counter Operation Timing (with Rising Edge Specified)

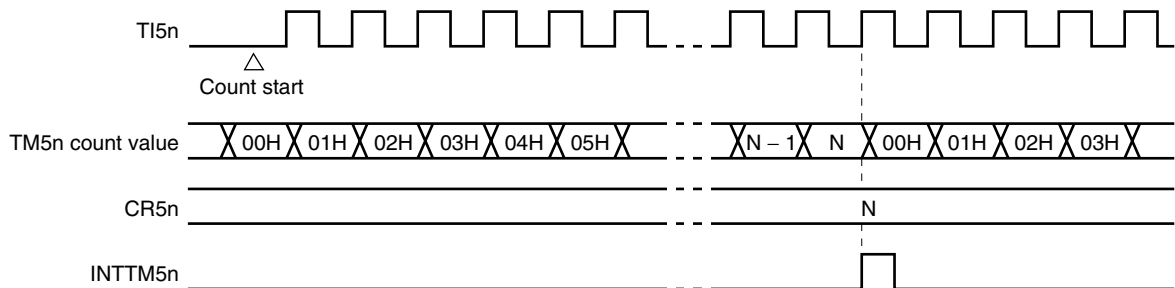

Remark N = 00H to FFH
 n = 0, 1

7.4.3 Square-wave output operation

A square wave with any selected frequency is output at intervals determined by the value preset to 8-bit timer compare register 5n (CR5n).

The TO5n pin output status is inverted at intervals determined by the count value preset to CR5n by setting bit 0 (TOE5n) of 8-bit timer mode control register 5n (TMC5n) to 1. This enables a square wave with any selected frequency to be output (duty = 50%).

Setting

<1> Set each register.

- Clear the port output latch (P17 or P33)^{Note} and port mode register (PM17 or PM33)^{Note} to 0.
- TCL5n: Select the count clock.
- CR5n: Compare value
- TMC5n: Stop the count operation, select the mode in which clear & start occurs on a match of TM5n and CR5n.

LVS5n	LVR5n	Timer Output F/F Status Setting
0	1	Timer output F/F clear (0) (default output value of TO50 pin: low level)
1	0	Timer output F/F set (1) (default output value of TO5n pin: high level)

Timer output enabled

(TMC5n = 00001011B or 00000111B)

<2> After TCE5n = 1 is set, the count operation starts.

<3> The timer output F/F is inverted by a match of TM5n and CR5n. After INTTM5n is generated, TM5n is cleared to 00H.

<4> After these settings, the timer output F/F is inverted at the same interval and a square wave is output from TO5n.

The frequency is as follows.

- Frequency = $1/2t(N + 1)$
(N: 00H to FFH)

Note 8-bit timer/event counter 50: P17, PM17

8-bit timer/event counter 51: P33, PM33

Caution Do not write other values to CR5n during operation.

Remarks 1. For how to enable the INTTM5n signal interrupt, see **CHAPTER 15 INTERRUPT FUNCTIONS**.

2. n = 0, 1

Figure 7-13. Square-Wave Output Operation Timing

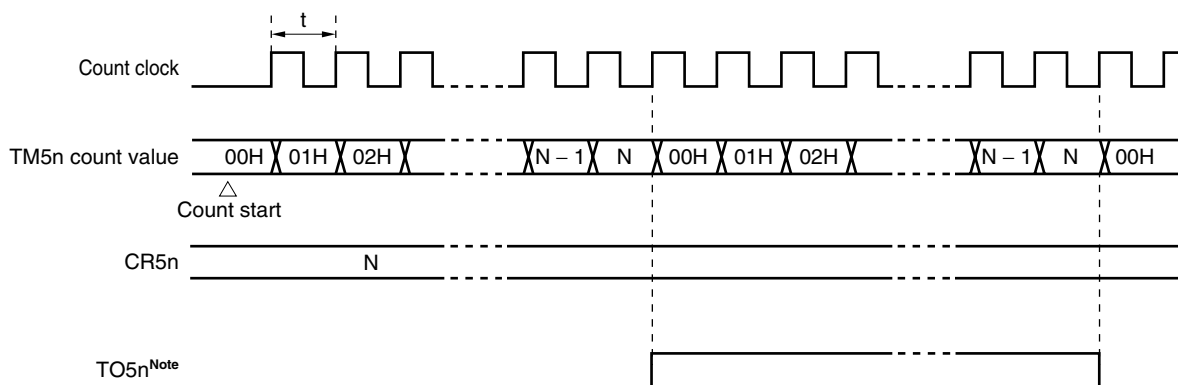

Note The initial value of TO5n output can be set by bits 2 and 3 (LVR5n, LVS5n) of 8-bit timer mode control register 5n (TMC5n).

7.4.4 PWM output operation

8-bit timer/event counter 5n operates as a PWM output when bit 6 (TMC5n6) of 8-bit timer mode control register 5n (TMC5n) is set to 1.

The duty pulse determined by the value set to 8-bit timer compare register 5n (CR5n) is output from TO5n.

Set the active level width of the PWM pulse to CR5n; the active level can be selected with bit 1 (TMC5n1) of TMC5n.

The count clock can be selected with bits 0 to 2 (TCL5n0 to TCL5n2) of timer clock selection register 5n (TCL5n).

PWM output can be enabled/disabled with bit 0 (TOE5n) of TMC5n.

Caution In PWM mode, make the CR5n rewrite period 3 count clocks of the count clock (clock selected by TCL5n) or more.

Remark n = 0, 1

(1) PWM output basic operation**Setting**

<1> Set each register.

- Clear the port output latch (P17 or P33)^{Note} and port mode register (PM17 or PM33)^{Note} to 0.
- TCL5n: Select the count clock.
- CR5n: Compare value
- TMC5n: Stop the count operation, select PWM mode.

The timer output F/F is not changed.

TMC5n1	Active Level Selection
0	Active-high
1	Active-low

Timer output enabled

(TMC5n = 01000001B or 01000011B)

<2> The count operation starts when TCE5n = 1.
Clear TCE5n to 0 to stop the count operation.

Note 8-bit timer/event counter 50: P17, PM17
8-bit timer/event counter 51: P33, PM33

PWM output operation

- <1> PWM output (output from TO5n) outputs an inactive level until an overflow occurs.
- <2> When an overflow occurs, the active level is output. The active level is output until CR5n matches the count value of 8-bit timer counter 5n (TM5n).
- <3> After the CR5n matches the count value, the inactive level is output until an overflow occurs again.
- <4> Operations <2> and <3> are repeated until the count operation stops.
- <5> When the count operation is stopped with TCE5n = 0, PWM output becomes inactive.

For details of timing, see **Figures 7-14** and **7-15**.

The cycle, active-level width, and duty are as follows.

- Cycle = $2^8 t$
- Active-level width = Nt
- Duty = $N/2^8$

(N = 00H to FFH)

Remark n = 0, 1

Figure 7-14. PWM Output Operation Timing

(a) Basic operation (active level = H)

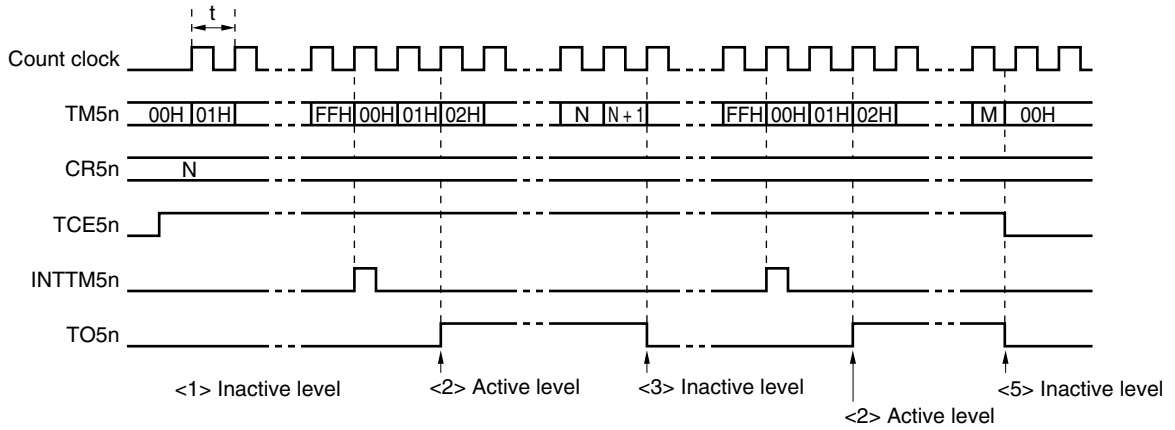

(b) CR5n = 00H

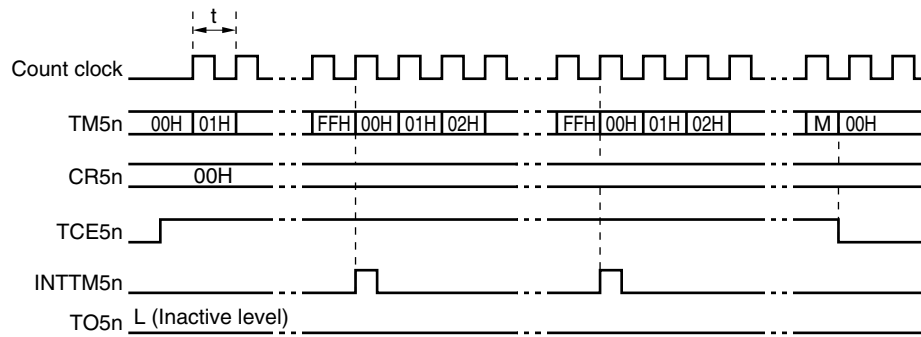

(c) CR5n = FFH

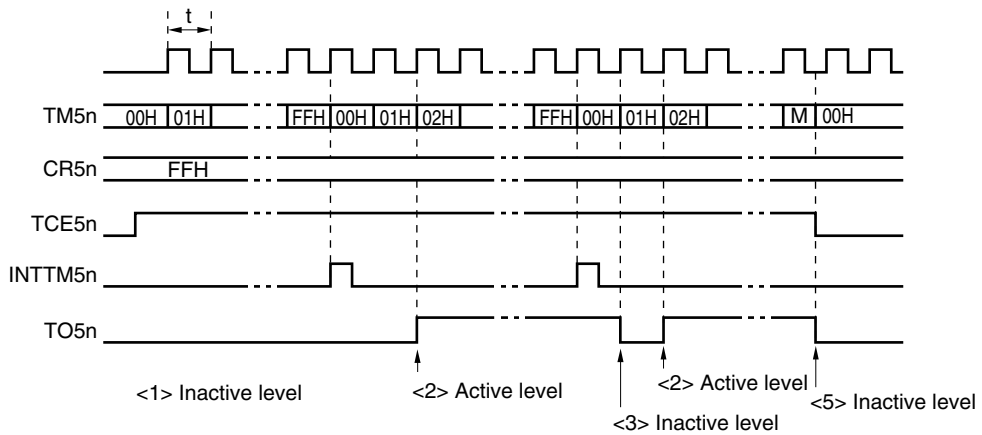

Remarks 1. <1> to <3> and <5> in Figure 7-14 (a) and (c) correspond to <1> to <3> and <5> in **PWM output operation** in 7.4.4 (1) **PWM output basic operation**.

2. n = 0, 1

(2) Operation with CR5n changed

Figure 7-15. Timing of Operation with CR5n Changed

- (a) CR5n value is changed from N to M before clock rising edge of FFH
 → Value is transferred to CR5n at overflow immediately after change.

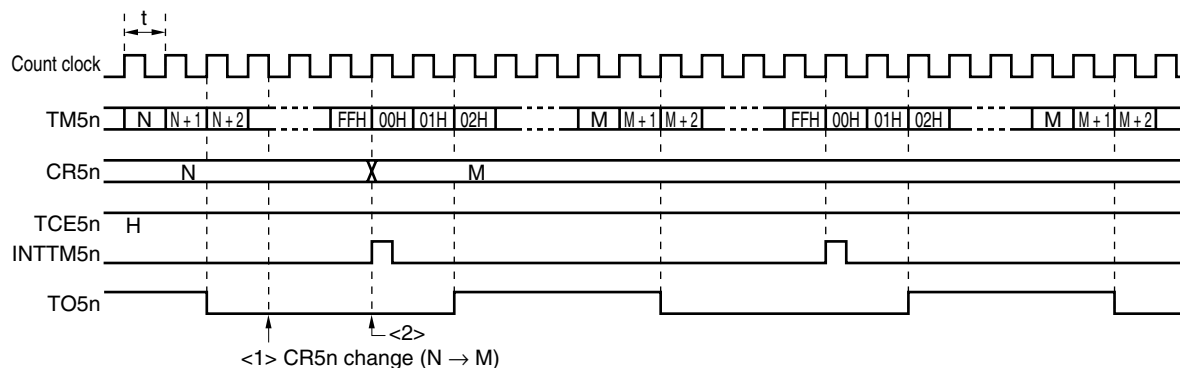

- (b) CR5n value is changed from N to M after clock rising edge of FFH
 → Value is transferred to CR5n at second overflow.

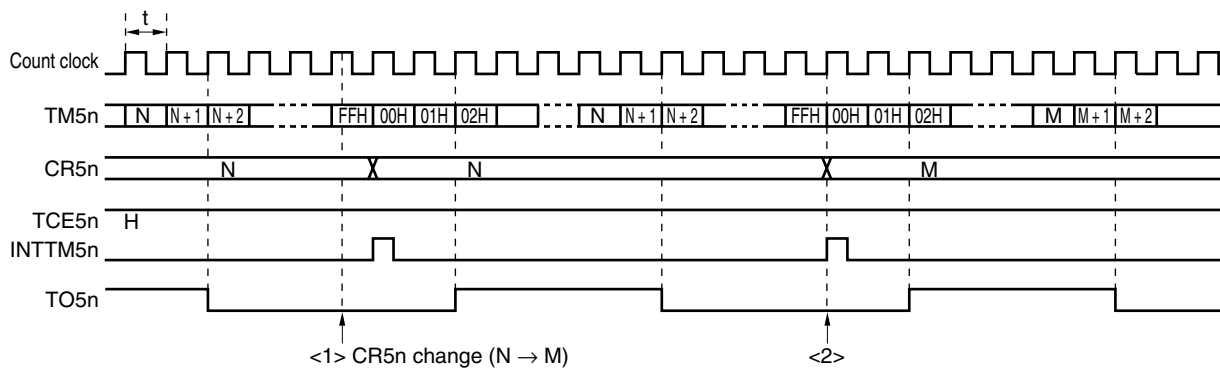

Caution When reading from CR5n between <1> and <2> in Figure 7-15, the value read differs from the actual value (read value: M, actual value of CR5n: N).

7.5 Cautions for 8-Bit Timer/Event Counters 50 and 51

(1) Timer start error

An error of up to one clock may occur in the time required for a match signal to be generated after timer start. This is because 8-bit timer counters 50 and 51 (TM50, TM51) are started asynchronously to the count clock.

Figure 7-16. 8-Bit Timer Counter 5n Start Timing

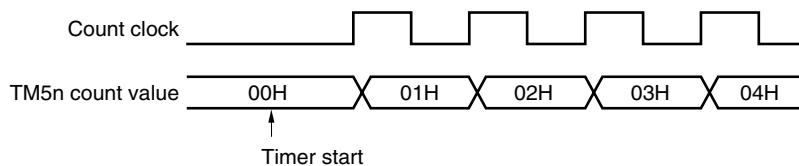

Remark $n = 0, 1$

CHAPTER 8 8-BIT TIMERS H0 AND H1

8.1 Functions of 8-Bit Timers H0 and H1

8-bit timers H0 and H1 have the following functions.

- Interval timer
- Square-wave output
- PWM output
- Carrier generator (8-bit timer H1 only)

8.2 Configuration of 8-Bit Timers H0 and H1

8-bit timers H0 and H1 include the following hardware.

Table 8-1. Configuration of 8-Bit Timers H0 and H1

Item	Configuration
Timer register	8-bit timer counter Hn
Registers	8-bit timer H compare register 0n (CMP0n) 8-bit timer H compare register 1n (CMP1n)
Timer output	TOHn, output controller
Control registers	8-bit timer H mode register n (TMHMDn) 8-bit timer H carrier control register 1 (TMCYC1) ^{Note} Port mode register 1 (PM1) Port register 1 (P1)

Note 8-bit timer H1 only

Remark n = 0, 1

Figures 8-1 and 8-2 show the block diagrams.

Figure 8-1. Block Diagram of 8-Bit Timer H0

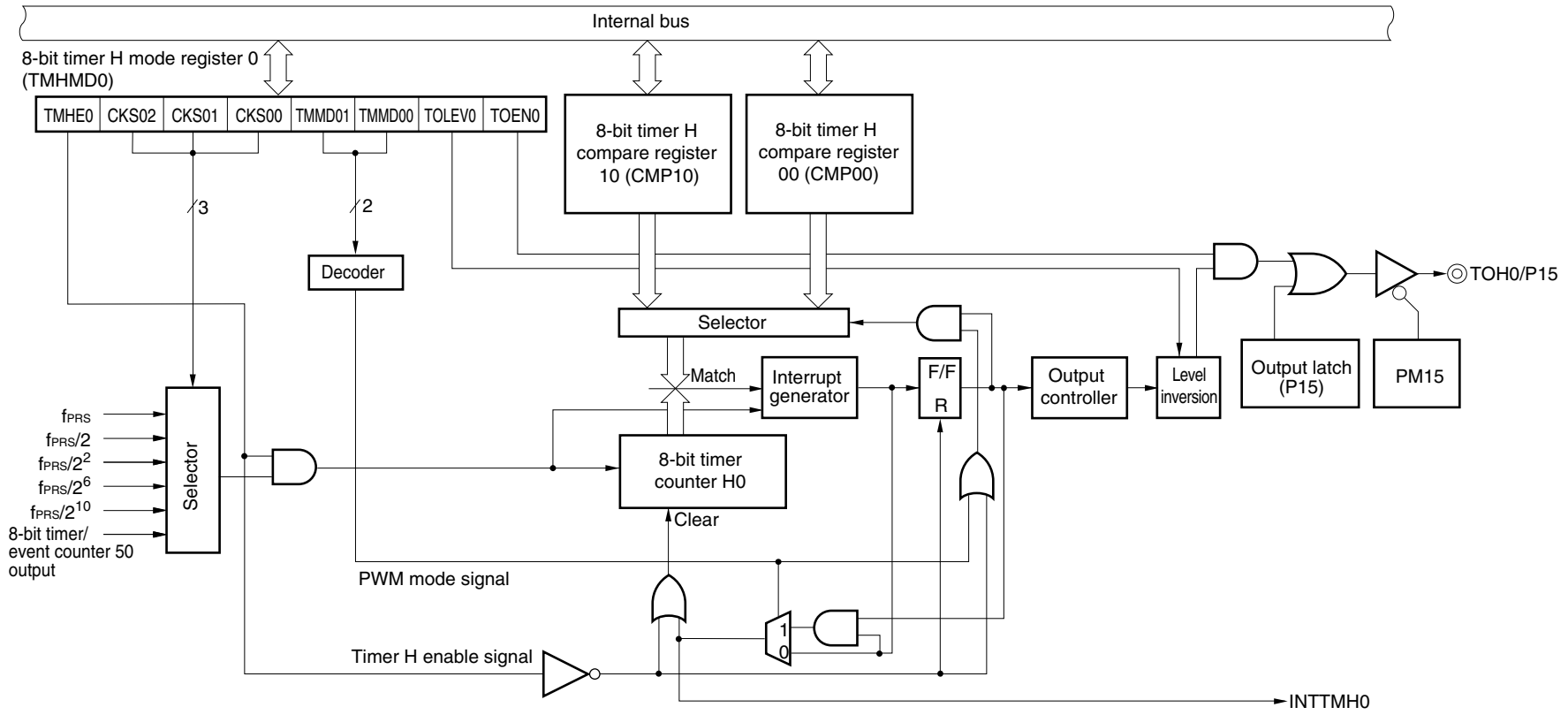

★Figure 8-2. Block Diagram of 8-Bit Timer H1

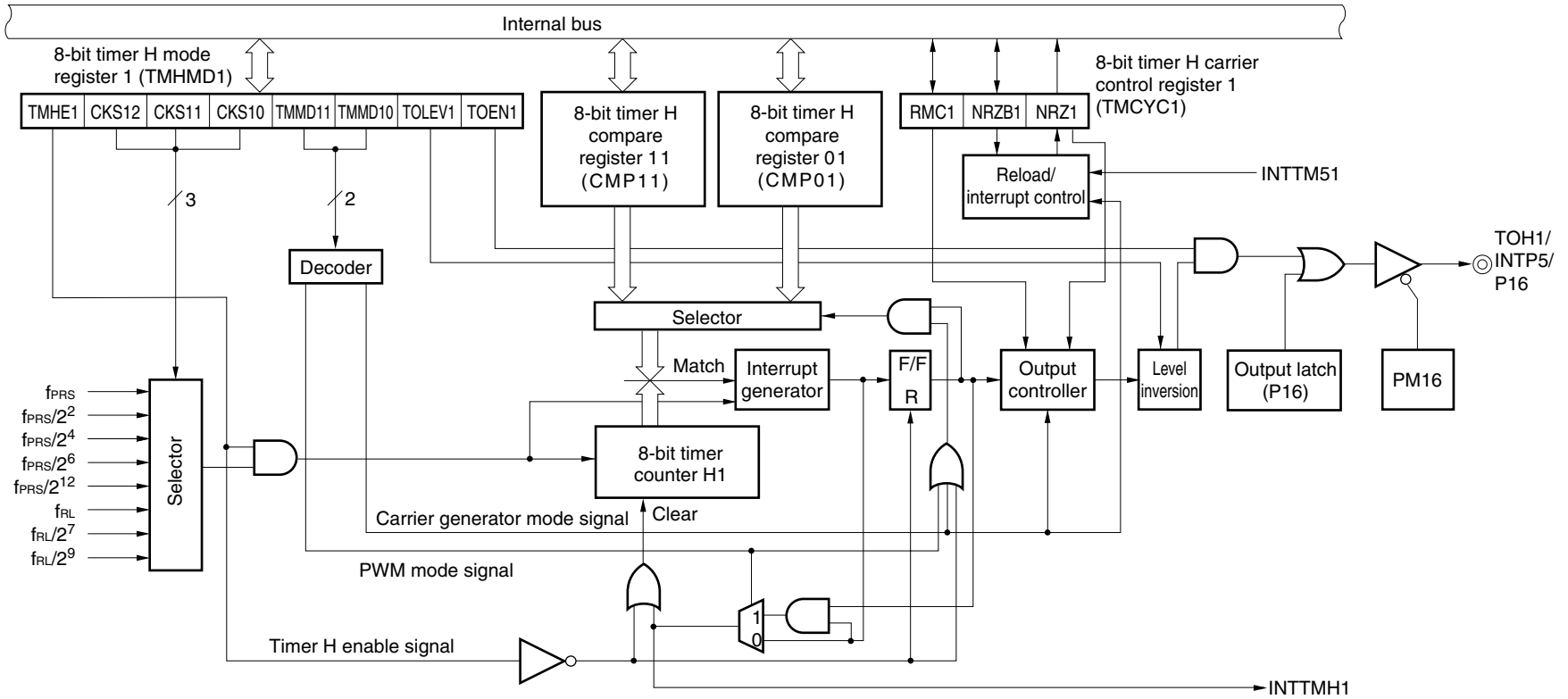

(1) 8-bit timer H compare register 0n (CMP0n)

This register can be read or written by an 8-bit memory manipulation instruction. This register is used in all of the timer operation modes.

This register constantly compares the value set to CMP0n with the count value of the 8-bit timer counter Hn and, when the two values match, generates an interrupt request signal (INTTMHn) and inverts the output level of TOHn.

Rewrite the value of CMP0n while the timer is stopped (TMHEn = 0).

A reset signal generation sets this register to 00H.

Figure 8-3. Format of 8-Bit Timer H Compare Register 0n (CMP0n)

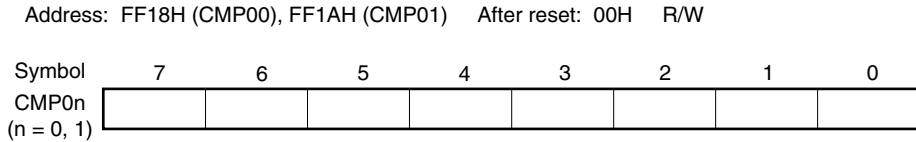

<R> **Caution** CMP0n cannot be rewritten during timer count operation. CMP0n can be refreshed (the same value is written) during timer count operation.

(2) 8-bit timer H compare register 1n (CMP1n)

This register can be read or written by an 8-bit memory manipulation instruction. This register is used in the PWM output mode and carrier generator mode.

In the PWM output mode, this register constantly compares the value set to CMP1n with the count value of the 8-bit timer counter Hn and, when the two values match, inverts the output level of TOHn. No interrupt request signal is generated.

In the carrier generator mode, the CMP1n register always compares the value set to CMP1n with the count value of the 8-bit timer counter Hn and, when the two values match, generates an interrupt request signal (INTTMHn). At the same time, the count value is cleared.

<R> CMP1n can be refreshed (the same value is written) and rewritten during timer count operation. If the value of CMP1n is rewritten while the timer is operating, the new value is latched and transferred to CMP1n when the count value of the timer matches the old value of CMP1n, and then the value of CMP1n is changed to the new value. If matching of the count value and the CMP1n value and writing a value to CMP1n conflict, the value of CMP1n is not changed.

A reset signal generation sets this register to 00H.

Figure 8-4. Format of 8-Bit Timer H Compare Register 1n (CMP1n)

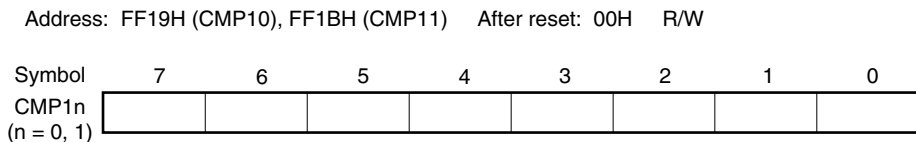

Caution In the PWM output mode and carrier generator mode, be sure to set CMP1n when starting the timer count operation (TMHEn = 1) after the timer count operation was stopped (TMHEn = 0) (be sure to set again even if setting the same value to CMP1n).

Remark n = 0, 1

8.3 Registers Controlling 8-Bit Timers H0 and H1

The following four registers are used to control 8-bit timers H0 and H1.

- 8-bit timer H mode register n (TMHMDn)
- 8-bit timer H carrier control register 1 (TMCYC1)^{Note}
- Port mode register 1 (PM1)
- Port register 1 (P1)

Note 8-bit timer H1 only

(1) 8-bit timer H mode register n (TMHMDn)

This register controls the mode of timer H.

This register can be set by a 1-bit or 8-bit memory manipulation instruction.

Reset signal generation sets this register to 00H.

Remark n = 0, 1

Figure 8-5. Format of 8-Bit Timer H Mode Register 0 (TMHMD0)

Address: FF69H After reset: 00H R/W

Symbol	<7>	6	5	4	3	2	<1>	<0>
TMHMD0	TMHE0	CKS02	CKS01	CKS00	TMMD01	TMMD00	TOLEV0	TOEN0

TMHE0	Timer operation enable
0	Stops timer count operation (counter is cleared to 0)
1	Enables timer count operation (count operation started by inputting clock)

CKS02	CKS01	CKS00		Count clock selection			
				f _{PRS} = 2 MHz	f _{PRS} = 5 MHz	f _{PRS} = 10 MHz	f _{PRS} = 20 MHz
0	0	0	f _{PRS}	2 MHz	5 MHz	10 MHz	20 MHz
0	0	1	f _{PRS} /2	1 MHz	2.5 MHz	5 MHz	10 MHz
0	1	0	f _{PRS} /2 ²	500 kHz	1.25 MHz	2.5 MHz	5 MHz
0	1	1	f _{PRS} /2 ⁶	31.25 kHz	78.13 kHz	156.25 kHz	312.5 kHz
1	0	0	f _{PRS} /2 ¹⁰	1.95 kHz	4.88 kHz	9.77 kHz	19.54 kHz
1	0	1	TM50 output ^{Note}				
Other than above			Setting prohibited				

TMMD01	TMMD00	Timer operation mode
0	0	Interval timer mode
1	0	PWM output mode
Other than above		Setting prohibited

TOLEV0	Timer output level control (in default mode)
0	Low level
1	High level

TOEN0	Timer output control
0	Disables output
1	Enables output

Note Note the following points when selecting the TM50 output as the count clock.

- Mode in which the count clock is cleared and started upon a match of TM50 and CR50 (TMC506 = 0)
Start the operation of the 8-bit timer/event counter 50 first and then enable the timer F/F inversion operation (TMC501 = 1).
- PWM mode (TMC506 = 1)
Start the operation of the 8-bit timer/event counter 50 first and then set the count clock to make the duty = 50%.

It is not necessary to enable the TO50 pin as a timer output pin in any mode.

- <R> **Cautions**
1. When $TMHE0 = 1$, setting the other bits of $TMHMD0$ is prohibited. However, $TMHMD0$ can be refreshed (the same value is written).
 2. In the PWM output mode, be sure to set the 8-bit timer H compare register 10 ($CMP10$) when starting the timer count operation ($TMHE0 = 1$) after the timer count operation was stopped ($TMHE0 = 0$) (be sure to set again even if setting the same value to $CMP10$).

- Remarks**
1. f_{PRS} : Peripheral hardware clock frequency
 2. $TMC506$: Bit 6 of 8-bit timer mode control register 50 ($TMC50$)
 $TMC501$: Bit 1 of $TMC50$

Figure 8-6. Format of 8-Bit Timer H Mode Register 1 (TMHMD1)

Address: FF6CH After reset: 00H R/W

Symbol	<7>	6	5	4	3	2	<1>	<0>
TMHMD1	TMHE1	CKS12	CKS11	CKS10	TMMD11	TMMD10	TOLEV1	TOEN1

TMHE1	Timer operation enable
0	Stops timer count operation (counter is cleared to 0)
1	Enables timer count operation (count operation started by inputting clock)

CKS12	CKS11	CKS10	Count clock selection				
			$f_{PRS} =$ 2 MHz	$f_{PRS} =$ 5 MHz	$f_{PRS} =$ 10 MHz	$f_{PRS} =$ 20 MHz	
0	0	0	f_{PRS}	2 MHz	5 MHz	10 MHz	20 MHz
0	0	1	$f_{PRS}/2^2$	500 kHz	1.25 MHz	2.5 MHz	5 MHz
0	1	0	$f_{PRS}/2^4$	125 kHz	312.5 kHz	625 kHz	1.25 MHz
0	1	1	$f_{PRS}/2^6$	31.25 kHz	78.13 kHz	156.25 kHz	312.5 kHz
1	0	0	$f_{PRS}/2^{12}$	0.49 kHz	1.22 kHz	2.44 kHz	4.88 kHz
1	0	1	$f_{RL}/2^7$	1.88 kHz (TYP.)			
1	1	0	$f_{RL}/2^9$	0.47 kHz (TYP.)			
1	1	1	f_{RL}	240 kHz (TYP.)			

TMMD11	TMMD10	Timer operation mode
0	0	Interval timer mode
0	1	Carrier generator mode
1	0	PWM output mode
1	1	Setting prohibited

TOLEV1	Timer output level control (in default mode)
0	Low level
1	High level

TOEN1	Timer output control
0	Disables output
1	Enables output

- <R> **Cautions**
1. When $TMHE1 = 1$, setting the other bits of $TMHMD1$ is prohibited. However, $TMHMD1$ can be refreshed (the same value is written).
 2. In the PWM output mode and carrier generator mode, be sure to set the 8-bit timer H compare register 11 ($CMP11$) when starting the timer count operation ($TMHE1 = 1$) after the timer count operation was stopped ($TMHE1 = 0$) (be sure to set again even if setting the same value to $CMP11$).
 3. When the carrier generator mode is used, set so that the count clock frequency of $TMH1$ becomes more than 6 times the count clock frequency of $TM51$.

- Remarks**
1. f_{PRS} : Peripheral hardware clock frequency
 2. f_{RL} : Internal low-speed oscillation clock frequency

(2) 8-bit timer H carrier control register 1 (TMCYC1)

This register controls the remote control output and carrier pulse output status of 8-bit timer H1. This register can be set by a 1-bit or 8-bit memory manipulation instruction. Reset signal generation sets this register to 00H.

Figure 8-7. Format of 8-Bit Timer H Carrier Control Register 1 (TMCYC1)

Address: FF6DH After reset: 00H R/W^{Note}

Symbol	7	6	5	4	3	2	1	<0>
TMCYC1	0	0	0	0	0	RMC1	NRZB1	NRZ1

RMC1	NRZB1	Remote control output
0	0	Low-level output
0	1	High-level output at rising edge of INTTM51 signal input
1	0	Low-level output
1	1	Carrier pulse output at rising edge of INTTM51 signal input

<R>

<R>

NRZ1	Carrier pulse output status flag
0	Carrier output disabled status (low-level status)
1	Carrier output enabled status (RMC1 = 1: Carrier pulse output, RMC1 = 0: High-level status)

Note Bit 0 is read-only.

- <R> **Caution** Do not rewrite $RMC1$ when $TMHE = 1$. However, $TMCYC1$ can be refreshed (the same value is written).

(3) Port mode register 1 (PM1)

This register sets port 1 input/output in 1-bit units.

When using the P15/TOH0 and P16/TOH1/INTP5 pins for timer output, clear PM15 and PM16 and the output latches of P15 and P16 to 0.

PM1 can be set by a 1-bit or 8-bit memory manipulation instruction.

Reset signal generation sets this register to FFH.

Figure 8-8. Format of Port Mode Register 1 (PM1)

Address: FF21H After reset: FFH R/W

Symbol	7	6	5	4	3	2	1	0
PM1	PM17	PM16	PM15	PM14	PM13	PM12	PM11	PM10

PM1n	P1n pin I/O mode selection (n = 0 to 7)
0	Output mode (output buffer on)
1	Input mode (output buffer off)

8.4 Operation of 8-Bit Timers H0 and H1

8.4.1 Operation as interval timer/square-wave output

When the 8-bit timer counter Hn and compare register 0n (CMP0n) match, an interrupt request signal (INTTMHn) is generated and the 8-bit timer counter Hn is cleared to 00H.

Compare register 1n (CMP1n) is not used in interval timer mode. Since a match of the 8-bit timer counter Hn and the CMP1n register is not detected even if the CMP1n register is set, timer output is not affected.

By setting bit 0 (TOENn) of timer H mode register n (TMHMDn) to 1, a square wave of any frequency (duty = 50%) is output from TOHn.

Setting

<1> Set each register.

Figure 8-9. Register Setting During Interval Timer/Square-Wave Output Operation

(i) Setting timer H mode register n (TMHMDn)

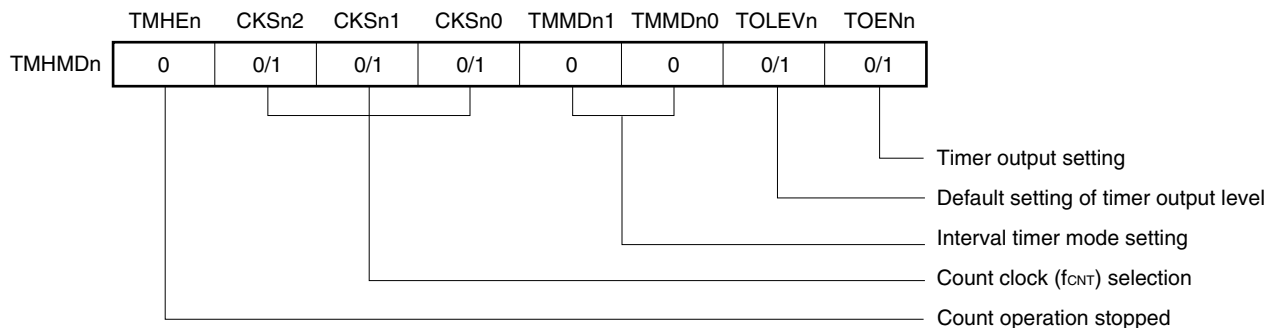

(ii) CMP0n register setting

The interval time is as follows if N is set as a comparison value.

- Interval time = $(N + 1)/f_{CNT}$

<2> Count operation starts when TMHE_n = 1.

<3> When the values of the 8-bit timer counter H_n and the CMP0n register match, the INTTMH_n signal is generated and the 8-bit timer counter H_n is cleared to 00H.

<4> Subsequently, the INTTMH_n signal is generated at the same interval. To stop the count operation, clear TMHE_n to 0.

Remarks 1. For the setting of the output pin, see **8.3 (3) Port mode register 1 (PM1)**.

2. For how to enable the INTTMH_n signal interrupt, see **CHAPTER 15 INTERRUPT FUNCTIONS**.

3. n = 0, 1

Figure 8-10. Timing of Interval Timer/Square-Wave Output Operation (1/2)

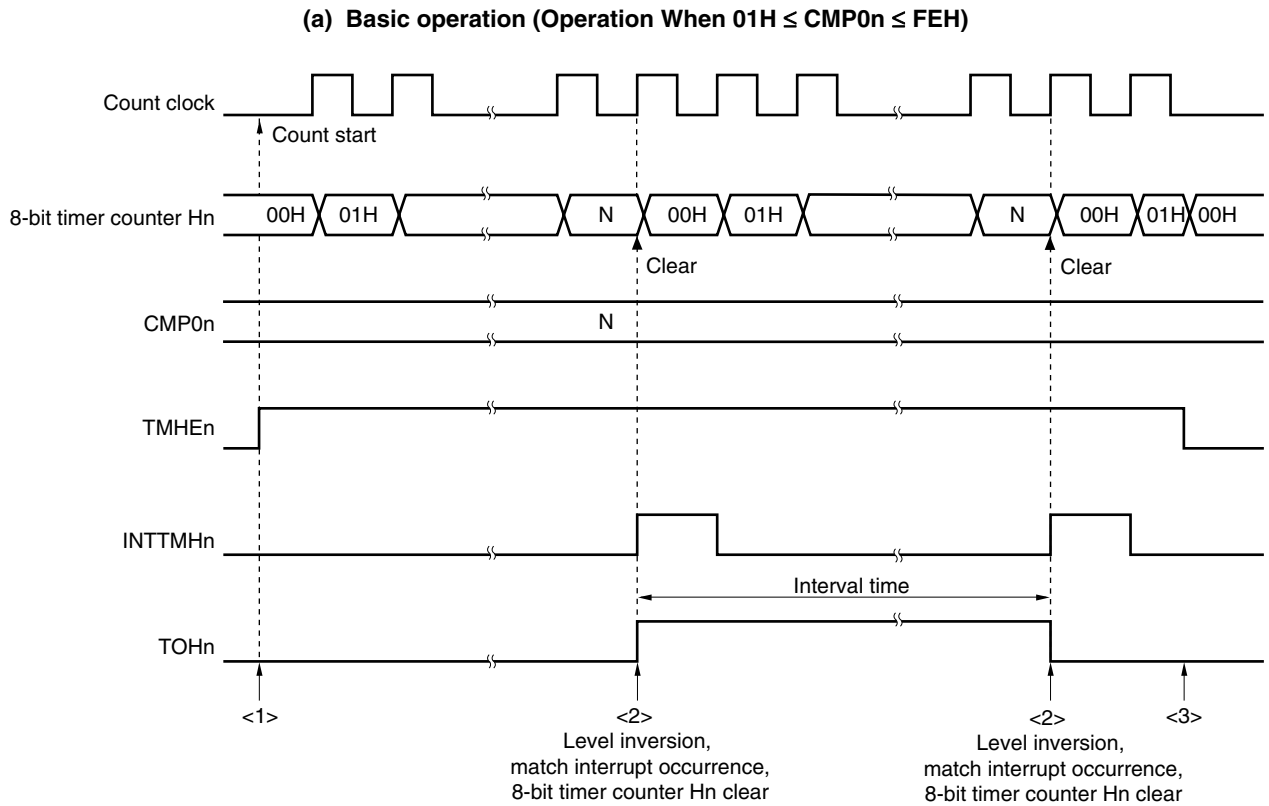

- <1> The count operation is enabled by setting the TMHEn bit to 1. The count clock starts counting no more than 1 clock after the operation is enabled.
- <2> When the value of the 8-bit timer counter Hn matches the value of the CMP0n register, the value of the timer counter is cleared, and the level of the TOHn output is inverted. In addition, the INTTMHn signal is output at the rising edge of the count clock.
- <3> If the TMHEn bit is cleared to 0 while timer H is operating, the INTTMHn signal and TOHn output are set to the default level. If they are already at the default level before the TMHEn bit is cleared to 0, then that level is maintained.

Remark $n = 0, 1$
 $01H \leq N \leq FEH$

Figure 8-10. Timing of Interval Timer/Square-Wave Output Operation (2/2)

(b) Operation when CMP0n = FFH

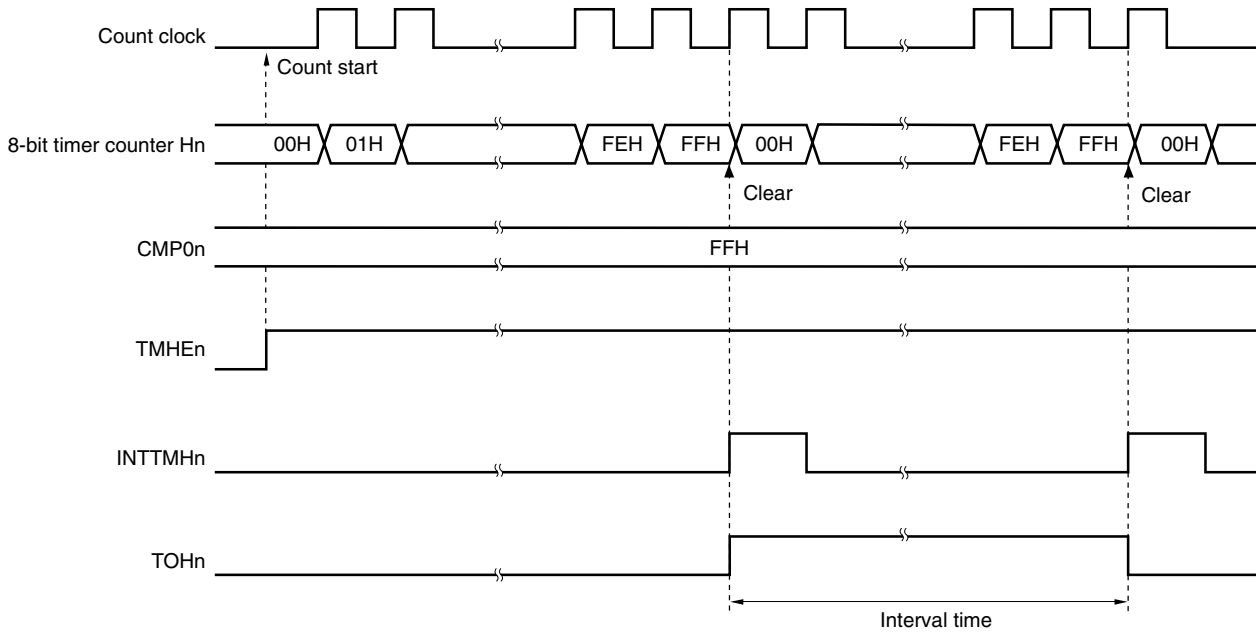

<R>

(c) Operation when CMP0n = 00H

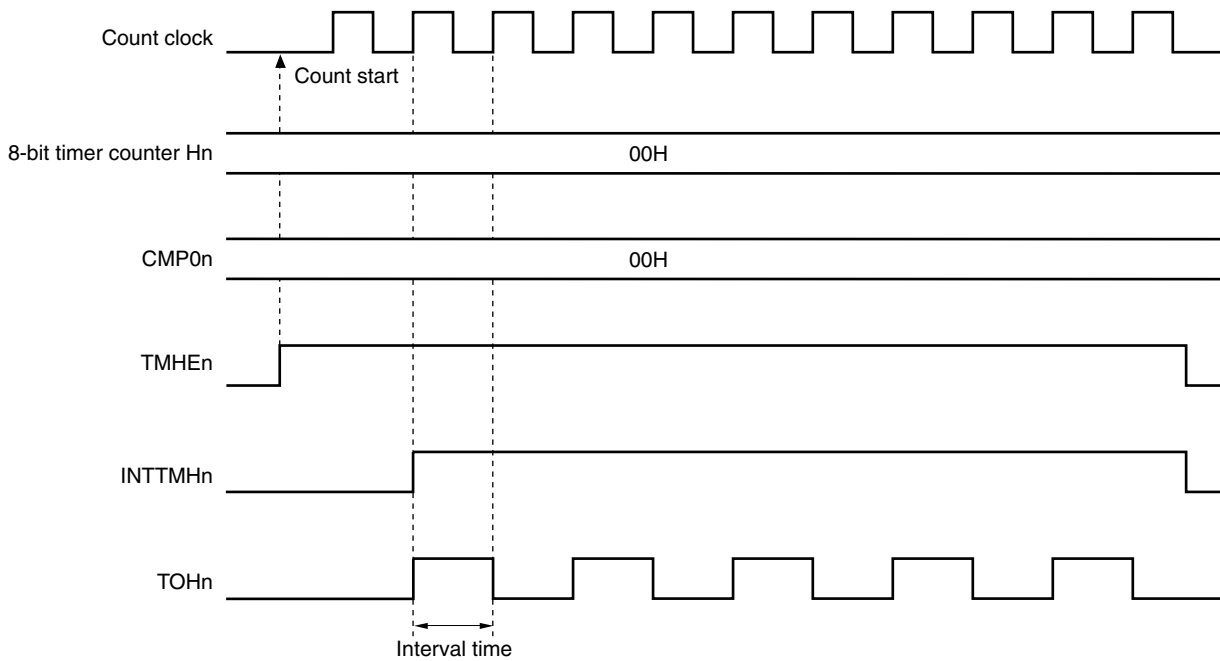

Remark n = 0, 1

8.4.2 Operation as PWM output

In PWM output mode, a pulse with an arbitrary duty and arbitrary cycle can be output.

The 8-bit timer compare register 0n (CMP0n) controls the cycle of timer output (TOHn). Rewriting the CMP0n register during timer operation is prohibited.

The 8-bit timer compare register 1n (CMP1n) controls the duty of timer output (TOHn). Rewriting the CMP1n register during timer operation is possible.

The operation in PWM output mode is as follows.

The TOHn output level is inverted and the 8-bit timer counter Hn is cleared to 0 when the 8-bit timer counter Hn and the CMP0n register match after the timer count is started. The TOHn output level is inverted when the 8-bit timer counter Hn and the CMP1n register match.

Setting

<1> Set each register.

Figure 8-11. Register Setting in PWM Output Mode

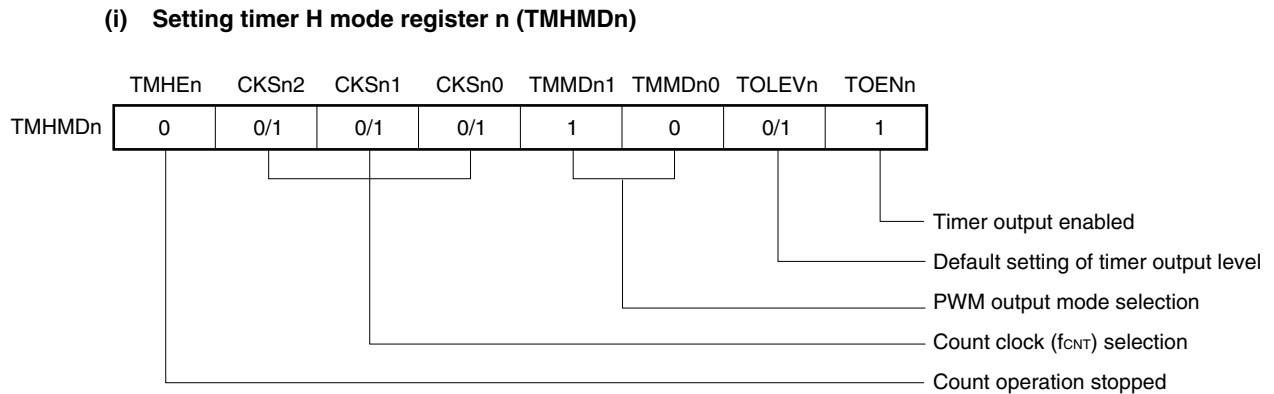

(ii) Setting CMP0n register

- Compare value (N): Cycle setting

(iii) Setting CMP1n register

- Compare value (M): Duty setting

Remarks 1. n = 0, 1

2. 00H ≤ CMP1n (M) < CMP0n (N) ≤ FFH

<2> The count operation starts when TMHEn = 1.

<3> The CMP0n register is the compare register that is to be compared first after counter operation is enabled. When the values of the 8-bit timer counter Hn and the CMP0n register match, the 8-bit timer counter Hn is cleared, an interrupt request signal (INTTMHn) is generated, and TOHn output is inverted. At the same time, the compare register to be compared with the 8-bit timer counter Hn is changed from the CMP0n register to the CMP1n register.

<4> When the 8-bit timer counter Hn and the CMP1n register match, TOHn output is inverted and the compare register to be compared with the 8-bit timer counter Hn is changed from the CMP1n register to the CMP0n register. At this time, the 8-bit timer counter Hn is not cleared and the INTTMHn signal is not generated.

- <5> By performing procedures <3> and <4> repeatedly, a pulse with an arbitrary duty can be obtained.
- <6> To stop the count operation, set $TMHE_n = 0$.

If the setting value of the $CMP0_n$ register is N , the setting value of the $CMP1_n$ register is M , and the count clock frequency is f_{CNT} , the PWM pulse output cycle and duty are as follows.

- PWM pulse output cycle = $(N + 1)/f_{CNT}$
- Duty = $(M + 1)/(N + 1)$

- Cautions**
1. The set value of the $CMP1_n$ register can be changed while the timer counter is operating. However, this takes a duration of three operating clocks (signal selected by the $CKSn_2$ to $CKSn_0$ bits of the $TMHMD_n$ register) from when the value of the $CMP1_n$ register is changed until the value is transferred to the register.
 2. Be sure to set the $CMP1_n$ register when starting the timer count operation ($TMHE_n = 1$) after the timer count operation was stopped ($TMHE_n = 0$) (be sure to set again even if setting the same value to the $CMP1_n$ register).
 3. Make sure that the $CMP1_n$ register setting value (M) and $CMP0_n$ register setting value (N) are within the following range.
 $00H \leq CMP1_n (M) < CMP0_n (N) \leq FFH$

- Remarks**
1. For the setting of the output pin, see **8.3 (3) Port mode register 1 (PM1)**.
 2. For details on how to enable the $INTTMH_n$ signal interrupt, see **CHAPTER 15 INTERRUPT FUNCTIONS**.
 3. $n = 0, 1$

Figure 8-12. Operation Timing in PWM Output Mode (1/4)

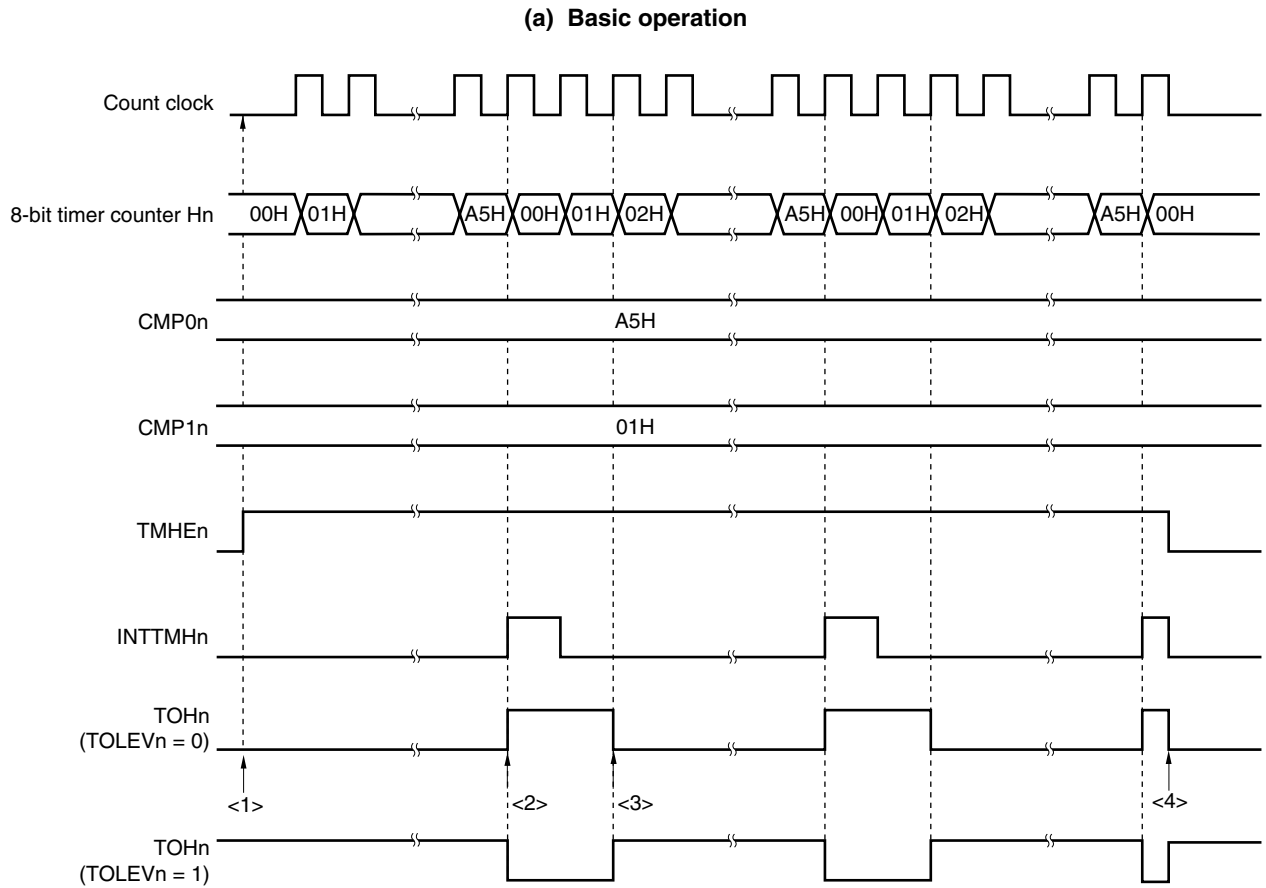

- <1> The count operation is enabled by setting the TMHEn bit to 1. Start the 8-bit timer counter Hn by masking one count clock to count up. At this time, TOHn output remains the default.
- <2> When the values of the 8-bit timer counter Hn and the CMP0n register match, the TOHn output level is inverted, the value of the 8-bit timer counter Hn is cleared, and the INTTMHn signal is output.
- <3> When the values of the 8-bit timer counter Hn and the CMP1n register match, the TOHn output level is inverted. At this time, the 8-bit timer counter value is not cleared and the INTTMHn signal is not output.
- <4> Clearing the TMHEn bit to 0 during timer Hn operation sets the INTTMHn signal and TOHn output to the default.

Remark n = 0, 1

Figure 8-12. Operation Timing in PWM Output Mode (2/4)

(b) Operation when $CMP0n = FFH$, $CMP1n = 00H$

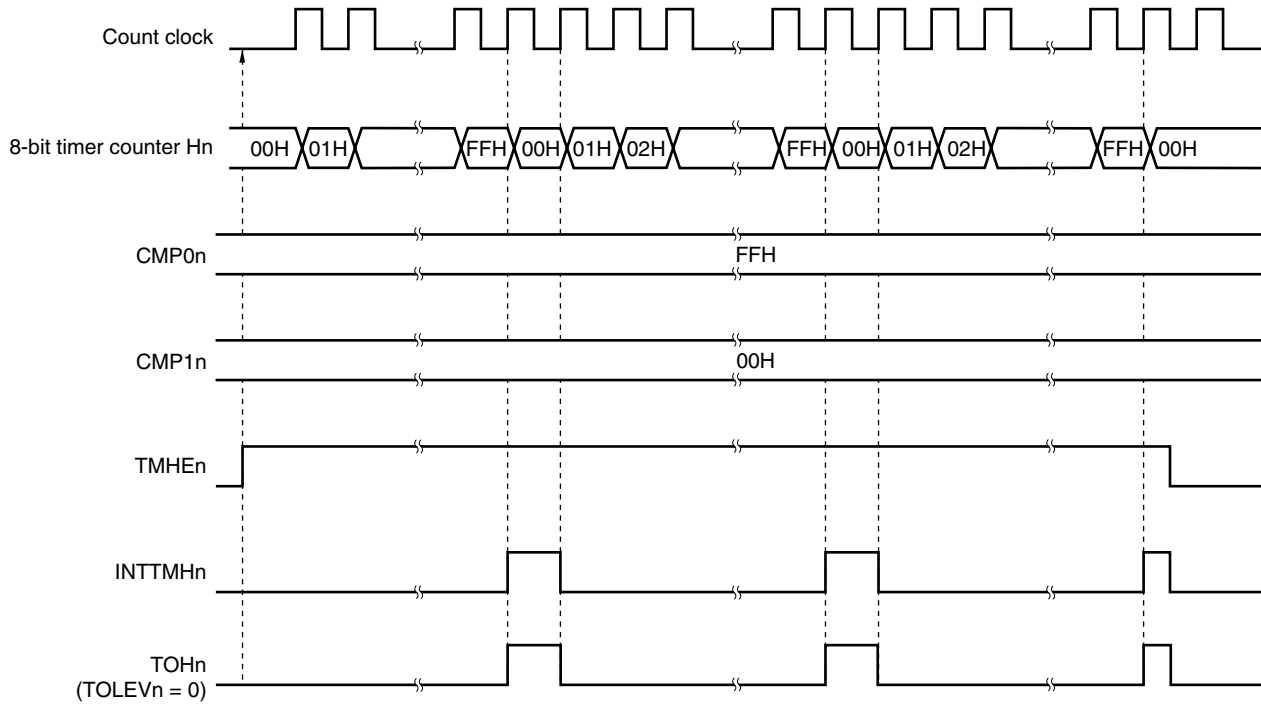

(c) Operation when $CMP0n = FFH$, $CMP1n = FEH$

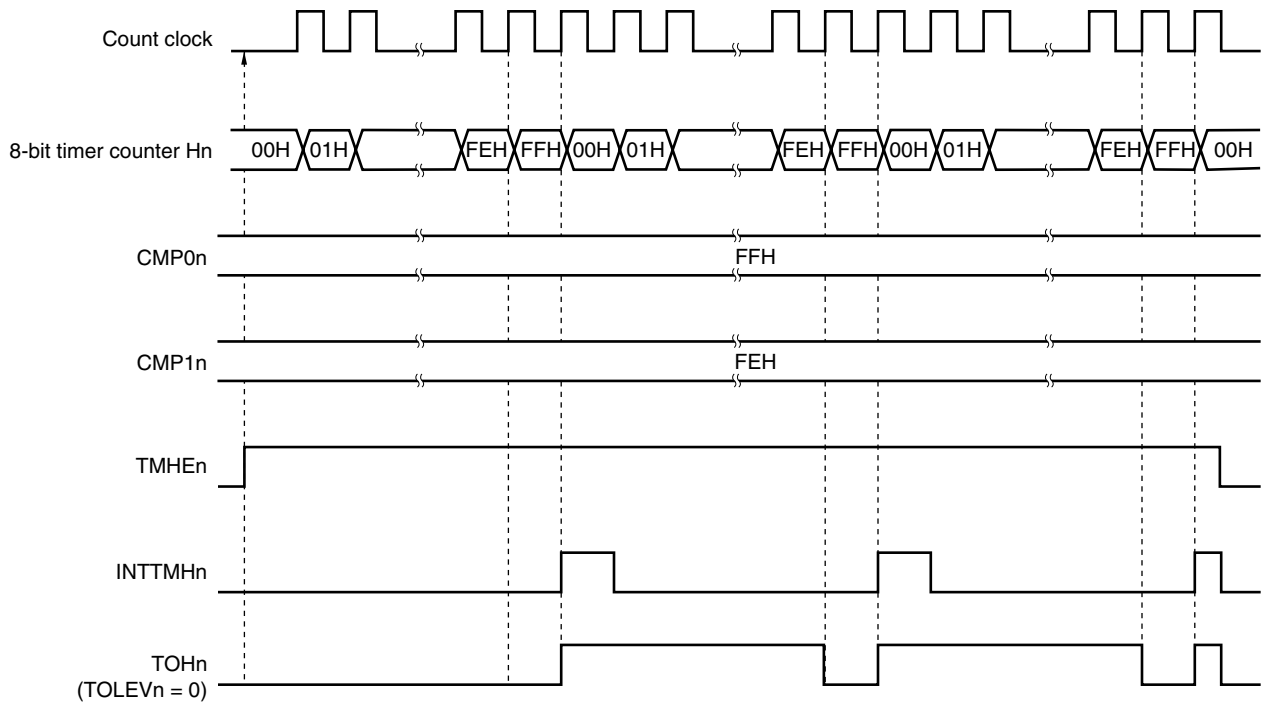

Remark n = 0, 1

Figure 8-12. Operation Timing in PWM Output Mode (3/4)

(d) Operation when $CMP0n = 01H$, $CMP1n = 00H$

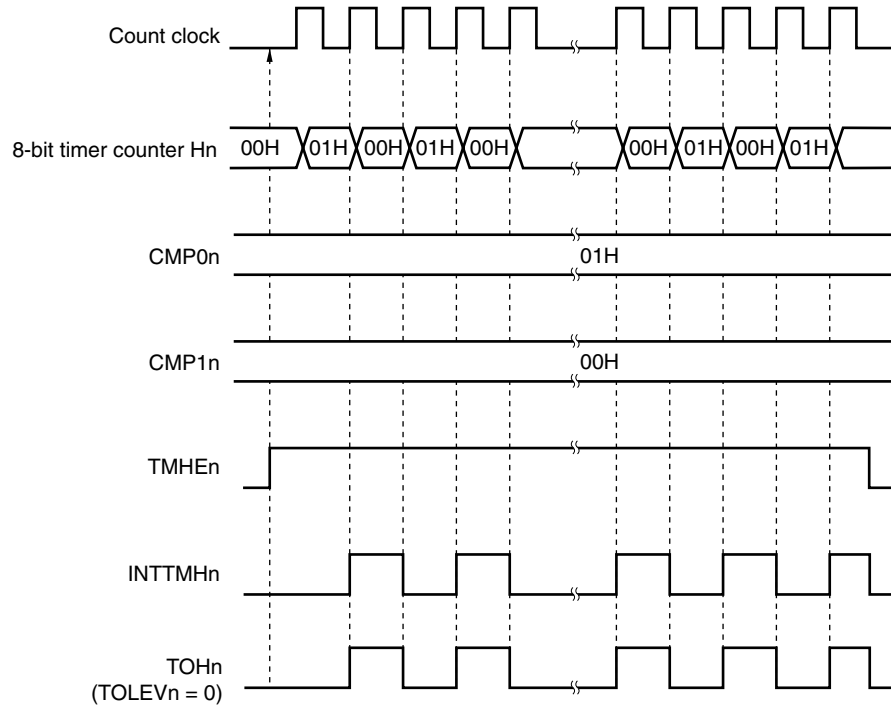

Remark n = 0, 1

Figure 8-12. Operation Timing in PWM Output Mode (4/4)

(e) Operation by changing CMP1n (CMP1n = 02H → 03H, CMP0n = A5H)

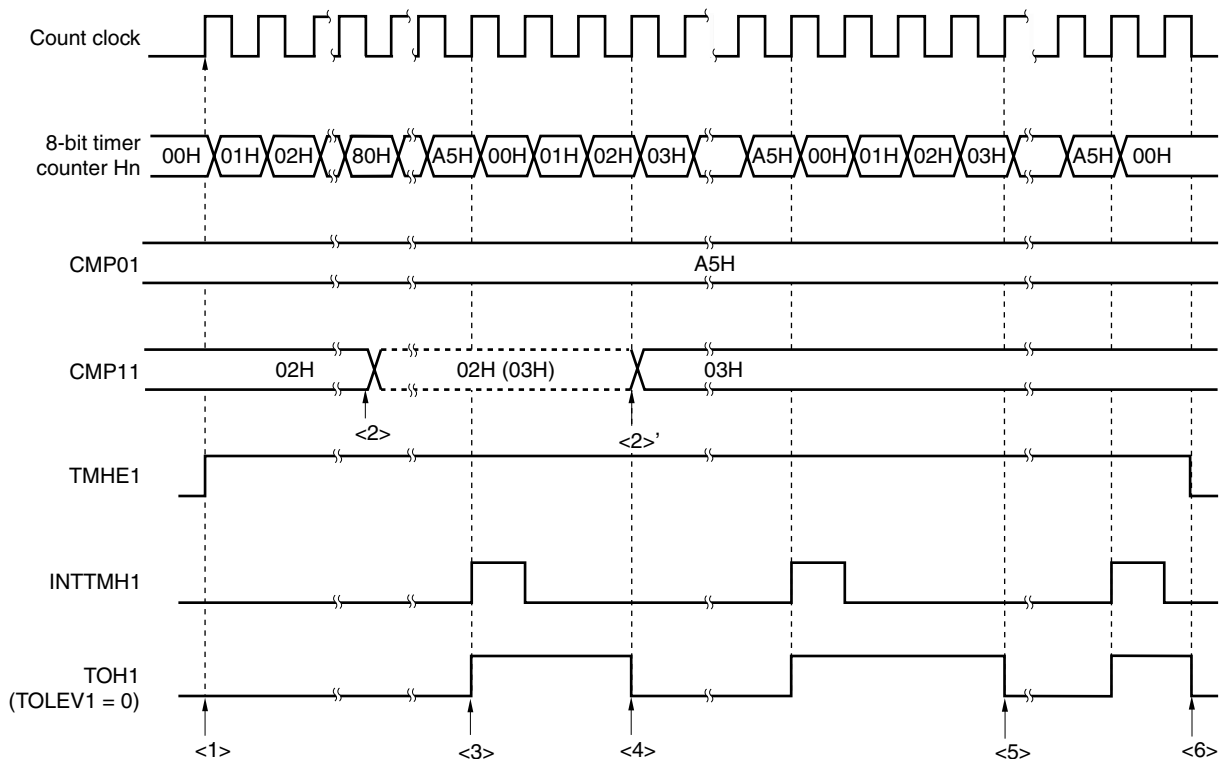

- <1> The count operation is enabled by setting TMHE_n = 1. Start the 8-bit timer counter H_n by masking one count clock to count up. At this time, the TOH_n output remains default.
- <2> The CMP1_n register value can be changed during timer counter operation. This operation is asynchronous to the count clock.
- <3> When the values of the 8-bit timer counter H_n and the CMP0_n register match, the value of the 8-bit timer counter H_n is cleared, the TOH_n output level is inverted, and the INTTMH_n signal is output.
- <4> If the CMP1_n register value is changed, the value is latched and not transferred to the register. When the values of the 8-bit timer counter H_n and the CMP1_n register before the change match, the value is transferred to the CMP1_n register and the CMP1_n register value is changed (<2>'). However, three count clocks or more are required from when the CMP1_n register value is changed to when the value is transferred to the register. If a match signal is generated within three count clocks, the changed value cannot be transferred to the register.
- <5> When the values of the 8-bit timer counter H_n and the CMP1_n register after the change match, the TOH_n output level is inverted. The 8-bit timer counter H_n is not cleared and the INTTMH_n signal is not generated.
- <6> Clearing the TMHE_n bit to 0 during timer H_n operation makes the INTTMH_n signal and TOH_n output default.

Remark n = 0, 1

8.4.3 Carrier generator operation (8-bit timer H1 only)

In the carrier generator mode, the 8-bit timer H1 is used to generate the carrier signal of an infrared remote controller, and the 8-bit timer/event counter 51 is used to generate an infrared remote control signal (time count).

The carrier clock generated by the 8-bit timer H1 is output in the cycle set by the 8-bit timer/event counter 51.

In carrier generator mode, the output of the 8-bit timer H1 carrier pulse is controlled by the 8-bit timer/event counter 51, and the carrier pulse is output from the TOH1 output.

(1) Carrier generation

In carrier generator mode, the 8-bit timer H compare register 01 (CMP01) generates a low-level width carrier pulse waveform and the 8-bit timer H compare register 11 (CMP11) generates a high-level width carrier pulse waveform.

Rewriting the CMP11 register during the 8-bit timer H1 operation is possible but rewriting the CMP01 register is prohibited.

(2) Carrier output control

Carrier output is controlled by the interrupt request signal (INTTM51) of the 8-bit timer/event counter 51 and the NRZB1 and RMC1 bits of the 8-bit timer H carrier control register (TMCYC1). The relationship between the outputs is shown below.

	RMC1 Bit	NRZB1 Bit	Output
<R>	0	0	Low-level output
	0	1	High-level output at rising edge of INTTM51 signal input
	1	0	Low-level output
<R>	1	1	Carrier pulse output at rising edge of INTTM51 signal input

To control the carrier pulse output during a count operation, the NRZ1 and NRZB1 bits of the TMCYC1 register have a master and slave bit configuration. The NRZ1 bit is read-only but the NRZB1 bit can be read and written. The INTTM51 signal is synchronized with the 8-bit timer H1 count clock and is output as the INTTM5H1 signal. The INTTM5H1 signal becomes the data transfer signal of the NRZ1 bit, and the NRZB1 bit value is transferred to the NRZ1 bit. The timing for transfer from the NRZB1 bit to the NRZ1 bit is as shown below.

Figure 8-13. Transfer Timing

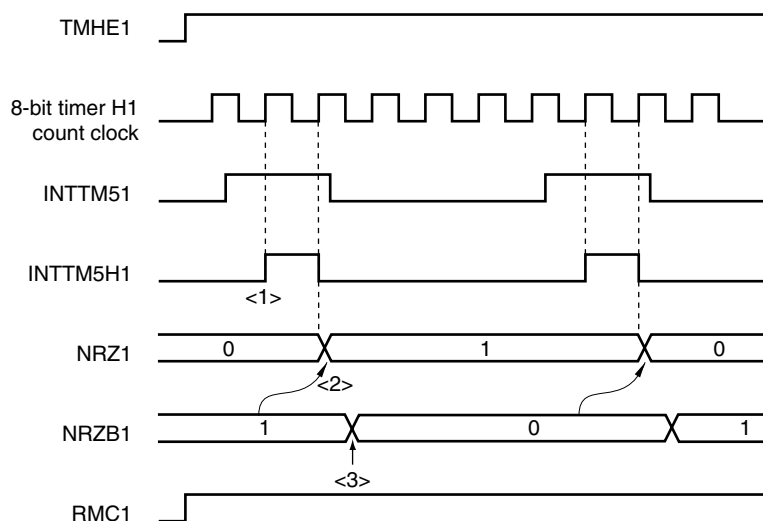

- <1> The INTTM51 signal is synchronized with the count clock of the 8-bit timer H1 and is output as the INTTM5H1 signal.
- <2> The value of the NRZB1 bit is transferred to the NRZ1 bit at the second clock from the rising edge of the INTTM5H1 signal.
- <3> Write the next value to the NRZB1 bit in the interrupt servicing program that has been started by the INTTM5H1 interrupt or after timing has been checked by polling the interrupt request flag. Write data to count the next time to the CR51 register.

- Cautions**
1. Do not rewrite the NRZB1 bit again until at least the second clock after it has been rewritten, or else the transfer from the NRZB1 bit to the NRZ1 bit is not guaranteed.
 2. When the 8-bit timer/event counter 51 is used in the carrier generator mode, an interrupt is generated at the timing of <1>. When the 8-bit timer/event counter 51 is used in a mode other than the carrier generator mode, the timing of the interrupt generation differs.

Setting

<1> Set each register.

Figure 8-14. Register Setting in Carrier Generator Mode

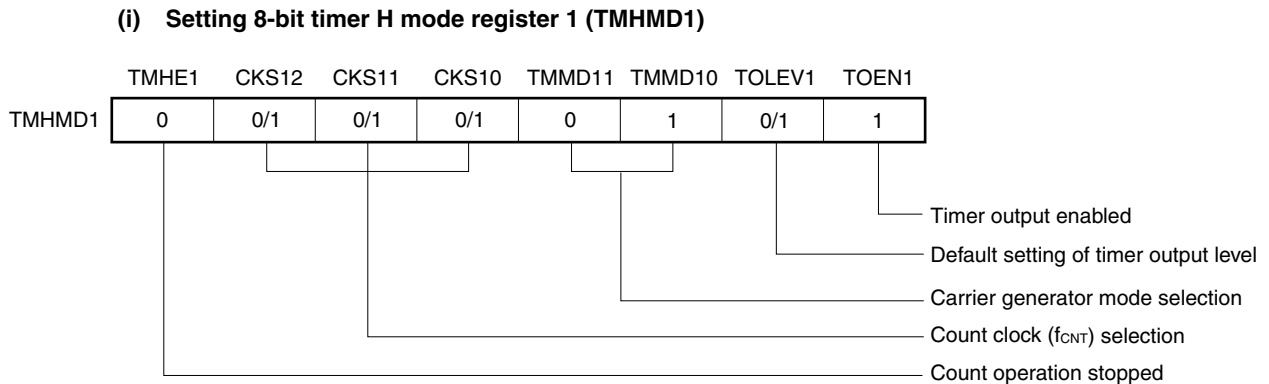

(ii) **CMP01 register setting**

- Compare value

(iii) **CMP11 register setting**

- Compare value

(iv) **TMCYC1 register setting**

- RMC1 = 1 ... Remote control output enable bit
- NRZB1 = 0/1 ... carrier output enable bit

(v) **TCL51 and TMC51 register setting**

- See 7.3 **Registers Controlling 8-Bit Timer/Event Counters 50 and 51.**

<2> When TMHE1 = 1, the 8-bit timer H1 starts counting.

<3> When TCE51 of the 8-bit timer mode control register 51 (TMC51) is set to 1, the 8-bit timer/event counter 51 starts counting.

<4> After the count operation is enabled, the first compare register to be compared is the CMP01 register. When the count value of the 8-bit timer counter H1 and the CMP01 register value match, the INTTMH1 signal is generated, the 8-bit timer counter H1 is cleared. At the same time, the compare register to be compared with the 8-bit timer counter H1 is switched from the CMP01 register to the CMP11 register.

<5> When the count value of the 8-bit timer counter H1 and the CMP11 register value match, the INTTMH1 signal is generated, the 8-bit timer counter H1 is cleared. At the same time, the compare register to be compared with the 8-bit timer counter H1 is switched from the CMP11 register to the CMP01 register.

<6> By performing procedures <4> and <5> repeatedly, a carrier clock is generated.

<7> The INTTM51 signal is synchronized with count clock of the 8-bit timer H1 and output as the INTTM5H1 signal. The INTTM5H1 signal becomes the data transfer signal for the NRZB1 bit, and the NRZB1 bit value is transferred to the NRZ1 bit.

<8> Write the next value to the NRZB1 bit in the interrupt servicing program that has been started by the INTTM5H1 interrupt or after timing has been checked by polling the interrupt request flag. Write data to count the next time to the CR51 register.

<9> When the NRZ1 bit is high level, a carrier clock is output from the TOH1 pin.

<10> By performing the procedures above, an arbitrary carrier clock is obtained. To stop the count operation, clear TMHE1 to 0.

If the setting value of the CMP01 register is N, the setting value of the CMP11 register is M, and the count clock frequency is f_{CNT} , the carrier clock output cycle and duty are as follows.

- Carrier clock output cycle = $(N + M + 2)/f_{CNT}$
- Duty = High-level width/carrier clock output width = $(M + 1)/(N + M + 2)$

- Cautions**
1. Be sure to set the CMP11 register when starting the timer count operation (TMHE1 = 1) after the timer count operation was stopped (TMHE1 = 0) (be sure to set again even if setting the same value to the CMP11 register).
 2. Set so that the count clock frequency of TMH1 becomes more than 6 times the count clock frequency of TM51.
 3. Set the values of the CMP01 and CMP11 registers in a range of 01H to FFH.
 4. The set value of the CMP11 register can be changed while the timer counter is operating. However, it takes the duration of three operating clocks (signal selected by the CKS12 to CKS10 bits of the TMHMD1 register) since the value of the CMP11 register has been changed until the value is transferred to the register.
 5. Be sure to set the RMC1 bit before the count operation is started.

- Remarks**
1. For the setting of the output pin, see 8.3 (3) Port mode register 1 (PM1).
 2. For how to enable the INTTMH1 signal interrupt, see CHAPTER 15 INTERRUPT FUNCTIONS.

Figure 8-15. Carrier Generator Mode Operation Timing (1/3)

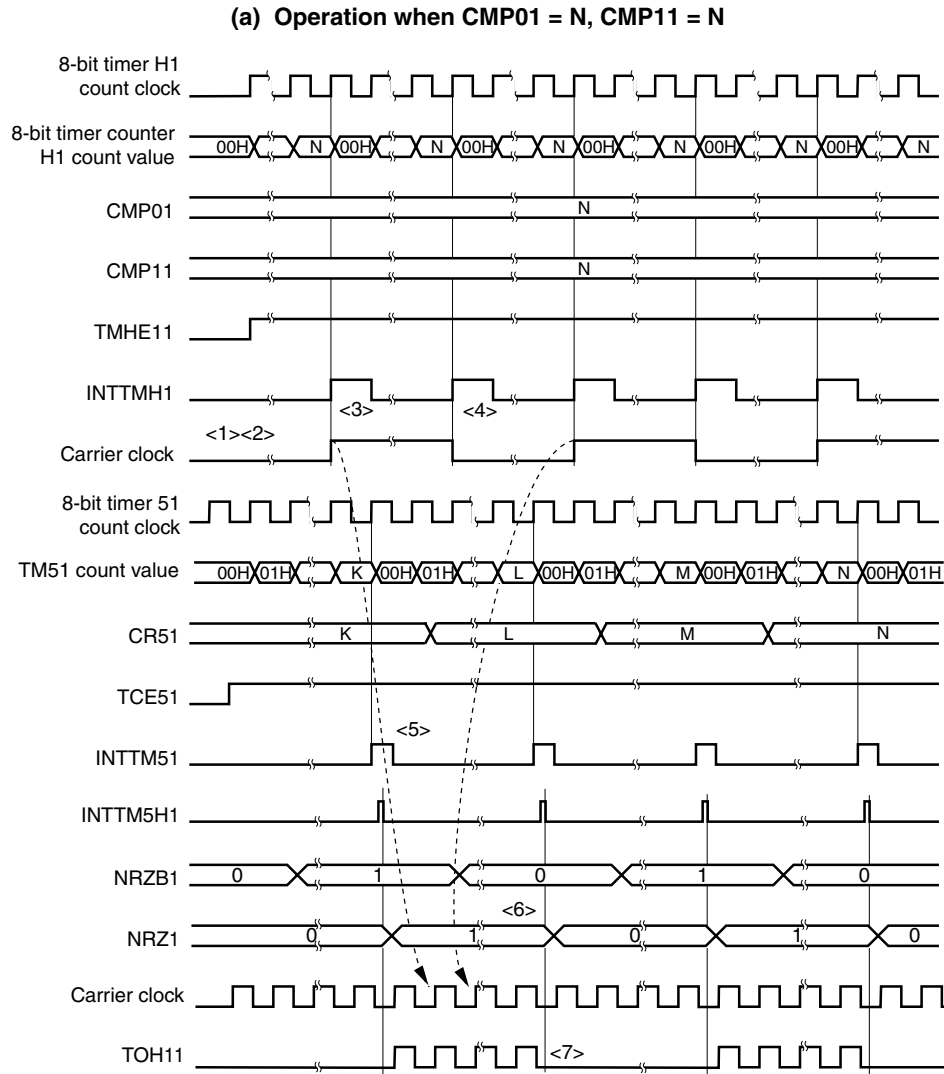

- <1> When TMHE1 = 0 and TCE51 = 0, the 8-bit timer counter H1 operation is stopped.
- <2> When TMHE1 = 1 is set, the 8-bit timer counter H1 starts a count operation. At that time, the carrier clock remains default.
- <3> When the count value of the 8-bit timer counter H1 matches the CMP01 register value, the first INTTMH1 signal is generated, the carrier clock signal is inverted, and the compare register to be compared with the 8-bit timer counter H1 is switched from the CMP01 register to the CMP11 register. The 8-bit timer counter H1 is cleared to 00H.
- <4> When the count value of the 8-bit timer counter H1 matches the CMP11 register value, the INTTMH1 signal is generated, the carrier clock signal is inverted, and the compare register to be compared with the 8-bit timer counter H1 is switched from the CMP11 register to the CMP01 register. The 8-bit timer counter H1 is cleared to 00H. By performing procedures <3> and <4> repeatedly, a carrier clock with duty fixed to 50% is generated.
- <5> When the INTTM51 signal is generated, it is synchronized with the 8-bit timer H1 count clock and is output as the INTTM5H1 signal.
- <6> The INTTM5H1 signal becomes the data transfer signal for the NRZB1 bit, and the NRZB1 bit value is transferred to the NRZ1 bit.
- <7> When NRZ1 = 0 is set, the TOH1 output becomes low level.

Figure 8-15. Carrier Generator Mode Operation Timing (2/3)

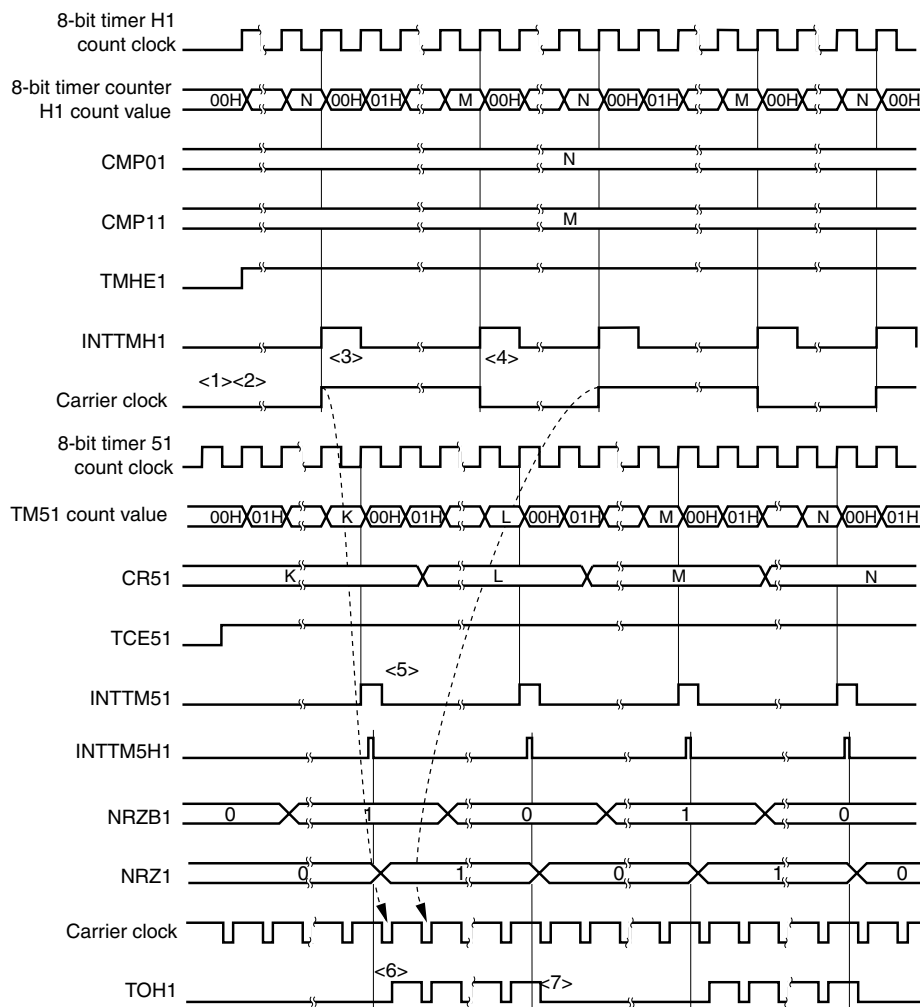
(b) Operation when $CMP01 = N$, $CMP11 = M$ 

- <1> When $TMHE1 = 0$ and $TCE51 = 0$, the 8-bit timer counter H1 operation is stopped.
- <2> When $TMHE1 = 1$ is set, the 8-bit timer counter H1 starts a count operation. At that time, the carrier clock remains default.
- <3> When the count value of the 8-bit timer counter H1 matches the $CMP01$ register value, the first $INTTMH1$ signal is generated, the carrier clock signal is inverted, and the compare register to be compared with the 8-bit timer counter H1 is switched from the $CMP01$ register to the $CMP11$ register. The 8-bit timer counter H1 is cleared to $00H$.
- <4> When the count value of the 8-bit timer counter H1 matches the $CMP11$ register value, the $INTTMH1$ signal is generated, the carrier clock signal is inverted, and the compare register to be compared with the 8-bit timer counter H1 is switched from the $CMP11$ register to the $CMP01$ register. The 8-bit timer counter H1 is cleared to $00H$. By performing procedures <3> and <4> repeatedly, a carrier clock with duty fixed to other than 50% is generated.
- <5> When the $INTTM51$ signal is generated, it is synchronized with the 8-bit timer H1 count clock and is output as the $INTTM5H1$ signal.
- <6> A carrier signal is output at the first rising edge of the carrier clock if $NRZ1$ is set to 1.
- <7> When $NRZ1 = 0$, the $TOH1$ output is held at the high level and is not changed to low level while the carrier clock is high level (from <6> and <7>, the high-level width of the carrier clock waveform is guaranteed).

Figure 8-15. Carrier Generator Mode Operation Timing (3/3)

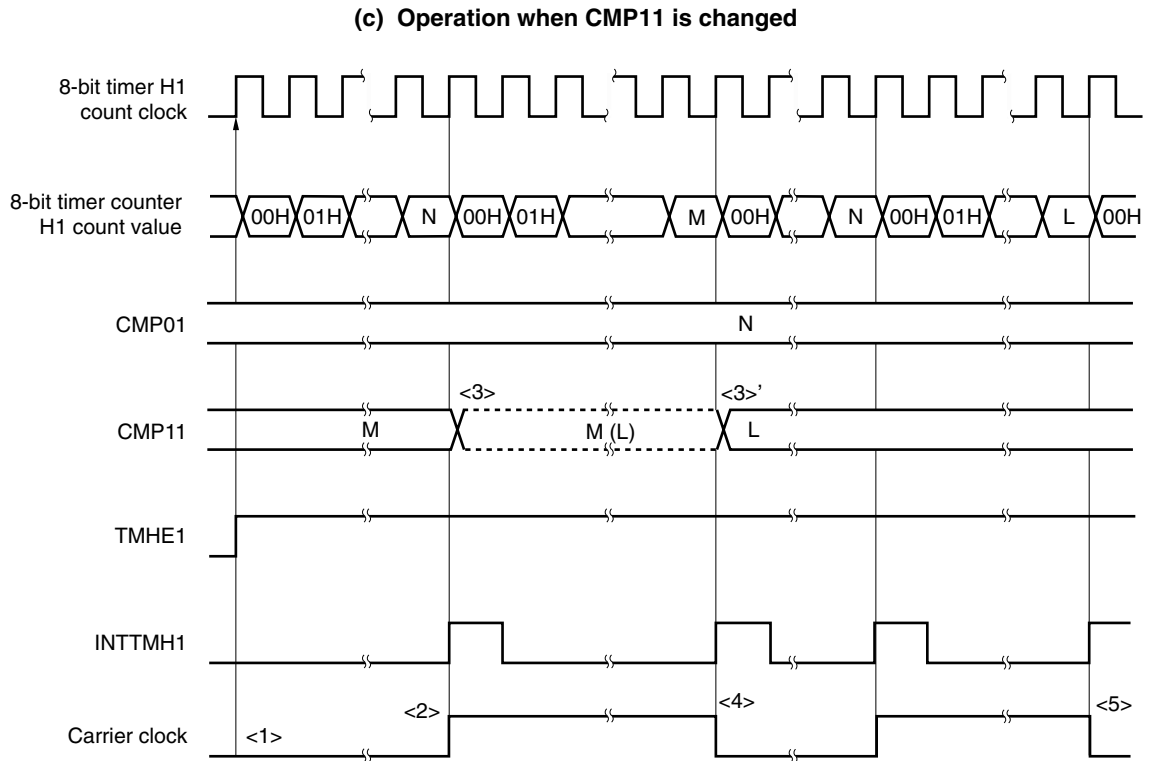

- <1> When TMHE1 = 1 is set, the 8-bit timer H1 starts a count operation. At that time, the carrier clock remains default.
- <2> When the count value of the 8-bit timer counter H1 matches the value of the CMP01 register, the INTTMH1 signal is output, the carrier signal is inverted, and the timer counter is cleared to 00H. At the same time, the compare register whose value is to be compared with that of the 8-bit timer counter H1 is changed from the CMP01 register to the CMP11 register.
- <3> The CMP11 register is asynchronous to the count clock, and its value can be changed while the 8-bit timer H1 is operating. The new value (L) to which the value of the register is to be changed is latched. When the count value of the 8-bit timer counter H1 matches the value (M) of the CMP11 register before the change, the CMP11 register is changed (<3>'). However, it takes three count clocks or more since the value of the CMP11 register has been changed until the value is transferred to the register. Even if a match signal is generated before the duration of three count clocks elapses, the new value is not transferred to the register.
- <4> When the count value of 8-bit timer counter H1 matches the value (M) of the CMP1 register before the change, the INTTMH1 signal is output, the carrier signal is inverted, and the timer counter is cleared to 00H. At the same time, the compare register whose value is to be compared with that of the 8-bit timer counter H1 is changed from the CMP11 register to the CMP01 register.
- <5> The timing at which the count value of the 8-bit timer counter H1 and the CMP11 register value match again is indicated by the value after the change (L).

CHAPTER 9 WATCHDOG TIMER

9.1 Functions of Watchdog Timer

The watchdog timer operates on the internal low-speed oscillation clock.

The watchdog timer is used to detect an inadvertent program loop. If a program loop is detected, an internal reset signal is generated.

Program loop is detected in the following cases.

- If the watchdog timer counter overflows
- If a 1-bit manipulation instruction is executed on the watchdog timer enable register (WDTE)
- If data other than “ACH” is written to WDTE
- If data is written to WDTE during a window close period
- If the instruction is fetched from an area not set by the IMS register (detection of an invalid check while the CPU hangs up)
- If the CPU accesses an area that is not set by the IMS register (excluding FB00H to FFFFH) by executing a read/write instruction (detection of an abnormal access during a CPU program loop)

When a reset occurs due to the watchdog timer, bit 4 (WDTRF) of the reset control flag register (RESF) is set to 1. For details of RESF, see **CHAPTER 17 RESET FUNCTION**.

9.2 Configuration of Watchdog Timer

The watchdog timer includes the following hardware.

Table 9-1. Configuration of Watchdog Timer

Item	Configuration
Control register	Watchdog timer enable register (WDTE)

How the counter operation is controlled, overflow time, and window open period are set by the option byte.

Table 9-2. Setting of Option Bytes and Watchdog Timer

Setting of Watchdog Timer	Option Byte (0080H)
Window open period	Bits 6 and 5 (WINDOW1, WINDOW0)
Controlling counter operation of watchdog timer	Bit 4 (WDTON)
Overflow time of watchdog timer	Bits 3 to 1 (WDCS2 to WDCS0)

Remark For the option byte, see **CHAPTER 20 OPTION BYTE**.

Figure 9-1. Block Diagram of Watchdog Timer

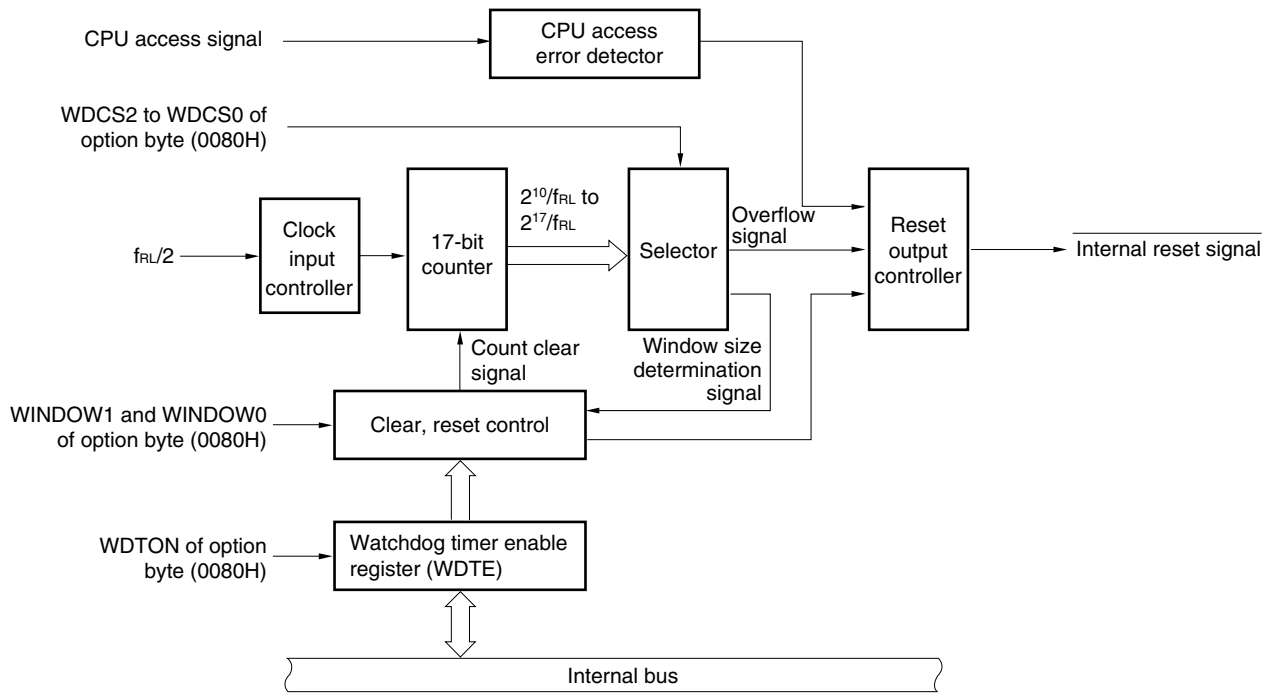

9.3 Register Controlling Watchdog Timer

The watchdog timer is controlled by the watchdog timer enable register (WDTE).

(1) Watchdog timer enable register (WDTE)

Writing ACH to WDTE clears the watchdog timer counter and starts counting again.

This register can be set by an 8-bit memory manipulation instruction.

Reset signal generation sets this register to 9AH or 1AH^{Note}.

Figure 9-2. Format of Watchdog Timer Enable Register (WDTE)

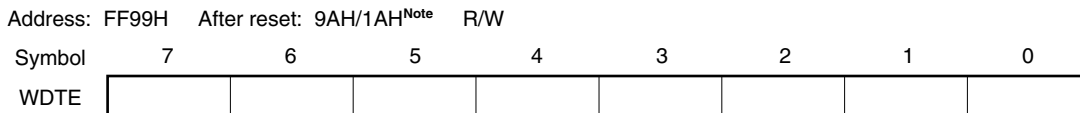

Note The WDTE reset value differs depending on the WDTON setting value of the option byte (0080H). To operate watchdog timer, set WDTON to 1.

WDTON Setting Value	WDTE Reset Value
0 (watchdog timer count operation disabled)	1AH
1 (watchdog timer count operation enabled)	9AH

- Cautions**
1. If a value other than ACH is written to WDTE, an internal reset signal is generated. If the source clock to the watchdog timer is stopped, however, an internal reset signal is generated when the source clock to the watchdog timer resumes operation.
 2. If a 1-bit memory manipulation instruction is executed for WDTE, an internal reset signal is generated. If the source clock to the watchdog timer is stopped, however, an internal reset signal is generated when the source clock to the watchdog timer resumes operation.
 3. The value read from WDTE is 9AH/1AH (this differs from the written value (ACH)).

9.4 Operation of Watchdog Timer

9.4.1 Controlling operation of watchdog timer

1. When the watchdog timer is used, its operation is specified by the option byte (0080H).
 - Enable counting operation of the watchdog timer by setting bit 4 (WDTON) of the option byte (0080H) to 1 (the counter starts operating after a reset release) (for details, see **CHAPTER 20**).

WDTON	Operation Control of Watchdog Timer Counter/Illegal Access Detection
0	Counter operation disabled (counting stopped after reset), illegal access detection operation disabled
1	Counter operation enabled (counting started after reset), illegal access detection operation enabled

- Set an overflow time by using bits 3 to 1 (WDCS2 to WDCS0) of the option byte (0080H) (for details, see **9.4.2** and **CHAPTER 20**).
 - Set a window open period by using bits 6 and 5 (WINDOW1 and WINDOW0) of the option byte (0080H) (for details, see **9.4.3** and **CHAPTER 20**).
2. After a reset release, the watchdog timer starts counting.
 3. By writing “ACH” to WDTE after the watchdog timer starts counting and before the overflow time set by the option byte, the watchdog timer is cleared and starts counting again.
 4. After that, write WDTE the second time or later after a reset release during the window open period. If WDTE is written during a window close period, an internal reset signal is generated.
 5. If the overflow time expires without “ACH” written to WDTE, an internal reset signal is generated. An internal reset signal is generated in the following cases.
 - If a 1-bit manipulation instruction is executed on the watchdog timer enable register (WDTE)
 - If data other than “ACH” is written to WDTE
 - If the instruction is fetched from an area not set by the IMS register (detection of an invalid check during a CPU program loop)
 - If the CPU accesses an area not set by the IMS register (excluding FB00H to FFFFH) by executing a read/write instruction (detection of an abnormal access during a CPU program loop)

- Cautions**
1. **The first writing to WDTE after a reset release clears the watchdog timer, if it is made before the overflow time regardless of the timing of the writing, and the watchdog timer starts counting again.**
 2. **If the watchdog timer is cleared by writing “ACH” to WDTE, the actual overflow time may be different from the overflow time set by the option byte by up to $2/f_{RL}$ seconds.**
 3. **The watchdog timer can be cleared immediately before the count value overflows (FFFFH).**

Cautions 4. The operation of the watchdog timer in the HALT and STOP modes differs as follows depending on the set value of bit 0 (LSROSC) of the option byte.

	LSROSC = 0 (Internal Low-Speed Oscillator Can Be Stopped by Software)	LSROSC = 1 (Internal Low-Speed Oscillator Cannot Be Stopped)
In HALT mode	Watchdog timer operation stops.	Watchdog timer operation continues.
In STOP mode		

If LSROSC = 0, the watchdog timer resumes counting after the HALT or STOP mode is released. At this time, the counter is not cleared to 0 but starts counting from the value at which it was stopped.

If oscillation of the internal low-speed oscillator is stopped by setting LSRSTOP (bit 1 of the internal oscillation mode register (RCM) = 1) when LSROSC = 0, the watchdog timer stops operating. At this time, the counter is not cleared to 0.

5. The watchdog timer continues its operation during self-programming and EEPROM™ emulation of the flash memory. During processing, the interrupt acknowledge time is delayed. Set the overflow time and window size taking this delay into consideration.

9.4.2 Setting overflow time of watchdog timer

Set the overflow time of the watchdog timer by using bits 3 to 1 (WDCS2 to WDCS0) of the option byte (0080H).

If an overflow occurs, an internal reset signal is generated. The present count is cleared and the watchdog timer starts counting again by writing “ACH” to WDTE during the window open period before the overflow time.

The following overflow time is set.

Table 9-3. Setting of Overflow Time of Watchdog Timer

WDCS2	WDCS1	WDCS0	Overflow Time of Watchdog Timer
0	0	0	$2^{10}/f_{RL}$ (3.88 ms)
0	0	1	$2^{11}/f_{RL}$ (7.76 ms)
0	1	0	$2^{12}/f_{RL}$ (15.52 ms)
0	1	1	$2^{13}/f_{RL}$ (31.03 ms)
1	0	0	$2^{14}/f_{RL}$ (62.06 ms)
1	0	1	$2^{15}/f_{RL}$ (124.12 ms)
1	1	0	$2^{16}/f_{RL}$ (248.24 ms)
1	1	1	$2^{17}/f_{RL}$ (496.48 ms)

Cautions 1. The combination of WDCS2 = WDCS1 = WDCS0 = 0 and WINDOW1 = WINDOW0 = 0 is prohibited.

2. The watchdog timer continues its operation during self-programming and EEPROM emulation of the flash memory. During processing, the interrupt acknowledge time is delayed. Set the overflow time and window size taking this delay into consideration.

Remarks 1. f_{RL} : Internal low-speed oscillation clock frequency
 2. (): $f_{RL} = 264$ kHz (MAX.)

9.4.3 Setting window open period of watchdog timer

Set the window open period of the watchdog timer by using bits 6 and 5 (WINDOW1, WINDOW0) of the option byte (0080H). The outline of the window is as follows.

- If “ACH” is written to WDTE during the window open period, the watchdog timer is cleared and starts counting again.
- Even if “ACH” is written to WDTE during the window close period, an abnormality is detected and an internal reset signal is generated.

Example: If the window open period is 25%

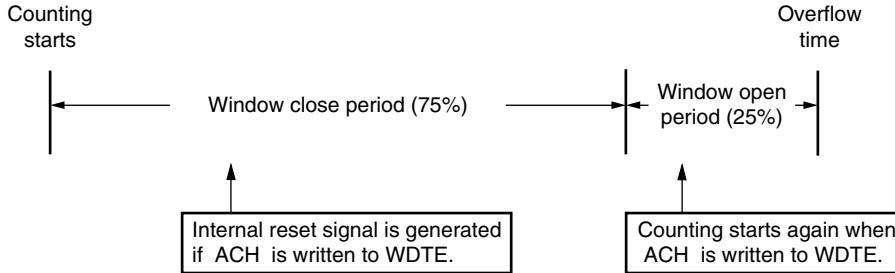

Caution The first writing to WDTE after a reset release clears the watchdog timer, if it is made before the overflow time regardless of the timing of the writing, and the watchdog timer starts counting again.

The window open period to be set is as follows.

Table 9-4. Setting Window Open Period of Watchdog Timer

WINDOW1	WINDOW0	Window Open Period of Watchdog Timer
0	0	25%
0	1	50%
1	0	75%
1	1	100%

- Cautions**
1. The combination of WDCS2 = WDCS1 = WDCS0 = 0 and WINDOW1 = WINDOW0 = 0 is prohibited.
 2. The watchdog timer continues its operation during self-programming and EEPROM emulation of the flash memory. During processing, the interrupt acknowledge time is delayed. Set the overflow time and window size taking this delay into consideration.

Remark If the overflow time is set to $2^{10}/f_{RL}$, the window close time and open time are as follows.

	Setting of Window Open Period			
	25%	50%	75%	100%
Window close time	0 to 3.56 ms	0 to 2.37 ms	0 to 0.119 ms	None
Window open time	3.56 to 3.88 ms	2.37 to 3.88 ms	0.119 to 3.88 ms	0 to 3.88 ms

<When window open period is 25%>

- Overflow time:
 $2^{10}/f_{RL} \text{ (MAX.)} = 2^{10}/264 \text{ kHz (MAX.)} = 3.88 \text{ ms}$
- Window close time:
 $0 \text{ to } 2^{10}/f_{RL} \text{ (MIN.)} \times (1 - 0.25) = 0 \text{ to } 2^{10}/216 \text{ kHz (MIN.)} \times 0.75 = 0 \text{ to } 3.56 \text{ ms}$
- Window open time:
 $2^{10}/f_{RL} \text{ (MIN.)} \times (1 - 0.25) \text{ to } 2^{10}/f_{RL} \text{ (MAX.)} = 2^{10}/216 \text{ kHz (MIN.)} \times 0.75 \text{ to } 2^{10}/264 \text{ kHz (MAX.)}$
 $= 3.56 \text{ to } 3.88 \text{ ms}$

CHAPTER 10 A/D CONVERTER

10.1 Function of A/D Converter

The A/D converter converts an analog input signal into a digital value, and consists of up to eight channels (ANI0 to ANI3) with a resolution of 10 bits.

The A/D converter has the following function.

- **10-bit resolution A/D conversion**

10-bit resolution A/D conversion is carried out repeatedly for one analog input channel selected from ANI0 to ANI3. Each time an A/D conversion operation ends, an interrupt request (INTAD) is generated.

Figure 10-1. Block Diagram of A/D Converter

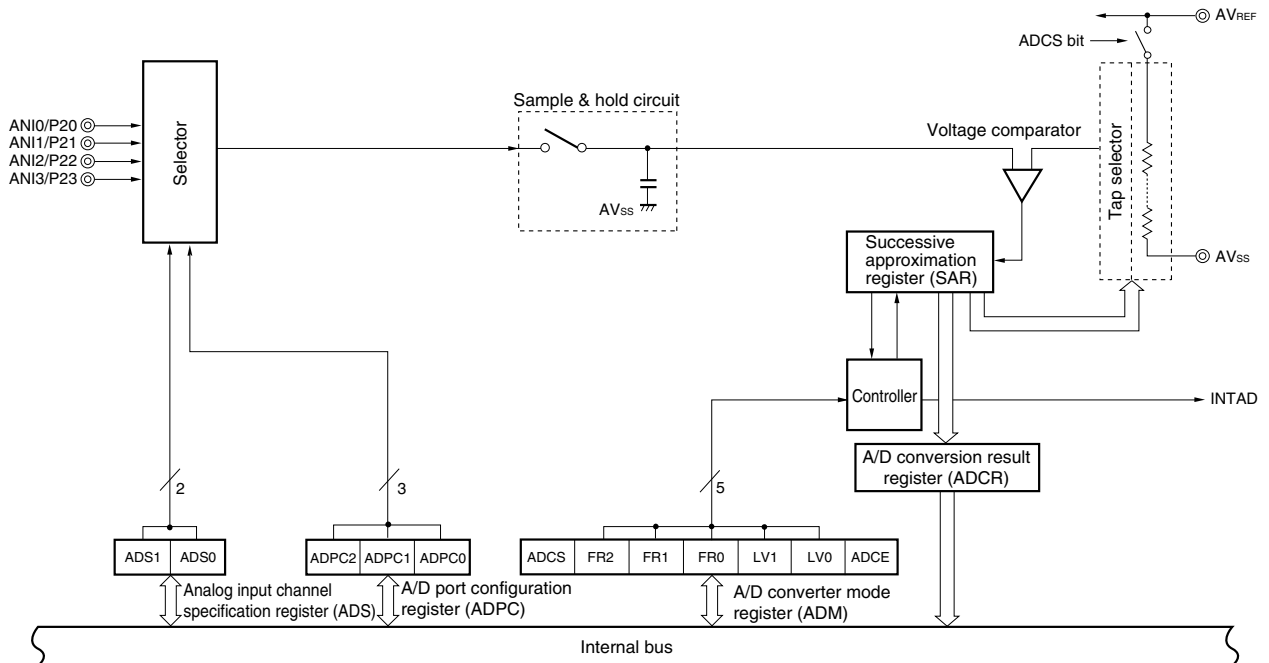

10.2 Configuration of A/D Converter

The A/D converter includes the following hardware.

(1) ANI0 to ANI3 pins

These are the analog input pins of the 3-channel A/D converter. They input analog signals to be converted into digital signals. Pins other than the one selected as the analog input pin can be used as I/O port pins.

(2) Sample & hold circuit

The sample & hold circuit samples the input voltage of the analog input pin selected by the selector when A/D conversion is started, and holds the sampled voltage value during A/D conversion.

(3) Series resistor string

The series resistor string is connected between AV_{REF} and AV_{SS} , and generates a voltage to be compared with the sampled voltage value.

Figure 10-2. Circuit Configuration of Series Resistor String

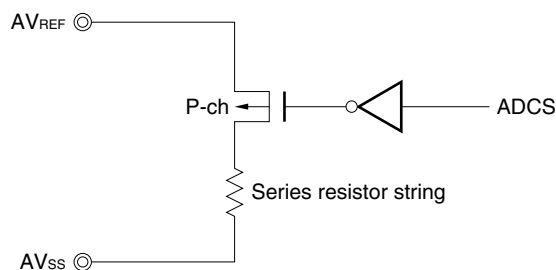

(4) Voltage comparator

The voltage comparator compares the sampled voltage value and the output voltage of the series resistor string.

(5) Successive approximation register (SAR)

This register converts the result of comparison by the voltage comparator, starting from the most significant bit (MSB).

When the voltage value is converted into a digital value down to the least significant bit (LSB) (end of A/D conversion), the contents of the SAR register are transferred to the A/D conversion result register (ADCR).

(6) 10-bit A/D conversion result register (ADCR)

The A/D conversion result is loaded from the successive approximation register to this register each time A/D conversion is completed, and the ADCR register holds the A/D conversion result in its higher 10 bits (the lower 6 bits are fixed to 0).

(7) 8-bit A/D conversion result register (ADCRH)

The A/D conversion result is loaded from the successive approximation register to this register each time A/D conversion is completed, and the ADCRH register stores the higher 8 bits of the A/D conversion result.

Caution When data is read from ADCR and ADCRH, a wait cycle is generated. For details, see CHAPTER 28 CAUTIONS FOR WAIT.

(8) Controller

This circuit controls the conversion time of an input analog signal that is to be converted into a digital signal, as well as starting and stopping of the conversion operation. When A/D conversion has been completed, this controller generates INTAD.

(9) AV_{REF} pin

This pin inputs an analog power/reference voltage to the A/D converter. Make this pin the same potential as the V_{DD} pin when port 2 is used as a digital port.

The signal input to ANI0 to ANI3 is converted into a digital signal, based on the voltage applied across AV_{REF} and AV_{SS}.

(10) AV_{SS} pin

This is the ground potential pin of the A/D converter. Always use this pin at the same potential as that of the V_{SS} pin even when the A/D converter is not used.

(11) A/D converter mode register (ADM)

This register is used to set the conversion time of the analog input signal to be converted, and to start or stop the conversion operation.

(12) A/D port configuration register (ADPC)

This register switches the ANI0/P20 to ANI3/P23 pins to analog input of A/D converter or digital I/O of port.

(13) Analog input channel specification register (ADS)

This register is used to specify the port that inputs the analog voltage to be converted into a digital signal.

(14) Port mode register 2 (PM2)

This register switches the ANI0/P20 to ANI3/P23 pins to input or output.

10.3 Registers Used in A/D Converter

The A/D converter uses the following six registers.

- A/D converter mode register (ADM)
- A/D port configuration register (ADPC)
- Analog input channel specification register (ADS)
- Port mode register 2 (PM2)
- 10-bit A/D conversion result register (ADCR)
- 8-bit A/D conversion result register (ADCRH)

(1) A/D converter mode register (ADM)

This register sets the conversion time for analog input to be A/D converted, and starts/stops conversion. ADM can be set by a 1-bit or 8-bit memory manipulation instruction. Reset signal generation sets this register to 00H.

Figure 10-3. Format of A/D Converter Mode Register (ADM)

Address: FF28H After reset: 00H R/W

Symbol	<7>	6	5	4	3	2	1	<0>
ADM	ADCS	0	FR2 ^{Note 1}	FR1 ^{Note 1}	FR0 ^{Note 1}	LV1 ^{Note 1}	LV0 ^{Note 1}	ADCE

ADCS	A/D conversion operation control
0	Stops conversion operation
1	Enables conversion operation

ADCE	Comparator operation control ^{Note 2}
0	Stops comparator operation
1	Enables comparator operation (comparator: 1/2 AV _{REF} operation)

- Notes**
1. For details of FR2 to FR0, LV1, LV0, and A/D conversion, see **Table 10-2 A/D Conversion Time Selection**.
 2. The operation of the comparator is controlled by ADCS and ADCE, and it takes 1 μs from operation start to operation stabilization. Therefore, when ADCS is set to 1 after 1 μs or more has elapsed from the time ADCE is set to 1, the conversion result at that time has priority over the first conversion result. Otherwise, ignore data of the first conversion.

Table 10-1. Settings of ADCS and ADCE

ADCS	ADCE	A/D Conversion Operation
0	0	Stop status (DC power consumption path does not exist)
0	1	Conversion waiting mode (comparator: 1/2 AV _{REF} operation, only comparator consumes power)
1	0	Conversion mode (comparator operation stopped ^{Note*})
1	1	Conversion mode (comparator: 1/2 AV _{REF} operation)

Note Ignore data of the first conversion because it is not guaranteed range.

Figure 10-4. Timing Chart When Comparator Is Used

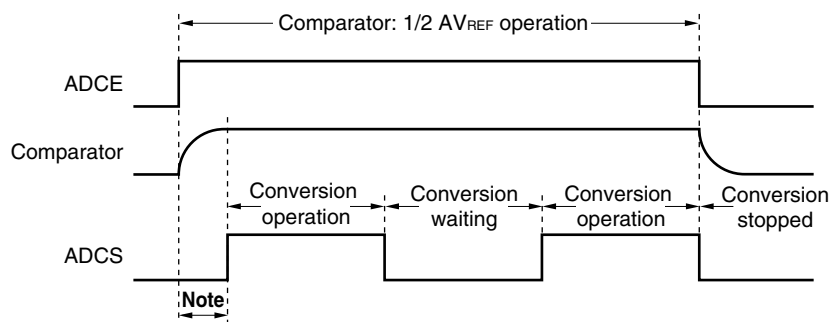

Note To stabilize the internal circuit, the time from the rising of the ADCE bit to the falling of the ADCS bit must be 1 μ s or longer.

- Cautions**
1. A/D conversion must be stopped before rewriting bits FR0 to FR2, LV1, and LV0 to values other than the identical data.
 2. If data is written to ADM, a wait cycle is generated. For details, see CHAPTER 28 CAUTIONS FOR WAIT.

Table 10-2. A/D Conversion Time Selection

(1) $2.7\text{ V} \leq AV_{REF} \leq 5.5\text{ V}$

A/D Converter Mode Register (ADM)					Conversion Time Selection			Conversion Clock (f_{AD})	
FR2	FR1	FR0	LV1	LV0		$f_{PRS} = 2\text{ MHz}$	$f_{PRS} = 10\text{ MHz}$		$f_{PRS} = 20\text{ MHz}^{\text{Note}}$
0	0	0	0	0	$264/f_{PRS}$	Setting prohibited	$26.4\ \mu\text{s}$	$13.2\ \mu\text{s}^{\text{Note}}$	$f_{PRS}/12$
0	0	1	0	0	$176/f_{PRS}$		$17.6\ \mu\text{s}$	$8.8\ \mu\text{s}^{\text{Note}}$	$f_{PRS}/8$
0	1	0	0	0	$132/f_{PRS}$		$13.2\ \mu\text{s}$	$6.6\ \mu\text{s}^{\text{Note}}$	$f_{PRS}/6$
0	1	1	0	0	$88/f_{PRS}$		$8.8\ \mu\text{s}^{\text{Note}}$	Setting prohibited	$f_{PRS}/4$
1	0	0	0	0	$66/f_{PRS}$	$33.0\ \mu\text{s}$	$6.6\ \mu\text{s}^{\text{Note}}$		$f_{PRS}/3$
1	0	1	0	0	$44/f_{PRS}$	$22.0\ \mu\text{s}$	Setting prohibited	$f_{PRS}/2$	
Other than above					Setting prohibited				

Note This can be set only when $4.0\text{ V} \leq AV_{REF} \leq 5.5\text{ V}$.

(2) $2.3\text{ V} \leq AV_{REF} < 2.7\text{ V}$

A/D Converter Mode Register (ADM)					Conversion Time Selection			Conversion Clock (f_{AD})
FR2	FR1	FR0	LV1	LV0		$f_{PRS} = 2\text{ MHz}$	$f_{PRS} = 5\text{ MHz}$	
0	0	0	0	1	$480/f_{PRS}$	Setting prohibited	Setting prohibited	$f_{PRS}/12$
0	0	1	0	1	$320/f_{PRS}$		$64.0\ \mu\text{s}$	$f_{PRS}/8$
0	1	0	0	1	$240/f_{PRS}$		$48.0\ \mu\text{s}$	$f_{PRS}/6$
0	1	1	0	1	$160/f_{PRS}$		$32.0\ \mu\text{s}$	$f_{PRS}/4$
1	0	0	0	1	$120/f_{PRS}$	$60.0\ \mu\text{s}$	Setting prohibited	$f_{PRS}/3$
1	0	1	0	1	$80/f_{PRS}$	$40.0\ \mu\text{s}$	Setting prohibited	$f_{PRS}/2$
Other than above					Setting prohibited			

Cautions 1. Set the conversion times with the following conditions.

- $4.0\text{ V} \leq AV_{REF} \leq 5.5\text{ V}$: $f_{AD} = 0.6$ to 3.6 MHz
 - $2.7\text{ V} \leq AV_{REF} < 4.0\text{ V}$: $f_{AD} = 0.6$ to 1.8 MHz
 - $2.3\text{ V} \leq AV_{REF} < 2.7\text{ V}$: $f_{AD} = 0.6$ to 1.48 MHz
2. When rewriting FR2 to FR0, LV1, and LV0 to other than the same data, stop A/D conversion once ($ADCS = 0$) beforehand.
 3. Change LV1 and LV0 from the default value, when $2.3\text{ V} \leq AV_{REF} < 2.7\text{ V}$.
 4. The above conversion time does not include clock frequency errors. Select conversion time, taking clock frequency errors into consideration.

Remark f_{PRS} : Peripheral hardware clock frequency

Figure 10-5. A/D Converter Sampling and A/D Conversion Timing

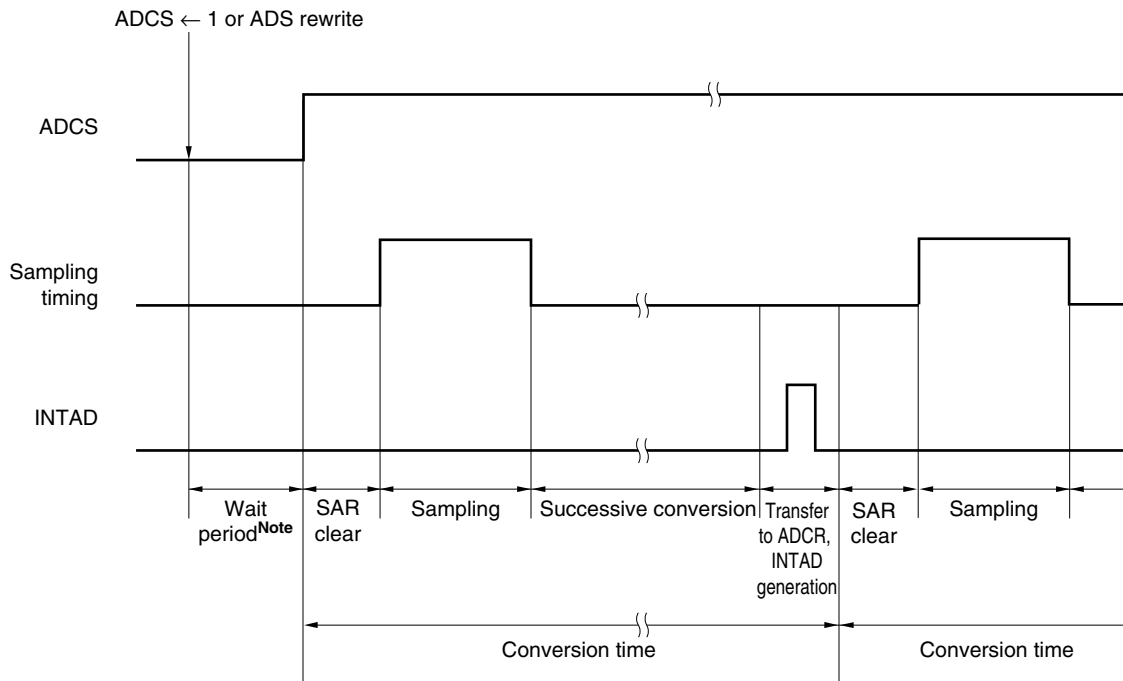

Note For details of wait period, see **CHAPTER 28 CAUTIONS FOR WAIT**.

(2) 10-bit A/D conversion result register (ADCR)

This register is a 16-bit register that stores the A/D conversion result. The lower 6 bits are fixed to 0. Each time A/D conversion ends, the conversion result is loaded from the successive approximation register. The higher 8 bits of the conversion result are stored in FF09H and the lower 2 bits are stored in the higher 2 bits of FF08H.

ADCR can be read by a 16-bit memory manipulation instruction.

Reset signal generation sets this register to 0000H.

Figure 10-6. Format of 10-Bit A/D Conversion Result Register (ADCR)

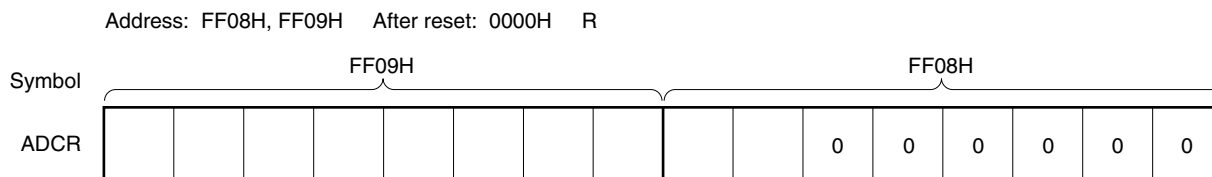

- Cautions**
1. When writing to the A/D converter mode register (ADM), analog input channel specification register (ADS), and A/D port configuration register (ADPC), the contents of ADCR may become undefined. Read the conversion result following conversion completion before writing to ADM, ADS, and ADPC. Using timing other than the above may cause an incorrect conversion result to be read.
 2. If data is read from ADCR, a wait cycle is generated. For details, see CHAPTER 28 CAUTIONS FOR WAIT.

(3) 8-bit A/D conversion result register (ADCRH)

This register is an 8-bit register that stores the A/D conversion result. The higher 8 bits of 10-bit resolution are stored.

ADCRH can be read by an 8-bit memory manipulation instruction.

Reset signal generation sets this register to 00H.

Figure 10-7. Format of 8-Bit A/D Conversion Result Register (ADCRH)

Address: FF09H After reset: 00H R

Symbol	7	6	5	4	3	2	1	0
ADCRH								

- Cautions**
1. When writing to the A/D converter mode register (ADM), analog input channel specification register (ADS), and A/D port configuration register (ADPC), the contents of ADCRH may become undefined. Read the conversion result following conversion completion before writing to ADM, ADS, and ADPC. Using timing other than the above may cause an incorrect conversion result to be read.
 2. If data is read from ADCRH, a wait cycle is generated. For details, see CHAPTER 28 CAUTIONS FOR WAIT.

(4) Analog input channel specification register (ADS)

This register specifies the input channel of the analog voltage to be A/D converted.

ADS can be set by a 1-bit or 8-bit memory manipulation instruction.

Reset signal generation sets this register to 00H.

Figure 10-8. Format of Analog Input Channel Specification Register (ADS)

Address: FF29H After reset: 00H R/W

Symbol	7	6	5	4	3	2	1	0
ADS	0	0	0	0	0	0	ADS1	ADS0

ADS1	ADS0	Analog input channel specification
0	0	ANI0
0	1	ANI1
1	0	ANI2
1	1	ANI3

- Cautions**
1. Be sure to clear bits 2 to 7 to 0.
 2. Set a channel to be used for A/D conversion in the input mode by using port mode register 2 (PM2).
 3. If data is written to ADS, a wait cycle is generated. For details, see CHAPTER 28 CAUTIONS FOR WAIT.

(5) A/D port configuration register (ADPC)

This register switches the ANI0/P20 to ANI3/P23 pins to analog input of A/D converter or digital I/O of port.

ADPC can be set by a 1-bit or 8-bit memory manipulation instruction.

Reset signal generation sets this register to 00H.

Figure 10-9. Format of A/D Port Configuration Register (ADPC)

Address: FF2FH After reset: 00H R/W

Symbol	7	6	5	4	3	2	1	0
ADPC	0	0	0	0	0	ADPC2	ADPC1	ADPC0

ADPC2	ADPC1	ADPC0	Digital I/O (D)/analog input (A) switching			
			P23/ANI3	P22/ANI2	P21/ANI1	P20/ANI0
0	0	0	A	A	A	A
0	0	1	A	A	A	D
0	1	0	A	A	D	D
0	1	1	A	D	D	D
1	0	0	D	D	D	D
Other than above			Setting prohibited			

- Cautions**
1. Be sure to clear bits 3 to 7 to 0.
 2. Set a channel to be used for A/D conversion in the input mode by using port mode register 2 (PM2).
 3. If data is written to ADPC, a wait cycle is generated. For details, see CHAPTER 28 CAUTIONS FOR WAIT.

(6) Port mode register 2 (PM2)

When using the ANI0/P20 to ANI3/P23 pins for analog input port, set PM20 to PM23 to 1. The output latches of P20 to P23 at this time may be 0 or 1.

If PM20 to PM23 are set to 0, they cannot be used as analog input port pins.

PM2 can be set by a 1-bit or 8-bit memory manipulation instruction.

Reset signal generation sets this register to FFH.

Figure 10-10. Format of Port Mode Register 2 (PM2)

Address: FF22H After reset: FFH R/W

Symbol	7	6	5	4	3	2	1	0
PM2	1	1	1	1	PM23	PM22	PM21	PM20

PM2n	P2n pin I/O mode selection (n = 0 to 3)
0	Output mode (output buffer on)
1	Input mode (output buffer off)

ANI0/P20 to ANI3/P23 pins are as shown below depending on the settings of ADPC, ADS, and PM2.

<R>

Table 10-3. Setting Functions of ANI0/P20 to ANI3/P23 Pins

ADPC	PM2	ADS	ANI0/P20 to ANI7/P27 Pin
Analog input selection	Input mode	Selects ANI.	Analog input (to be converted)
		Does not select ANI.	Analog input (not to be converted)
	Output mode	Selects ANI.	Setting prohibited
		Does not select ANI.	
Digital I/O selection	Input mode	–	Digital input
	Output mode	–	Digital output

10.4 A/D Converter Operations

10.4.1 Basic operations of A/D converter

- <1> Set bit 0 (ADCE) of the A/D converter mode register (ADM) to 1 to start the operation of the comparator.
- <2> Set channels for A/D conversion to analog input by using the A/D port configuration register (ADPC) and set to input mode by using port mode register 2 (PM2).
- <3> Set A/D conversion time by using bits 5 to 1 (FR2 to FR0, LV1, and LV0) of ADM.
- <4> Select one channel for A/D conversion using the analog input channel specification register (ADS).
- <5> Start the conversion operation by setting bit 7 (ADCS) of ADM to 1.
(<6> to <12> are operations performed by hardware.)
- <6> The voltage input to the selected analog input channel is sampled by the sample & hold circuit.
- <7> When sampling has been done for a certain time, the sample & hold circuit is placed in the hold state and the sampled voltage is held until the A/D conversion operation has ended.
- <8> Bit 9 of the successive approximation register (SAR) is set. The series resistor string voltage tap is set to $(1/2) AV_{REF}$ by the tap selector.
- <9> The voltage difference between the series resistor string voltage tap and sampled voltage is compared by the voltage comparator. If the analog input is greater than $(1/2) AV_{REF}$, the MSB of SAR remains set to 1. If the analog input is smaller than $(1/2) AV_{REF}$, the MSB is reset to 0.
- <10> Next, bit 8 of SAR is automatically set to 1, and the operation proceeds to the next comparison. The series resistor string voltage tap is selected according to the preset value of bit 9, as described below.
 - Bit 9 = 1: $(3/4) AV_{REF}$
 - Bit 9 = 0: $(1/4) AV_{REF}$
 The voltage tap and sampled voltage are compared and bit 8 of SAR is manipulated as follows.
 - Analog input voltage \geq Voltage tap: Bit 8 = 1
 - Analog input voltage $<$ Voltage tap: Bit 8 = 0
- <11> Comparison is continued in this way up to bit 0 of SAR.
- <12> Upon completion of the comparison of 10 bits, an effective digital result value remains in SAR, and the result value is transferred to the A/D conversion result register (ADCR, ADCRH) and then latched.
At the same time, the A/D conversion end interrupt request (INTAD) can also be generated.
- <13> Repeat steps <6> to <12>, until ADCS is cleared to 0.
To stop the A/D converter, clear ADCS to 0.
To restart A/D conversion from the status of ADCE = 1, start from <5>. To start A/D conversion again when ADCE = 0, set ADCE to 1, wait for 1 μ s or longer, and start <5>. To change a channel of A/D conversion, start from <4>.

Caution Make sure the period of <1> to <5> is 1 μ s or more.

Remark Two types of A/D conversion result registers are available.

- ADCR (16 bits): Store 10-bit A/D conversion value
- ADCRH (8 bits): Store 8-bit A/D conversion value

Figure 10-11. Basic Operation of A/D Converter

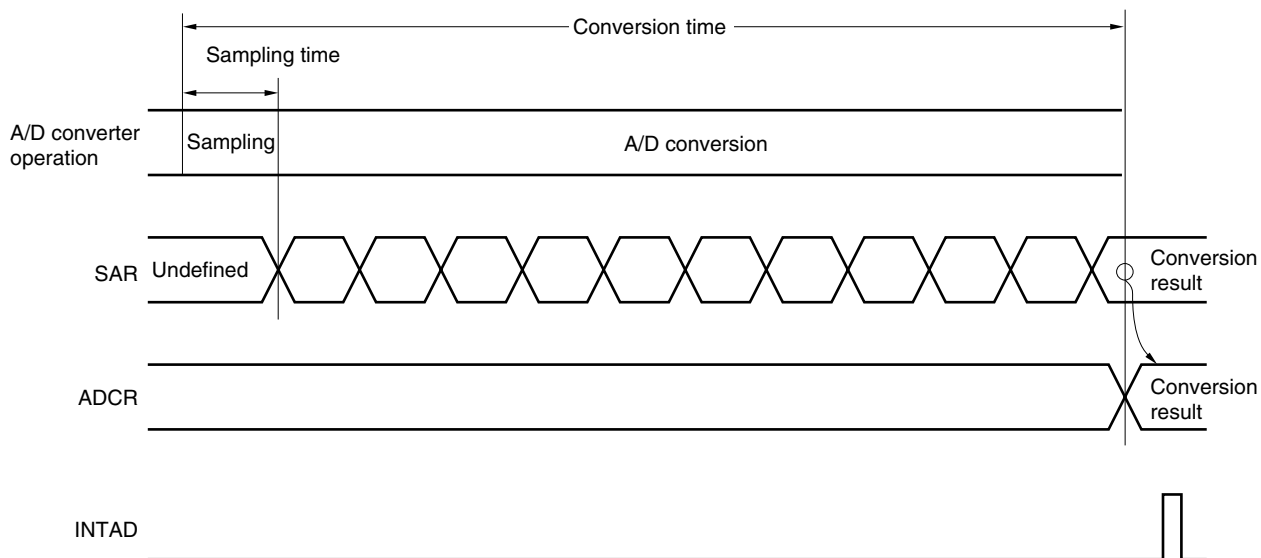

A/D conversion operations are performed continuously until bit 7 (ADCS) of the A/D converter mode register (ADM) is reset (0) by software.

If a write operation is performed to the analog input channel specification register (ADS) during an A/D conversion operation, the conversion operation is initialized, and if the ADCS bit is set (1), conversion starts again from the beginning.

Reset signal generation sets the A/D conversion result register (ADCR, ADCRH) to 0000H or 00H.

10.4.2 Input voltage and conversion results

The relationship between the analog input voltage input to the analog input pins (ANI0 to ANI3) and the theoretical A/D conversion result (stored in the 10-bit A/D conversion result register (ADCR)) is shown by the following expression.

$$SAR = INT \left(\frac{V_{AIN}}{AV_{REF}} \times 1024 + 0.5 \right)$$

$$ADCR = SAR \times 64$$

or

$$\left(\frac{ADCR}{64} - 0.5 \right) \times \frac{AV_{REF}}{1024} \leq V_{AIN} < \left(\frac{ADCR}{64} + 0.5 \right) \times \frac{AV_{REF}}{1024}$$

where, INT(): Function which returns integer part of value in parentheses

V_{AIN} : Analog input voltage

AV_{REF} : AV_{REF} pin voltage

ADCR: A/D conversion result register (ADCR) value

SAR: Successive approximation register

Figure 10-12 shows the relationship between the analog input voltage and the A/D conversion result.

Figure 10-12. Relationship Between Analog Input Voltage and A/D Conversion Result

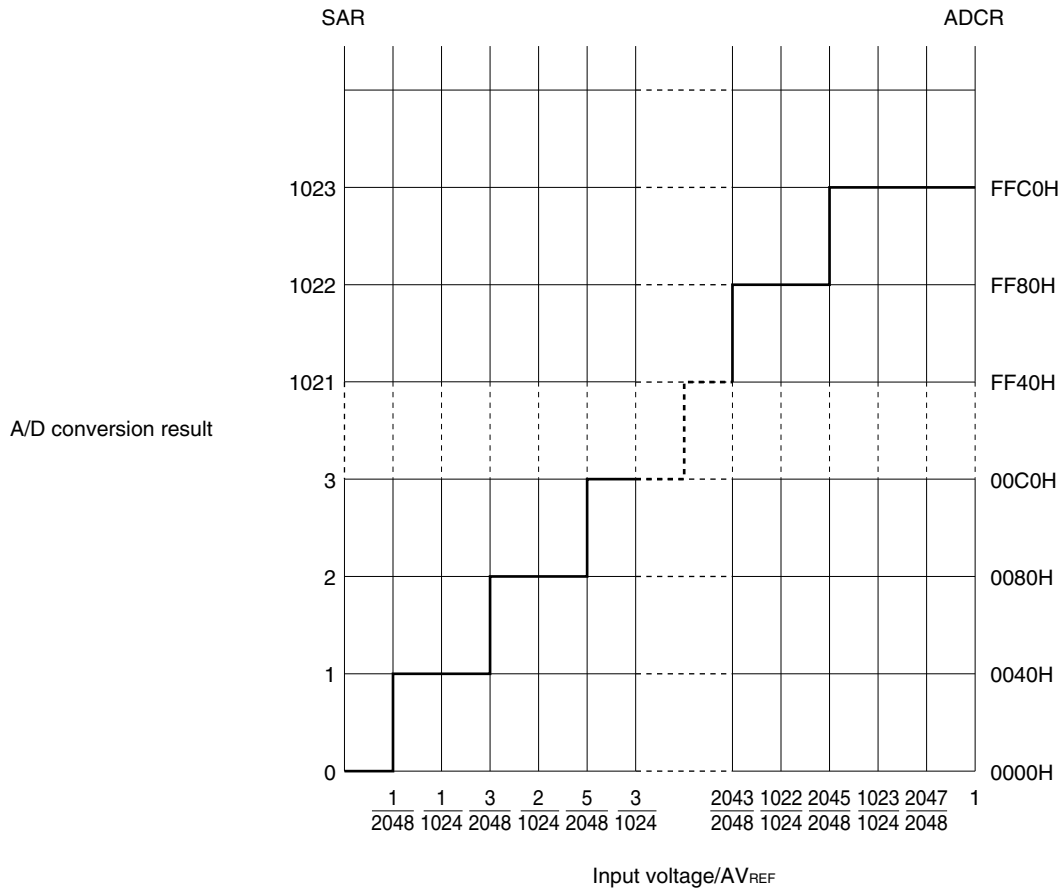

10.4.3 A/D converter operation mode

The operation mode of the A/D converter is the select mode. One channel of analog input is selected from ANI0 to ANI3 by the analog input channel specification register (ADS) and A/D conversion is executed.

(1) A/D conversion operation

By setting bit 7 (ADCS) of the A/D converter mode register (ADM) to 1, the A/D conversion operation of the voltage, which is applied to the analog input pin specified by the analog input channel specification register (ADS), is started.

When A/D conversion has been completed, the result of the A/D conversion is stored in the A/D conversion result register (ADCR), and an interrupt request signal (INTAD) is generated. When one A/D conversion has been completed, the next A/D conversion operation is immediately started.

If ADS is rewritten during A/D conversion, the A/D conversion operation under execution is stopped and restarted from the beginning.

If 0 is written to ADCS during A/D conversion, A/D conversion is immediately stopped. At this time, the conversion result immediately before is retained.

Figure 10-13. A/D Conversion Operation

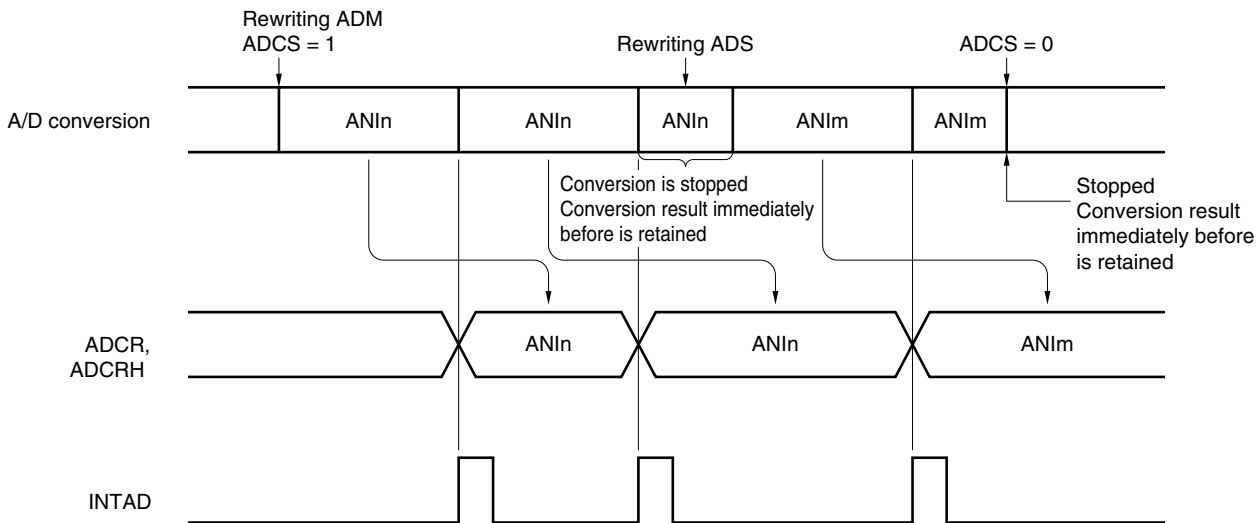

- Remarks 1.** n = 0 to 3
- 2.** m = 0 to 3

The setting methods are described below.

- <1> Set bit 0 (ADCE) of the A/D converter mode register (ADM) to 1.
 - <2> Set the channel to be used in the analog input mode by using bits 2 to 0 (ADPC2 to ADPC0) of the A/D port configuration register (ADPC) and bits 3 to 0 (PM23 to PM20) of port mode register 2 (PM2).
 - <3> Select conversion time by using bits 5 to 1 (FR2 to FR0, LV1, and LV0) of ADM.
 - <4> Select a channel to be used by using bits 1 and 0 (ADS1 and ADS0) of the analog input channel specification register (ADS).
 - <5> Set bit 7 (ADCS) of ADM to 1 to start A/D conversion.
 - <6> When one A/D conversion has been completed, an interrupt request signal (INTAD) is generated.
 - <7> Transfer the A/D conversion data to the A/D conversion result register (ADCR, ADCRH).
- <Change the channel>
- <8> Change the channel using bits 1 and 0 (ADS1 and ADS0) of ADS to start A/D conversion.
 - <9> When one A/D conversion has been completed, an interrupt request signal (INTAD) is generated.
 - <10> Transfer the A/D conversion data to the A/D conversion result register (ADCR, ADCRH).
- <Complete A/D conversion>
- <11> Clear ADCS to 0.
 - <12> Clear ADCE to 0.

- Cautions**
1. Make sure the period of <1> to <5> is 1 μ s or more.
 2. <1> may be done between <2> and <4>.
 3. <1> can be omitted. However, ignore data of the first conversion after <5> in this case.
 4. The period from <6> to <9> differs from the conversion time set using bits 5 to 1 (FR2 to FR0, LV1, LV0) of ADM. The period from <8> to <9> is the conversion time set using FR2 to FR0, LV1, and LV0.

10.5 How to Read A/D Converter Characteristics Table

Here, special terms unique to the A/D converter are explained.

(1) Resolution

This is the minimum analog input voltage that can be identified. That is, the percentage of the analog input voltage per bit of digital output is called 1LSB (Least Significant Bit). The percentage of 1LSB with respect to the full scale is expressed by %FSR (Full Scale Range).

1LSB is as follows when the resolution is 10 bits.

$$1\text{LSB} = 1/2^{10} = 1/1024$$

$$= 0.098\%\text{FSR}$$

Accuracy has no relation to resolution, but is determined by overall error.

(2) Overall error

This shows the maximum error value between the actual measured value and the theoretical value.

Zero-scale error, full-scale error, integral linearity error, and differential linearity errors that are combinations of these express the overall error.

Note that the quantization error is not included in the overall error in the characteristics table.

(3) Quantization error

When analog values are converted to digital values, a $\pm 1/2\text{LSB}$ error naturally occurs. In an A/D converter, an analog input voltage in a range of $\pm 1/2\text{LSB}$ is converted to the same digital code, so a quantization error cannot be avoided.

Note that the quantization error is not included in the overall error, zero-scale error, full-scale error, integral linearity error, and differential linearity error in the characteristics table.

Figure 10-14. Overall Error

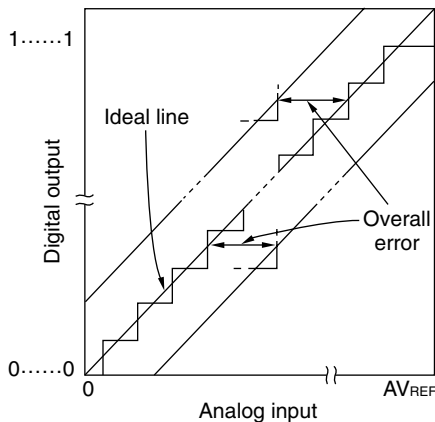
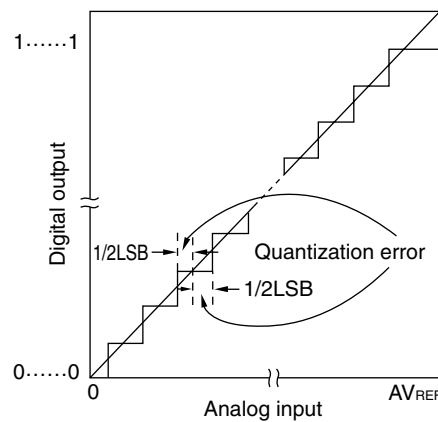

Figure 10-15. Quantization Error



(4) Zero-scale error

This shows the difference between the actual measurement value of the analog input voltage and the theoretical value ($1/2\text{LSB}$) when the digital output changes from $0.....000$ to $0.....001$.

If the actual measurement value is greater than the theoretical value, it shows the difference between the actual measurement value of the analog input voltage and the theoretical value ($3/2\text{LSB}$) when the digital output changes from $0.....001$ to $0.....010$.

(5) Full-scale error

This shows the difference between the actual measurement value of the analog input voltage and the theoretical value (Full-scale – 3/2LSB) when the digital output changes from 1.....110 to 1.....111.

(6) Integral linearity error

This shows the degree to which the conversion characteristics deviate from the ideal linear relationship. It expresses the maximum value of the difference between the actual measurement value and the ideal straight line when the zero-scale error and full-scale error are 0.

(7) Differential linearity error

While the ideal width of code output is 1LSB, this indicates the difference between the actual measurement value and the ideal value.

Figure 10-16. Zero-Scale Error

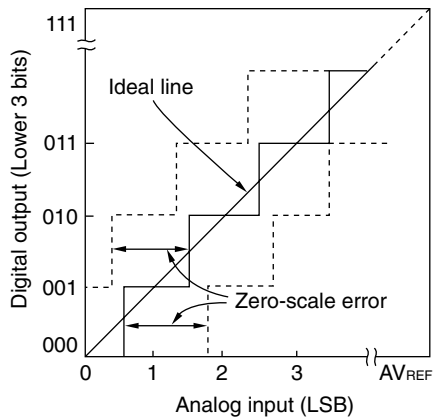

Figure 10-17. Full-Scale Error

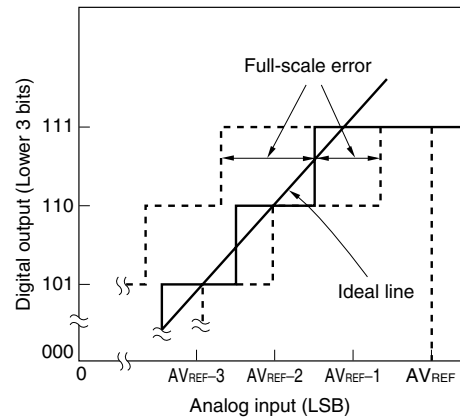

Figure 10-18. Integral Linearity Error

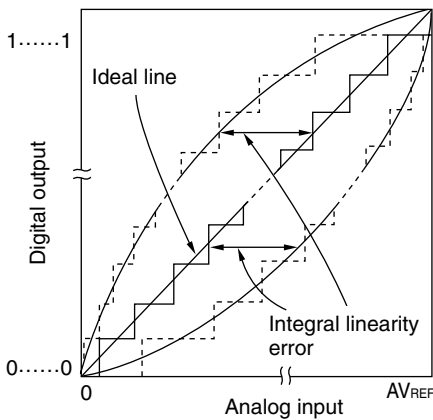
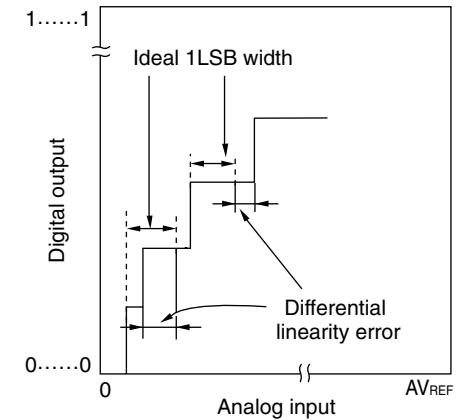

Figure 10-19. Differential Linearity Error



(8) Conversion time

This expresses the time from the start of sampling to when the digital output is obtained. The sampling time is included in the conversion time in the characteristics table.

(9) Sampling time

This is the time the analog switch is turned on for the analog voltage to be sampled by the sample & hold circuit.

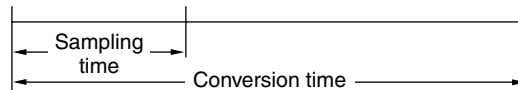

10.6 Cautions for A/D Converter

(1) Operating current in STOP mode

The A/D converter stops operating in the STOP mode. At this time, the operating current can be reduced by clearing bit 7 (ADCS) and bit 0 (ADCE) of the A/D converter mode register (ADM) to 0.

To restart from the standby status, clear bit 0 (ADIF) of interrupt request flag register 1L (IF1L) to 0 and start operation.

(2) Input range of ANI0 to ANI3

Observe the rated range of the ANI0 to ANI3 input voltage. If a voltage of AV_{REF} or higher and AV_{SS} or lower (even in the range of absolute maximum ratings) is input to an analog input channel, the converted value of that channel becomes undefined. In addition, the converted values of the other channels may also be affected.

(3) Conflicting operations

<1> Conflict between A/D conversion result register (ADCR, ADCRH) write and ADCR or ADCRH read by instruction upon the end of conversion

ADCR or ADCRH read has priority. After the read operation, the new conversion result is written to ADCR or ADCRH.

<2> Conflict between ADCR or ADCRH write and A/D converter mode register (ADM) write, analog input channel specification register (ADS), or A/D port configuration register (ADPC) write upon the end of conversion

ADM, ADS, or ADPC write has priority. ADCR or ADCRH write is not performed, nor is the conversion end interrupt signal (INTAD) generated.

(4) Noise countermeasures

To maintain the 10-bit resolution, attention must be paid to noise input to the AV_{REF} pin and pins ANI0 to ANI3.

<1> Connect a capacitor with a low equivalent resistance and a good frequency response to the power supply.

<2> The higher the output impedance of the analog input source, the greater the influence. To reduce the noise, connecting external C as shown in Figure 10-20 is recommended.

<3> Do not switch these pins with other pins during conversion.

<4> The accuracy is improved if the HALT mode is set immediately after the start of conversion.

Figure 10-20. Analog Input Pin Connection

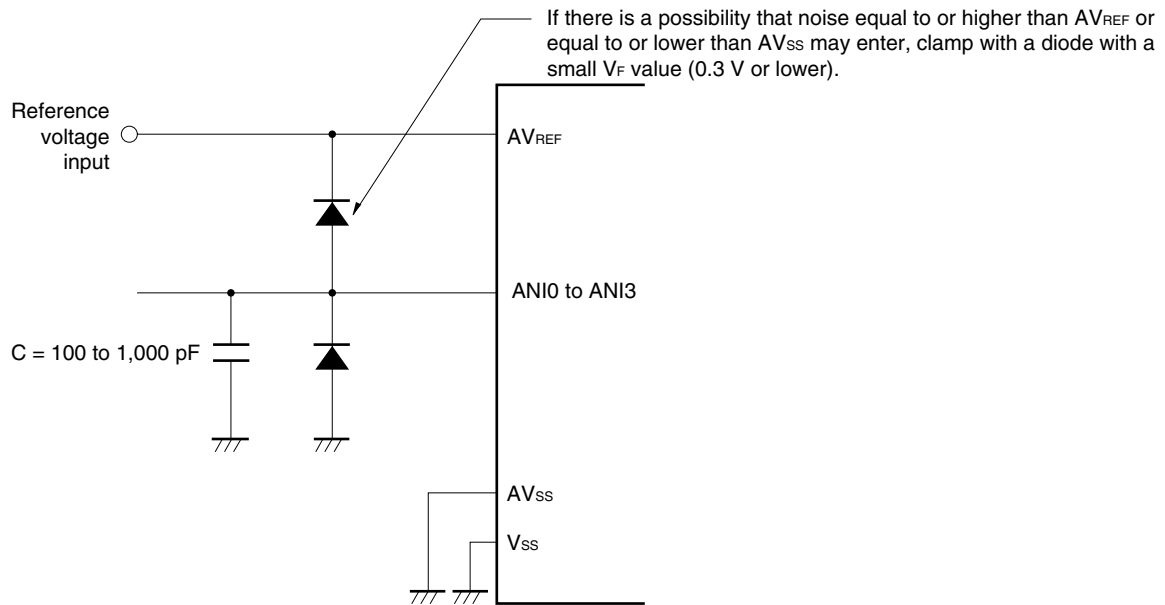
**(5) ANI0/P20 to ANI3/P23**

<1> The analog input pins (ANI0 to ANI3) are also used as input port pins (P20 to P23).

When A/D conversion is performed with any of ANI0 to ANI3 selected, do not access P20 to P23 while conversion is in progress; otherwise the conversion resolution may be degraded. It is recommended to select pins used as P20 to P23 starting with the ANI0/P20 that is the furthest from AVREF.

<2> If a digital pulse is applied to the pins adjacent to the pins currently used for A/D conversion, the expected value of the A/D conversion may not be obtained due to coupling noise. Therefore, do not apply a pulse to the pins adjacent to the pin undergoing A/D conversion.

(6) Input impedance of ANI0 to ANI3 pins

This A/D converter charges a sampling capacitor for sampling during sampling time.

Therefore, only a leakage current flows when sampling is not in progress, and a current that charges the capacitor flows during sampling. Consequently, the input impedance fluctuates depending on whether sampling is in progress, and on the other states.

To make sure that sampling is effective, however, it is recommended to keep the output impedance of the analog input source to within 10 k Ω , and to connect a capacitor of about 100 pF to the ANI0 to ANI3 pins (see **Figure 10-20**).

(7) AVREF pin input impedance

A series resistor string of several tens of k Ω is connected between the AVREF and AVSS pins.

Therefore, if the output impedance of the reference voltage source is high, this will result in a series connection to the series resistor string between the AVREF and AVSS pins, resulting in a large reference voltage error.

(8) Interrupt request flag (ADIF)

The interrupt request flag (ADIF) is not cleared even if the analog input channel specification register (ADS) is changed.

Therefore, if an analog input pin is changed during A/D conversion, the A/D conversion result and ADIF for the pre-change analog input may be set just before the ADS rewrite. Caution is therefore required since, at this time, when ADIF is read immediately after the ADS rewrite, ADIF is set despite the fact A/D conversion for the post-change analog input has not ended.

When A/D conversion is stopped and then resumed, clear ADIF before the A/D conversion operation is resumed.

Figure 10-21. Timing of A/D Conversion End Interrupt Request Generation

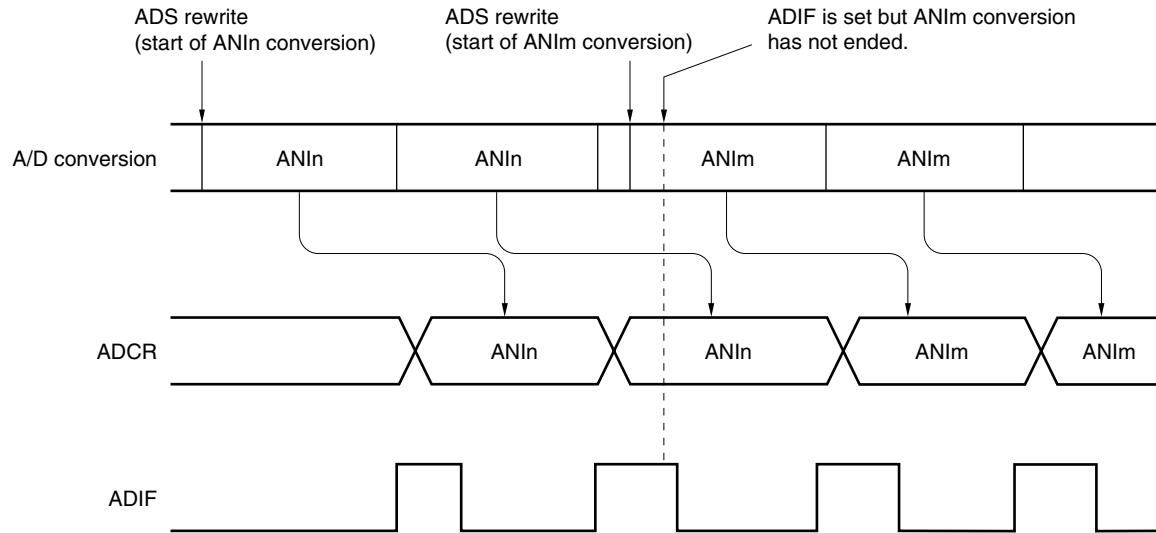

Remarks 1. $n = 0$ to 3

2. $m = 0$ to 3

(9) Conversion results just after A/D conversion start

The first A/D conversion value immediately after A/D conversion starts may not fall within the rating range if the ADCS bit is set to 1 within 1 μ s after the ADCE bit was set to 1, or if the ADCS bit is set to 1 with the ADCE bit = 0. Take measures such as polling the A/D conversion end interrupt request (INTAD) and removing the first conversion result.

(10) A/D conversion result register (ADCR, ADCRH) read operation

When a write operation is performed to the A/D converter mode register (ADM), analog input channel specification register (ADS), and A/D port configuration register (ADPC), the contents of ADCR and ADCRH may become undefined. Read the conversion result following conversion completion before writing to ADM, ADS, and ADPC. Using a timing other than the above may cause an incorrect conversion result to be read.

(11) Internal equivalent circuit

The equivalent circuit of the analog input block is shown below.

Figure 10-22. Internal Equivalent Circuit of ANIn Pin

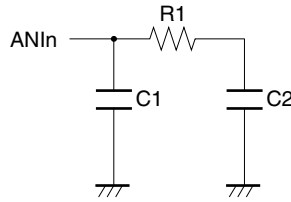

Table 10-4. Resistance and Capacitance Values of Equivalent Circuit (Reference Values)

AV_{REF}	R1	C1	C2
$4.0\text{ V} \leq AV_{REF} \leq 5.5\text{ V}$	8.1 k Ω	8 pF	5 pF
$2.7\text{ V} \leq AV_{REF} < 4.0\text{ V}$	31 k Ω	8 pF	5 pF
$2.3\text{ V} \leq AV_{REF} < 2.7\text{ V}$	381 k Ω	8 pF	5 pF

- Remarks**
1. The resistance and capacitance values shown in Table 10-4 are not guaranteed values.
 2. n = 0 to 3

CHAPTER 11 SERIAL INTERFACE UART0

11.1 Functions of Serial Interface UART0

Serial interface UART0 has the following two modes.

(1) Operation stop mode

This mode is used when serial communication is not executed and can enable a reduction in the power consumption.

For details, see **11.4.1 Operation stop mode**.

(2) Asynchronous serial interface (UART) mode

The functions of this mode are outlined below.

For details, see **11.4.2 Asynchronous serial interface (UART) mode** and **11.4.3 Dedicated baud rate generator**.

<R>

- Maximum transfer rate: 625 kbps
- Two-pin configuration TxD0: Transmit data output pin
RxD0: Receive data input pin
- Length of communication data can be selected from 7 or 8 bits.
- Dedicated on-chip 5-bit baud rate generator allowing any baud rate to be set
- Transmission and reception can be performed independently (full-duplex operation).
- Fixed to LSB-first communication

- Cautions**
1. If clock supply to serial interface UART0 is not stopped (e.g., in the HALT mode), normal operation continues. If clock supply to serial interface UART0 is stopped (e.g., in the STOP mode), each register stops operating, and holds the value immediately before clock supply was stopped. The TxD0 pin also holds the value immediately before clock supply was stopped and outputs it. However, the operation is not guaranteed after clock supply is resumed. Therefore, reset the circuit so that POWER0 = 0, RXE0 = 0, and TXE0 = 0.
 2. Set POWER0 = 1 and then set TXE0 = 1 (transmission) or RXE0 = 1 (reception) to start communication.
 3. TXE0 and RXE0 are synchronized by the base clock (f_{XCLK0}) set by BRGC0. To enable transmission or reception again, set TXE0 or RXE0 to 1 at least two clocks of base clock after TXE0 or RXE0 has been cleared to 0. If TXE0 or RXE0 is set within two clocks of base clock, the transmission circuit or reception circuit may not be initialized.
 4. Set transmit data to TXS0 at least one base clock (f_{XCLK0}) after setting TXE0 = 1.

11.2 Configuration of Serial Interface UART0

Serial interface UART0 includes the following hardware.

Table 11-1. Configuration of Serial Interface UART0

Item	Configuration
Registers	Receive buffer register 0 (RXB0) Receive shift register 0 (RXS0) Transmit shift register 0 (TXS0)
Control registers	Asynchronous serial interface operation mode register 0 (ASIM0) Asynchronous serial interface reception error status register 0 (ASIS0) Baud rate generator control register 0 (BRGC0) Port mode register 1 (PM1) Port register 1 (P1)

Figure 11-1. Block Diagram of Serial Interface UART0

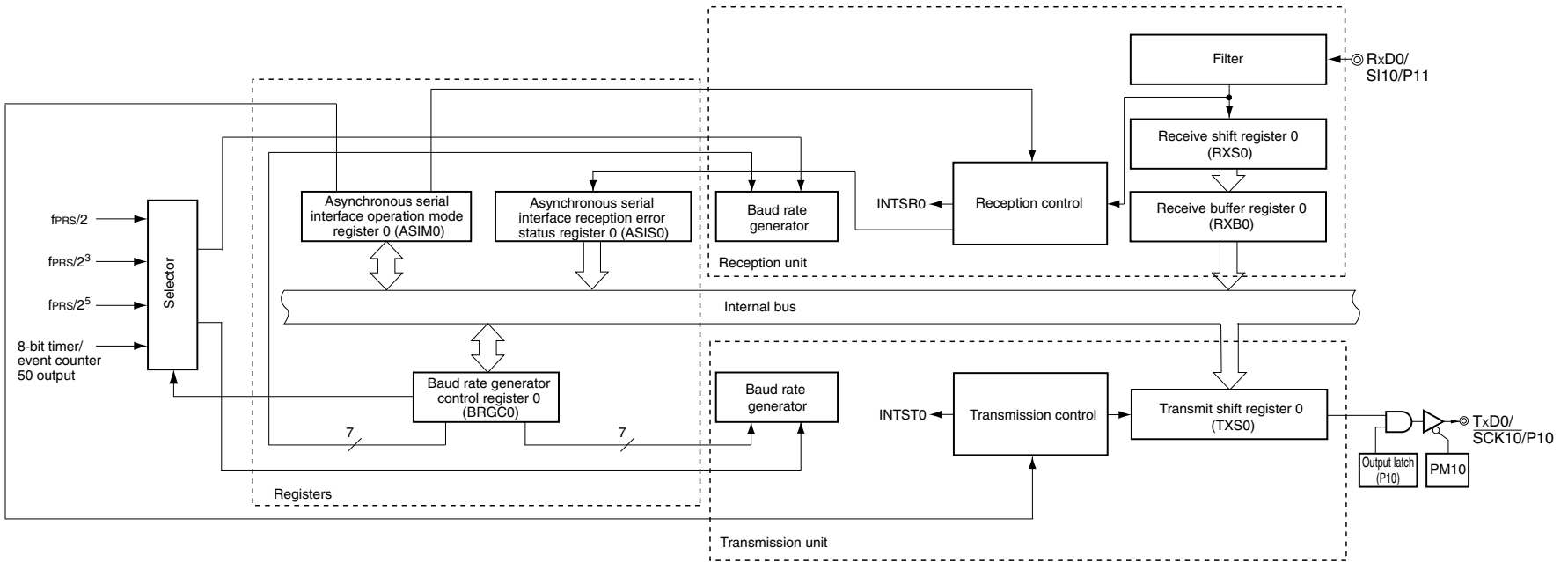

(1) Receive buffer register 0 (RXB0)

This 8-bit register stores parallel data converted by receive shift register 0 (RXS0).

Each time 1 byte of data has been received, new receive data is transferred to this register from receive shift register 0 (RXS0).

If the data length is set to 7 bits the receive data is transferred to bits 0 to 6 of RXB0 and the MSB of RXB0 is always 0.

If an overrun error (OVE0) occurs, the receive data is not transferred to RXB0.

RXB0 can be read by an 8-bit memory manipulation instruction. No data can be written to this register.

Reset signal generation and POWER0 = 0 set this register to FFH.

(2) Receive shift register 0 (RXS0)

This register converts the serial data input to the RxD0 pin into parallel data.

RXS0 cannot be directly manipulated by a program.

(3) Transmit shift register 0 (TXS0)

This register is used to set transmit data. Transmission is started when data is written to TXS0, and serial data is transmitted from the TxD0 pins.

TXS0 can be written by an 8-bit memory manipulation instruction. This register cannot be read.

Reset signal generation, POWER0 = 0, and TXE0 = 0 set this register to FFH.

Cautions 1. Set transmit data to TXS0 at least one base clock (f_{CLK0}) after setting TXE0 = 1.

2. Do not write the next transmit data to TXS0 before the transmission completion interrupt signal (INTST0) is generated.

11.3 Registers Controlling Serial Interface UART0

Serial interface UART0 is controlled by the following five registers.

- Asynchronous serial interface operation mode register 0 (ASIM0)
- Asynchronous serial interface reception error status register 0 (ASIS0)
- Baud rate generator control register 0 (BRGC0)
- Port mode register 1 (PM1)
- Port register 1 (P1)

(1) Asynchronous serial interface operation mode register 0 (ASIM0)

This 8-bit register controls the serial communication operations of serial interface UART0.

This register can be set by a 1-bit or 8-bit memory manipulation instruction.

Reset signal generation sets this register to 01H.

Figure 11-2. Format of Asynchronous Serial Interface Operation Mode Register 0 (ASIM0) (1/2)

Address: FF70H After reset: 01H R/W

Symbol	<7>	<6>	<5>	4	3	2	1	0
ASIM0	POWER0	TXE0	RXE0	PS01	PS00	CL0	SL0	1

POWER0	Enables/disables operation of internal operation clock
0 ^{Note 1}	Disables operation of the internal operation clock (fixes the clock to low level) and asynchronously resets the internal circuit ^{Note 2} .
1	Enables operation of the internal operation clock.

TXE0	Enables/disables transmission
0	Disables transmission (synchronously resets the transmission circuit).
1	Enables transmission.

RXE0	Enables/disables reception
0	Disables reception (synchronously resets the reception circuit).
1	Enables reception.

- Notes**
1. The input from the RxD0 pin is fixed to high level when POWER0 = 0.
 2. Asynchronous serial interface reception error status register 0 (ASIS0), transmit shift register 0 (TXS0), and receive buffer register 0 (RXB0) are reset.

Figure 11-2. Format of Asynchronous Serial Interface Operation Mode Register 0 (ASIM0) (2/2)

PS01	PS00	Transmission operation	Reception operation
0	0	Does not output parity bit.	Reception without parity
0	1	Outputs 0 parity.	Reception as 0 parity ^{Note}
1	0	Outputs odd parity.	Judges as odd parity.
1	1	Outputs even parity.	Judges as even parity.

CL0	Specifies character length of transmit/receive data
0	Character length of data = 7 bits
1	Character length of data = 8 bits

SL0	Specifies number of stop bits of transmit data
0	Number of stop bits = 1
1	Number of stop bits = 2

Note If “reception as 0 parity” is selected, the parity is not judged. Therefore, bit 2 (PE0) of asynchronous serial interface reception error status register 0 (ASIS0) is not set and the error interrupt does not occur.

- Cautions**
1. To start the transmission, set POWER0 to 1 and then set TXE0 to 1. To stop the transmission, clear TXE0 to 0, and then clear POWER0 to 0.
 2. To start the reception, set POWER0 to 1 and then set RXE0 to 1. To stop the reception, clear RXE0 to 0, and then clear POWER0 to 0.
 3. Set POWER0 to 1 and then set RXE0 to 1 while a high level is input to the RxD0 pin. If POWER0 is set to 1 and RXE0 is set to 1 while a low level is input, reception is started.
 4. TXE0 and RXE0 are synchronized by the base clock (f_{XCLK0}) set by BRGC0. To enable transmission or reception again, set TXE0 or RXE0 to 1 at least two clocks of base clock after TXE0 or RXE0 has been cleared to 0. If TXE0 or RXE0 is set within two clocks of base clock, the transmission circuit or reception circuit may not be initialized.
 5. Set transmit data to TXS0 at least one base clock (f_{XCLK0}) after setting TXE0 = 1.
 6. Clear the TXE0 and RXE0 bits to 0 before rewriting the PS01, PS00, and CL0 bits.
 7. Make sure that TXE0 = 0 when rewriting the SL0 bit. Reception is always performed with “number of stop bits = 1”, and therefore, is not affected by the set value of the SL0 bit.
 8. Be sure to set bit 0 to 1.

(2) Asynchronous serial interface reception error status register 0 (ASIS0)

This register indicates an error status on completion of reception by serial interface UART0. It includes three error flag bits (PE0, FE0, OVE0).

This register is read-only by an 8-bit memory manipulation instruction.

Reset signal generation, or clearing bit 7 (POWER6) or bit 5 (RXE6) of ASIM6 to 0 clears this register to 00H. when this register is read. If a reception error occurs, read ASIS0 and then read receive buffer register 0 (RXB0) to clear the error flag.

Figure 11-3. Format of Asynchronous Serial Interface Reception Error Status Register 0 (ASIS0)

Address: FF73H After reset: 00H R

Symbol	7	6	5	4	3	2	1	0
ASIS0	0	0	0	0	0	PE0	FE0	OVE0

PE0	Status flag indicating parity error
0	If POWER0 = 0 or RXE0 = 0, or if ASIS0 register is read.
1	If the parity of transmit data does not match the parity bit on completion of reception.

FE0	Status flag indicating framing error
0	If POWER0 = 0 or RXE0 = 0, or if ASIS0 register is read.
1	If the stop bit is not detected on completion of reception.

OVE0	Status flag indicating overrun error
0	If POWER0 = 0 or RXE0 = 0, or if ASIS0 register is read.
1	If receive data is set to the RXB0 register and the next reception operation is completed before the data is read.

- Cautions**
1. The operation of the PE0 bit differs depending on the set values of the PS01 and PS00 bits of asynchronous serial interface operation mode register 0 (ASIM0).
 2. For the stop bit of the receive data, only the first stop bit is checked regardless of the number of stop bits.
 3. If an overrun error occurs, the next receive data is not written to receive buffer register 0 (RXB0) but discarded.
 4. If data is read from ASIS0, a wait cycle is generated. For details, see CHAPTER 28 CAUTIONS FOR WAIT.

(3) Baud rate generator control register 0 (BRGC0)

This register selects the base clock of serial interface UART0 and the division value of the 5-bit counter. BRGC0 can be set by an 8-bit memory manipulation instruction. Reset signal generation sets this register to 1FH.

Figure 11-4. Format of Baud Rate Generator Control Register 0 (BRGC0)

Address: FF71H After reset: 1FH R/W

Symbol	7	6	5	4	3	2	1	0
BRGC0	TPS01	TPS00	0	MDL04	MDL03	MDL02	MDL01	MDL00

TPS01	TPS00	Base clock (f _{XCLK0}) selection				
		f _{PRS} = 2 MHz	f _{PRS} = 5 MHz	f _{PRS} = 10 MHz	f _{PRS} = 20 MHz	
0	0	TM50 output ^{Note}				
0	1	f _{PRS} /2	1 MHz	2.5 MHz	5 MHz	10 MHz
1	0	f _{PRS} /2 ³	250 kHz	625 kHz	1.25 MHz	2.5 MHz
1	1	f _{PRS} /2 ⁵	62.5 kHz	156.25 kHz	312.5 kHz	625 kHz

MDL04	MDL03	MDL02	MDL01	MDL00	k	Selection of 5-bit counter output clock
0	0	×	×	×	×	Setting prohibited
0	1	0	0	0	8	f _{XCLK0} /8
0	1	0	0	1	9	f _{XCLK0} /9
0	1	0	1	0	10	f _{XCLK0} /10
•	•	•	•	•	•	•
•	•	•	•	•	•	•
•	•	•	•	•	•	•
•	•	•	•	•	•	•
•	•	•	•	•	•	•
1	1	0	1	0	26	f _{XCLK0} /26
1	1	0	1	1	27	f _{XCLK0} /27
1	1	1	0	0	28	f _{XCLK0} /28
1	1	1	0	1	29	f _{XCLK0} /29
1	1	1	1	0	30	f _{XCLK0} /30
1	1	1	1	1	31	f _{XCLK0} /31

- Note** Note the following points when selecting the TM50 output as the base clock.
- Mode in which the count clock is cleared and started upon a match of TM50 and CR50 (TMC506 = 0)
Start the operation of 8-bit timer/event counter 50 first and then enable the timer F/F inversion operation (TMC501 = 1).
 - PWM mode (TMC506 = 1)
Start the operation of 8-bit timer/event counter 50 first and then set the count clock to make the duty = 50%.
- It is not necessary to enable the TO50 pin as a timer output pin in any mode.

- Cautions**
1. Make sure that bit 6 (TXE0) and bit 5 (RXE0) of the ASIM0 register = 0 when rewriting the MDL04 to MDL00 bits.
 2. The baud rate value is the output clock of the 5-bit counter divided by 2.

- Remarks**
1. f_{CLK0} : Frequency of base clock selected by the TPS01 and TPS00 bits
 2. f_{PRS} : Peripheral hardware clock frequency
 3. k: Value set by the MDL04 to MDL00 bits (k = 8, 9, 10, ..., 31)
 4. x: Don't care
 5. TMC506: Bit 6 of 8-bit timer mode control register 50 (TMC50)
TMC501: Bit 1 of TMC50

(4) Port mode register 1 (PM1)

This register sets port 1 input/output in 1-bit units.

When using the P10/TxD0/ $\overline{SCK10}$ pin for serial interface data output, clear PM10 to 0 and set the output latch of P10 to 1.

When using the P11/RxD0/SI10 pin for serial interface data input, set PM11 to 1. The output latch of P11 at this time may be 0 or 1.

PM1 can be set by a 1-bit or 8-bit memory manipulation instruction.

Reset signal generation sets this register to FFH.

Figure 11-5. Format of Port Mode Register 1 (PM1)

Address: FF21H After reset: FFH R/W

Symbol	7	6	5	4	3	2	1	0
PM1	PM17	PM16	PM15	PM14	PM13	PM12	PM11	PM10
PM1n	P1n pin I/O mode selection (n = 0 to 7)							
0	Output mode (output buffer on)							
1	Input mode (output buffer off)							

11.4 Operation of Serial Interface UART0

Serial interface UART0 has the following two modes.

- Operation stop mode
- Asynchronous serial interface (UART) mode

11.4.1 Operation stop mode

In this mode, serial communication cannot be executed, thus reducing the power consumption. In addition, the pins can be used as ordinary port pins in this mode. To set the operation stop mode, clear bits 7, 6, and 5 (POWER0, TXE0, and RXE0) of ASIM0 to 0.

(1) Register used

The operation stop mode is set by asynchronous serial interface operation mode register 0 (ASIM0).

ASIM0 can be set by a 1-bit or 8-bit memory manipulation instruction.

Reset signal generation sets this register to 01H.

Address: FF70H After reset: 01H R/W

Symbol	<7>	<6>	<5>	4	3	2	1	0
ASIM0	POWER0	TXE0	RXE0	PS01	PS00	CL0	SL0	1

POWER0	Enables/disables operation of internal operation clock
0 ^{Note 1}	Disables operation of the internal operation clock (fixes the clock to low level) and asynchronously resets the internal circuit ^{Note 2} .

TXE0	Enables/disables transmission
0	Disables transmission (synchronously resets the transmission circuit).

RXE0	Enables/disables reception
0	Disables reception (synchronously resets the reception circuit).

- Notes**
1. The input from the RxD0 pin is fixed to high level when POWER0 = 0.
 2. Asynchronous serial interface reception error status register 0 (ASIS0), transmit shift register 0 (TXS0), and receive buffer register 0 (RXB0) are reset.

Caution Clear POWER0 to 0 after clearing TXE0 and RXE0 to 0 to set the operation stop mode. To start the communication, set POWER0 to 1, and then set TXE0 or RXE0 to 1.

Remark To use the RxD0/SI10/P11 and TxD0/SCK10/P10 pins as general-purpose port pins, see **CHAPTER 4 PORT FUNCTIONS**.

11.4.2 Asynchronous serial interface (UART) mode

In this mode, 1-byte data is transmitted/received following a start bit, and a full-duplex operation can be performed.

A dedicated UART baud rate generator is incorporated, so that communication can be executed at a wide range of baud rates.

(1) Registers used

- Asynchronous serial interface operation mode register 0 (ASIM0)
- Asynchronous serial interface reception error status register 0 (ASIS0)
- Baud rate generator control register 0 (BRGC0)
- Port mode register 1 (PM1)
- Port register 1 (P1)

The basic procedure of setting an operation in the UART mode is as follows.

- <1> Set the BRGC0 register (see **Figure 11-4**).
- <2> Set bits 1 to 4 (SL0, CL0, PS00, and PS01) of the ASIM0 register (see **Figure 11-2**).
- <3> Set bit 7 (POWER0) of the ASIM0 register to 1.
- <4> Set bit 6 (TXE0) of the ASIM0 register to 1. → Transmission is enabled.
Set bit 5 (RXE0) of the ASIM0 register to 1. → Reception is enabled.
- <5> Write data to the TXS0 register. → Data transmission is started.

Caution Take relationship with the other party of communication when setting the port mode register and port register.

The relationship between the register settings and pins is shown below.

Table 11-2. Relationship Between Register Settings and Pins

POWER0	TXE0	RXE0	PM10	P10	PM11	P11	UART0 Operation	Pin Function	
								TxD0/ $\overline{\text{SCK10}}$ /P10	RxD0/SI10/P11
0	0	0	×	×	×	×	Stop	$\overline{\text{SCK10}}$ /P10	SI10/P11
1	0	1	×	×	1	×	Reception	$\overline{\text{SCK10}}$ /P10	RxD0
	1	0	0	1	×	×	Transmission	TxD0	SI10/P11
	1	1	0	1	1	×	Transmission/ reception	TxD0	RxD0

Note Can be set as port function or serial interface CSI10.

Remark ×: don't care

POWER0: Bit 7 of asynchronous serial interface operation mode register 0 (ASIM0)

TXE0: Bit 6 of ASIM0

RXE0: Bit 5 of ASIM0

PM1×: Port mode register

P1×: Port output latch

(2) Communication operation

(a) Format and waveform example of normal transmit/receive data

Figures 11-6 and 11-7 show the format and waveform example of the normal transmit/receive data.

Figure 11-6. Format of Normal UART Transmit/Receive Data

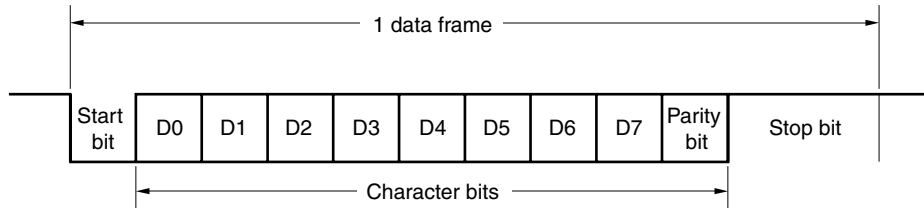

One data frame consists of the following bits.

- Start bit ... 1 bit
- Character bits ... 7 or 8 bits (LSB first)
- Parity bit ... Even parity, odd parity, 0 parity, or no parity
- Stop bit ... 1 or 2 bits

The character bit length, parity, and stop bit length in one data frame are specified by asynchronous serial interface operation mode register 0 (ASIM0).

Figure 11-7. Example of Normal UART Transmit/Receive Data Waveform

1. Data length: 8 bits, Parity: Even parity, Stop bit: 1 bit, Communication data: 55H

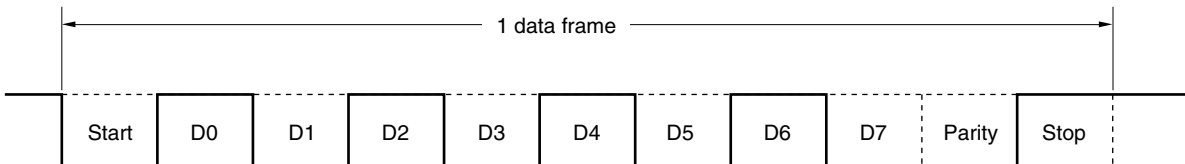

2. Data length: 7 bits, Parity: Odd parity, Stop bit: 2 bits, Communication data: 36H

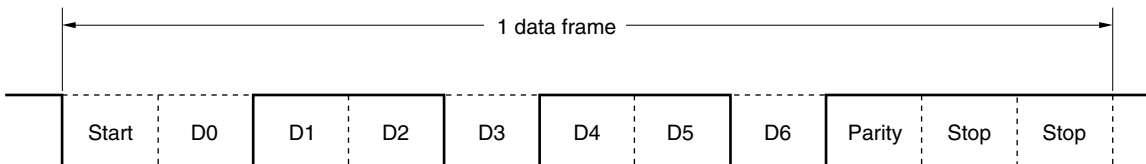

3. Data length: 8 bits, Parity: None, Stop bit: 1 bit, Communication data: 87H

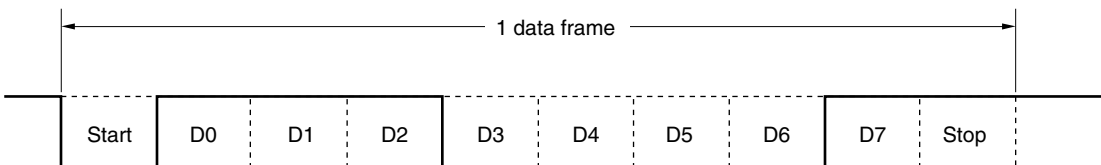

(b) Parity types and operation

The parity bit is used to detect a bit error in communication data. Usually, the same type of parity bit is used on both the transmission and reception sides. With even parity and odd parity, a 1-bit (odd number) error can be detected. With zero parity and no parity, an error cannot be detected.

(i) Even parity

- Transmission

Transmit data, including the parity bit, is controlled so that the number of bits that are “1” is even.

The value of the parity bit is as follows.

If transmit data has an odd number of bits that are “1”: 1

If transmit data has an even number of bits that are “1”: 0

- Reception

The number of bits that are “1” in the receive data, including the parity bit, is counted. If it is odd, a parity error occurs.

(ii) Odd parity

- Transmission

Unlike even parity, transmit data, including the parity bit, is controlled so that the number of bits that are “1” is odd.

If transmit data has an odd number of bits that are “1”: 0

If transmit data has an even number of bits that are “1”: 1

- Reception

The number of bits that are “1” in the receive data, including the parity bit, is counted. If it is even, a parity error occurs.

(iii) 0 parity

The parity bit is cleared to 0 when data is transmitted, regardless of the transmit data.

The parity bit is not detected when the data is received. Therefore, a parity error does not occur regardless of whether the parity bit is “0” or “1”.

(iv) No parity

No parity bit is appended to the transmit data.

Reception is performed assuming that there is no parity bit when data is received. Because there is no parity bit, a parity error does not occur.

(c) Transmission

If bit 7 (POWER0) of asynchronous serial interface operation mode register 0 (ASIM0) is set to 1 and bit 6 (TXE0) of ASIM0 is then set to 1, transmission is enabled. Transmission can be started by writing transmit data to transmit shift register 0 (TXS0). The start bit, parity bit, and stop bit are automatically appended to the data.

When transmission is started, the start bit is output from the TxD0 pin, and the transmit data is output followed by the rest of the data in order starting from the LSB. When transmission is completed, the parity and stop bits set by ASIM0 are appended and a transmission completion interrupt request (INTST0) is generated.

Transmission is stopped until the data to be transmitted next is written to TXS0.

Figure 11-8 shows the timing of the transmission completion interrupt request (INTST0). This interrupt occurs as soon as the last stop bit has been output.

Caution After transmit data is written to TXS0, do not write the next transmit data before the transmission completion interrupt signal (INTST0) is generated.

Figure 11-8. Transmission Completion Interrupt Request Timing

1. Stop bit length: 1

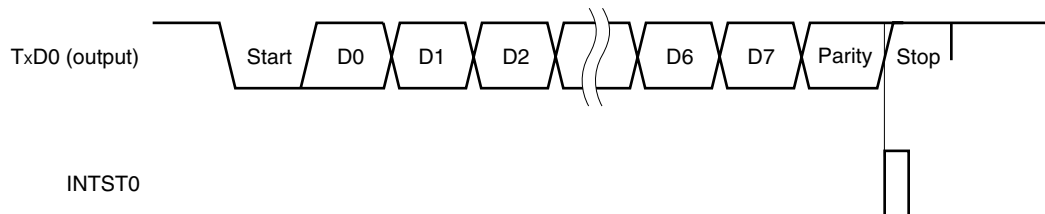

2. Stop bit length: 2

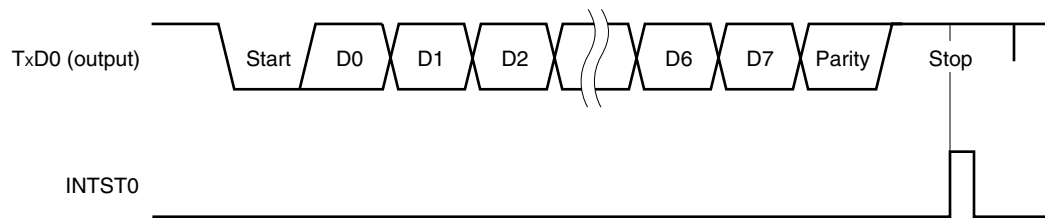

(d) Reception

Reception is enabled and the RxD0 pin input is sampled when bit 7 (POWER0) of asynchronous serial interface operation mode register 0 (ASIM0) is set to 1 and then bit 5 (RXE0) of ASIM0 is set to 1.

The 5-bit counter of the baud rate generator starts counting when the falling edge of the RxD0 pin input is detected. When the set value of baud rate generator control register 0 (BRGC0) has been counted, the RxD0 pin input is sampled again (▽ in Figure 11-9). If the RxD0 pin is low level at this time, it is recognized as a start bit.

When the start bit is detected, reception is started, and serial data is sequentially stored in receive shift register 0 (RXS0) at the set baud rate. When the stop bit has been received, the reception completion interrupt (INTSR0) is generated and the data of RXS0 is written to receive buffer register 0 (RXB0). If an overrun error (OVE0) occurs, however, the receive data is not written to RXB0.

Even if a parity error (PE0) occurs while reception is in progress, reception continues to the reception position of the stop bit, and an reception error interrupt (INTSR0) is generated after completion of reception. INTSR0 occurs upon completion of reception and in case of a reception error.

Figure 11-9. Reception Completion Interrupt Request Timing

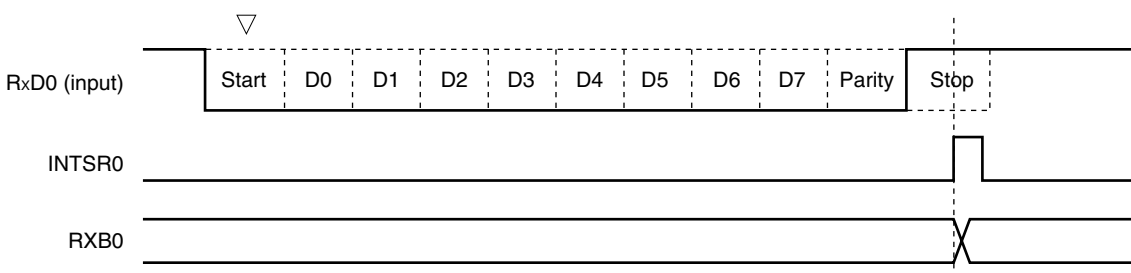

- Cautions**
1. If a reception error occurs, read asynchronous serial interface reception error status register 0 (ASIS0) and then read receive buffer register 0 (RXB0) to clear the error flag. Otherwise, an overrun error will occur when the next data is received, and the reception error status will persist.
 2. Reception is always performed with the “number of stop bits = 1”. The second stop bit is ignored.

(e) Reception error

Three types of errors may occur during reception: a parity error, framing error, or overrun error. If the error flag of asynchronous serial interface reception error status register 0 (ASIS0) is set as a result of data reception, a reception error interrupt (INTSR0) is generated.

Which error has occurred during reception can be identified by reading the contents of ASIS0 in the reception error interrupt (INTSR0) servicing (see **Figure 11-3**).

The contents of ASIS0 are cleared to 0 when ASIS0 is read.

Table 11-3. Cause of Reception Error

Reception Error	Cause
Parity error	The parity specified for transmission does not match the parity of the receive data.
Framing error	Stop bit is not detected.
Overrun error	Reception of the next data is completed before data is read from receive buffer register 0 (RXB0).

(f) Noise filter of receive data

The RxD0 signal is sampled using the base clock output by the prescaler block.

If two sampled values are the same, the output of the match detector changes, and the data is sampled as input data.

Because the circuit is configured as shown in Figure 11-10, the internal processing of the reception operation is delayed by two clocks from the external signal status.

Figure 11-10. Noise Filter Circuit

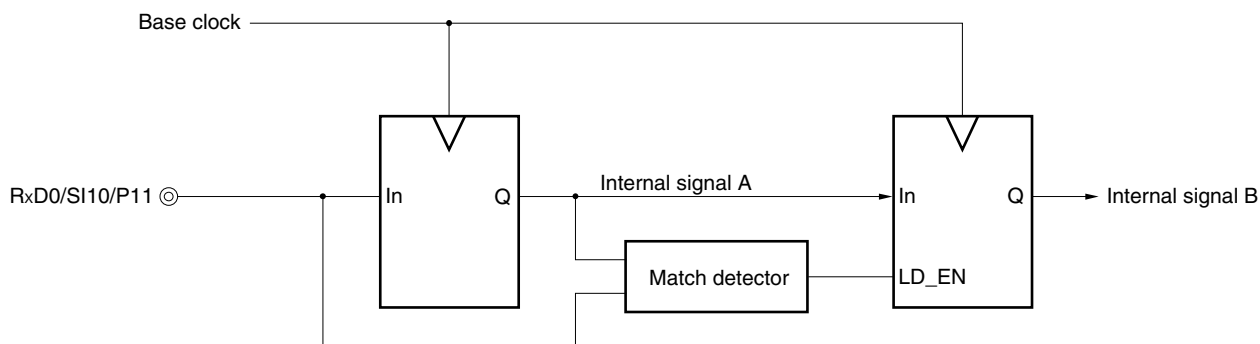

11.4.3 Dedicated baud rate generator

The dedicated baud rate generator consists of a source clock selector and a 5-bit programmable counter, and generates a serial clock for transmission/reception of UART0.

Separate 5-bit counters are provided for transmission and reception.

(1) Configuration of baud rate generator

- Base clock

The clock selected by bits 7 and 6 (TPS01 and TPS00) of baud rate generator control register 0 (BRGC0) is supplied to each module when bit 7 (POWER0) of asynchronous serial interface operation mode register 0 (ASIM0) is 1. This clock is called the base clock and its frequency is called f_{CLK0} . The base clock is fixed to low level when POWER0 = 0.

- Transmission counter

This counter stops operation, cleared to 0, when bit 7 (POWER0) or bit 6 (TXE0) of asynchronous serial interface operation mode register 0 (ASIM0) is 0.

It starts counting when POWER0 = 1 and TXE0 = 1.

The counter is cleared to 0 when the first data transmitted is written to transmit shift register 0 (TXS0).

- Reception counter

This counter stops operation, cleared to 0, when bit 7 (POWER0) or bit 5 (RXE0) of asynchronous serial interface operation mode register 0 (ASIM0) is 0.

It starts counting when the start bit has been detected.

The counter stops operation after one frame has been received, until the next start bit is detected.

Figure 11-11. Configuration of Baud Rate Generator

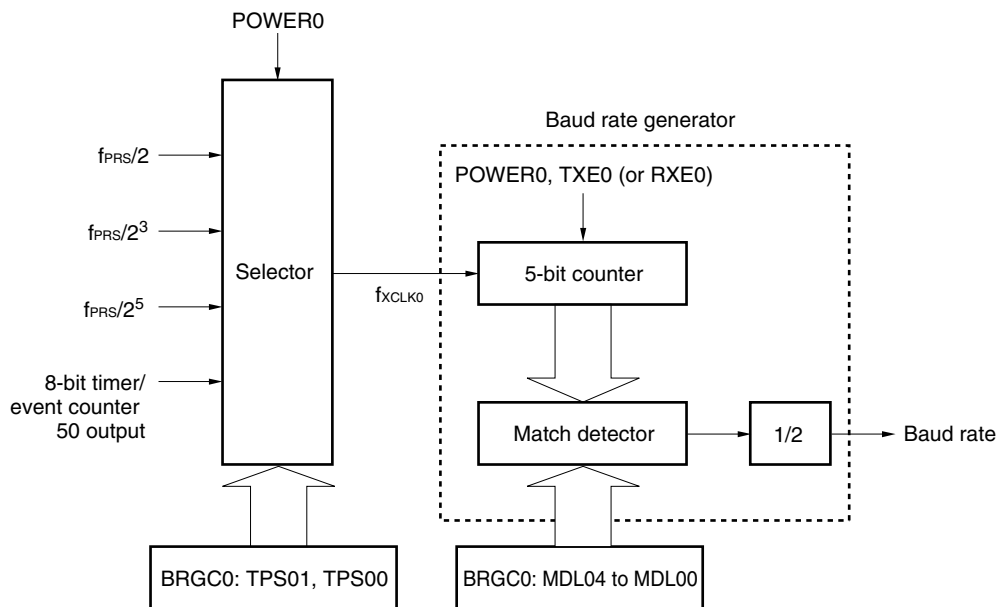

Remark $POWER0$: Bit 7 of asynchronous serial interface operation mode register 0 (ASIM0)
 $TXE0$: Bit 6 of ASIM0
 $RXE0$: Bit 5 of ASIM0
 $BRGC0$: Baud rate generator control register 0

(2) Generation of serial clock

A serial clock to be generated can be specified by using baud rate generator control register 0 (BRGC0).

Select the clock to be input to the 5-bit counter by using bits 7 and 6 (TPS01 and TPS00) of BRGC0.

Bits 4 to 0 (MDL04 to MDL00) of BRGC0 can be used to select the division value ($f_{XCLK0}/8$ to $f_{XCLK0}/31$) of the 5-bit counter.

11.4.4 Calculation of baud rate

(1) Baud rate calculation expression

The baud rate can be calculated by the following expression.

- Baud rate = $\frac{f_{CLK0}}{2 \times k}$ [bps]

f_{CLK0} : Frequency of base clock selected by the TPS01 and TPS00 bits of the BRGC0 register

k: Value set by the MDL04 to MDL00 bits of the BRGC0 register (k = 8, 9, 10, ..., 31)

Table 11-4. Set Value of TPS01 and TPS00

TPS01	TPS00	Base clock (f_{CLK0}) selection				
		$f_{PRS} = 2$ MHz	$f_{PRS} = 5$ MHz	$f_{PRS} = 10$ MHz	$f_{PRS} = 20$ MHz	
0	0	TM50 output				
0	1	$f_{PRS}/2$	1 MHz	2.5 MHz	5 MHz	10 MHz
1	0	$f_{PRS}/2^3$	250 kHz	625 kHz	1.25 MHz	2.5 MHz
1	1	$f_{PRS}/2^5$	62.5 kHz	156.25 kHz	312.5 kHz	625 kHz

(2) Error of baud rate

The baud rate error can be calculated by the following expression.

- Error (%) = $\left(\frac{\text{Actual baud rate (baud rate with error)}}{\text{Desired baud rate (correct baud rate)}} - 1 \right) \times 100$ [%]

Cautions 1. Keep the baud rate error during transmission to within the permissible error range at the reception destination.

2. Make sure that the baud rate error during reception satisfies the range shown in (4) Permissible baud rate range during reception.

Example: Frequency of base clock = 2.5 MHz = 2,500,000 Hz
 Set value of MDL04 to MDL00 bits of BRGC0 register = 10000B (k = 16)
 Target baud rate = 76,800 bps

$$\begin{aligned} \text{Baud rate} &= 2.5 \text{ M}/(2 \times 16) \\ &= 2,500,000/(2 \times 16) = 78,125 \text{ [bps]} \end{aligned}$$

$$\begin{aligned} \text{Error} &= (78,125/76,800 - 1) \times 100 \\ &= 1.725 \text{ [%]} \end{aligned}$$

(3) Example of setting baud rate

Table 11-5. Set Data of Baud Rate Generator

Baud Rate [bps]	$f_{PRS} = 2.0 \text{ MHz}$				$f_{PRS} = 5.0 \text{ MHz}$				$f_{PRS} = 10.0 \text{ MHz}$				$f_{PRS} = 20.0 \text{ MHz}$			
	TPS01, TPS00	k	Calculated Value	ERR [%]	TPS01, TPS00	k	Calculated Value	ERR [%]	TPS01, TPS00	k	Calculated Value	ERR [%]	TPS01, TPS00	k	Calculated Value	ERR [%]
4800	2	26	4808	0.16	3	16	4883	1.73	–	–	–	–	–	–	–	–
9600	2	13	9615	0.16	3	8	9766	1.73	3	16	9766	1.73	–	–	–	–
10400	2	12	10417	0.16	2	30	10417	0.16	3	15	10417	0.16	3	30	10417	0.16
19200	1	26	19231	0.16	2	16	19531	1.73	3	8	19531	1.73	3	16	19531	1.73
24000	1	21	23810	-0.79	2	13	24038	0.16	2	26	24038	0.16	3	13	24038	0.16
31250	1	16	31250	0	2	10	31250	0	2	20	31250	0	3	10	31250	0
33660	1	15	33333	-0.79	2	9	34722	3.34	2	18	34722	3.34	3	9	34722	3.34
38400	1	13	38462	0.16	2	8	39063	1.73	2	16	39063	1.73	3	8	39063	1.73
56000	1	9	55556	-0.79	1	22	56818	1.46	2	11	56818	1.46	2	22	56818	1.46
62500	1	8	62500	0	1	20	62500	0	2	10	62500	0	2	20	62500	0
76800	–	–	–	–	1	16	78125	1.73	2	8	78125	1.73	2	16	78125	1.73
115200	–	–	–	–	1	11	113636	-1.36	1	22	113636	-1.36	2	11	113636	-1.36
153600	–	–	–	–	1	8	156250	1.73	1	16	156250	1.73	2	8	156250	1.73
<R> 312500	–	–	–	–	–	–	–	–	1H	8	312500	0	1H	16	312500	0
<R> 625000	–	–	–	–	–	–	–	–	–	–	–	–	1H	8	625000	0

Remark TPS01, TPS00: Bits 7 and 6 of baud rate generator control register 0 (BRGC0) (setting of base clock (f_{XCLK0}))

k: Value set by the MDL04 to MDL00 bits of BRGC0 ($k = 8, 9, 10, \dots, 31$)

f_{PRS} : Peripheral hardware clock frequency

ERR: Baud rate error

(4) Permissible baud rate range during reception

The permissible error from the baud rate at the transmission destination during reception is shown below.

Caution Make sure that the baud rate error during reception is within the permissible error range, by using the calculation expression shown below.

Figure 11-12. Permissible Baud Rate Range During Reception

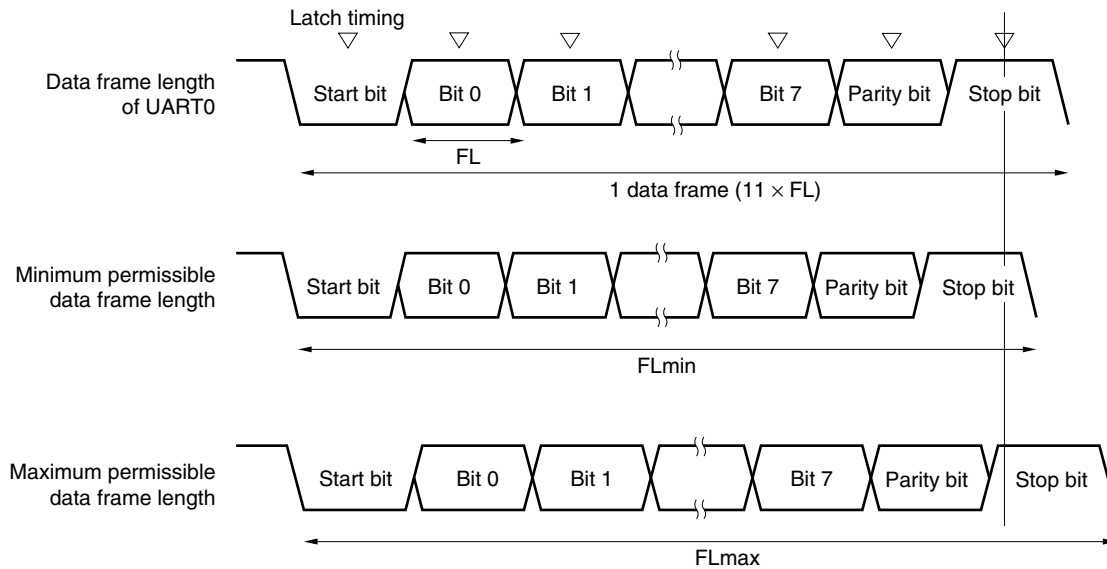

As shown in Figure 11-12, the latch timing of the receive data is determined by the counter set by baud rate generator control register 0 (BRGC0) after the start bit has been detected. If the last data (stop bit) meets this latch timing, the data can be correctly received.

Assuming that 11-bit data is received, the theoretical values can be calculated as follows.

$$FL = (\text{Brate})^{-1}$$

Brate: Baud rate of UART0

k: Set value of BRGC0

FL: 1-bit data length

Margin of latch timing: 2 clocks

$$\text{Minimum permissible data frame length: } FL_{\min} = 11 \times FL - \frac{k-2}{2k} \times FL = \frac{21k+2}{2k} FL$$

Therefore, the maximum receivable baud rate at the transmission destination is as follows.

$$BR_{\max} = (FL_{\min}/11)^{-1} = \frac{22k}{21k+2} \text{ Brate}$$

Similarly, the maximum permissible data frame length can be calculated as follows.

$$\frac{10}{11} \times FL_{\max} = 11 \times FL - \frac{k+2}{2 \times k} \times FL = \frac{21k-2}{2 \times k} FL$$

$$FL_{\max} = \frac{21k-2}{20k} FL \times 11$$

Therefore, the minimum receivable baud rate at the transmission destination is as follows.

$$BR_{\min} = (FL_{\max}/11)^{-1} = \frac{20k}{21k-2} \text{ Brate}$$

The permissible baud rate error between UART0 and the transmission destination can be calculated from the above minimum and maximum baud rate expressions, as follows.

Table 11-6. Maximum/Minimum Permissible Baud Rate Error

Division Ratio (k)	Maximum Permissible Baud Rate Error	Minimum Permissible Baud Rate Error
8	+3.53%	-3.61%
16	+4.14%	-4.19%
24	+4.34%	-4.38%
31	+4.44%	-4.47%

- Remarks**
1. The permissible error of reception depends on the number of bits in one frame, input clock frequency, and division ratio (k). The higher the input clock frequency and the higher the division ratio (k), the higher the permissible error.
 2. k: Set value of BRGCO

CHAPTER 12 SERIAL INTERFACE UART6

12.1 Functions of Serial Interface UART6

Serial interface UART6 has the following two modes.

(1) Operation stop mode

This mode is used when serial communication is not executed and can enable a reduction in the power consumption.

For details, see **12.4.1 Operation stop mode**.

(2) Asynchronous serial interface (UART) mode

This mode supports the LIN (Local Interconnect Network)-bus. The functions of this mode are outlined below.

For details, see **12.4.2 Asynchronous serial interface (UART) mode** and **12.4.3 Dedicated baud rate generator**.

- <R>
- Maximum transfer rate: 625 kbps
 - Two-pin configuration TxD6: Transmit data output pin
RxD6: Receive data input pin
 - Data length of communication data can be selected from 7 or 8 bits.
 - Dedicated internal 8-bit baud rate generator allowing any baud rate to be set
 - Transmission and reception can be performed independently (full duplex operation).
 - MSB- or LSB-first communication selectable
 - Inverted transmission operation
 - Sync break field transmission from 13 to 20 bits
 - More than 11 bits can be identified for sync break field reception (SBF reception flag provided).

- Cautions**
1. **The TxD6 output inversion function inverts only the transmission side and not the reception side. To use this function, the reception side must be ready for reception of inverted data.**
 2. **If clock supply to serial interface UART6 is not stopped (e.g., in the HALT mode), normal operation continues. If clock supply to serial interface UART6 is stopped (e.g., in the STOP mode), each register stops operating, and holds the value immediately before clock supply was stopped. The TxD6 pin also holds the value immediately before clock supply was stopped and outputs it. However, the operation is not guaranteed after clock supply is resumed. Therefore, reset the circuit so that POWER6 = 0, RXE6 = 0, and TXE6 = 0.**
 3. **Set POWER6 = 1 and then set TXE6 = 1 (transmission) or RXE6 = 1 (reception) to start communication.**
 4. **TXE6 and RXE6 are synchronized by the base clock (f_{XCLK6}) set by CKSR6. To enable transmission or reception again, set TXE6 or RXE6 to 1 at least two clocks of the base clock after TXE6 or RXE6 has been cleared to 0. If TXE6 or RXE6 is set within two clocks of the base clock, the transmission circuit or reception circuit may not be initialized.**
 5. **Set transmit data to TXB6 at least one base clock (f_{XCLK6}) after setting TXE6 = 1.**
 6. **If data is continuously transmitted, the communication timing from the stop bit to the next start bit is extended two operating clocks of the macro. However, this does not affect the result of communication because the reception side initializes the timing when it has detected a start bit. Do not use the continuous transmission function if the interface is used in LIN communication operation.**

Remark LIN stands for Local Interconnect Network and is a low-speed (1 to 20 kbps) serial communication protocol intended to aid the cost reduction of an automotive network.

LIN communication is single-master communication, and up to 15 slaves can be connected to one master.

The LIN slaves are used to control the switches, actuators, and sensors, and these are connected to the LIN master via the LIN network.

Normally, the LIN master is connected to a network such as CAN (Controller Area Network).

In addition, the LIN bus uses a single-wire method and is connected to the nodes via a transceiver that complies with ISO9141.

In the LIN protocol, the master transmits a frame with baud rate information and the slave receives it and corrects the baud rate error. Therefore, communication is possible when the baud rate error in the slave is $\pm 15\%$ or less.

Figures 12-1 and 12-2 outline the transmission and reception operations of LIN.

Figure 12-1. LIN Transmission Operation

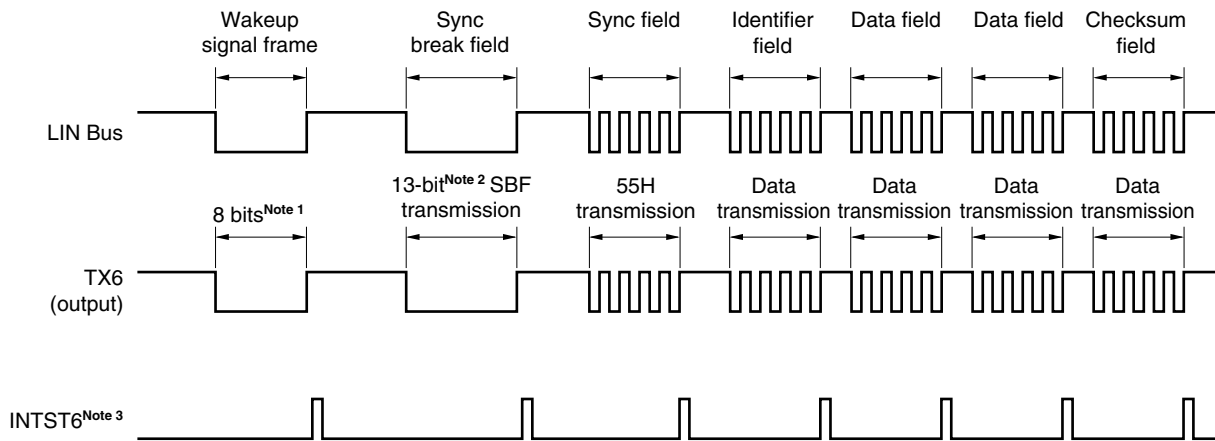

- Notes**
1. The wakeup signal frame is substituted by 80H transmission in the 8-bit mode.
 2. The sync break field is output by hardware. The output width is the bit length set by bits 4 to 2 (SBL62 to SBL60) of asynchronous serial interface control register 6 (ASICL6) (see **12.4.2 (2) (h) SBF transmission**).
 3. INTST6 is output on completion of each transmission. It is also output when SBF is transmitted.

Remark The interval between each field is controlled by software.

Figure 12-2. LIN Reception Operation

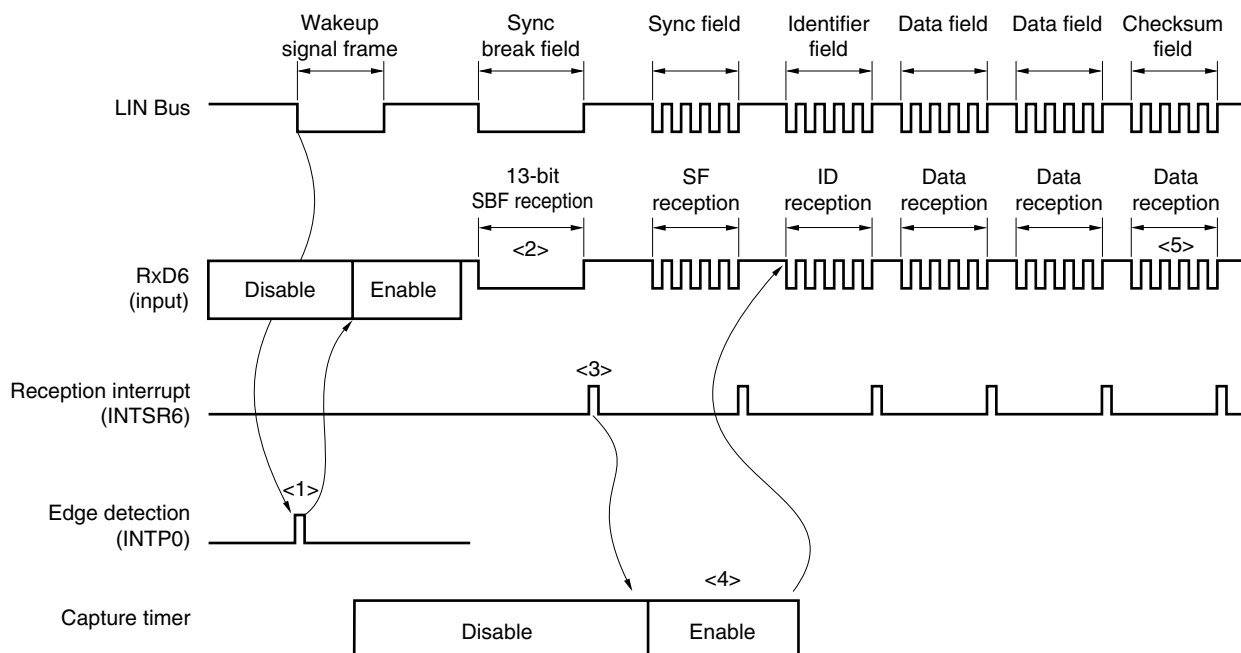

Reception processing is as follows.

- <1> The wakeup signal is detected at the edge of the pin, and enables UART6 and sets the SBF reception mode.
- <2> Reception continues until the STOP bit is detected. When an SBF with low-level data of 11 bits or more has been detected, it is assumed that SBF reception has been completed correctly, and an interrupt signal is output. If an SBF with low-level data of less than 11 bits has been detected, it is assumed that an SBF reception error has occurred. The interrupt signal is not output and the SBF reception mode is restored.
- <3> If SBF reception has been completed correctly, an interrupt signal is output. Start 16-bit timer/event counter 00 by the SBF reception end interrupt servicing and measure the bit interval (pulse width) of the sync field (see **6.4.8 Pulse width measurement operation**). Detection of errors OVE6, PE6, and FE6 is suppressed, and error detection processing of UART communication and data transfer of the shift register and RXB6 is not performed. The shift register holds the reset value FFH.
- <4> Calculate the baud rate error from the bit interval of the sync field, disable UART6 after SF reception, and then re-set baud rate generator control register 6 (BRGC6).
- <5> Distinguish the checksum field by software. Also perform processing by software to initialize UART6 after reception of the checksum field and to set the SBF reception mode again.

Figure 12-3 shows the port configuration for LIN reception operation.

The wakeup signal transmitted from the LIN master is received by detecting the edge of the external interrupt (INTP0). The length of the sync field transmitted from the LIN master can be measured using the external event capture operation of 16-bit timer/event counter 00, and the baud rate error can be calculated.

The input source of the reception port input (RxD6) can be input to the external interrupt (INTP0) and 16-bit timer/event counter 00 by port input switch control (ISC0/ISC1), without connecting RxD6 and INTP0/TI000 externally.

Figure 12-3. Port Configuration for LIN Reception Operation

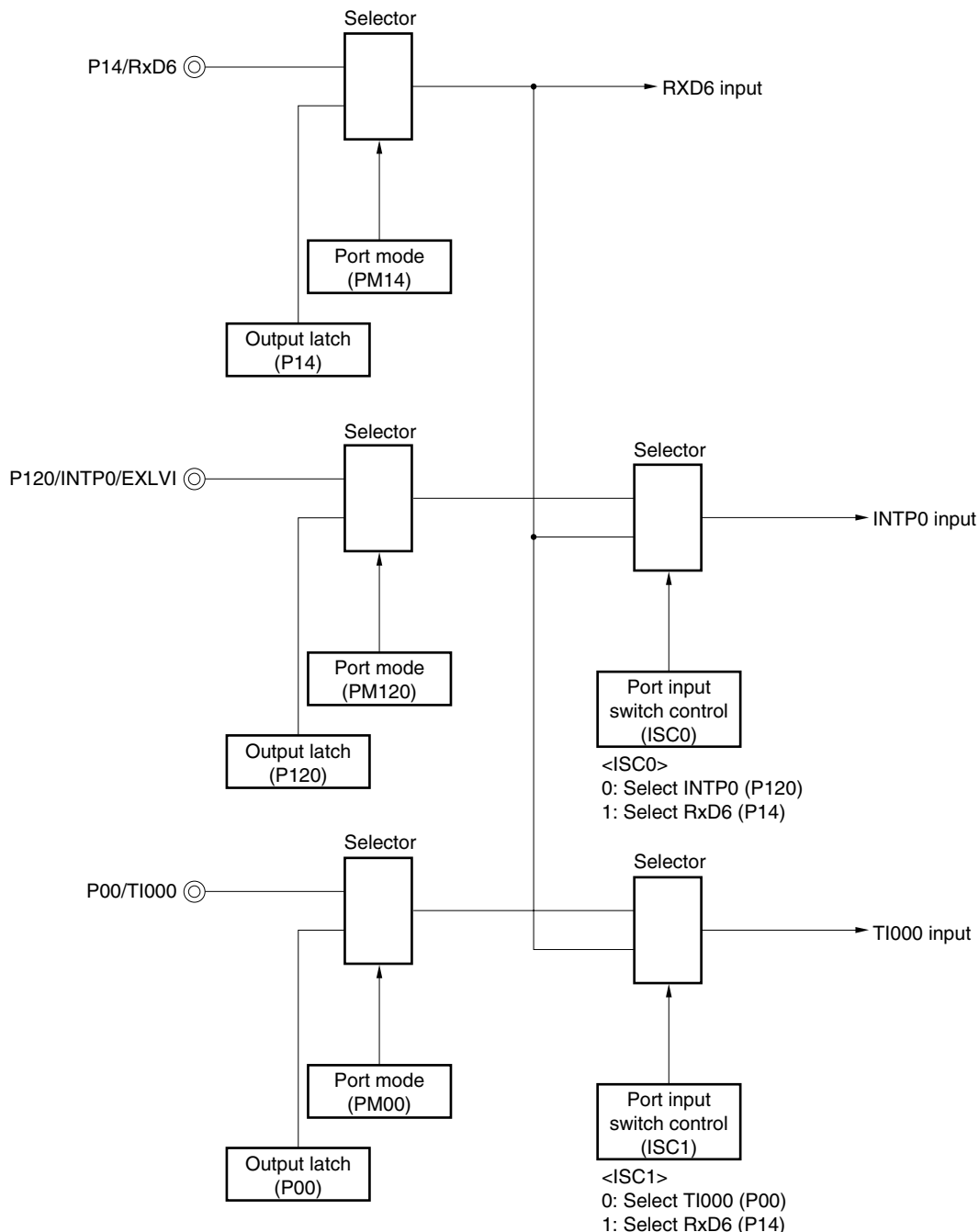

Remark ISC0, ISC1: Bits 0 and 1 of the input switch control register (ISC) (see **Figure 12-11**)

The peripheral functions used in the LIN communication operation are shown below.

<Peripheral functions used>

- External interrupt (INTP0); wakeup signal detection
Use: Detects the wakeup signal edges and detects start of communication.
- 16-bit timer/event counter 00 (TI000); baud rate error detection
Use: Detects the baud rate error (measures the TI000 input edge interval in the capture mode) by detecting the sync field (SF) length and divides it by the number of bits.
- Serial interface UART6

12.2 Configuration of Serial Interface UART6

Serial interface UART6 includes the following hardware.

Table 12-1. Configuration of Serial Interface UART6

Item	Configuration
Registers	Receive buffer register 6 (RXB6) Receive shift register 6 (RXS6) Transmit buffer register 6 (TXB6) Transmit shift register 6 (TXS6)
Control registers	Asynchronous serial interface operation mode register 6 (ASIM6) Asynchronous serial interface reception error status register 6 (ASIS6) Asynchronous serial interface transmission status register 6 (ASIF6) Clock selection register 6 (CKSR6) Baud rate generator control register 6 (BRGC6) Asynchronous serial interface control register 6 (ASICL6) Input switch control register (ISC) Port mode register 1 (PM1) Port register 1 (P1)

Figure 12-4. Block Diagram of Serial Interface UART6

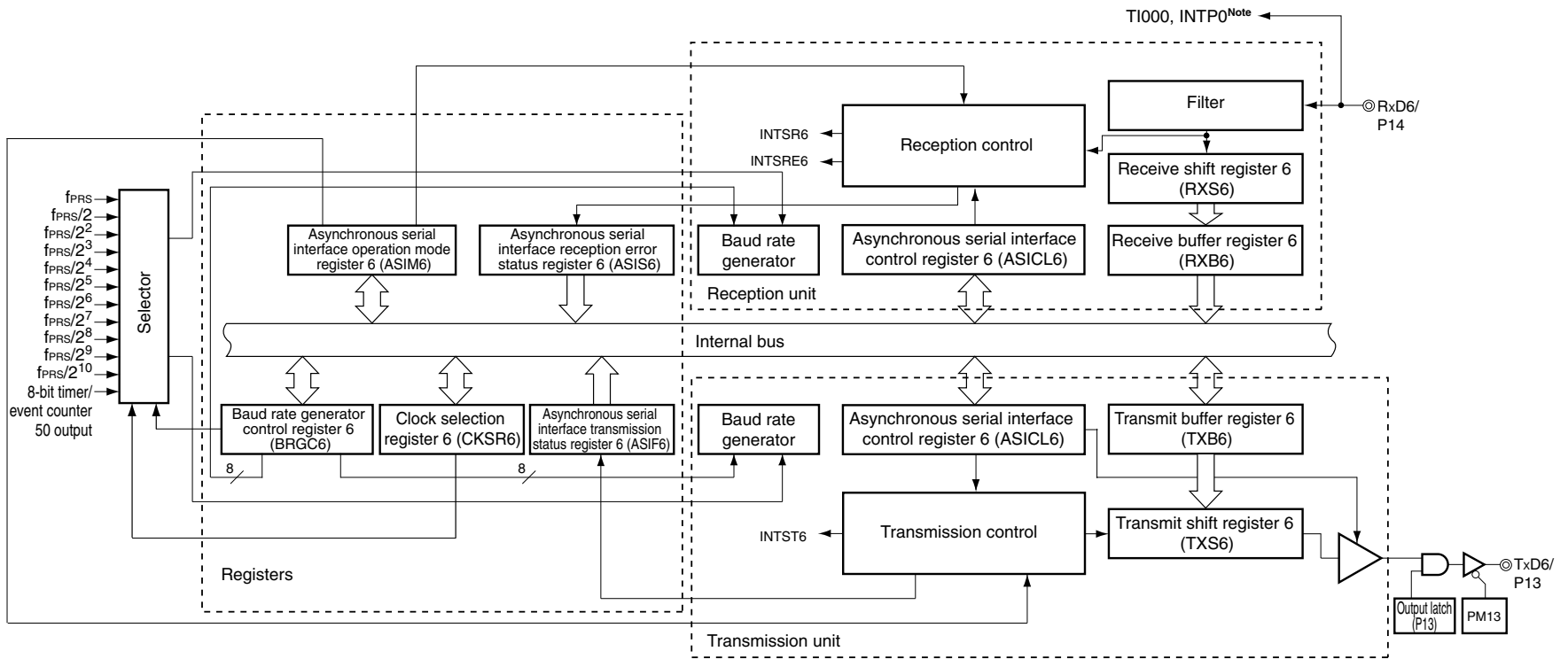

Note Selectable with input switch control register (ISC).

(1) Receive buffer register 6 (RXB6)

This 8-bit register stores parallel data converted by receive shift register 6 (RXS6).

Each time 1 byte of data has been received, new receive data is transferred to this register from RXS6. If the data length is set to 7 bits, data is transferred as follows.

- In LSB-first reception, the receive data is transferred to bits 0 to 6 of RXB6 and the MSB of RXB6 is always 0.
- In MSB-first reception, the receive data is transferred to bits 1 to 7 of RXB6 and the LSB of RXB6 is always 0.

If an overrun error (OVE6) occurs, the receive data is not transferred to RXB6.

RXB6 can be read by an 8-bit memory manipulation instruction. No data can be written to this register.

Reset signal generation sets this register to FFH.

(2) Receive shift register 6 (RXS6)

This register converts the serial data input to the RxD6 pin into parallel data.

RXS6 cannot be directly manipulated by a program.

(3) Transmit buffer register 6 (TXB6)

This buffer register is used to set transmit data. Transmission is started when data is written to TXB6.

This register can be read or written by an 8-bit memory manipulation instruction.

Reset signal generation sets this register to FFH.

Cautions 1. Do not write data to TXB6 when bit 1 (TXBF6) of asynchronous serial interface transmission status register 6 (ASIF6) is 1.

2. Do not refresh (write the same value to) TXB6 by software during a communication operation (when bits 7 and 6 (POWER6, TXE6) of asynchronous serial interface operation mode register 6 (ASIM6) are 1 or when bits 7 and 5 (POWER6, RXE6) of ASIM6 are 1).

3. Set transmit data to TXB6 at least one base clock (f_{CLK6}) after setting TXE6 = 1.

(4) Transmit shift register 6 (TXS6)

This register transmits the data transferred from TXB6 from the TxD6 pin as serial data. Data is transferred from TXB6 immediately after TXB6 is written for the first transmission, or immediately before INTST6 occurs after one frame was transmitted for continuous transmission. Data is transferred from TXB6 and transmitted from the TxD6 pin at the falling edge of the base clock.

TXS6 cannot be directly manipulated by a program.

12.3 Registers Controlling Serial Interface UART6

Serial interface UART6 is controlled by the following nine registers.

- Asynchronous serial interface operation mode register 6 (ASIM6)
- Asynchronous serial interface reception error status register 6 (ASIS6)
- Asynchronous serial interface transmission status register 6 (ASIF6)
- Clock selection register 6 (CKSR6)
- Baud rate generator control register 6 (BRGC6)
- Asynchronous serial interface control register 6 (ASICL6)
- Input switch control register (ISC)
- Port mode register 1 (PM1)
- Port register 1 (P1)

(1) Asynchronous serial interface operation mode register 6 (ASIM6)

This 8-bit register controls the serial communication operations of serial interface UART6.

This register can be set by a 1-bit or 8-bit memory manipulation instruction.

Reset signal generation sets this register to 01H.

Remark ASIM6 can be refreshed (the same value is written) by software during a communication operation (when bits 7 and 6 (POWER6, TXE6) of ASIM6 = 1 or bits 7 and 5 (POWER6, RXE6) of ASIM6 = 1).

Figure 12-5. Format of Asynchronous Serial Interface Operation Mode Register 6 (ASIM6) (1/2)

Address: FF50H After reset: 01H R/W

Symbol	<7>	<6>	<5>	4	3	2	1	0
ASIM6	POWER6	TXE6	RXE6	PS61	PS60	CL6	SL6	ISRM6
POWER6	Enables/disables operation of internal operation clock							
0 ^{Note 1}	Disables operation of the internal operation clock (fixes the clock to low level) and asynchronously resets the internal circuit ^{Note 2} .							
1	Enables operation of the internal operation clock							
TXE6	Enables/disables transmission							
0	Disables transmission (synchronously resets the transmission circuit).							
1	Enables transmission							
RXE6	Enables/disables reception							
0	Disables reception (synchronously resets the reception circuit).							
1	Enables reception							

- Notes**
1. The output of the TxD6 pin goes high level and the input from the RxD6 pin is fixed to the high level when POWER6 = 0 during transmission.
 2. Asynchronous serial interface reception error status register 6 (ASIS6), asynchronous serial interface transmission status register 6 (ASIF6), bit 7 (SBRF6) and bit 6 (SBRT6) of asynchronous serial interface control register 6 (ASICL6), and receive buffer register 6 (RXB6) are reset.

Figure 12-5. Format of Asynchronous Serial Interface Operation Mode Register 6 (ASIM6) (2/2)

PS61	PS60	Transmission operation	Reception operation
0	0	Does not output parity bit.	Reception without parity
0	1	Outputs 0 parity.	Reception as 0 parity ^{Note}
1	0	Outputs odd parity.	Judges as odd parity.
1	1	Outputs even parity.	Judges as even parity.

CL6	Specifies character length of transmit/receive data
0	Character length of data = 7 bits
1	Character length of data = 8 bits

SL6	Specifies number of stop bits of transmit data
0	Number of stop bits = 1
1	Number of stop bits = 2

ISRM6	Enables/disables occurrence of reception completion interrupt in case of error
0	“INTSRE6” occurs in case of error (at this time, INTSR6 does not occur).
1	“INTSR6” occurs in case of error (at this time, INTSRE6 does not occur).

Note If “reception as 0 parity” is selected, the parity is not judged. Therefore, bit 2 (PE6) of asynchronous serial interface reception error status register 6 (ASIS6) is not set and the error interrupt does not occur.

- Cautions**
1. To start the transmission, set POWER6 to 1 and then set TXE6 to 1. To stop the transmission, clear TXE6 to 0, and then clear POWER6 to 0.
 2. To start the reception, set POWER6 to 1 and then set RXE6 to 1. To stop the reception, clear RXE6 to 0, and then clear POWER6 to 0.
 3. Set POWER6 to 1 and then set RXE6 to 1 while a high level is input to the RxD6 pin. If POWER6 is set to 1 and RXE6 is set to 1 while a low level is input, reception is started.
 4. TXE6 and RXE6 are synchronized by the base clock (f_{CLK6}) set by CKSR6. To enable transmission or reception again, set TXE6 or RXE6 to 1 at least two clocks of the base clock after TXE6 or RXE6 has been cleared to 0. If TXE6 or RXE6 is set within two clocks of the base clock, the transmission circuit or reception circuit may not be initialized.
 5. Set transmit data to TXB6 at least one base clock (f_{CLK6}) after setting TXE6 = 1.
 6. Clear the TXE6 and RXE6 bits to 0 before rewriting the PS61, PS60, and CL6 bits.
 7. Fix the PS61 and PS60 bits to 0 when used in LIN communication operation.
 8. Clear TXE6 to 0 before rewriting the SL6 bit. Reception is always performed with “the number of stop bits = 1”, and therefore, is not affected by the set value of the SL6 bit.
 9. Make sure that RXE6 = 0 when rewriting the ISRM6 bit.

(2) Asynchronous serial interface reception error status register 6 (ASIS6)

This register indicates an error status on completion of reception by serial interface UART6. It includes three error flag bits (PE6, FE6, OVE6).

This register is read-only by an 8-bit memory manipulation instruction.

Reset signal generation, or clearing bit 7 (POWER6) or bit 5 (RXE6) of ASIM6 to 0 clears this register to 00H. 00H is read when this register is read. If a reception error occurs, read ASIS6 and then read receive buffer register 6 (RXB6) to clear the error flag.

Figure 12-6. Format of Asynchronous Serial Interface Reception Error Status Register 6 (ASIS6)

Address: FF53H After reset: 00H R

Symbol	7	6	5	4	3	2	1	0
ASIS6	0	0	0	0	0	PE6	FE6	OVE6

PE6	Status flag indicating parity error
0	If POWER6 = 0 or RXE6 = 0, or if ASIS6 register is read
1	If the parity of transmit data does not match the parity bit on completion of reception

FE6	Status flag indicating framing error
0	If POWER6 = 0 or RXE6 = 0, or if ASIS6 register is read
1	If the stop bit is not detected on completion of reception

OVE6	Status flag indicating overrun error
0	If POWER6 = 0 or RXE6 = 0, or if ASIS6 register is read
1	If receive data is set to the RXB6 register and the next reception operation is completed before the data is read.

- Cautions**
1. The operation of the PE6 bit differs depending on the set values of the PS61 and PS60 bits of asynchronous serial interface operation mode register 6 (ASIM6).
 2. For the stop bit of the receive data, only the first stop bit is checked regardless of the number of stop bits.
 3. If an overrun error occurs, the next receive data is not written to receive buffer register 6 (RXB6) but discarded.
 4. If data is read from ASIS6, a wait cycle is generated. Do not read data from ASIS6 when the CPU is operating on the subsystem clock and the peripheral hardware clock is stopped. For details, see CHAPTER 28 CAUTIONS FOR WAIT.

(3) Asynchronous serial interface transmission status register 6 (ASIF6)

This register indicates the status of transmission by serial interface UART6. It includes two status flag bits (TXBF6 and TXSF6).

Transmission can be continued without disruption even during an interrupt period, by writing the next data to the TXB6 register after data has been transferred from the TXB6 register to the TXS6 register.

This register is read-only by an 8-bit memory manipulation instruction.

Reset signal generation, or clearing bit 7 (POWER6) or bit 6 (TXE6) of ASIM6 to 0 clears this register to 00H.

Figure 12-7. Format of Asynchronous Serial Interface Transmission Status Register 6 (ASIF6)

Address: FF55H After reset: 00H R

Symbol	7	6	5	4	3	2	1	0
ASIF6	0	0	0	0	0	0	TXBF6	TXSF6

TXBF6	Transmit buffer data flag
0	If POWER6 = 0 or TXE6 = 0, or if data is transferred to transmit shift register 6 (TXS6)
1	If data is written to transmit buffer register 6 (TXB6) (if data exists in TXB6)

TXSF6	Transmit shift register data flag
0	If POWER6 = 0 or TXE6 = 0, or if the next data is not transferred from transmit buffer register 6 (TXB6) after completion of transfer
1	If data is transferred from transmit buffer register 6 (TXB6) (if data transmission is in progress)

- Cautions**
- 1. To transmit data continuously, write the first transmit data (first byte) to the TXB6 register. Be sure to check that the TXBF6 flag is “0”. If so, write the next transmit data (second byte) to the TXB6 register. If data is written to the TXB6 register while the TXBF6 flag is “1”, the transmit data cannot be guaranteed.**
 - 2. To initialize the transmission unit upon completion of continuous transmission, be sure to check that the TXSF6 flag is “0” after generation of the transmission completion interrupt, and then execute initialization. If initialization is executed while the TXSF6 flag is “1”, the transmit data cannot be guaranteed.**

(4) Clock selection register 6 (CKSR6)

This register selects the base clock of serial interface UART6.
 CKSR6 can be set by an 8-bit memory manipulation instruction.
 Reset signal generation sets this register to 00H.

Remark CKSR6 can be refreshed (the same value is written) by software during a communication operation (when bits 7 and 6 (POWER6, TXE6) of ASIM6 = 1 or bits 7 and 5 (POWER6, RXE6) of ASIM6 = 1).

Figure 12-8. Format of Clock Selection Register 6 (CKSR6)

Address: FF56H After reset: 00H R/W

Symbol	7	6	5	4	3	2	1	0
CKSR6	0	0	0	0	TPS63	TPS62	TPS61	TPS60

TPS63	TPS62	TPS61	TPS60		Base clock (f _{CLK6}) selection			
					f _{PRS} = 2 MHz	f _{PRS} = 5 MHz	f _{PRS} = 10 MHz	f _{PRS} = 20 MHz
0	0	0	0	f _{PRS}	2 MHz	5 MHz	10 MHz	20 MHz
0	0	0	1	f _{PRS} /2	1 MHz	2.5 MHz	5 MHz	10 MHz
0	0	1	0	f _{PRS} /2 ²	500 kHz	1.25 MHz	2.5 MHz	5 MHz
0	0	1	1	f _{PRS} /2 ³	250 kHz	625 kHz	1.25 MHz	2.5 MHz
0	1	0	0	f _{PRS} /2 ⁴	125 kHz	312.5 kHz	625 kHz	1.25 MHz
0	1	0	1	f _{PRS} /2 ⁵	62.5 kHz	156.25 kHz	312.5 kHz	625 kHz
0	1	1	0	f _{PRS} /2 ⁶	31.25 kHz	78.13 kHz	156.25 kHz	312.5 kHz
0	1	1	1	f _{PRS} /2 ⁷	15.625 kHz	39.06 kHz	78.13 kHz	156.25 kHz
1	0	0	0	f _{PRS} /2 ⁸	7.813 kHz	19.53 kHz	39.06 kHz	78.13 kHz
1	0	0	1	f _{PRS} /2 ⁹	3.906 kHz	9.77 kHz	19.53 kHz	39.06 kHz
1	0	1	0	f _{PRS} /2 ¹⁰	1.953 kHz	4.88 kHz	9.77 kHz	19.53 kHz
1	0	1	1	TM50 output ^{Note}				
Other than above				Setting prohibited				

Note Note the following points when selecting the TM50 output as the base clock.

- Mode in which the count clock is cleared and started upon a match of TM50 and CR50 (TMC506 = 0)
 Start the operation of 8-bit timer/event counter 50 first and then enable the timer F/F inversion operation (TMC501 = 1).
- PWM mode (TMC506 = 1)
 Start the operation of 8-bit timer/event counter 50 first and then set the count clock to make the duty = 50%.

It is not necessary to enable the TO50 pin as a timer output pin in any mode.

Caution Make sure POWER6 = 0 when rewriting TPS63 to TPS60.

Remarks

1. f_{PRS}: Peripheral hardware clock frequency
2. TMC506: Bit 6 of 8-bit timer mode control register 50 (TMC50)
 TMC501: Bit 1 of TMC50

(5) Baud rate generator control register 6 (BRGC6)

This register sets the division value of the 8-bit counter of serial interface UART6.

BRGC6 can be set by an 8-bit memory manipulation instruction.

Reset signal generation sets this register to FFH.

Remark BRGC6 can be refreshed (the same value is written) by software during a communication operation (when bits 7 and 6 (POWER6, TXE6) of ASIM6 = 1 or bits 7 and 5 (POWER6, RXE6) of ASIM6 = 1).

Figure 12-9. Format of Baud Rate Generator Control Register 6 (BRGC6)

Address: FF57H After reset: FFH R/W

Symbol	7	6	5	4	3	2	1	0
BRGC6	MDL67	MDL66	MDL65	MDL64	MDL63	MDL62	MDL61	MDL60

	MDL67	MDL66	MDL65	MDL64	MDL63	MDL62	MDL61	MDL60	k	Output clock selection of 8-bit counter
<R>	0	0	0	0	0	0	×	×	×	Setting prohibited
<R>	0	0	0	0	0	1	0	0	4	$f_{XCLK6}/4$
<R>	0	0	0	0	0	1	0	1	5	$f_{XCLK6}/5$
<R>	0	0	0	0	0	1	1	0	6	$f_{XCLK6}/6$
	•	•	•	•	•	•	•	•	•	•
	•	•	•	•	•	•	•	•	•	•
	•	•	•	•	•	•	•	•	•	•
	•	•	•	•	•	•	•	•	•	•
	•	•	•	•	•	•	•	•	•	•
	1	1	1	1	1	1	0	0	252	$f_{XCLK6}/252$
	1	1	1	1	1	1	0	1	253	$f_{XCLK6}/253$
	1	1	1	1	1	1	1	0	254	$f_{XCLK6}/254$
	1	1	1	1	1	1	1	1	255	$f_{XCLK6}/255$

Cautions 1. Make sure that bit 6 (TXE6) and bit 5 (RXE6) of the ASIM6 register = 0 when rewriting the MDL67 to MDL60 bits.

2. The baud rate is the output clock of the 8-bit counter divided by 2.

Remarks 1. f_{XCLK6} : Frequency of base clock selected by the TPS63 to TPS60 bits of CKSR6 register

2. k: Value set by MDL67 to MDL60 bits (k = 4, 5, 6, ..., 255)

3. ×: Don't care

(6) Asynchronous serial interface control register 6 (ASICL6)

This register controls the serial communication operations of serial interface UART6.

ASICL6 can be set by a 1-bit or 8-bit memory manipulation instruction.

Reset signal generation sets this register to 16H.

Caution ASICL6 can be refreshed (the same value is written) by software during a communication operation (when bits 7 and 6 (POWER6, TXE6) of ASIM6 = 1 or bits 7 and 5 (POWER6, RXE6) of ASIM6 = 1). However, do not set both SBRT6 and SBTT6 to 1 by a refresh operation during SBF reception (SBRT6 = 1) or SBF transmission (until INTST6 occurs since SBTT6 has been set (1)), because it may re-trigger SBF reception or SBF transmission.

Figure 12-10. Format of Asynchronous Serial Interface Control Register 6 (ASICL6) (1/2)

Address: FF58H After reset: 16H R/W^{Note}

Symbol	<7>	<6>	5	4	3	2	1	0
ASICL6	SBRF6	SBRT6	SBTT6	SBL62	SBL61	SBL60	DIR6	TXDLV6

SBRF6	SBF reception status flag
0	If POWER6 = 0 and RXE6 = 0 or if SBF reception has been completed correctly
1	SBF reception in progress

SBRT6	SBF reception trigger
0	–
1	SBF reception trigger

SBTT6	SBF transmission trigger
0	–
1	SBF transmission trigger

Note Bit 7 is read-only.

Figure 12-10. Format of Asynchronous Serial Interface Control Register 6 (ASICL6) (2/2)

SBL62	SBL61	SBL60	SBF transmission output width control
1	0	1	SBF is output with 13-bit length.
1	1	0	SBF is output with 14-bit length.
1	1	1	SBF is output with 15-bit length.
0	0	0	SBF is output with 16-bit length.
0	0	1	SBF is output with 17-bit length.
0	1	0	SBF is output with 18-bit length.
0	1	1	SBF is output with 19-bit length.
1	0	0	SBF is output with 20-bit length.

DIR6	First-bit specification
0	MSB
1	LSB

TXDLV6	Enables/disables inverting TxD6 output
0	Normal output of TxD6
1	Inverted output of TxD6

- Cautions**
1. In the case of an SBF reception error, the mode returns to the SBF reception mode. The status of the SBRF6 flag is held (1).
 2. Before setting the SBRT6 bit, make sure that bit 7 (POWER6) and bit 5 (RXE6) of ASIM6 = 1. After setting the SBRT6 bit to 1, do not clear it to 0 before SBF reception is completed (before an interrupt request signal is generated).
 3. The read value of the SBRT6 bit is always 0. SBRT6 is automatically cleared to 0 after SBF reception has been correctly completed.
 4. Before setting the SBTT6 bit to 1, make sure that bit 7 (POWER6) and bit 6 (TXE6) of ASIM6 = 1. After setting the SBTT6 bit to 1, do not clear it to 0 before SBF transmission is completed (before an interrupt request signal is generated).
 5. The read value of the SBTT6 bit is always 0. SBTT6 is automatically cleared to 0 at the end of SBF transmission.
 6. Do not set the SBRT6 bit to 1 during reception, and do not set the SBTT6 bit to 1 during transmission.
 7. Before rewriting the DIR6 and TXDLV6 bits, clear the TXE6 and RXE6 bits to 0.

(7) Input switch control register (ISC)

The input switch control register (ISC) is used to receive a status signal transmitted from the master during LIN (Local Interconnect Network) reception.

The signal input from the P14/RxD6 pin is selected as the input source of INTPO and TI000 when ISC0 and ISC1 are set to 1.

This register can be set by a 1-bit or 8-bit memory manipulation instruction.

Reset signal generation sets this register to 00H.

Figure 12-11. Format of Input Switch Control Register (ISC)

Address: FF4FH After reset: 00H R/W

Symbol	7	6	5	4	3	2	1	0
ISC	0	0	0	0	0	0	ISC1	ISC0

ISC1	TI000 input source selection
0	TI000 (P00)
1	RxD6 (P14)

ISC0	INTPO input source selection
0	INTPO (P120)
1	RxD6 (P14)

(8) Port mode register 1 (PM1)

This register sets port 1 input/output in 1-bit units.

When using the P13/TxD6 pin for serial interface data output, clear PM13 to 0 and set the output latch of P13 to 1.

When using the P14/RxD6 pin for serial interface data input, set PM14 to 1. The output latch of P14 at this time may be 0 or 1.

PM1 can be set by a 1-bit or 8-bit memory manipulation instruction.

Reset signal generation sets this register to FFH.

Figure 12-12. Format of Port Mode Register 1 (PM1)

Address: FF21H After reset: FFH R/W

Symbol	7	6	5	4	3	2	1	0
PM1	PM17	PM16	PM15	PM14	PM13	PM12	PM11	PM10

PM1n	P1n pin I/O mode selection (n = 0 to 7)
0	Output mode (output buffer on)
1	Input mode (output buffer off)

12.4 Operation of Serial Interface UART6

Serial interface UART6 has the following two modes.

- Operation stop mode
- Asynchronous serial interface (UART) mode

12.4.1 Operation stop mode

In this mode, serial communication cannot be executed; therefore, the power consumption can be reduced. In addition, the pins can be used as ordinary port pins in this mode. To set the operation stop mode, clear bits 7, 6, and 5 (POWER6, TXE6, and RXE6) of ASIM6 to 0.

(1) Register used

The operation stop mode is set by asynchronous serial interface operation mode register 6 (ASIM6).

ASIM6 can be set by a 1-bit or 8-bit memory manipulation instruction.

Reset signal generation sets this register to 01H.

Address: FF50H After reset: 01H R/W

Symbol	<7>	<6>	<5>	4	3	2	1	0
ASIM6	POWER6	TXE6	RXE6	PS61	PS60	CL6	SL6	ISRM6
POWER6	Enables/disables operation of internal operation clock							
0 ^{Note 1}	Disables operation of the internal operation clock (fixes the clock to low level) and asynchronously resets the internal circuit ^{Note 2} .							
TXE6	Enables/disables transmission							
0	Disables transmission operation (synchronously resets the transmission circuit).							
RXE6	Enables/disables reception							
0	Disables reception (synchronously resets the reception circuit).							

- Notes**
1. The output of the TxD6 pin goes high and the input from the RxD6 pin is fixed to high level when POWER6 = 0 during transmission.
 2. Asynchronous serial interface reception error status register 6 (ASIS6), asynchronous serial interface transmission status register 6 (ASIF6), bit 7 (SBRF6) and bit 6 (SBRT6) of asynchronous serial interface control register 6 (ASICL6), and receive buffer register 6 (RXB6) are reset.

Caution Clear POWER6 to 0 after clearing TXE6 and RXE6 to 0 to stop the operation.
To start the communication, set POWER6 to 1, and then set TXE6 or RXE6 to 1.

Remark To use the RxD6/P14 and TxD6/P13 pins as general-purpose port pins, see **CHAPTER 4 PORT FUNCTIONS**.

12.4.2 Asynchronous serial interface (UART) mode

In this mode, data of 1 byte is transmitted/received following a start bit, and a full-duplex operation can be performed.

A dedicated UART baud rate generator is incorporated, so that communication can be executed at a wide range of baud rates.

(1) Registers used

- Asynchronous serial interface operation mode register 6 (ASIM6)
- Asynchronous serial interface reception error status register 6 (ASIS6)
- Asynchronous serial interface transmission status register 6 (ASIF6)
- Clock selection register 6 (CKSR6)
- Baud rate generator control register 6 (BRGC6)
- Asynchronous serial interface control register 6 (ASICL6)
- Input switch control register (ISC)
- Port mode register 1 (PM1)
- Port register 1 (P1)

The basic procedure of setting an operation in the UART mode is as follows.

- <1> Set the CKSR6 register (see **Figure 12-8**).
- <2> Set the BRGC6 register (see **Figure 12-9**).
- <3> Set bits 0 to 4 (ISRM6, SL6, CL6, PS60, PS61) of the ASIM6 register (see **Figure 12-5**).
- <4> Set bits 0 and 1 (TXDLV6, DIR6) of the ASICL6 register (see **Figure 12-10**).
- <5> Set bit 7 (POWER6) of the ASIM6 register to 1.
- <6> Set bit 6 (TXE6) of the ASIM6 register to 1. → Transmission is enabled.
Set bit 5 (RXE6) of the ASIM6 register to 1. → Reception is enabled.
- <7> Write data to transmit buffer register 6 (TXB6). → Data transmission is started.

Caution Take relationship with the other party of communication when setting the port mode register and port register.

The relationship between the register settings and pins is shown below.

Table 12-2. Relationship Between Register Settings and Pins

POWER6	TXE6	RXE6	PM13	P13	PM14	P14	UART6 Operation	Pin Function	
								TxD6/P13	RxD6/P14
0	0	0	×	×	×	×	Stop	P13	P14
1	0	1	×	×	1	×	Reception	P13	RxD6
	1	0	0	1	×	×	Transmission	TxD6	P14
	1	1	0	1	1	×	Transmission/reception	TxD6	RxD6

Note Can be set as port function.

Remark ×: don't care

POWER6: Bit 7 of asynchronous serial interface operation mode register 6 (ASIM6)

TXE6: Bit 6 of ASIM6

RXE6: Bit 5 of ASIM6

PM1×: Port mode register

P1×: Port output latch

(2) Communication operation**(a) Format and waveform example of normal transmit/receive data**

Figures 12-13 and 12-14 show the format and waveform example of the normal transmit/receive data.

Figure 12-13. Format of Normal UART Transmit/Receive Data

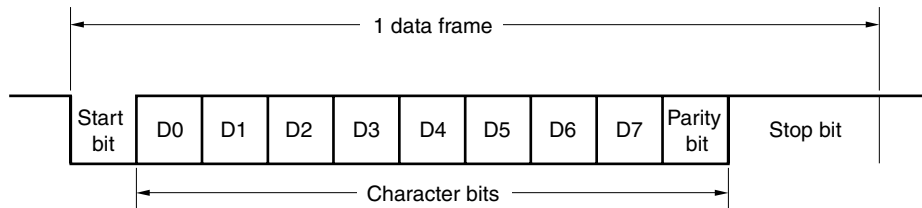
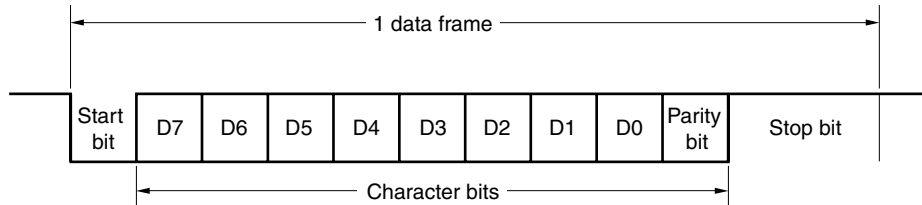
1. LSB-first transmission/reception**2. MSB-first transmission/reception**

One data frame consists of the following bits.

- Start bit ... 1 bit
- Character bits ... 7 or 8 bits
- Parity bit ... Even parity, odd parity, 0 parity, or no parity
- Stop bit ... 1 or 2 bits

The character bit length, parity, and stop bit length in one data frame are specified by asynchronous serial interface operation mode register 6 (ASIM6).

Whether data is communicated with the LSB or MSB first is specified by bit 1 (DIR6) of asynchronous serial interface control register 6 (ASICL6).

Whether the Tx/D6 pin outputs normal or inverted data is specified by bit 0 (TXDLV6) of ASICL6.

Figure 12-14. Example of Normal UART Transmit/Receive Data Waveform

1. Data length: 8 bits, LSB first, Parity: Even parity, Stop bit: 1 bit, Communication data: 55H

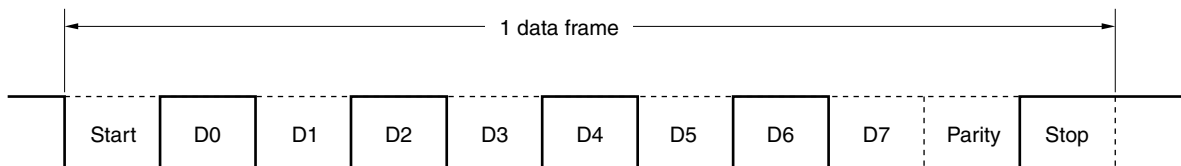

2. Data length: 8 bits, MSB first, Parity: Even parity, Stop bit: 1 bit, Communication data: 55H

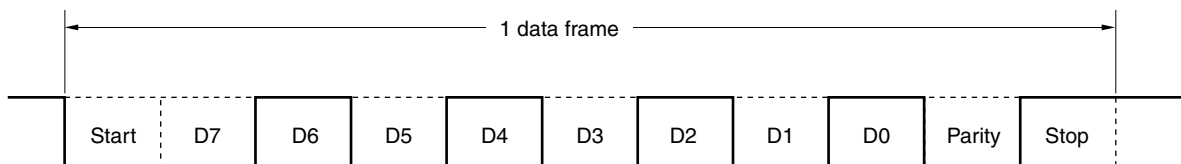

3. Data length: 8 bits, MSB first, Parity: Even parity, Stop bit: 1 bit, Communication data: 55H, TxD6 pin inverted output

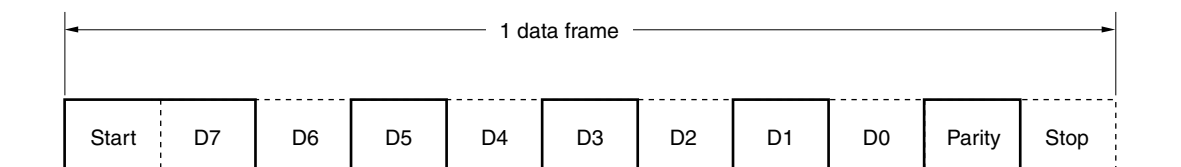

4. Data length: 7 bits, LSB first, Parity: Odd parity, Stop bit: 2 bits, Communication data: 36H

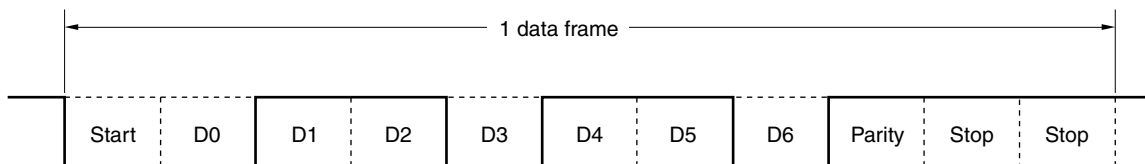

5. Data length: 8 bits, LSB first, Parity: None, Stop bit: 1 bit, Communication data: 87H

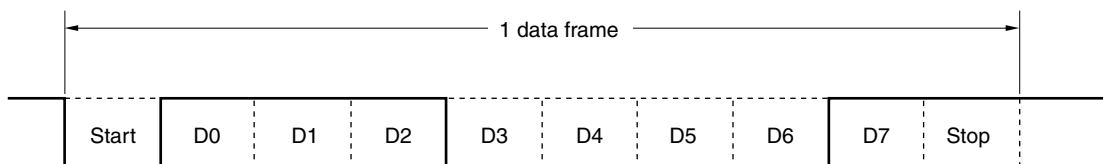

(b) Parity types and operation

The parity bit is used to detect a bit error in communication data. Usually, the same type of parity bit is used on both the transmission and reception sides. With even parity and odd parity, a 1-bit (odd number) error can be detected. With zero parity and no parity, an error cannot be detected.

Caution Fix the PS61 and PS60 bits to 0 when the device is used in LIN communication operation.

(i) Even parity

- Transmission

Transmit data, including the parity bit, is controlled so that the number of bits that are “1” is even. The value of the parity bit is as follows.

If transmit data has an odd number of bits that are “1”: 1

If transmit data has an even number of bits that are “1”: 0

- Reception

The number of bits that are “1” in the receive data, including the parity bit, is counted. If it is odd, a parity error occurs.

(ii) Odd parity

- Transmission

Unlike even parity, transmit data, including the parity bit, is controlled so that the number of bits that are “1” is odd.

If transmit data has an odd number of bits that are “1”: 0

If transmit data has an even number of bits that are “1”: 1

- Reception

The number of bits that are “1” in the receive data, including the parity bit, is counted. If it is even, a parity error occurs.

(iii) 0 parity

The parity bit is cleared to 0 when data is transmitted, regardless of the transmit data.

The parity bit is not detected when the data is received. Therefore, a parity error does not occur regardless of whether the parity bit is “0” or “1”.

(iv) No parity

No parity bit is appended to the transmit data.

Reception is performed assuming that there is no parity bit when data is received. Because there is no parity bit, a parity error does not occur.

(c) Normal transmission

When bit 7 (POWER6) of asynchronous serial interface operation mode register 6 (ASIM6) is set to 1 and bit 6 (TXE6) of ASIM6 is then set to 1, transmission is enabled. Transmission can be started by writing transmit data to transmit buffer register 6 (TXB6). The start bit, parity bit, and stop bit are automatically appended to the data.

When transmission is started, the data in TXB6 is transferred to transmit shift register 6 (TXS6). After that, the transmit data is sequentially output from TXS6 to the TxD6 pin. When transmission is completed, the parity and stop bits set by ASIM6 are appended and a transmission completion interrupt request (INTST6) is generated.

Transmission is stopped until the data to be transmitted next is written to TXB6.

Figure 12-15 shows the timing of the transmission completion interrupt request (INTST6). This interrupt occurs as soon as the last stop bit has been output.

Figure 12-15. Normal Transmission Completion Interrupt Request Timing

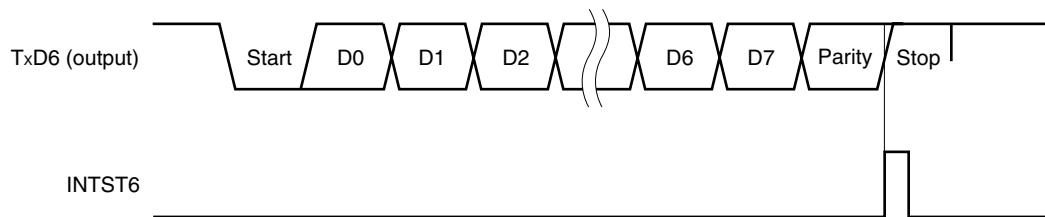
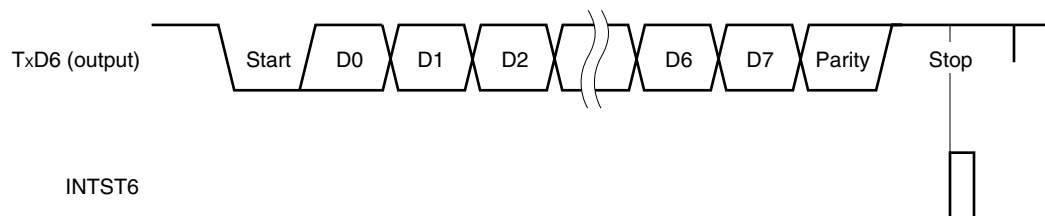
1. Stop bit length: 1**2. Stop bit length: 2**

(d) Continuous transmission

The next transmit data can be written to transmit buffer register 6 (TXB6) as soon as transmit shift register 6 (TXS6) has started its shift operation. Consequently, even while the INTST6 interrupt is being serviced after transmission of one data frame, data can be continuously transmitted and an efficient communication rate can be realized. In addition, the TXB6 register can be efficiently written twice (2 bytes) without having to wait for the transmission time of one data frame, by reading bit 0 (TXSF6) of asynchronous serial interface transmission status register 6 (ASIF6) when the transmission completion interrupt has occurred.

To transmit data continuously, be sure to reference the ASIF6 register to check the transmission status and whether the TXB6 register can be written, and then write the data.

- Cautions**
1. The TXBF6 and TXSF6 flags of the ASIF6 register change from “10” to “11”, and to “01” during continuous transmission. To check the status, therefore, do not use a combination of the TXBF6 and TXSF6 flags for judgment. Read only the TXBF6 flag when executing continuous transmission.
 2. When the device is incorporated in a LIN, the continuous transmission function cannot be used. Make sure that asynchronous serial interface transmission status register 6 (ASIF6) is 00H before writing transmit data to transmit buffer register 6 (TXB6).

TXBF6	Writing to TXB6 Register
0	Writing enabled
1	Writing disabled

Caution To transmit data continuously, write the first transmit data (first byte) to the TXB6 register. Be sure to check that the TXBF6 flag is “0”. If so, write the next transmit data (second byte) to the TXB6 register. If data is written to the TXB6 register while the TXBF6 flag is “1”, the transmit data cannot be guaranteed.

The communication status can be checked using the TXSF6 flag.

TXSF6	Transmission Status
0	Transmission is completed.
1	Transmission is in progress.

- Cautions**
1. To initialize the transmission unit upon completion of continuous transmission, be sure to check that the TXSF6 flag is “0” after generation of the transmission completion interrupt, and then execute initialization. If initialization is executed while the TXSF6 flag is “1”, the transmit data cannot be guaranteed.
 2. During continuous transmission, the next transmission may complete before execution of INTST6 interrupt servicing after transmission of one data frame. As a countermeasure, detection can be performed by developing a program that can count the number of transmit data and by referencing the TXSF6 flag.

Figure 12-16 shows an example of the continuous transmission processing flow.

Figure 12-16. Example of Continuous Transmission Processing Flow

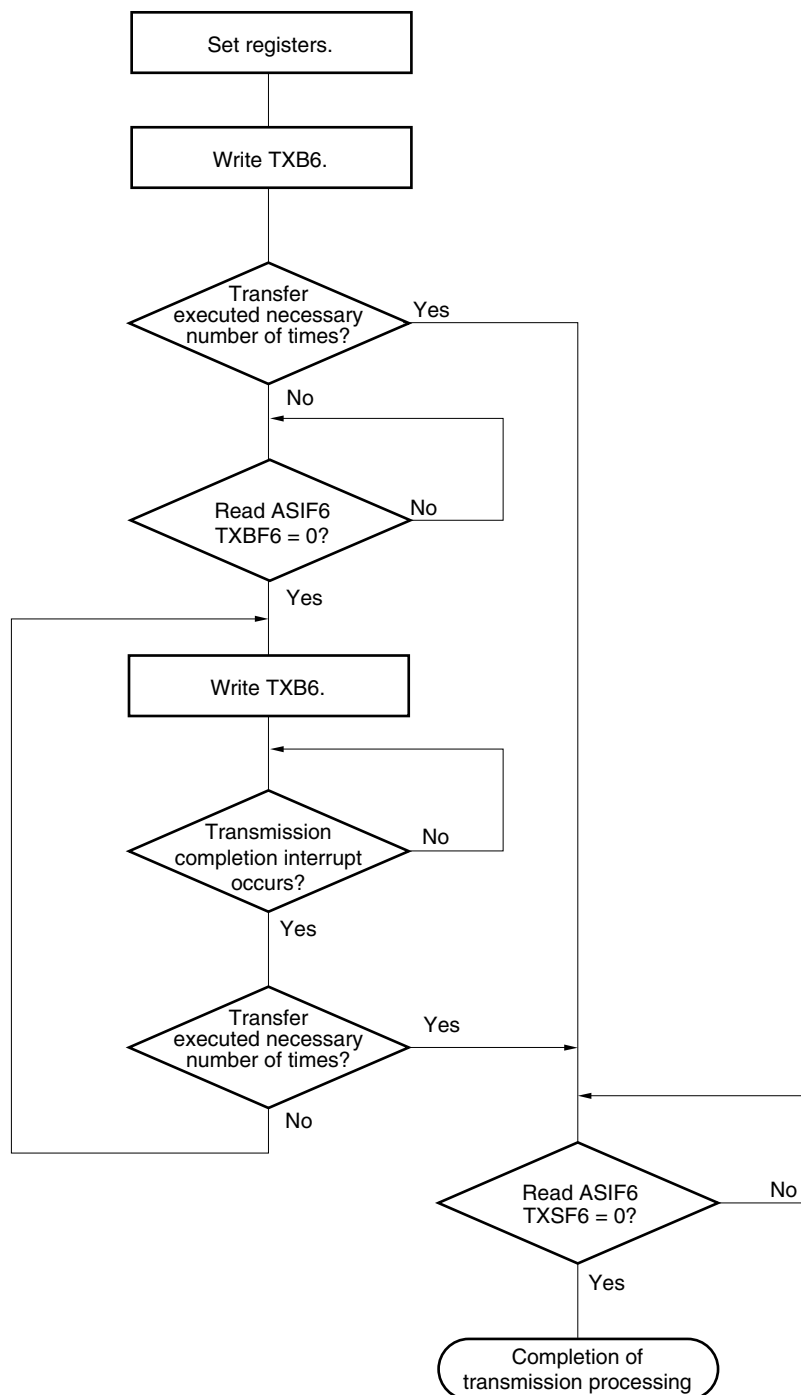

Remark TXB6: Transmit buffer register 6
 ASIF6: Asynchronous serial interface transmission status register 6
 TXBF6: Bit 1 of ASIF6 (transmit buffer data flag)
 TXSF6: Bit 0 of ASIF6 (transmit shift register data flag)

Figure 12-17 shows the timing of starting continuous transmission, and Figure 12-18 shows the timing of ending continuous transmission.

Figure 12-17. Timing of Starting Continuous Transmission

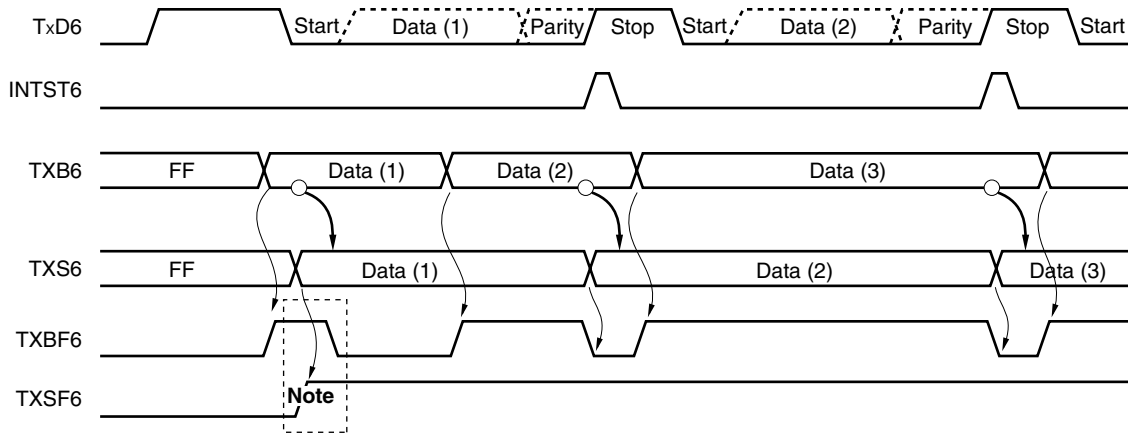

Note When ASIF6 is read, there is a period in which TXBF6 and TXSF6 = 1, 1. Therefore, judge whether writing is enabled using only the TXBF6 bit.

- Remark**
- TxD6: TxD6 pin (output)
 - INTST6: Interrupt request signal
 - TXB6: Transmit buffer register 6
 - TXS6: Transmit shift register 6
 - ASIF6: Asynchronous serial interface transmission status register 6
 - TXBF6: Bit 1 of ASIF6
 - TXSF6: Bit 0 of ASIF6

Figure 12-18. Timing of Ending Continuous Transmission

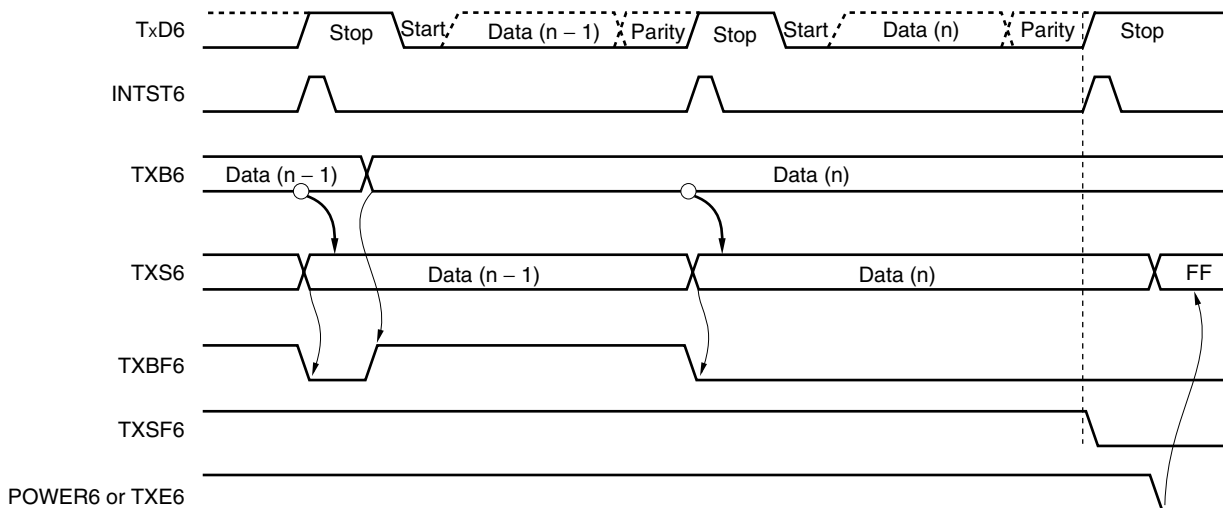

Remark	TxD6:	TxD6 pin (output)
	INTST6:	Interrupt request signal
	TXB6:	Transmit buffer register 6
	TXS6:	Transmit shift register 6
	ASIF6:	Asynchronous serial interface transmission status register 6
	TXBF6:	Bit 1 of ASIF6
	TXSF6:	Bit 0 of ASIF6
	POWER6:	Bit 7 of asynchronous serial interface operation mode register (ASIM6)
	TXE6:	Bit 6 of asynchronous serial interface operation mode register (ASIM6)

(e) Normal reception

Reception is enabled and the RxD6 pin input is sampled when bit 7 (POWER6) of asynchronous serial interface operation mode register 6 (ASIM6) is set to 1 and then bit 5 (RXE6) of ASIM6 is set to 1.

The 8-bit counter of the baud rate generator starts counting when the falling edge of the RxD6 pin input is detected. When the set value of baud rate generator control register 6 (BRGC6) has been counted, the RxD6 pin input is sampled again (∇ in Figure 12-19). If the RxD6 pin is low level at this time, it is recognized as a start bit.

When the start bit is detected, reception is started, and serial data is sequentially stored in the receive shift register (RXS6) at the set baud rate. When the stop bit has been received, the reception completion interrupt (INTSR6) is generated and the data of RXS6 is written to receive buffer register 6 (RXB6). If an overrun error (OVE6) occurs, however, the receive data is not written to RXB6.

Even if a parity error (PE6) occurs while reception is in progress, reception continues to the reception position of the stop bit, and a reception error interrupt (INTSR6/INTSRE6) is generated on completion of reception.

Figure 12-19. Reception Completion Interrupt Request Timing

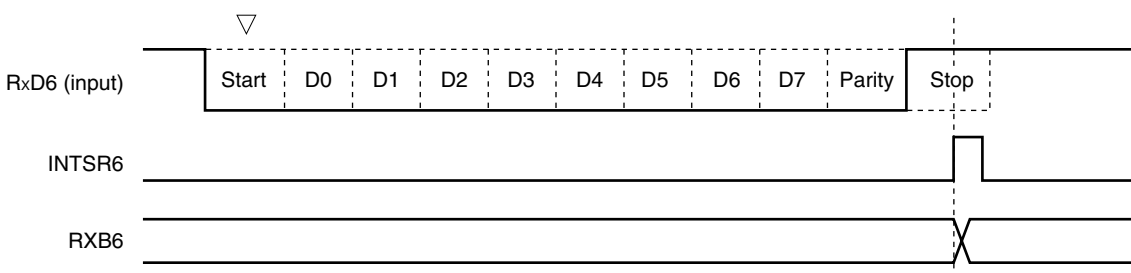

- Cautions**
1. If a reception error occurs, read ASIS6 and then RXB6 to clear the error flag. Otherwise, an overrun error will occur when the next data is received, and the reception error status will persist.
 2. Reception is always performed with the “number of stop bits = 1”. The second stop bit is ignored.
 3. Be sure to read asynchronous serial interface reception error status register 6 (ASIS6) before reading RXB6.

(f) Reception error

Three types of errors may occur during reception: a parity error, framing error, or overrun error. If the error flag of asynchronous serial interface reception error status register 6 (ASIS6) is set as a result of data reception, a reception error interrupt request (INTSR6/INTSRE6) is generated.

Which error has occurred during reception can be identified by reading the contents of ASIS6 in the reception error interrupt (INTSR6/INTSRE6) servicing (see **Figure 12-6**).

The contents of ASIS6 are cleared to 0 when ASIS6 is read.

Table 12-3. Cause of Reception Error

Reception Error	Cause
Parity error	The parity specified for transmission does not match the parity of the receive data.
Framing error	Stop bit is not detected.
Overrun error	Reception of the next data is completed before data is read from receive buffer register 6 (RXB6).

The reception error interrupt can be separated into reception completion interrupt (INTSR6) and error interrupt (INTSRE6) by clearing bit 0 (ISRM6) of asynchronous serial interface operation mode register 6 (ASIM6) to 0.

Figure 12-20. Reception Error Interrupt

1. If ISRM6 is cleared to 0 (reception completion interrupt (INTSR6) and error interrupt (INTSRE6) are separated)

(a) No error during reception

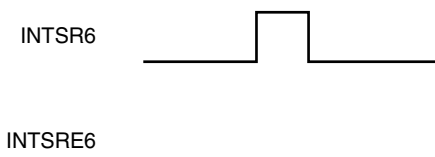

(b) Error during reception

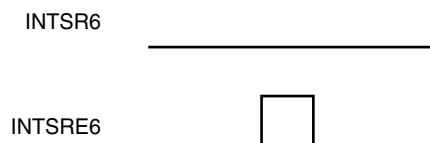

2. If ISRM6 is set to 1 (error interrupt is included in INTSR6)

(a) No error during reception

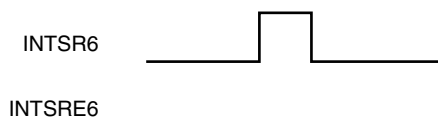

(b) Error during reception

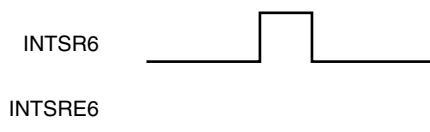

(g) Noise filter of receive data

The RXD6 signal is sampled with the base clock output by the prescaler block.

If two sampled values are the same, the output of the match detector changes, and the data is sampled as input data.

Because the circuit is configured as shown in Figure 12-21, the internal processing of the reception operation is delayed by two clocks from the external signal status.

Figure 12-21. Noise Filter Circuit

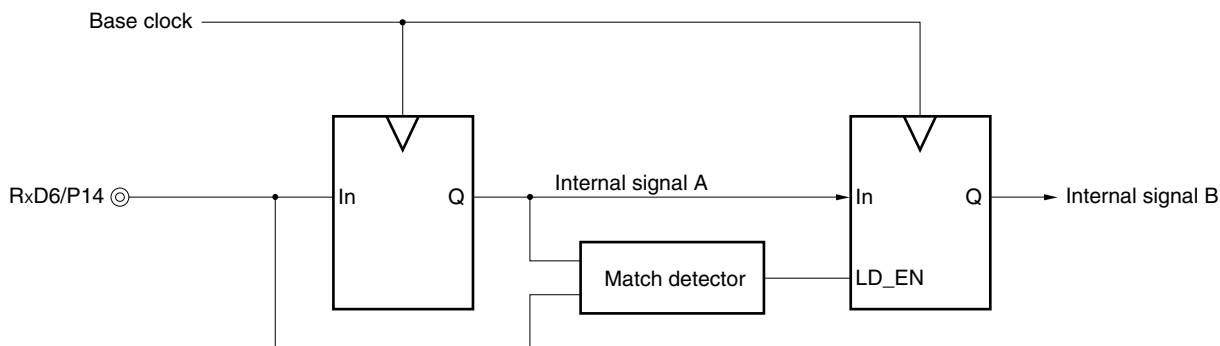

(h) SBF transmission

When the device is use in LIN communication operation, the SBF (Synchronous Break Field) transmission control function is used for transmission. For the transmission operation of LIN, see **Figure 12-1 LIN Transmission Operation**.

When bit 7 (POWER6) of asynchronous serial interface mode register 6 (ASIM6) is set to 1, the TxD6 pin outputs high level. Next, when bit 6 (TXE6) of ASIM6 is set to 1, the transmission enabled status is entered, and SBF transmission is started by setting bit 5 (SBTT6) of asynchronous serial interface control register 6 (ASICL6) to 1.

Thereafter, a low level of bits 13 to 20 (set by bits 4 to 2 (SBL62 to SBL60) of ASICL6) is output. Following the end of SBF transmission, the transmission completion interrupt request (INTST6) is generated and SBTT6 is automatically cleared. Thereafter, the normal transmission mode is restored.

Transmission is suspended until the data to be transmitted next is written to transmit buffer register 6 (TXB6), or until SBTT6 is set to 1.

Figure 12-22. SBF Transmission

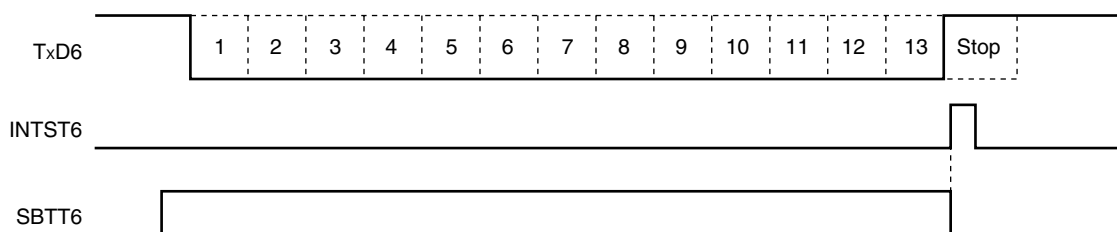

- Remark** TxD6: TxD6 pin (output)
 INTST6: Transmission completion interrupt request
 SBTT6: Bit 5 of asynchronous serial interface control register 6 (ASICL6)

(i) SBF reception

When the device is used in LIN communication operation, the SBF (Synchronous Break Field) reception control function is used for reception. For the reception operation of LIN, see **Figure 12-2 LIN Reception Operation**.

Reception is enabled when bit 7 (POWER6) of asynchronous serial interface operation mode register 6 (ASIM6) is set to 1 and then bit 5 (RXE6) of ASIM6 is set to 1. SBF reception is enabled when bit 6 (SBRT6) of asynchronous serial interface control register 6 (ASICL6) is set to 1. In the SBF reception enabled status, the RxD6 pin is sampled and the start bit is detected in the same manner as the normal reception enable status.

When the start bit has been detected, reception is started, and serial data is sequentially stored in the receive shift register 6 (RXS6) at the set baud rate. When the stop bit is received and if the width of SBF is 11 bits or more, a reception completion interrupt request (INTSR6) is generated as normal processing. At this time, the SBRF6 and SBRT6 bits are automatically cleared, and SBF reception ends. Detection of errors, such as OVE6, PE6, and FE6 (bits 0 to 2 of asynchronous serial interface reception error status register 6 (ASIS6)) is suppressed, and error detection processing of UART communication is not performed. In addition, data transfer between receive shift register 6 (RXS6) and receive buffer register 6 (RXB6) is not performed, and the reset value of FFH is retained. If the width of SBF is 10 bits or less, an interrupt does not occur as error processing after the stop bit has been received, and the SBF reception mode is restored. In this case, the SBRF6 and SBRT6 bits are not cleared.

Figure 12-23. SBF Reception

1. Normal SBF reception (stop bit is detected with a width of more than 10.5 bits)

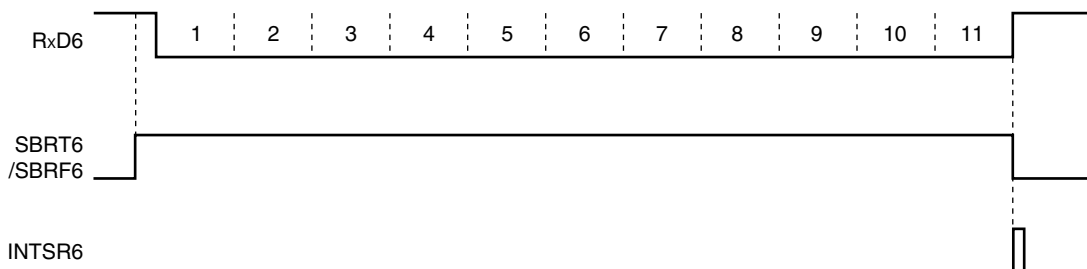

2. SBF reception error (stop bit is detected with a width of 10.5 bits or less)

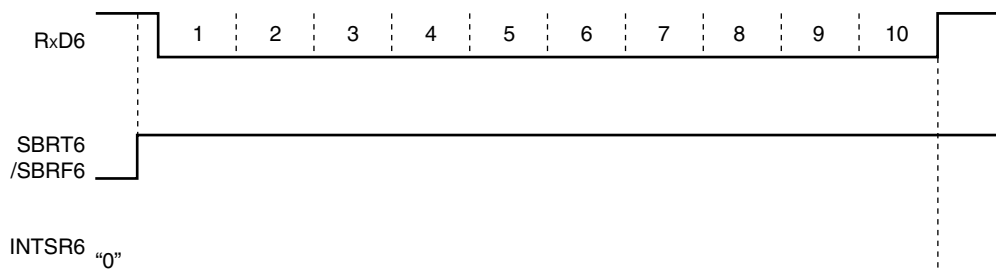

- Remark**
- RxD6: RxD6 pin (input)
 - SBRT6: Bit 6 of asynchronous serial interface control register 6 (ASICL6)
 - SBRF6: Bit 7 of ASICL6
 - INTSR6: Reception completion interrupt request

12.4.3 Dedicated baud rate generator

The dedicated baud rate generator consists of a source clock selector and an 8-bit programmable counter, and generates a serial clock for transmission/reception of UART6.

Separate 8-bit counters are provided for transmission and reception.

(1) Configuration of baud rate generator

- Base clock

The clock selected by bits 3 to 0 (TPS63 to TPS60) of clock selection register 6 (CKSR6) is supplied to each module when bit 7 (POWER6) of asynchronous serial interface operation mode register 6 (ASIM6) is 1. This clock is called the base clock and its frequency is called f_{XCLK6} . The base clock is fixed to low level when POWER6 = 0.

- Transmission counter

This counter stops operation, cleared to 0, when bit 7 (POWER6) or bit 6 (TXE6) of asynchronous serial interface operation mode register 6 (ASIM6) is 0.

It starts counting when POWER6 = 1 and TXE6 = 1.

The counter is cleared to 0 when the first data transmitted is written to transmit buffer register 6 (TXB6).

If data are continuously transmitted, the counter is cleared to 0 again when one frame of data has been completely transmitted. If there is no data to be transmitted next, the counter is not cleared to 0 and continues counting until POWER6 or TXE6 is cleared to 0.

- Reception counter

This counter stops operation, cleared to 0, when bit 7 (POWER6) or bit 5 (RXE6) of asynchronous serial interface operation mode register 6 (ASIM6) is 0.

It starts counting when the start bit has been detected.

The counter stops operation after one frame has been received, until the next start bit is detected.

Figure 12-24. Configuration of Baud Rate Generator

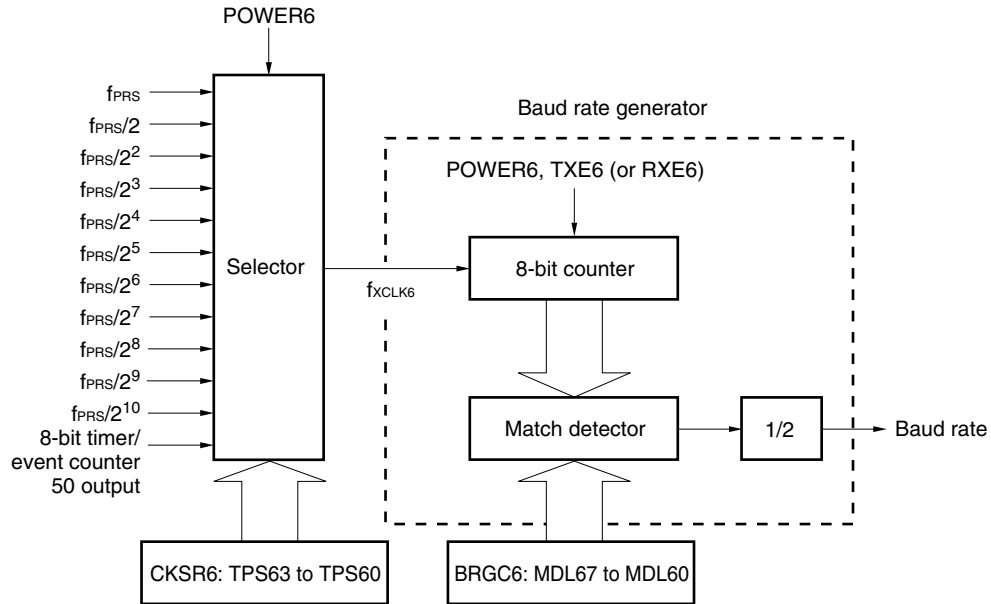

Remark POWER6: Bit 7 of asynchronous serial interface operation mode register 6 (ASIM6)
 TXE6: Bit 6 of ASIM6
 RXE6: Bit 5 of ASIM6
 CKSR6: Clock selection register 6
 BRGC6: Baud rate generator control register 6

(2) Generation of serial clock

A serial clock to be generated can be specified by using clock selection register 6 (CKSR6) and baud rate generator control register 6 (BRGC6).

The clock to be input to the 8-bit counter can be set by bits 3 to 0 (TPS63 to TPS60) of CKSR6 and the division value ($f_{XCLK6}/4$ to $f_{XCLK6}/255$) of the 8-bit counter can be set by bits 7 to 0 (MDL67 to MDL60) of BRGC6.

<R>

12.4.4 Calculation of baud rate

(1) Baud rate calculation expression

The baud rate can be calculated by the following expression.

- Baud rate = $\frac{f_{CLK6}}{2 \times k}$ [bps]

f_{CLK6} : Frequency of base clock selected by TPS63 to TPS60 bits of CKSR6 register

k: Value set by MDL67 to MDL60 bits of BRGC6 register (k = 4, 5, 6, ..., 255)

Table 12-4. Set Value of TPS63 to TPS60

TPS63	TPS62	TPS61	TPS60	Base Clock (f_{CLK6}) Selection				
				$f_{PRS} =$ 2 MHz	$f_{PRS} =$ 5 MHz	$f_{PRS} =$ 10 MHz	$f_{PRS} =$ 20 MHz	
0	0	0	0	f_{PRS}	2 MHz	5 MHz	10 MHz	20 MHz
0	0	0	1	$f_{PRS}/2$	1 MHz	2.5 MHz	5 MHz	10 MHz
0	0	1	0	$f_{PRS}/2^2$	500 kHz	1.25 MHz	2.5 MHz	5 MHz
0	0	1	1	$f_{PRS}/2^3$	250 kHz	625 kHz	1.25 MHz	2.5 MHz
0	1	0	0	$f_{PRS}/2^4$	125 kHz	312.5 kHz	625 kHz	1.25 MHz
0	1	0	1	$f_{PRS}/2^5$	62.5 kHz	156.25 kHz	312.5 kHz	625 kHz
0	1	1	0	$f_{PRS}/2^6$	31.25 kHz	78.13 kHz	156.25 kHz	312.5 kHz
0	1	1	1	$f_{PRS}/2^7$	15.625 kHz	39.06 kHz	78.13 kHz	156.25 kHz
1	0	0	0	$f_{PRS}/2^8$	7.813 kHz	19.53 kHz	39.06 kHz	78.13 kHz
1	0	0	1	$f_{PRS}/2^9$	3.906 kHz	9.77 kHz	19.53 kHz	39.06 kHz
1	0	1	0	$f_{PRS}/2^{10}$	1.953 kHz	4.88 kHz	9.77 kHz	19.53 kHz
1	0	1	1	TM50 output				
Other than above				Setting prohibited				

(2) Error of baud rate

The baud rate error can be calculated by the following expression.

- Error (%) = $\left(\frac{\text{Actual baud rate (baud rate with error)}}{\text{Desired baud rate (correct baud rate)}} - 1 \right) \times 100$ [%]

Cautions 1. Keep the baud rate error during transmission to within the permissible error range at the reception destination.

2. Make sure that the baud rate error during reception satisfies the range shown in (4) Permissible baud rate range during reception.

Example: Frequency of base clock = 10 MHz = 10,000,000 Hz

Set value of MDL67 to MDL60 bits of BRGC6 register = 00100001B (k = 33)

Target baud rate = 153600 bps

$$\begin{aligned} \text{Baud rate} &= 10 \text{ M} / (2 \times 33) \\ &= 10000000 / (2 \times 33) = 151,515 \text{ [bps]} \end{aligned}$$

$$\begin{aligned} \text{Error} &= (151515/153600 - 1) \times 100 \\ &= -1.357 \text{ [%]} \end{aligned}$$

(3) Example of setting baud rate

Table 12-5. Set Data of Baud Rate Generator

Baud Rate [bps]	f _{PRS} = 2.0 MHz				f _{PRS} = 5.0 MHz				f _{PRS} = 10.0 MHz				f _{PRS} = 20.0 MHz			
	TPS63-TPS60	k	Calculated Value	ERR [%]	TPS63-TPS60	k	Calculated Value	ERR [%]	TPS63-TPS60	k	Calculated Value	ERR [%]	TPS63-TPS60	k	Calculated Value	ERR [%]
300	8H	13	301	0.16	7H	65	301	0.16	8H	65	301	0.16	9H	65	301	0.16
600	7H	13	601	0.16	6H	65	601	0.16	7H	65	601	0.16	8H	65	601	0.16
1200	6H	13	1202	0.16	5H	65	1202	0.16	6H	65	1202	0.16	7H	65	1202	0.16
2400	5H	13	2404	0.16	4H	65	2404	0.16	5H	65	2404	0.16	6H	65	2404	0.16
4800	4H	13	4808	0.16	3H	65	4808	0.16	4H	65	4808	0.16	5H	65	4808	0.16
9600	3H	13	9615	0.16	2H	65	9615	0.16	3H	65	9615	0.16	4H	65	9615	0.16
19200	2H	13	19231	0.16	1H	65	19231	0.16	2H	65	19231	0.16	3H	65	19231	0.16
24000	1H	21	23810	-0.79	3H	13	24038	0.16	4H	13	24038	0.16	5H	13	24038	0.16
31250	1H	4	31250	0	4H	5	31250	0	5H	5	31250	0	6H	5	31250	0
38400	1H	13	38462	0.16	0H	65	38462	0.16	1H	65	38462	0.16	2H	65	38462	0.16
48000	0H	21	47619	-0.79	2H	13	48077	0.16	3H	13	48077	0.16	4H	13	48077	0.16
76800	0H	13	76923	0.16	0H	33	75758	-1.36	0H	65	76923	0.16	1H	65	76923	0.16
115200	0H	9	111111	-3.55	1H	11	113636	-1.36	0H	43	116279	0.94	0H	87	114943	-0.22
153600	-	-	-	-	1H	8	156250	1.73	0H	33	151515	-1.36	1H	33	151515	-1.36
312500	-	-	-	-	0H	8	312500	0	1H	8	312500	0	2H	8	312500	0
<R> 625000	-	-	-	-	0H	4	625000	0	1H	4	625000	0	2H	4	625000	0

Remark TPS63 to TPS60: Bits 3 to 0 of clock selection register 6 (CKSR6) (setting of base clock (f_{CLK6}))

k: Value set by MDL67 to MDL60 bits of baud rate generator control register 6 (BRGC6) (k = 4, 5, 6, ..., 255)

f_{PRS}: Peripheral hardware clock frequency

ERR: Baud rate error

(4) Permissible baud rate range during reception

The permissible error from the baud rate at the transmission destination during reception is shown below.

Caution Make sure that the baud rate error during reception is within the permissible error range, by using the calculation expression shown below.

Figure 12-25. Permissible Baud Rate Range During Reception

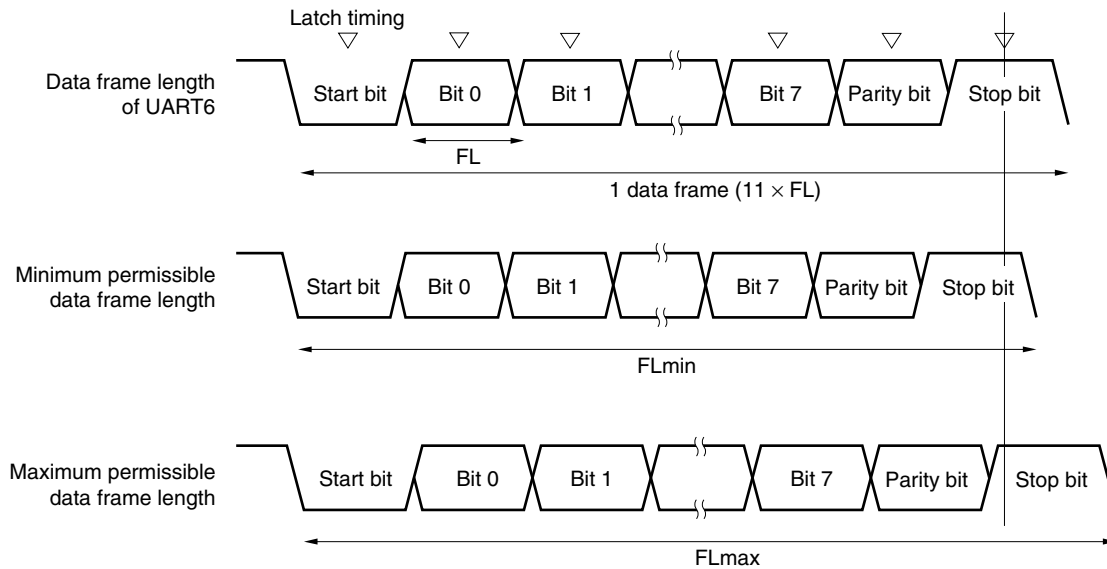

As shown in Figure 15-25, the latch timing of the receive data is determined by the counter set by baud rate generator control register 6 (BRGC6) after the start bit has been detected. If the last data (stop bit) meets this latch timing, the data can be correctly received.

Assuming that 11-bit data is received, the theoretical values can be calculated as follows.

$$FL = (\text{Brate})^{-1}$$

Brate: Baud rate of UART6

k: Set value of BRGC6

FL: 1-bit data length

Margin of latch timing: 2 clocks

$$\text{Minimum permissible data frame length: } FL_{\min} = 11 \times FL - \frac{k-2}{2k} \times FL = \frac{21k+2}{2k} FL$$

Therefore, the maximum receivable baud rate at the transmission destination is as follows.

$$BR_{\max} = (FL_{\min}/11)^{-1} = \frac{22k}{21k+2} \text{ Brate}$$

Similarly, the maximum permissible data frame length can be calculated as follows.

$$\frac{10}{11} \times FL_{\max} = 11 \times FL - \frac{k+2}{2 \times k} \times FL = \frac{21k-2}{2 \times k} FL$$

$$FL_{\max} = \frac{21k-2}{20k} FL \times 11$$

Therefore, the minimum receivable baud rate at the transmission destination is as follows.

$$BR_{\min} = (FL_{\max}/11)^{-1} = \frac{20k}{21k-2} \text{ Brate}$$

The permissible baud rate error between UART6 and the transmission destination can be calculated from the above minimum and maximum baud rate expressions, as follows.

Table 12-6. Maximum/Minimum Permissible Baud Rate Error

Division Ratio (k)	Maximum Permissible Baud Rate Error	Minimum Permissible Baud Rate Error
4	+2.33%	-2.44%
8	+3.53%	-3.61%
20	+4.26%	-4.31%
50	+4.56%	-4.58%
100	+4.66%	-4.67%
255	+4.72%	-4.73%

<R>

- Remarks**
1. The permissible error of reception depends on the number of bits in one frame, input clock frequency, and division ratio (k). The higher the input clock frequency and the higher the division ratio (k), the higher the permissible error.
 2. k: Set value of BRGC6

(5) Data frame length during continuous transmission

When data is continuously transmitted, the data frame length from a stop bit to the next start bit is extended by two clocks of base clock from the normal value. However, the result of communication is not affected because the timing is initialized on the reception side when the start bit is detected.

Figure 12-26. Data Frame Length During Continuous Transmission

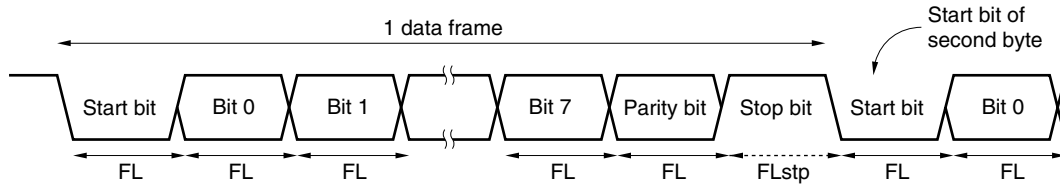

Where the 1-bit data length is FL, the stop bit length is FLstp, and base clock frequency is f_{CLK6} , the following expression is satisfied.

$$FL_{stp} = FL + 2/f_{CLK6}$$

Therefore, the data frame length during continuous transmission is:

$$\text{Data frame length} = 11 \times FL + 2/f_{CLK6}$$

CHAPTER 13 SERIAL INTERFACE CSI10

13.1 Functions of Serial Interface CSI10

Serial interface CSI10 has the following two modes.

- Operation stop mode
- 3-wire serial I/O mode

(1) Operation stop mode

This mode is used when serial communication is not performed and can enable a reduction in the power consumption.

For details, see **13.4.1 Operation stop mode**.

(2) 3-wire serial I/O mode (MSB/LSB-first selectable)

This mode is used to communicate 8-bit data using three lines: a serial clock line ($\overline{\text{SCK10}}$) and two serial data lines (SI10 and SO10).

The processing time of data communication can be shortened in the 3-wire serial I/O mode because transmission and reception can be simultaneously executed.

In addition, whether 8-bit data is communicated with the MSB or LSB first can be specified, so this interface can be connected to any device.

The 3-wire serial I/O mode is used for connecting peripheral ICs and display controllers with a clocked serial interface.

For details, see **13.4.2 3-wire serial I/O mode**.

13.2 Configuration of Serial Interface CSI10

Serial interface CSI10 includes the following hardware.

Table 13-1. Configuration of Serial Interface CSI10

Item	Configuration
Controller	Transmit controller Clock start/stop controller & clock phase controller
Registers	Transmit buffer register 10 (SOTB10) Serial I/O shift register 10 (SIO10)
Control registers	Serial operation mode register 10 (CSIM10) Serial clock selection register 10 (CSIC10) Port mode register 1 (PM1) Port register 1 (P1)

Figure 13-1. Block Diagram of Serial Interface CSI10

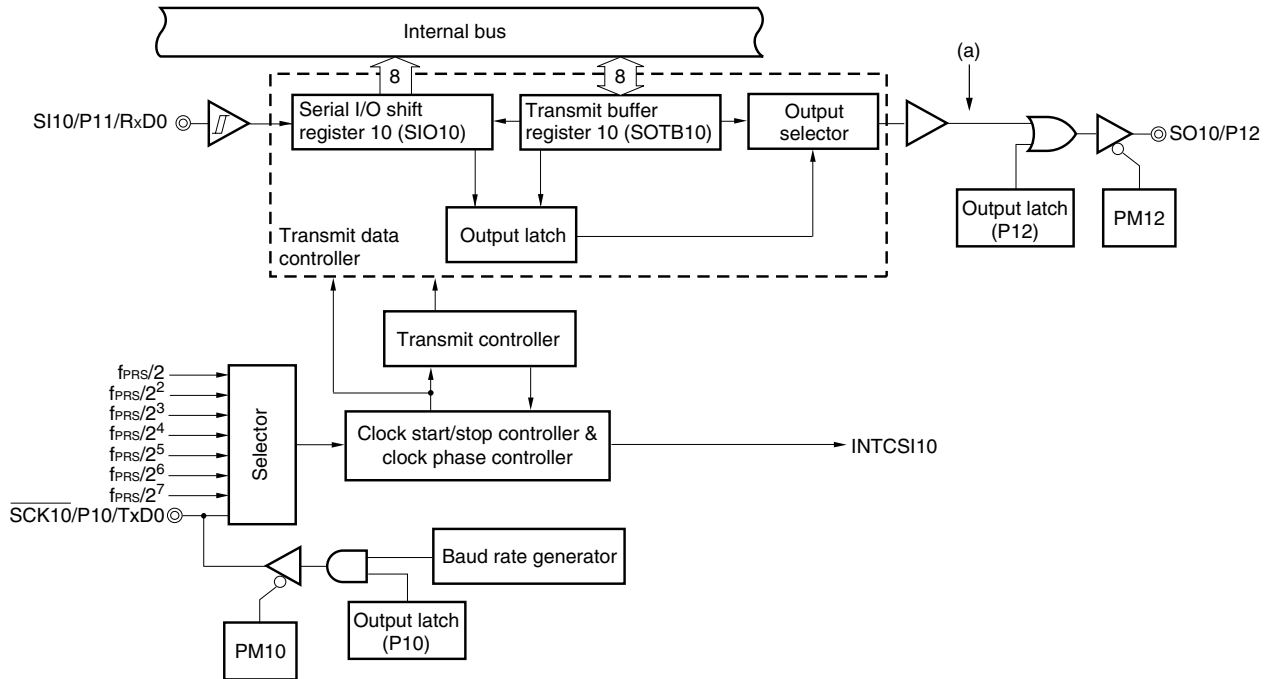

Remark (a): SO10 output

(1) Transmit buffer register 10 (SOTB10)

This register sets the transmit data.

Transmission/reception is started by writing data to SOTB10 when bit 7 (CSIE10) and bit 6 (TRMD10) of serial operation mode register 10 (CSIM10) is 1.

The data written to SOTB10 is converted from parallel data into serial data by serial I/O shift register 10, and output to the serial output pin (SO10).

SOTB10 can be written or read by an 8-bit memory manipulation instruction.

Reset signal generation sets this register to 00H.

Caution Do not access SOTB10 when CSOT10 = 1 (during serial communication).

(2) Serial I/O shift register 10 (SIO10)

This is an 8-bit register that converts data from parallel data into serial data and vice versa.

This register can be read by an 8-bit memory manipulation instruction.

Reception is started by reading data from SIO10 if bit 6 (TRMD10) of serial operation mode register 10 (CSIM10) is 0.

During reception, the data is read from the serial input pin (SI100) to SIO10.

Reset signal generation sets this register to 00H.

Caution Do not access SIO10 when CSOT10 = 1 (during serial communication).

13.3 Registers Controlling Serial Interface CSI10

Serial interface CSI10 is controlled by the following four registers.

- Serial operation mode register 10 (CSIM10)
- Serial clock selection register 10 (CSIC10)
- Port mode register 1 (PM1)
- Port register 1 (P1)

(1) Serial operation mode register 10 (CSIM10)

CSIM10 is used to select the operation mode and enable or disable operation.

CSIM10 can be set by a 1-bit or 8-bit memory manipulation instruction.

Reset signal generation sets this register to 00H.

Figure 13-2. Format of Serial Operation Mode Register 10 (CSIM10)

Address: FF80H After reset: 00H R/W^{Note 1}

Symbol	<7>	6	5	4	3	2	1	0
CSIM10	CSIE10	TRMD10	0	DIR10	0	0	0	CSOT10

CSIE10	Operation control in 3-wire serial I/O mode
0	Disables operation ^{Note 2} and asynchronously resets the internal circuit ^{Note 3} .
1	Enables operation

TRMD10 ^{Note 4}	Transmit/receive mode control
0 ^{Note 5}	Receive mode (transmission disabled).
1	Transmit/receive mode

DIR10 ^{Note 6}	First bit specification
0	MSB
1	LSB

CSOT10	Communication status flag
0	Communication is stopped.
1	Communication is in progress.

- Notes**
1. Bit 0 is a read-only bit.
 2. To use P10/ $\overline{\text{SCK10}}$ /TxD0 and P12/SO10 as general-purpose ports, set CSIM10 in the default status (00H).
 3. Bit 0 (CSOT10) of CSIM10 and serial I/O shift register 10 (SIO10) are reset.
 4. Do not rewrite TRMD10 when CSOT10 = 1 (during serial communication).
 5. The SO10 output (see **(a)** in **Figure 13-1**) is fixed to the low level when TRMD10 is 0. Reception is started when data is read from SIO10.
 6. Do not rewrite DIR10 when CSOT10 = 1 (during serial communication).

Caution Be sure to clear bits 5 and 3 through 1 to 0.

(2) Serial clock selection register 10 (CSIC10)

This register specifies the timing of the data transmission/reception and sets the serial clock.

CSIC10 can be set by a 1-bit or 8-bit memory manipulation instruction.

Reset signal generation sets this register to 00H.

Figure 13-3. Format of Serial Clock Selection Register 10 (CSIC10)

Address: FF81H After reset: 00H R/W

Symbol	7	6	5	4	3	2	1	0
CSIC10	0	0	0	CKP10	DAP10	CKS102	CKS101	CKS100

CKP10	DAP10	Specification of data transmission/reception timing	Type
0	0		1
0	1		2
1	0		3
1	1		4

CKS102	CKS101	CKS100	CS10 serial clock selection				Mode	
			f _{PRS} = 2 MHz	f _{PRS} = 5 MHz	f _{PRS} = 10 MHz	f _{PRS} = 20 MHz		
0	0	0	f _{PRS} /2	1 MHz	2.5 MHz	5 MHz	10 MHz	Master mode
0	0	1	f _{PRS} /2 ²	500 kHz	1.25 MHz	2.5 MHz	5 MHz	
0	1	0	f _{PRS} /2 ³	250 kHz	625 kHz	1.25 MHz	2.5 MHz	
0	1	1	f _{PRS} /2 ⁴	125 kHz	312.5 kHz	625 kHz	1.25 MHz	
1	0	0	f _{PRS} /2 ⁵	62.5 kHz	156.25 kHz	312.5 kHz	625 kHz	
1	0	1	f _{PRS} /2 ⁶	31.25 kHz	78.13 kHz	156.25 kHz	312.5 kHz	
1	1	0	f _{PRS} /2 ⁷	15.63 kHz	39.06 kHz	78.13 kHz	156.25 kHz	
1	1	1	External clock input to SCK10				Slave mode	

- Cautions**
1. Do not write to CSIC10 while CSIE10 = 1 (operation enabled).
 2. To use P10/SCK10/TxD0 and P12/SO10 as general-purpose ports, set CSIC10 in the default status (00H).
 3. The phase type of the data clock is type 1 after reset.

Remark f_{PRS}: Peripheral hardware clock frequency

(3) Port mode registers 1 (PM1)

These registers set port 1 input/output in 1-bit units.

When using P10/ $\overline{\text{SCK10}}$ as the clock output pin of the serial interface, clear PM10 to 0, and set the output latch of P10 to 1.

When using P12/SO10 as the data output pin of the serial interface, clear PM12 and the output latch of P12 to 0.

When using P10/ $\overline{\text{SCK10}}$ as the clock input pin of the serial interface, P11/SI10/RxD0 as the data input pin, set PM10 and PM11 to 1. At this time, the output latches of P10 and P11 may be 0 or 1.

PM1 can be set by a 1-bit or 8-bit memory manipulation instruction.

Reset signal generation sets these registers to FFH.

Figure 13-4. Format of Port Mode Register 1 (PM1)

Address: FF21H After reset: FFH R/W

Symbol	7	6	5	4	3	2	1	0
PM1	PM17	PM16	PM15	PM14	PM13	PM12	PM11	PM10

PM1n	P1n pin I/O mode selection (n = 0 to 7)
0	Output mode (output buffer on)
1	Input mode (output buffer off)

13.4 Operation of Serial Interface CSI10

Serial interface CSI10 can be used in the following two modes.

- Operation stop mode
- 3-wire serial I/O mode

13.4.1 Operation stop mode

Serial communication is not executed in this mode. Therefore, the power consumption can be reduced. In addition, the P10/SCK10/TxD0, P11/SI10/RxD0, and P12/SO10 pins can be used as ordinary I/O port pins in this mode.

(1) Register used

The operation stop mode is set by serial operation mode register 10 (CSIM10).

To set the operation stop mode, clear bit 7 (CSIE10) of CSIM10 to 0.

(a) Serial operation mode register 10 (CSIM10)

CSIM10 can be set by a 1-bit or 8-bit memory manipulation instruction.

Reset signal generation sets CSIM10 to 00H.

Address: FF80H After reset: 00H R/W

Symbol	<7>	6	5	4	3	2	1	0
CSIM10	CSIE10	TRMD10	0	DIR10	0	0	0	CSOT10
	CSIE10	Operation control in 3-wire serial I/O mode						
	0	Disables operation ^{Note 1} and asynchronously resets the internal circuit ^{Note 2} .						

Notes 1. To use P10/SCK10/TxD0 and P12/SO10 as general-purpose ports, set CSIM10 in the default status (00H).

2. Bit 0 (CSOT10) of CSIM10 and serial I/O shift register 10 (SIO10) are reset.

13.4.2 3-wire serial I/O mode

The 3-wire serial I/O mode is used for connecting peripheral ICs and display controllers with a clocked serial interface.

In this mode, communication is executed by using three lines: the serial clock ($\overline{\text{SCK10}}$), serial output (SO10), and serial input (SI10) lines.

(1) Registers used

- Serial operation mode register 10 (CSIM10)
- Serial clock selection register 10 (CSIC10)
- Port mode register 1 (PM1)
- Port register 1 (P1)

The basic procedure of setting an operation in the 3-wire serial I/O mode is as follows.

- <1> Set the CSIC10 register (see **Figures 13-3**).
- <2> Set bits 4, and 6 (DIR10, and TRMD10) of the CSIM10 register (see **Figures 13-2**).
- <3> Set bit 7 (CSIE10) of the CSIM10 register to 1. → Transmission/reception is enabled.
- <4> Write data to transmit buffer register 10 (SOTB10). → Data transmission/reception is started.
Read data from serial I/O shift register 10 (SIO10). → Data reception is started.

Caution Take relationship with the other party of communication when setting the port mode register and port register.

The relationship between the register settings and pins is shown below.

Table 13-2. Relationship Between Register Settings and Pins

CSIE10	TRMD10	PM11	P11	PM12	P12	PM10	P10	CSI10 Operation	Pin Function		
									SI10/RxD0/ P11	SO10/P12	$\overline{\text{SCK10}}$ / TxD0/P10 ^{Note 2}
0	×	× ^{Note 1}	× ^{Note 1}	× ^{Note 1}	× ^{Note 1}	× ^{Note 1}	× ^{Note 1}	Stop	RxD0/P11	P12	TxD0/ P10 ^{Note 2}
1	0	1	×	× ^{Note 1}	× ^{Note 1}	1	×	Slave reception ^{Note 3}	SI10	P12	$\overline{\text{SCK10}}$ (input) ^{Note 3}
1	1	× ^{Note 1}	× ^{Note 1}	0	0	1	×	Slave transmission ^{Note 3}	RxD0/P11	SO10	$\overline{\text{SCK10}}$ (input) ^{Note 3}
1	1	1	×	0	0	1	×	Slave transmission/ reception ^{Note 3}	SI10	SO10	$\overline{\text{SCK10}}$ (input) ^{Note 3}
1	0	1	×	× ^{Note 1}	× ^{Note 1}	0	1	Master reception	SI10	P12	$\overline{\text{SCK10}}$ (output)
1	1	× ^{Note 1}	× ^{Note 1}	0	0	0	1	Master transmission	RxD0/P11	SO10	$\overline{\text{SCK10}}$ (output)
1	1	1	×	0	0	0	1	Master transmission/ reception	SI10	SO10	$\overline{\text{SCK10}}$ (output)

- Notes**
- Can be set as port function.
 - To use P10/ $\overline{\text{SCK10}}$ /TxD0 as port pins, clear CKP10 to 0.
 - To use the slave mode, set CKS102, CKS101, and CKS100 to 1, 1, 1.

Remark

- ×: don't care
- CSIE10: Bit 7 of serial operation mode register 10 (CSIM10)
- TRMD10: Bit 6 of CSIM10
- CKP10: Bit 4 of serial clock selection register 10 (CSIC10)
- CKS102, CKS101, CKS100: Bits 2 to 0 of CSIC10
- PM1×: Port mode register
- P1×: Port output latch

(2) Communication operation

In the 3-wire serial I/O mode, data is transmitted or received in 8-bit units. Each bit of the data is transmitted or received in synchronization with the serial clock.

Data can be transmitted or received if bit 6 (TRMD10) of serial operation mode register 10 (CSIM10) is 1. Transmission/reception is started when a value is written to transmit buffer register 10 (SOTB10). In addition, data can be received when bit 6 (TRMD10) of serial operation mode register 10 (CSIM10) is 0.

Reception is started when data is read from serial I/O shift register 10 (SIO10).

After communication has been started, bit 0 (CSOT10) of CSIM10 is set to 1. When communication of 8-bit data has been completed, a communication completion interrupt request flag (CSIIF10) is set, and CSOT10 is cleared to 0. Then the next communication is enabled.

Caution Do not access the control register and data register when CSOT10 = 1 (during serial communication).

Figure 13-5. Timing in 3-Wire Serial I/O Mode (1/2)

(a) Transmission/reception timing (Type 1: TRMD10 = 1, DIR10 = 0, CKP10 = 0, DAP10 = 0)

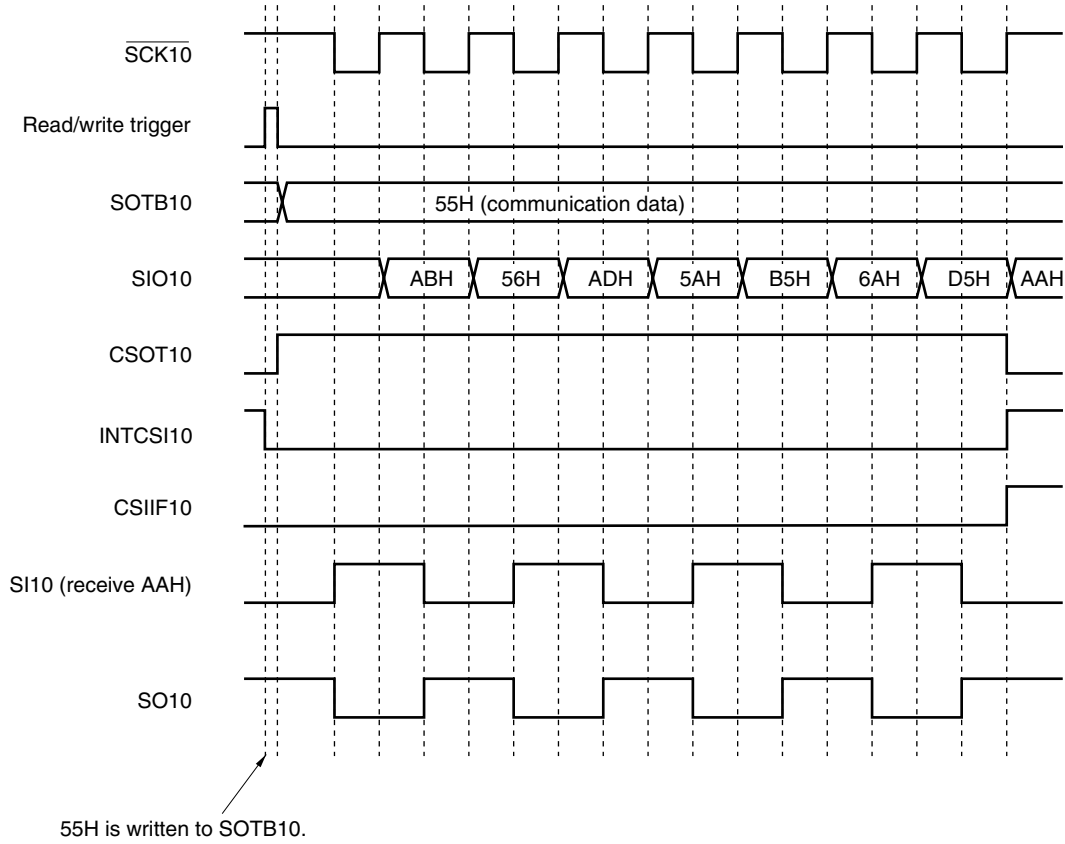

Figure 13-5. Timing in 3-Wire Serial I/O Mode (2/2)

(b) Transmission/reception timing (Type 2: TRMD10 = 1, DIR10 = 0, CKP10 = 0, DAP10 = 1)

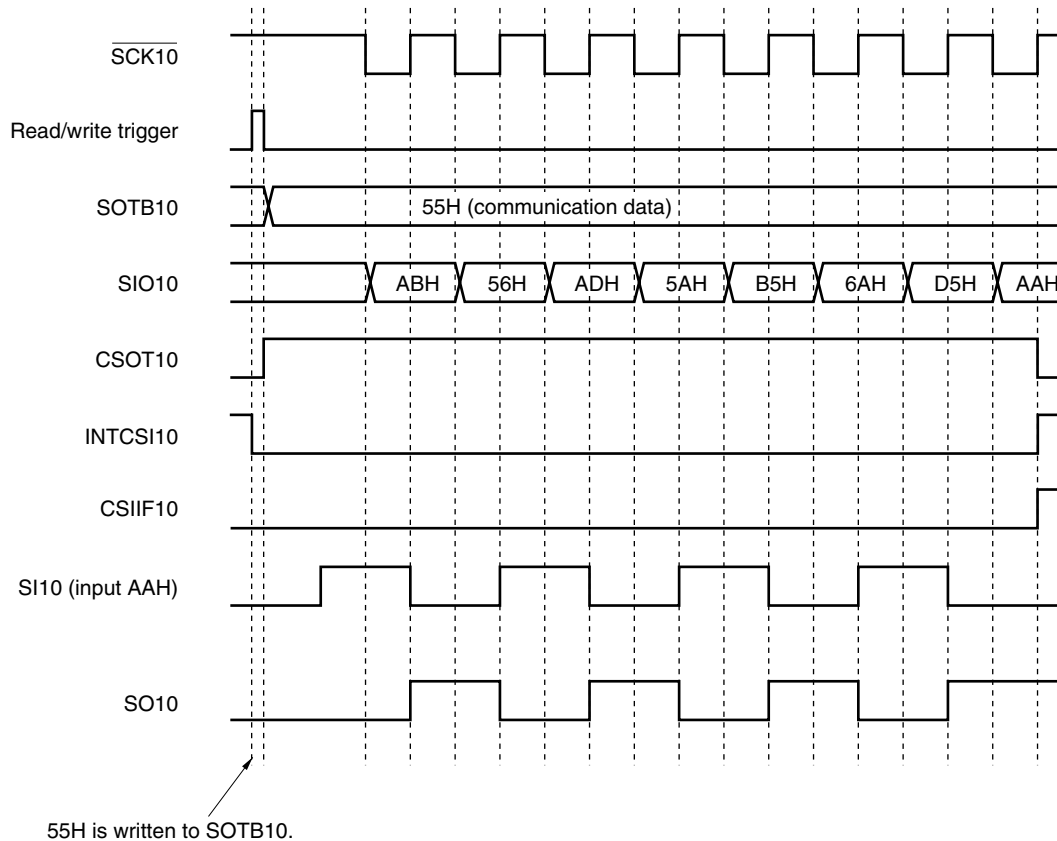
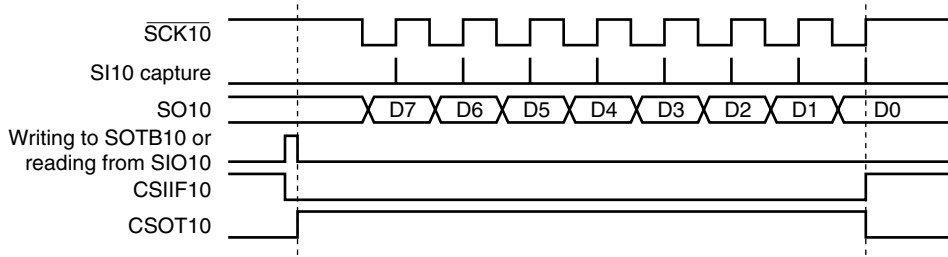
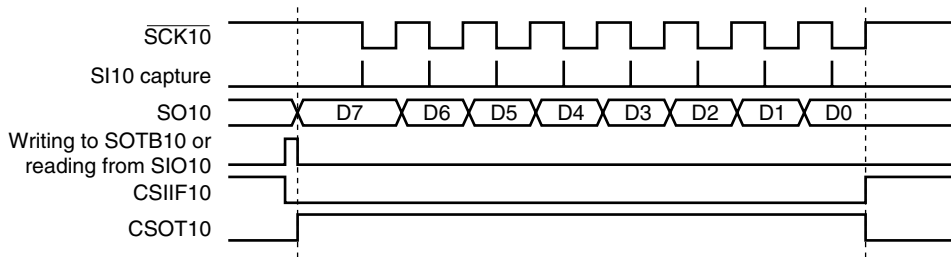

Figure 13-6. Timing of Clock/Data Phase

(a) Type 1: CKP10 = 0, DAP10 = 0, DIR10 = 0



(b) Type 2: CKP10 = 0, DAP10 = 1, DIR10 = 0



(c) Type 3: CKP10 = 1, DAP10 = 0, DIR10 = 0

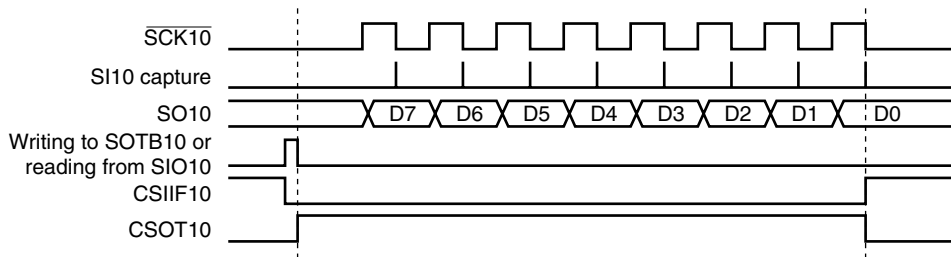

(d) Type 4: CKP10 = 1, DAP10 = 1, DIR10 = 0

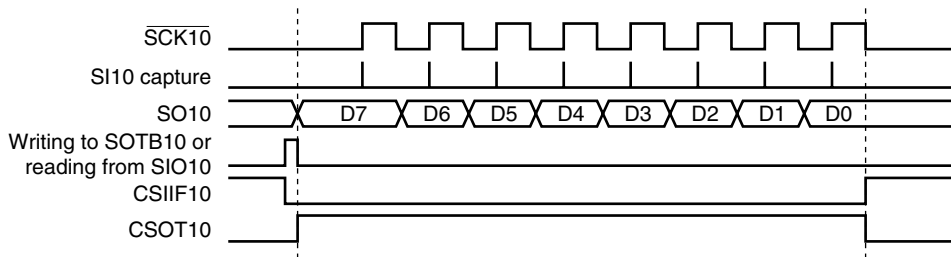

Remark The above figure illustrates a communication operation where data is transmitted with the MSB first.

(3) Timing of output to SO10 pin (first bit)

When communication is started, the value of transmit buffer register 10 (SOTB10) is output from the SO10 pin. The output operation of the first bit at this time is described below.

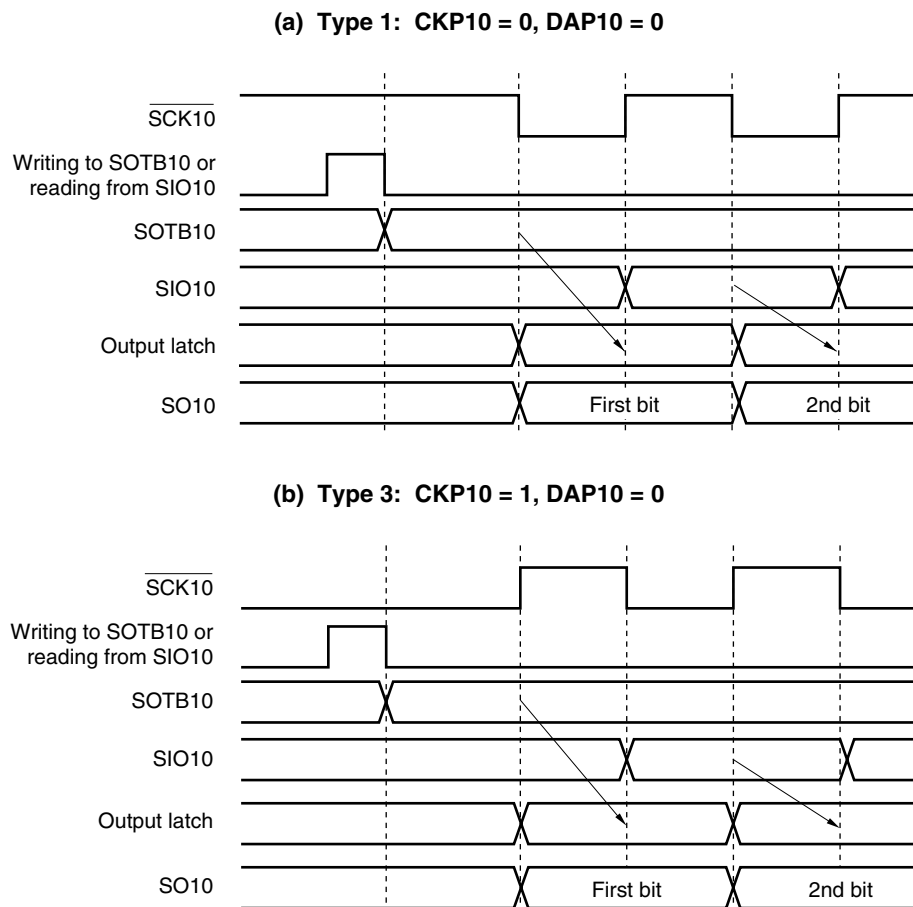
Figure 13-7. Output Operation of First Bit (1/2)

The first bit is directly latched by the SOTB10 register to the output latch at the falling (or rising) edge of $\overline{\text{SCK10}}$, and output from the SO10 pin via an output selector. Then, the value of the SOTB10 register is transferred to the SIO10 register at the next rising (or falling) edge of $\overline{\text{SCK10}}$, and shifted one bit. At the same time, the first bit of the receive data is stored in the SIO10 register via the SI10 pin.

The second and subsequent bits are latched by the SIO10 register to the output latch at the next falling (or rising) edge of $\overline{\text{SCK10}}$, and the data is output from the SO10 pin.

Figure 13-7. Output Operation of First Bit (2/2)

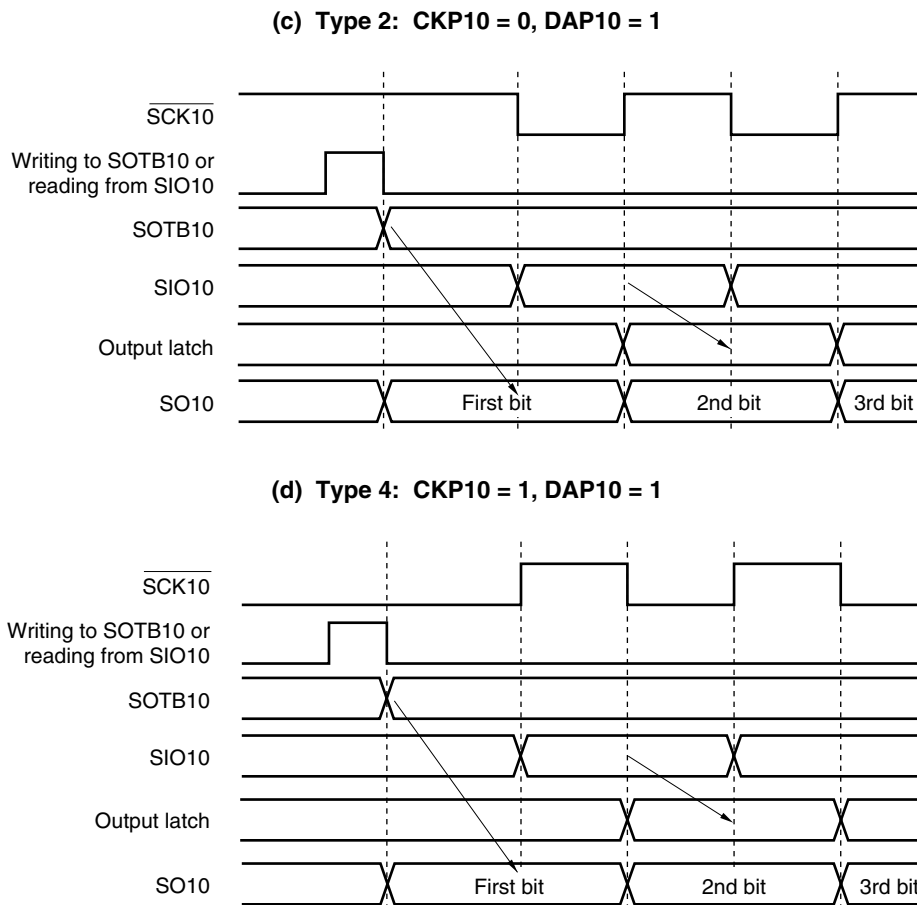

The first bit is directly latched by the SOTB10 register at the falling edge of the write signal of the SOTB10 register or the read signal of the SIO10 register, and output from the SO10 pin via an output selector. Then, the value of the SOTB10 register is transferred to the SIO10 register at the next falling (or rising) edge of $\overline{\text{SCK10}}$, and shifted one bit. At the same time, the first bit of the receive data is stored in the SIO10 register via the SI10 pin. The second and subsequent bits are latched by the SIO10 register to the output latch at the next rising (or falling) edge of $\overline{\text{SCK10}}$, and the data is output from the SO10 pin.

(4) Output value of SO10 pin (last bit)

After communication has been completed, the SO10 pin holds the output value of the last bit.

Figure 13-8. Output Value of SO10 Pin (Last Bit) (1/2)

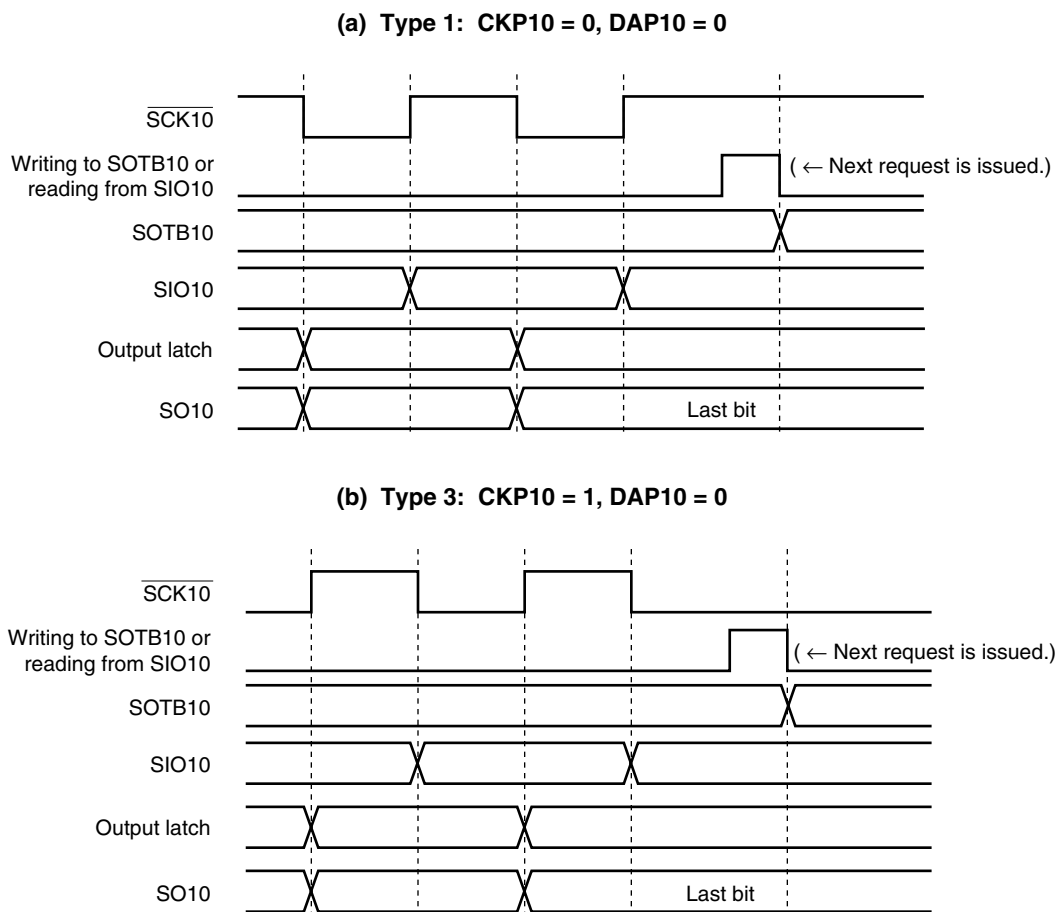
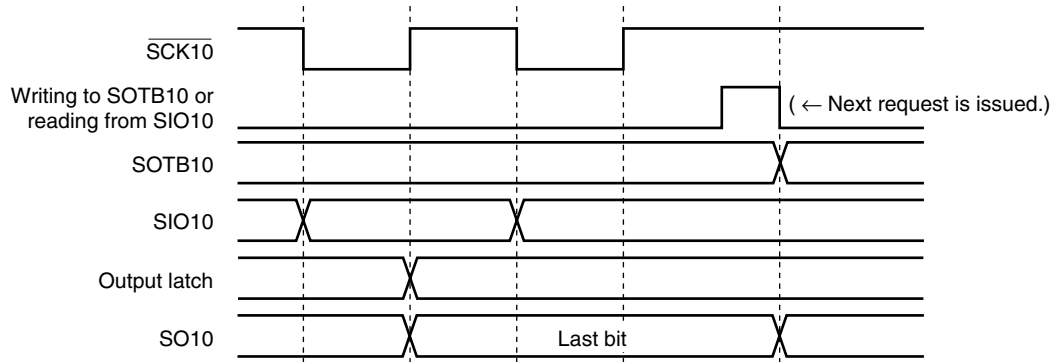
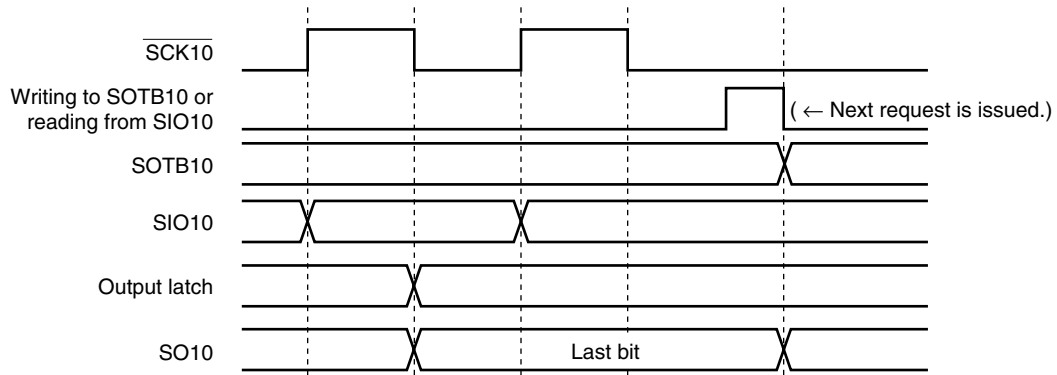

Figure 13-8. Output Value of SO10 Pin (Last Bit) (2/2)

(c) Type 2: CKP10 = 0, DAP10 = 1



(d) Type 4: CKP10 = 1, DAP10 = 1



(5) SO10 output (see (a) in Figures 13-1)

The status of the SO10 output is as follows if bit 7 (CSIE10) of serial operation mode register 10 (CSIM10) is cleared to 0.

Table 13-3. SO10 Output Status

TRMD10	DAP10	DIR10	SO10 Output ^{Note 1}
TRMD10 = 0 ^{Note 2}	–	–	Outputs low level ^{Note 2}
TRMD10 = 1	DAP10 = 0	–	Value of SO10 latch (low-level output)
	DAP10 = 1	DIR10 = 0	Value of bit 7 of SOTB10
		DIR10 = 1	Value of bit 0 of SOTB10

- Notes**
1. The actual output of the SO10/P12 pin is determined according to PM12 and P12, as well as the SO10 output.
 2. Status after reset

Caution If a value is written to TRMD10, DAP10, and DIR10, the output value of SO10 changes.

CHAPTER 14 SERIAL INTERFACE IIC0

14.1 Functions of Serial Interface IIC0

Serial interface IIC0 has the following two modes.

(1) Operation stop mode

This mode is used when serial transfers are not performed. It can therefore be used to reduce power consumption.

(2) I²C bus mode (multimaster supported)

This mode is used for 8-bit data transfers with several devices via two lines: a serial clock (SCL0) line and a serial data bus (SDA0) line.

This mode complies with the I²C bus format and the master device can generate “start condition”, “address”, “transfer direction specification”, “data”, and “stop condition” data to the slave device, via the serial data bus. The slave device automatically detects these received status and data by hardware. This function can simplify the part of application program that controls the I²C bus.

Since the SCL0 and SDA0 pins are used for open drain outputs, IIC0 requires pull-up resistors for the serial clock line and the serial data bus line.

Figure 14-1 shows a block diagram of serial interface IIC0.

Figure 14-1. Block Diagram of Serial Interface IIC0

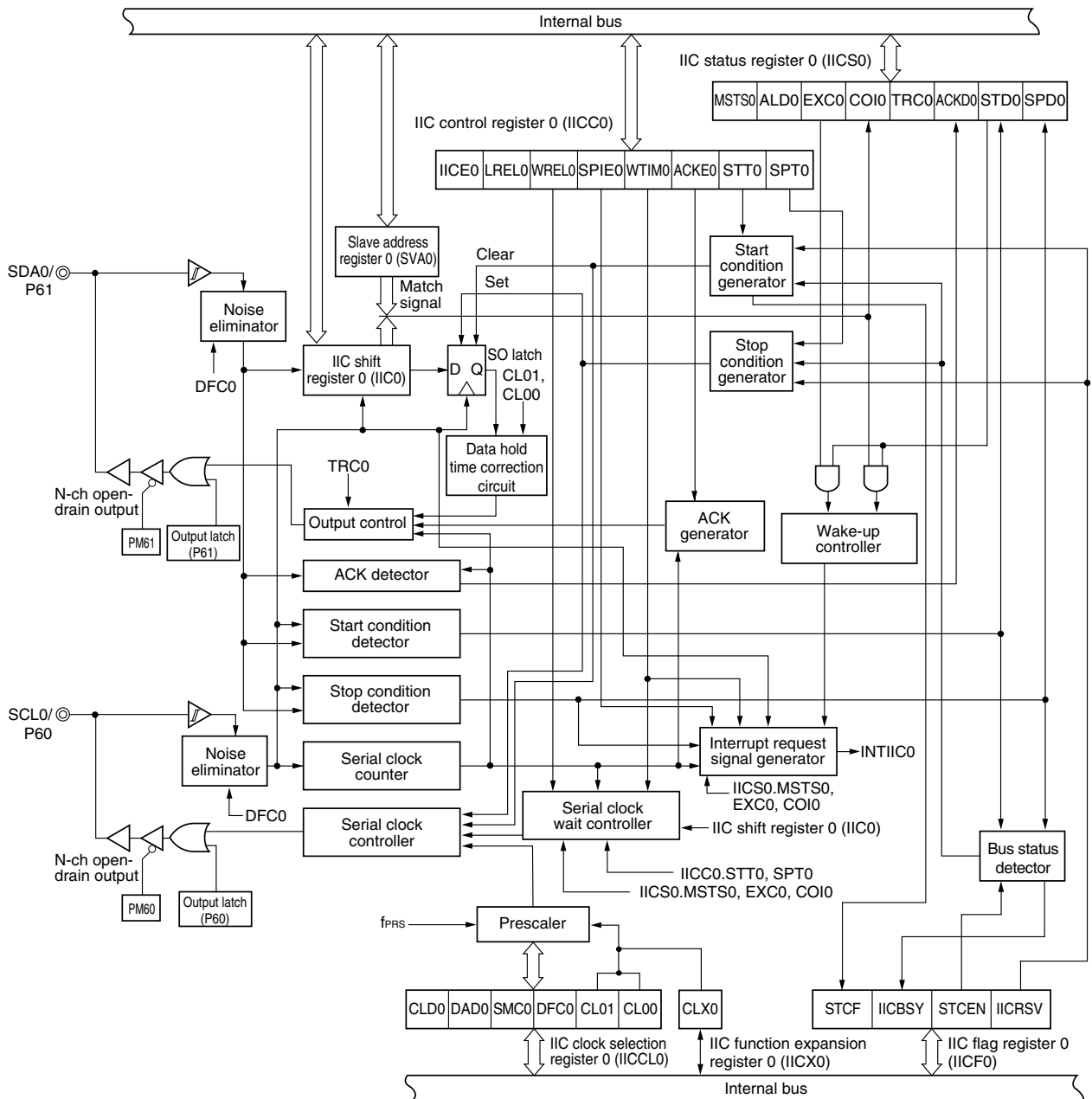
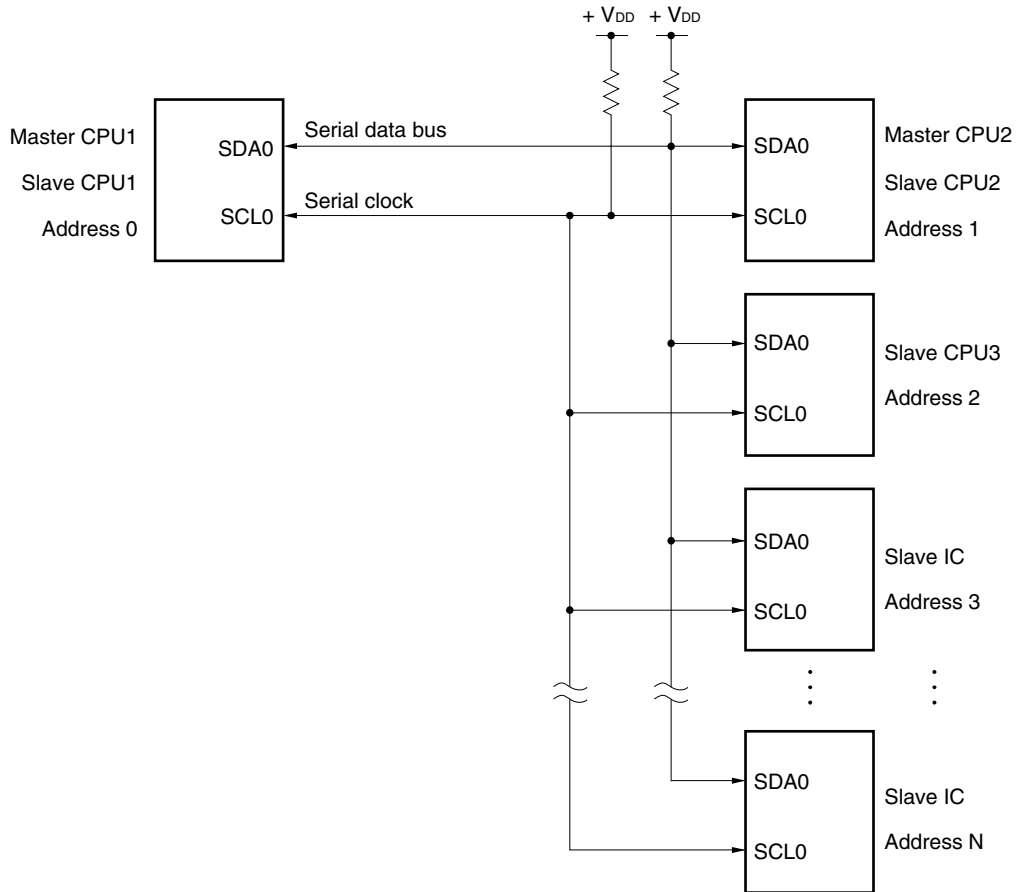

Figure 14-2 shows a serial bus configuration example.

Figure 14-2. Serial Bus Configuration Example Using I²C Bus



14.2 Configuration of Serial Interface IIC0

Serial interface IIC0 includes the following hardware.

Table 14-1. Configuration of Serial Interface IIC0

Item	Configuration
Registers	IIC shift register 0 (IIC0) Slave address register 0 (SVA0)
Control registers	IIC control register 0 (IICC0) IIC status register 0 (IICSO) IIC flag register 0 (IICF0) IIC clock selection register 0 (IICCL0) IIC function expansion register 0 (IICX0) Port mode register 6 (PM6) Port register 6 (P6)

(1) IIC shift register 0 (IIC0)

IIC0 is used to convert 8-bit serial data to 8-bit parallel data and vice versa in synchronization with the serial clock. IIC0 can be used for both transmission and reception.

The actual transmit and receive operations can be controlled by writing and reading operations to IIC0.

Cancel the wait state and start data transfer by writing data to IIC0 during the wait period.

IIC0 is set by an 8-bit memory manipulation instruction.

Reset signal generation sets IIC0 to 00H.

Figure 14-3. Format of IIC Shift Register 0 (IIC0)

Address: FFA5H After reset: 00H R/W

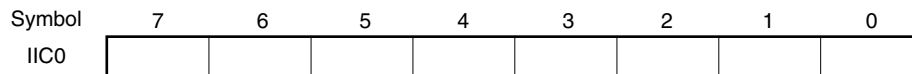

Cautions 1. Do not write data to IIC0 during data transfer.

2. Write or read IIC0 only during the wait period. Accessing IIC0 in a communication state other than during the wait period is prohibited. When the device serves as the master, however, IIC0 can be written only once after the communication trigger bit (STT0) is set to 1.

(2) Slave address register 0 (SVA0)

This register stores local addresses when in slave mode.

SVA0 is set by an 8-bit memory manipulation instruction.

However, rewriting to this register is prohibited while STD0 = 1 (while the start condition is detected).

Reset signal generation sets SVA0 to 00H.

Figure 14-4. Format of Slave Address Register 0 (SVA0)

Address: FFA7H After reset: 00H R/W

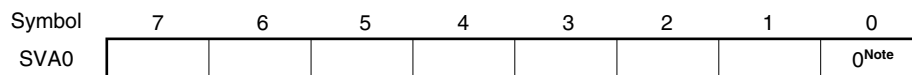

Note Bit 0 is fixed to 0.

(3) SO latch

The SO latch is used to retain the SDA0 pin's output level.

(4) Wake-up controller

This circuit generates an interrupt request (INTIIC0) when the address received by this register matches the address value set to slave address register 0 (SVA0) or when an extension code is received.

(5) Prescaler

This selects the sampling clock to be used.

(6) Serial clock counter

This counter counts the serial clocks that are output or input during transmit/receive operations and is used to verify that 8-bit data was transmitted or received.

(7) Interrupt request signal generator

This circuit controls the generation of interrupt request signals (INTIIC0).

An I²C interrupt request is generated by the following two triggers.

- Falling edge of eighth or ninth clock of the serial clock (set by WTIMO bit)
- Interrupt request generated when a stop condition is detected (set by SPIE0 bit)

Remark WTIMO bit: Bit 3 of IIC control register 0 (IICC0)

SPIE0 bit: Bit 4 of IIC control register 0 (IICC0)

(8) Serial clock controller

In master mode, this circuit generates the clock output via the SCL0 pin from a sampling clock.

(9) Serial clock wait controller

This circuit controls the wait timing.

(10) ACK generator, stop condition detector, start condition detector, and ACK detector

These circuits generate and detect each status.

(11) Data hold time correction circuit

This circuit generates the hold time for data corresponding to the falling edge of the serial clock.

(12) Start condition generator

This circuit generates a start condition when the STT0 bit is set to 1.

However, in the communication reservation disabled status (IICRSV bit = 1), when the bus is not released (IICBSY bit = 1), start condition requests are ignored and the STCF bit is set to 1.

(13) Stop condition generator

This circuit generates a stop condition when the SPT0 bit is set to 1.

(14) Bus status detector

This circuit detects whether or not the bus is released by detecting start conditions and stop conditions. However, as the bus status cannot be detected immediately following operation, the initial status is set by the STCEN bit.

Remark STT0 bit: Bit 1 of IIC control register 0 (IICC0)
SPT0 bit: Bit 0 of IIC control register 0 (IICC0)
IICRSV bit: Bit 0 of IIC flag register 0 (IICF0)
IICBSY bit: Bit 6 of IIC flag register 0 (IICF0)
STCF bit: Bit 7 of IIC flag register 0 (IICF0)
STCEN bit: Bit 1 of IIC flag register 0 (IICF0)

14.3 Registers to Control Serial Interface IIC0

Serial interface IIC0 is controlled by the following seven registers.

- IIC control register 0 (IICC0)
- IIC flag register 0 (IICF0)
- IIC status register 0 (IICS0)
- IIC clock selection register 0 (IICCL0)
- IIC function expansion register 0 (IICX0)
- Port mode register 6 (PM6)
- Port register 6 (P6)

(1) IIC control register 0 (IICC0)

This register is used to enable/stop I²C operations, set wait timing, and set other I²C operations.

IICC0 is set by a 1-bit or 8-bit memory manipulation instruction. However, set the SPIE0, WTIM0, and ACKE0 bits while IICE0 bit = 0 or during the wait period. These bits can be set at the same time when the IICE0 bit is set from “0” to “1”.

Reset signal generation sets IICC0 to 00H.

Figure 14-5. Format of IIC Control Register 0 (IICC0) (1/4)

Address: FFA6H After reset: 00H R/W

Symbol	<7>	<6>	<5>	<4>	<3>	<2>	<1>	<0>
IICC0	IICE0	LRELO	WRELO	SPIE0	WTIM0	ACKE0	STT0	SPT0

IICE0	I ² C operation enable
0	Stop operation. Reset IIC status register 0 (IICS0) ^{Note 1} . Stop internal operation.
1	Enable operation.
Be sure to set this bit (1) while the SCL0 and SDA0 lines are at high level.	
Condition for clearing (IICE0 = 0)	
Condition for setting (IICE0 = 1)	
<ul style="list-style-type: none"> • Cleared by instruction • Reset 	<ul style="list-style-type: none"> • Set by instruction

LRELO ^{Note 2}	Exit from communications
0	Normal operation
1	This exits from the current communications and sets standby mode. This setting is automatically cleared to 0 after being executed. Its uses include cases in which a locally irrelevant extension code has been received. The SCL0 and SDA0 lines are set to high impedance. The following flags of IIC control register 0 (IICC0) and IIC status register 0 (IICS0) are cleared to 0. • STT0 • SPT0 • MSTS0 • EXC0 • COI0 • TRC0 • ACKD0 • STD0
The standby mode following exit from communications remains in effect until the following communications entry conditions are met.	
<ul style="list-style-type: none"> • After a stop condition is detected, restart is in master mode. • An address match or extension code reception occurs after the start condition. 	
Condition for clearing (LRELO = 0)	
Condition for setting (LRELO = 1)	
<ul style="list-style-type: none"> • Automatically cleared after execution • Reset 	<ul style="list-style-type: none"> • Set by instruction

WRELO ^{Note 2}	Wait cancellation
0	Do not cancel wait
1	Cancel wait. This setting is automatically cleared after wait is canceled.
When WRELO is set (wait canceled) during the wait period at the ninth clock pulse in the transmission status (TRC0 = 1), the SDA0 line goes into the high impedance state (TRC0 = 0).	
Condition for clearing (WRELO = 0)	
Condition for setting (WRELO = 1)	
<ul style="list-style-type: none"> • Automatically cleared after execution • Reset 	<ul style="list-style-type: none"> • Set by instruction

- Notes 1.** The IICS0 register, the STCF0 and IICBSY bits of the IICF0 register, and the CLD0 and DAD0 bits of the IICCL0 register are reset.
- 2.** This flag's signal is invalid when IICE0 = 0.

Caution The start condition is detected immediately after I²C is enabled to operate (IICE0 = 1) while the SCL0 line is at high level and the SDA0 line is at low level. Immediately after enabling I²C to operate (IICE0 = 1), set LRELO (1) by using a 1-bit memory manipulation instruction.

Figure 14-5. Format of IIC Control Register 0 (IICC0) (2/4)

SPIE0 ^{Note 1}	Enable/disable generation of interrupt request when stop condition is detected	
0	Disable	
1	Enable	
Condition for clearing (SPIE0 = 0)		Condition for setting (SPIE0 = 1)
<ul style="list-style-type: none"> • Cleared by instruction • Reset 		<ul style="list-style-type: none"> • Set by instruction

WTIM0 ^{Note 1}	Control of wait and interrupt request generation	
0	Interrupt request is generated at the eighth clock's falling edge. Master mode: After output of eight clocks, clock output is set to low level and wait is set. Slave mode: After input of eight clocks, the clock is set to low level and wait is set for master device.	
1	Interrupt request is generated at the ninth clock's falling edge. Master mode: After output of nine clocks, clock output is set to low level and wait is set. Slave mode: After input of nine clocks, the clock is set to low level and wait is set for master device.	
An interrupt is generated at the falling edge of the ninth clock during address transfer independently of the setting of this bit. The setting of this bit is valid when the address transfer is completed. When in master mode, a wait is inserted at the falling edge of the ninth clock during address transfers. For a slave device that has received a local address, a wait is inserted at the falling edge of the ninth clock after an acknowledge (\overline{ACK}) is issued. However, when the slave device has received an extension code, a wait is inserted at the falling edge of the eighth clock.		
Condition for clearing (WTIM0 = 0)		Condition for setting (WTIM0 = 1)
<ul style="list-style-type: none"> • Cleared by instruction • Reset 		<ul style="list-style-type: none"> • Set by instruction

ACKE0 ^{Notes 1, 2}	Acknowledgment control	
0	Disable acknowledgment.	
1	Enable acknowledgment. During the ninth clock period, the SDA0 line is set to low level. However, \overline{ACK} is invalid during address transfers and other than in expansion mode.	
Condition for clearing (ACKE0 = 0)		Condition for setting (ACKE0 = 1)
<ul style="list-style-type: none"> • Cleared by instruction • Reset 		<ul style="list-style-type: none"> • Set by instruction

Notes 1. This flag's signal is invalid when IICE0 = 0.

2. The set value is invalid during address transfer and if the code is not an extension code.

When the device serves as a slave and the addresses match, an acknowledge is generated regardless of the set value.

Figure 14-5. Format of IIC Control Register 0 (IICC0) (3/4)

STT0 ^{Note}	Start condition trigger	
0	Do not generate a start condition.	
1	<p>When bus is released (in STOP mode): Generate a start condition (for starting as master). When the SCL0 line is high level, the SDA0 line is changed from high level to low level and then the start condition is generated. Next, after the rated amount of time has elapsed, SCL0 is changed to low level (wait state).</p> <p>When a third party is communicating:</p> <ul style="list-style-type: none"> • When communication reservation function is enabled (IICRSV = 0) Functions as the start condition reservation flag. When set to 1, automatically generates a start condition after the bus is released. • When communication reservation function is disabled (IICRSV = 1) STCF is set to 1 and information that is set (1) to STT0 is cleared. No start condition is generated. <p>In the wait state (when master device): Generates a restart condition after releasing the wait.</p>	
<p>Cautions concerning set timing</p> <ul style="list-style-type: none"> • For master reception: Cannot be set to 1 during transfer. Can be set to 1 only in the waiting period when ACKE0 has been cleared to 0 and slave has been notified of final reception. • For master transmission: A start condition cannot be generated normally during the acknowledge period. Set to 1 during the wait period that follows output of the ninth clock. • Cannot be set to 1 at the same time as SPT0. • Setting STT0 to 1 and then setting it again before it is cleared to 0 is prohibited. 		
Condition for clearing (STT0 = 0)		Condition for setting (STT0 = 1)
<ul style="list-style-type: none"> • Cleared by setting SST0 to 1 while communication reservation is prohibited. • Cleared by loss in arbitration • Cleared after start condition is generated by master device • Cleared by LREL0 = 1 (exit from communications) • When IICE0 = 0 (operation stop) • Reset 		<ul style="list-style-type: none"> • Set by instruction

Note This flag's signal is invalid when IICE0 = 0.

Remarks 1. Bit 1 (STT0) becomes 0 when it is read after data setting.

2. IICRSV: Bit 0 of IIC flag register (IICF0)

STCF: Bit 7 of IIC flag register (IICF0)

Figure 14-5. Format of IIC Control Register 0 (IICC0) (4/4)

SPT0	Stop condition trigger	
0	Stop condition is not generated.	
1	Stop condition is generated (termination of master device's transfer). After the SDA0 line goes to low level, either set the SCL0 line to high level or wait until it goes to high level. Next, after the rated amount of time has elapsed, the SDA0 line changes from low level to high level and a stop condition is generated.	
Cautions concerning set timing <ul style="list-style-type: none"> • For master reception: Cannot be set to 1 during transfer. Can be set to 1 only in the waiting period when ACKE0 has been cleared to 0 and slave has been notified of final reception. • For master transmission: A stop condition cannot be generated normally during the acknowledge period. Therefore, set it during the wait period that follows output of the ninth clock. • Cannot be set to 1 at the same time as STT0. • SPT0 can be set to 1 only when in master mode^{Note}. • When WTIM0 has been cleared to 0, if SPT0 is set to 1 during the wait period that follows output of eight clocks, note that a stop condition will be generated during the high-level period of the ninth clock. WTIM0 should be changed from 0 to 1 during the wait period following the output of eight clocks, and SPT0 should be set to 1 during the wait period that follows the output of the ninth clock. • Setting SPT0 to 1 and then setting it again before it is cleared to 0 is prohibited. 		
Condition for clearing (SPT0 = 0)		Condition for setting (SPT0 = 1)
<ul style="list-style-type: none"> • Cleared by loss in arbitration • Automatically cleared after stop condition is detected • Cleared by LREL0 = 1 (exit from communications) • When IICE0 = 0 (operation stop) • Reset 		<ul style="list-style-type: none"> • Set by instruction

Note Set SPT0 to 1 only in master mode. However, SPT0 must be set to 1 and a stop condition generated before the first stop condition is detected following the switch to the operation enabled status. For details, see **14.5.15 Other cautions.**

Caution When bit 3 (TRC0) of IIC status register 0 (IICS0) is set to 1, WREL0 is set to 1 during the ninth clock and wait is canceled, after which TRC0 is cleared and the SDA0 line is set to high impedance.

Remark Bit 0 (SPT0) becomes 0 when it is read after data setting.

(2) IIC status register 0 (IICS0)

This register indicates the status of I²C.

IICS0 is read by a 1-bit or 8-bit memory manipulation instruction only when STT0 = 1 and during the wait period.

Reset signal generation sets IICS0 to 00H.

Caution If data is read from IICS0, a wait cycle is generated. For details, see CHAPTER 26 CAUTIONS FOR WAIT.

Figure 14-6. Format of IIC Status Register 0 (IICS0) (1/3)

Address: FFAAH After reset: 00H R

Symbol	<7>	<6>	<5>	<4>	<3>	<2>	<1>	<0>
IICS0	MSTS0	ALD0	EXC0	COI0	TRC0	ACKD0	STD0	SPD0

MSTS0	Master device status	
0	Slave device status or communication standby status	
1	Master device communication status	
Condition for clearing (MSTS0 = 0)		Condition for setting (MSTS0 = 1)
<ul style="list-style-type: none"> • When a stop condition is detected • When ALD0 = 1 (arbitration loss) • Cleared by LREL0 = 1 (exit from communications) • When IICE0 changes from 1 to 0 (operation stop) • Reset 		<ul style="list-style-type: none"> • When a start condition is generated

ALD0	Detection of arbitration loss	
0	This status means either that there was no arbitration or that the arbitration result was a "win".	
1	This status indicates the arbitration result was a "loss". MSTS0 is cleared.	
Condition for clearing (ALD0 = 0)		Condition for setting (ALD0 = 1)
<ul style="list-style-type: none"> • Automatically cleared after IICS0 is read^{Note} • When IICE0 changes from 1 to 0 (operation stop) • Reset 		<ul style="list-style-type: none"> • When the arbitration result is a "loss".

EXC0	Detection of extension code reception	
0	Extension code was not received.	
1	Extension code was received.	
Condition for clearing (EXC0 = 0)		Condition for setting (EXC0 = 1)
<ul style="list-style-type: none"> • When a start condition is detected • When a stop condition is detected • Cleared by LREL0 = 1 (exit from communications) • When IICE0 changes from 1 to 0 (operation stop) • Reset 		<ul style="list-style-type: none"> • When the higher four bits of the received address data is either "0000" or "1111" (set at the rising edge of the eighth clock).

Note This register is also cleared when a 1-bit memory manipulation instruction is executed for bits other than IICS0. Therefore, when using the ALD0 bit, read the data of this bit before the data of the other bits.

Remark LREL0: Bit 6 of IIC control register 0 (IICC0)
 IICE0: Bit 7 of IIC control register 0 (IICC0)

Figure 14-6. Format of IIC Status Register 0 (IICS0) (2/3)

COI0	Detection of matching addresses	
0	Addresses do not match.	
1	Addresses match.	
Condition for clearing (COI0 = 0)		Condition for setting (COI0 = 1)
<ul style="list-style-type: none"> • When a start condition is detected • When a stop condition is detected • Cleared by LREL0 = 1 (exit from communications) • When IICE0 changes from 1 to 0 (operation stop) • Reset 		<ul style="list-style-type: none"> • When the received address matches the local address (slave address register 0 (SVA0)) (set at the rising edge of the eighth clock).

TRC0	Detection of transmit/receive status	
0	Receive status (other than transmit status). The SDA0 line is set for high impedance.	
1	Transmit status. The value in the SO0 latch is enabled for output to the SDA0 line (valid starting at the falling edge of the first byte's ninth clock).	
Condition for clearing (TRC0 = 0)		Condition for setting (TRC0 = 1)
<Both master and slave> <ul style="list-style-type: none"> • When a stop condition is detected • Cleared by LREL0 = 1 (exit from communications) • When IICE0 changes from 1 to 0 (operation stop) • Cleared by WREL0 = 1^{Note} (wait cancel) • When ALD0 changes from 0 to 1 (arbitration loss) • Reset <Master> <ul style="list-style-type: none"> • When "1" is output to the first byte's LSB (transfer direction specification bit) <Slave> <ul style="list-style-type: none"> • When a start condition is detected • When "0" is input to the first byte's LSB (transfer direction specification bit) <When not used for communication>		<Master> <ul style="list-style-type: none"> • When a start condition is generated • When "0" is output to the first byte's LSB (transfer direction specification bit) <Slave> <ul style="list-style-type: none"> • When "1" is input to the first byte's LSB (transfer direction specification bit)

Note If the wait status is canceled by setting bit 5 (WREL0) of IIC control register 0 (IICC0) to 1 at the ninth clock when bit 3 (TRC0) of IIC status register 0 (IICS0) is 1, TRC0 is cleared, and the SDA0 line goes into a high-impedance state.

Remark LREL0: Bit 6 of IIC control register 0 (IICC0)
IICE0: Bit 7 of IIC control register 0 (IICC0)

Figure 14-6. Format of IIC Status Register 0 (IICS0) (3/3)

ACKD0	Detection of acknowledge ($\overline{\text{ACK}}$)	
0	Acknowledge was not detected.	
1	Acknowledge was detected.	
Condition for clearing (ACKD0 = 0)		Condition for setting (ACKD0 = 1)
<ul style="list-style-type: none"> • When a stop condition is detected • At the rising edge of the next byte's first clock • Cleared by LREL0 = 1 (exit from communications) • When IICE0 changes from 1 to 0 (operation stop) • Reset 		<ul style="list-style-type: none"> • After the SDA0 line is set to low level at the rising edge of SCL0's ninth clock

STD0	Detection of start condition	
0	Start condition was not detected.	
1	Start condition was detected. This indicates that the address transfer period is in effect.	
Condition for clearing (STD0 = 0)		Condition for setting (STD0 = 1)
<ul style="list-style-type: none"> • When a stop condition is detected • At the rising edge of the next byte's first clock following address transfer • Cleared by LREL0 = 1 (exit from communications) • When IICE0 changes from 1 to 0 (operation stop) • Reset 		<ul style="list-style-type: none"> • When a start condition is detected

SPD0	Detection of stop condition	
0	Stop condition was not detected.	
1	Stop condition was detected. The master device's communication is terminated and the bus is released.	
Condition for clearing (SPD0 = 0)		Condition for setting (SPD0 = 1)
<ul style="list-style-type: none"> • At the rising edge of the address transfer byte's first clock following setting of this bit and detection of a start condition • When IICE0 changes from 1 to 0 (operation stop) • Reset 		<ul style="list-style-type: none"> • When a stop condition is detected

Remark LREL0: Bit 6 of IIC control register 0 (IICC0)

IICE0: Bit 7 of IIC control register 0 (IICC0)

(3) IIC flag register 0 (IICF0)

This register sets the operation mode of I²C and indicates the status of the I²C bus.

IICF0 is set by a 1-bit or 8-bit memory manipulation instruction. However, the STCF and IICBSY bits are read-only.

The IICRSV bit can be used to enable/disable the communication reservation function (see **14.5.14 Communication reservation**).

STCEN can be used to set the initial value of the IICBSY bit (see **14.5.15 Other cautions**).

IICRSV and STCEN can be written only when the operation of I²C is disabled (bit 7 (IICE0) of IIC control register 0 (IICC0) = 0). When operation is enabled, the IICF0 register can be read.

Reset signal generation sets IICF0 to 00H.

Figure 14-7. Format of IIC Flag Register 0 (IICF0)

Address: FFABH After reset: 00H R/W^{Note}

Symbol	<7>	<6>	5	4	3	2	<1>	<0>
IICF0	STCF	IICBSY	0	0	0	0	STCEN	IICRSV

STCF	STT0 clear flag
0	Generate start condition
1	Start condition generation unsuccessful: clear STT0 flag
Condition for clearing (STCF = 0)	
<ul style="list-style-type: none"> • Cleared by STT0 = 1 • When IICE0 = 0 (operation stop) • Reset 	
Condition for setting (STCF = 1)	
<ul style="list-style-type: none"> • Generating start condition unsuccessful and STT0 cleared to 0 when communication reservation is disabled (IICRSV = 1). 	

IICBSY	I ² C bus status flag
0	Bus release status (communication initial status when STCEN = 1)
1	Bus communication status (communication initial status when STCEN = 0)
Condition for clearing (IICBSY = 0)	
<ul style="list-style-type: none"> • Detection of stop condition • When IICE0 = 0 (operation stop) • Reset 	
Condition for setting (IICBSY = 1)	
<ul style="list-style-type: none"> • Detection of start condition • Setting of IICE0 when STCEN = 0 	

STCEN	Initial start enable trigger
0	After operation is enabled (IICE0 = 1), enable generation of a start condition upon detection of a stop condition.
1	After operation is enabled (IICE0 = 1), enable generation of a start condition without detecting a stop condition.
Condition for clearing (STCEN = 0)	
<ul style="list-style-type: none"> • Detection of start condition • Reset 	
Condition for setting (STCEN = 1)	
<ul style="list-style-type: none"> • Set by instruction 	

<R>

IICRSV	Communication reservation function disable bit
0	Enable communication reservation
1	Disable communication reservation
Condition for clearing (IICRSV = 0)	
<ul style="list-style-type: none"> • Cleared by instruction • Reset 	
Condition for setting (IICRSV = 1)	
<ul style="list-style-type: none"> • Set by instruction 	

Note Bits 6 and 7 are read-only.

- Cautions**
1. Write to STCEN only when the operation is stopped (IICE0 = 0).
 2. As the bus release status (IICBSY = 0) is recognized regardless of the actual bus status when STCEN = 1, when generating the first start condition (STT0 = 1), it is necessary to verify that no third party communications are in progress in order to prevent such communications from being destroyed.
 3. Write to IICRSV only when the operation is stopped (IICE0 = 0).

Remark STT0: Bit 1 of IIC control register 0 (IICC0)
 IICE0: Bit 7 of IIC control register 0 (IICC0)

(4) IIC clock selection register 0 (IICCL0)

This register is used to set the transfer clock for the I²C bus.

IICCL0 is set by a 1-bit or 8-bit memory manipulation instruction. However, the CLD0 and DAD0 bits are read-only. The SMC0, CL01, and CL00 bits are set in combination with bit 0 (CLX0) of IIC function expansion register 0 (IICX0) (see **14.3 (6) I²C transfer clock setting method**).

Set IICCL0 while bit 7 (IICE0) of IIC control register 0 (IICC0) is 0.

Reset signal generation sets IICCL0 to 00H.

Figure 14-8. Format of IIC Clock Selection Register 0 (IICCL0)

Address: FFA8H After reset: 00H R/W^{Note}

Symbol	7	6	<5>	<4>	<3>	<2>	1	0
IICCL0	0	0	CLD0	DAD0	SMC0	DFC0	CL01	CL00

CLD0	Detection of SCL0 pin level (valid only when IICE0 = 1)	
0	The SCL0 pin was detected at low level.	
1	The SCL0 pin was detected at high level.	
Condition for clearing (CLD0 = 0)		
<ul style="list-style-type: none"> • When the SCL0 pin is at low level • When IICE0 = 0 (operation stop) • Reset 		
Condition for setting (CLD0 = 1)		
<ul style="list-style-type: none"> • When the SCL0 pin is at high level 		

DAD0	Detection of SDA0 pin level (valid only when IICE0 = 1)	
0	The SDA0 pin was detected at low level.	
1	The SDA0 pin was detected at high level.	
Condition for clearing (DAD0 = 0)		
<ul style="list-style-type: none"> • When the SDA0 pin is at low level • When IICE0 = 0 (operation stop) • Reset 		
Condition for setting (DAD0 = 1)		
<ul style="list-style-type: none"> • When the SDA0 pin is at high level 		

SMC0	Operation mode switching	
0	Operates in standard mode.	
1	Operates in high-speed mode.	

DFC0	Digital filter operation control	
0	Digital filter off.	
1	Digital filter on.	
Digital filter can be used only in high-speed mode. In high-speed mode, the transfer clock does not vary regardless of DFC0 bit set (1)/clear (0). The digital filter is used for noise elimination in high-speed mode.		

Note Bits 4 and 5 are read-only.

Remark IICE0: Bit 7 of IIC control register 0 (IICC0)

(5) IIC function expansion register 0 (IICX0)

This register sets the function expansion of I²C.

IICX0 is set by a 1-bit or 8-bit memory manipulation instruction. The CLX0 bit is set in combination with bits 3, 1, and 0 (SMC0, CL01, and CL00) of IIC clock selection register 0 (IICCL0) (see **14.3 (6) I²C transfer clock setting method**).

Set IICX0 while bit 7 (IICE0) of IIC control register 0 (IICCC0) is 0.

Reset signal generation sets IICX0 to 00H.

Figure 14-9. Format of IIC Function Expansion Register 0 (IICX0)

Address: FFA9H	After reset: 00H	R/W						
Symbol	7	6	5	4	3	2	1	<0>
IICX0	0	0	0	0	0	0	0	CLX0

(6) I²C transfer clock setting method

The I²C transfer clock frequency (f_{SCL}) is calculated using the following expression.

$$f_{SCL} = 1/(m \times T + t_R + t_F)$$

$m = 12, 24, 44, 86$ (see **Table 14-2 Selection Clock Setting**)

$T: 1/f_w$

$t_R: SCL0$ rise time

$t_F: SCL0$ fall time

For example, the I²C transfer clock frequency (f_{SCL}) when $f_w = f_{PRS}/2 = 4.19$ MHz, $m = 86$, $t_R = 200$ ns, and $t_F = 50$ ns is calculated using following expression.

$$f_{SCL} = 1/(86 \times 238.7 \text{ ns} + 200 \text{ ns} + 50 \text{ ns}) \cong 48.1 \text{ kHz}$$

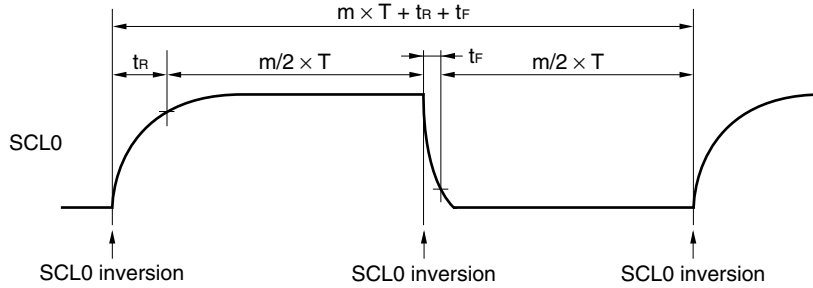

The selection clock is set using a combination of bits 3, 1, and 0 (SMC0, CL01, and CL00) of IIC clock selection register 0 (IICCL0) and bit 0 (CLX0) of IIC function expansion register 0 (IICX0).

Table 14-2. Selection Clock Setting

IICX0 Bit 0 CLX0	IICCL0			Selection Clock (f_w)	Transfer Clock (f_w/m)	Settable Selection Clock (f_w) Range	Operation Mode
	Bit 3 SMC0	Bit 1 CL01	Bit 0 CL00				
0	0	0	0	$f_{PRS}/2$	$f_w/44$	2.00 to 4.19 MHz	Normal mode (SMC0 bit = 0)
0	0	0	1	$f_{PRS}/2$	$f_w/86$	4.19 to 8.38 MHz	
0	0	1	0	$f_{PRS}/4$	$f_w/86$		
0	1	0	×	$f_{PRS}/2$	$f_w/24$	4.00 to 8.38 MHz	High-speed mode (SMC0 bit = 1)
0	1	1	0	$f_{PRS}/4$	$f_w/24$		
1	1	0	×	$f_{PRS}/2$	$f_w/12$	4.00 to 4.19 MHz	
1	1	1	0	$f_{PRS}/4$	$f_w/12$		
Other than above				Setting prohibited			

Caution Determine the transfer clock frequency of I²C by using CLX0, SMC0, CL01, and CL00 before enabling the operation (by setting bit 7 (IICE0) of IIC control register 0 (IICC0) to 1). To change the transfer clock frequency, clear IICE0 once to 0.

- Remarks**
1. ×: don't care
 2. f_{PRS} : Peripheral hardware clock frequency

(7) Port mode register 6 (PM6)

This register sets the input/output of port 6 in 1-bit units.

When using the P60/SCL0 pin as clock I/O and the P61/SDA0 pin as serial data I/O, clear PM60 and PM61, and the output latches of P60 and P61 to 0.

Set IICE0 (bit 7 of IIC control register 0 (IICC0)) to 1 before setting the output mode because the P60/SCL0 and P61/SDA0 pins output a low level (fixed) when IICE0 is 0.

PM6 is set by a 1-bit or 8-bit memory manipulation instruction.

Reset signal generation sets PM6 to FFH.

Figure 14-10. Format of Port Mode Register 6 (PM6)

Address: FF26H After reset: FFH R/W

Symbol	7	6	5	4	3	2	1	0
PM6	1	1	1	1	1	1	PM61	PM60

PM6n	P6n pin I/O mode selection (n = 0, 1)
0	Output mode (output buffer on)
1	Input mode (output buffer off)

14.4 I²C Bus Mode Functions

14.4.1 Pin configuration

The serial clock pin (SCL0) and serial data bus pin (SDA0) are configured as follows.

- (1) SCL0 This pin is used for serial clock input and output.
This pin is an N-ch open-drain output for both master and slave devices. Input is Schmitt input.
- (2) SDA0 This pin is used for serial data input and output.
This pin is an N-ch open-drain output for both master and slave devices. Input is Schmitt input.

Since outputs from the serial clock line and the serial data bus line are N-ch open-drain outputs, an external pull-up resistor is required.

Figure 14-11. Pin Configuration Diagram

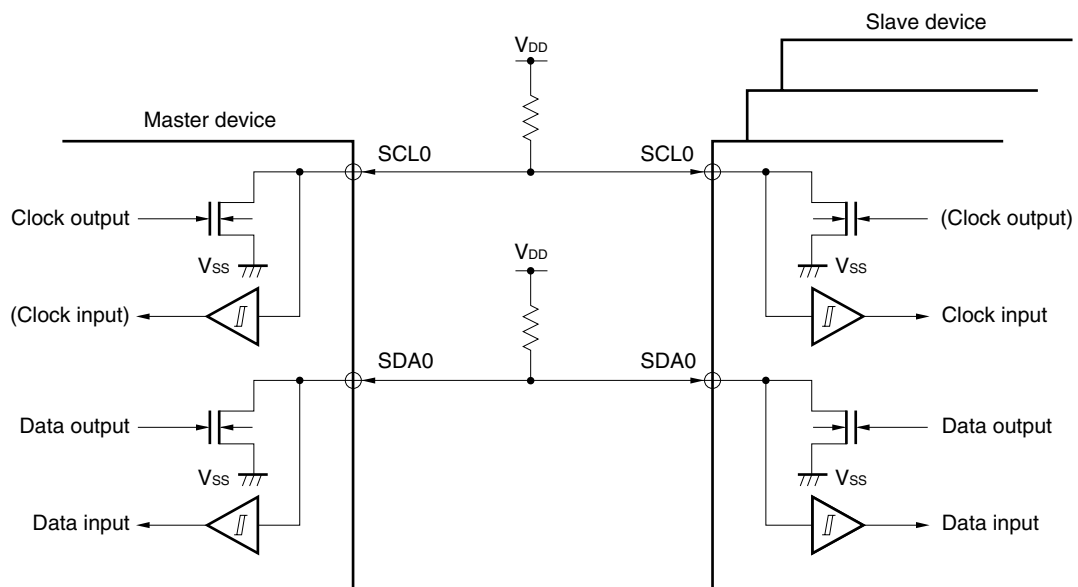

14.5 I²C Bus Definitions and Control Methods

The following section describes the I²C bus's serial data communication format and the signals used by the I²C bus. Figure 14-12 shows the transfer timing for the "start condition", "address", "data", and "stop condition" output via the I²C bus's serial data bus.

Figure 14-12. I²C Bus Serial Data Transfer Timing

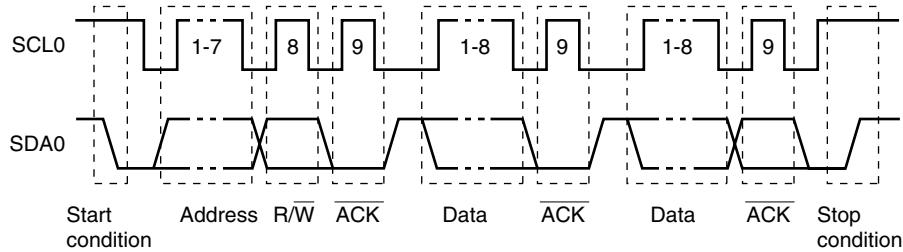

The master device generates the start condition, slave address, and stop condition.

The acknowledge ($\overline{\text{ACK}}$) can be generated by either the master or slave device (normally, it is output by the device that receives 8-bit data).

The serial clock (SCL0) is continuously output by the master device. However, in the slave device, the SCL0's low level period can be extended and a wait can be inserted.

14.5.1 Start conditions

A start condition is met when the SCL0 pin is at high level and the SDA0 pin changes from high level to low level. The start conditions for the SCL0 pin and SDA0 pin are signals that the master device generates to the slave device when starting a serial transfer. When the device is used as a slave, start conditions can be detected.

Figure 14-13. Start Conditions

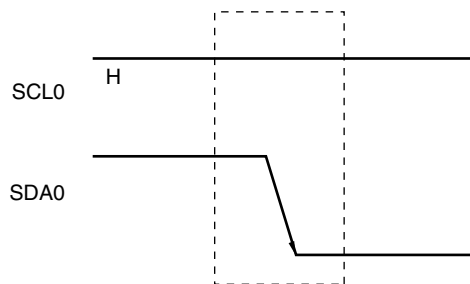

A start condition is output when bit 1 (STT0) of IIC control register 0 (IICC0) is set (to 1) after a stop condition has been detected (SPD0: Bit 0 = 1 in IIC status register 0 (IICS0)). When a start condition is detected, bit 1 (STD0) of IICS0 is set (to 1).

14.5.2 Addresses

The address is defined by the 7 bits of data that follow the start condition.

An address is a 7-bit data segment that is output in order to select one of the slave devices that are connected to the master device via the bus lines. Therefore, each slave device connected via the bus lines must have a unique address.

The slave devices include hardware that detects the start condition and checks whether or not the 7-bit address data matches the data values stored in slave address register 0 (SVA0). If the address data matches the SVA0 values, the slave device is selected and communicates with the master device until the master device generates a start condition or stop condition.

Figure 14-14. Address

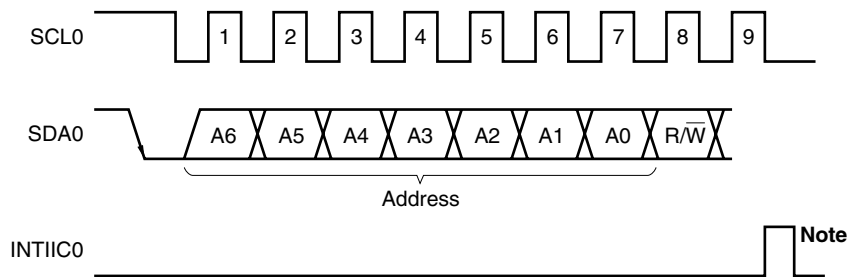

Note INTIIC0 is not issued if data other than a local address or extension code is received during slave device operation.

The slave address and the eighth bit, which specifies the transfer direction as described in **14.5.3 Transfer direction specification** below, are together written to IIC shift register 0 (IIC0) and are then output. Received addresses are written to IIC0.

The slave address is assigned to the higher 7 bits of IIC0.

14.5.3 Transfer direction specification

In addition to the 7-bit address data, the master device sends 1 bit that specifies the transfer direction.

When this transfer direction specification bit has a value of “0”, it indicates that the master device is transmitting data to a slave device. When the transfer direction specification bit has a value of “1”, it indicates that the master device is receiving data from a slave device.

Figure 14-15. Transfer Direction Specification

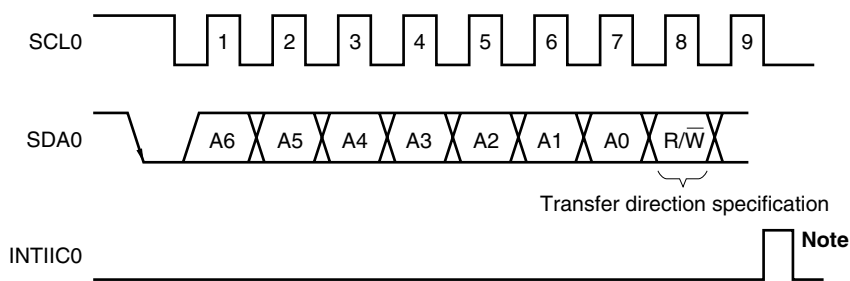

Note INTIIC0 is not issued if data other than a local address or extension code is received during slave device operation.

14.5.4 Acknowledge ($\overline{\text{ACK}}$)

$\overline{\text{ACK}}$ is used to check the status of serial data at the transmission and reception sides.

The reception side returns $\overline{\text{ACK}}$ each time it has received 8-bit data.

The transmission side usually receives $\overline{\text{ACK}}$ after transmitting 8-bit data. When $\overline{\text{ACK}}$ is returned from the reception side, it is assumed that reception has been correctly performed and processing is continued. Whether $\overline{\text{ACK}}$ has been detected can be checked by using bit 2 (ACKD0) of IIC status register 0 (IICS0).

When the master receives the last data item, it does not return $\overline{\text{ACK}}$ and instead generates a stop condition. If a slave does not return $\overline{\text{ACK}}$ after receiving data, the master outputs a stop condition or restart condition and stops transmission. If $\overline{\text{ACK}}$ is not returned, the possible causes are as follows.

- <1> Reception was not performed normally.
- <2> The final data item was received.
- <3> The reception side specified by the address does not exist.

To generate $\overline{\text{ACK}}$, the reception side makes the SDA0 line low at the ninth clock (indicating normal reception).

Automatic generation of $\overline{\text{ACK}}$ is enabled by setting bit 2 (ACKE0) of IIC control register 0 (IICC0) to 1. Bit 3 (TRC0) of the IICS0 register is set by the data of the eighth bit that follows 7-bit address information. Usually, set ACEK0 to 1 for reception (TRC0 = 0).

If a slave can receive no more data during reception (TRC0 = 0) or does not require the next data item, then the slave must inform the master, by clearing ACEK0 to 0, that it will not receive any more data.

When the master does not require the next data item during reception (TRC0 = 0), it must clear ACEK0 to 0 so that $\overline{\text{ACK}}$ is not generated. In this way, the master informs a slave at the transmission side that it does not require any more data (transmission will be stopped).

Figure 14-16. $\overline{\text{ACK}}$

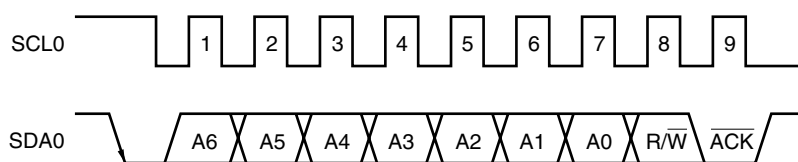

When the local address is received, $\overline{\text{ACK}}$ is automatically generated, regardless of the value of ACEK0. When an address other than that of the local address is received, $\overline{\text{ACK}}$ is not generated (NACK).

When an extension code is received, $\overline{\text{ACK}}$ is generated if ACEK0 is set to 1 in advance.

How $\overline{\text{ACK}}$ is generated when data is received differs as follows depending on the setting of the wait timing.

- When 8-clock wait state is selected (bit 3 (WTIM0) of IICC0 register = 0):
By setting ACEK0 to 1 before releasing the wait state, $\overline{\text{ACK}}$ is generated at the falling edge of the eighth clock of the SCL0 pin.
- When 9-clock wait state is selected (bit 3 (WTIM0) of IICC0 register = 1):
 $\overline{\text{ACK}}$ is generated by setting ACEK0 to 1 in advance.

14.5.5 Stop condition

When the SCL0 pin is at high level, changing the SDA0 pin from low level to high level generates a stop condition.

A stop condition is a signal that the master device generates to the slave device when serial transfer has been completed. When the device is used as a slave, stop conditions can be detected.

Figure 14-17. Stop Condition

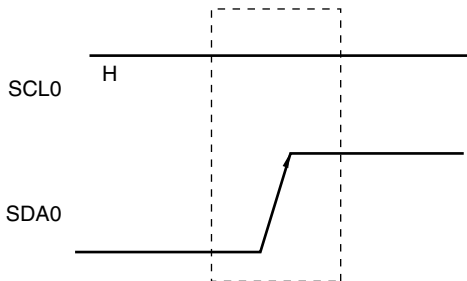

A stop condition is generated when bit 0 (SPT0) of IIC control register 0 (IICC0) is set to 1. When the stop condition is detected, bit 0 (SPD0) of IIC status register 0 (IICS0) is set to 1 and INTIIC0 is generated when bit 4 (SPIE0) of IICC0 is set to 1.

14.5.6 Wait

The wait is used to notify the communication partner that a device (master or slave) is preparing to transmit or receive data (i.e., is in a wait state).

Setting the SCL0 pin to low level notifies the communication partner of the wait state. When wait state has been canceled for both the master and slave devices, the next data transfer can begin.

Figure 14-18. Wait (1/2)

(1) When master device has a nine-clock wait and slave device has an eight-clock wait (master transmits, slave receives, and ACKE0 = 1)

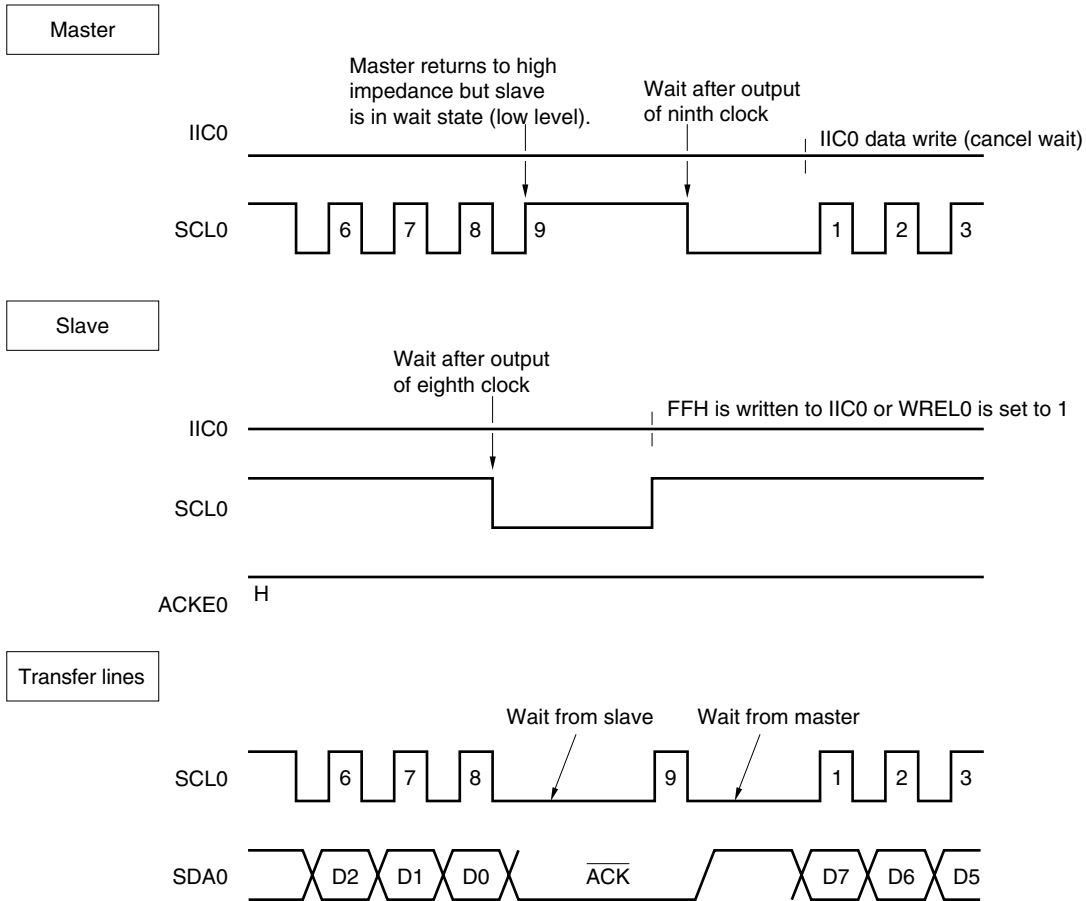
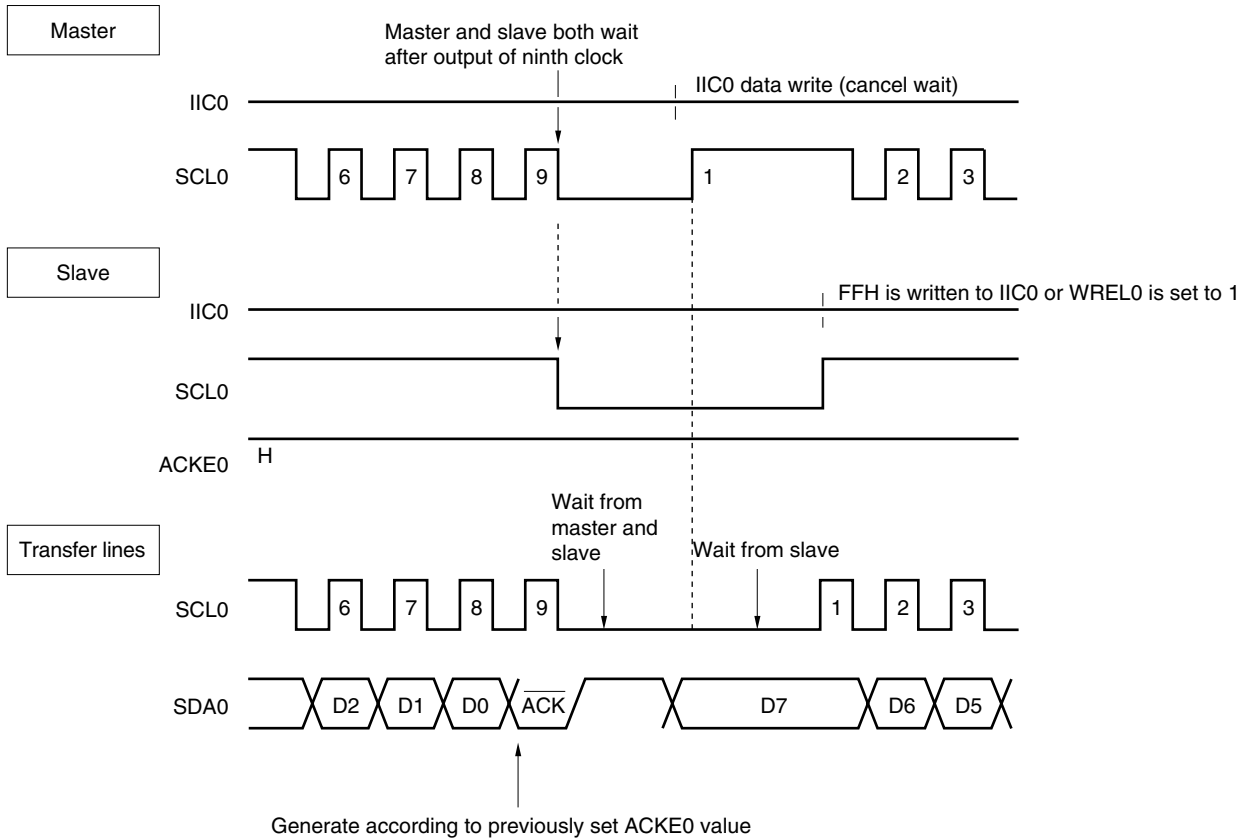

Figure 14-18. Wait (2/2)

(2) When master and slave devices both have a nine-clock wait (master transmits, slave receives, and ACKE0 = 1)



Remark ACKE0: Bit 2 of IIC control register 0 (IICC0)
 WRELO: Bit 5 of IIC control register 0 (IICC0)

A wait may be automatically generated depending on the setting of bit 3 (WTIM0) of IIC control register 0 (IICC0). Normally, the receiving side cancels the wait state when bit 5 (WRELO) of IICC0 is set to 1 or when FFH is written to IIC shift register 0 (IIC0), and the transmitting side cancels the wait state when data is written to IIC0.

The master device can also cancel the wait state via either of the following methods.

- By setting bit 1 (STT0) of IICC0 to 1
- By setting bit 0 (SPT0) of IICC0 to 1

14.5.7 Canceling wait

The I²C usually cancels a wait state by the following processing.

- Writing data to IIC shift register 0 (IIC0)
- Setting bit 5 (WREL0) of IIC control register 0 (IICC0) (canceling wait)
- Setting bit 1 (STT0) of IIC0 register (generating start condition)^{Note}
- Setting bit 0 (SPT0) of IIC0 register (generating stop condition)^{Note}

Note Master only

When the above wait canceling processing is executed, the I²C cancels the wait state and communication is resumed.

To cancel a wait state and transmit data (including addresses), write the data to IIC0.

To receive data after canceling a wait state, or to complete data transmission, set bit 5 (WREL0) of the IIC0 control register 0 (IICC0) to 1.

To generate a restart condition after canceling a wait state, set bit 1 (STT0) of IICC0 to 1.

To generate a stop condition after canceling a wait state, set bit 0 (SPT0) of IICC0 to 1.

Execute the canceling processing only once for one wait state.

If, for example, data is written to IIC0 after canceling a wait state by setting WREL0 to 1, an incorrect value may be output to SDA0 because the timing for changing the SDA0 line conflicts with the timing for writing IIC0.

In addition to the above, communication is stopped if IICE0 is cleared to 0 when communication has been aborted, so that the wait state can be canceled.

If the I²C bus has deadlocked due to noise, processing is saved from communication by setting bit 6 (LREL0) of IICC0, so that the wait state can be canceled.

14.5.8 Interrupt request (INTIIC0) generation timing and wait control

The setting of bit 3 (WTIM0) of IIC control register 0 (IICC0) determines the timing by which INTIIC0 is generated and the corresponding wait control, as shown in Table 14-3.

Table 14-3. INTIIC0 Generation Timing and Wait Control

WTIM0	During Slave Device Operation			During Master Device Operation		
	Address	Data Reception	Data Transmission	Address	Data Reception	Data Transmission
0	9 ^{Notes 1, 2}	8 ^{Note 2}	8 ^{Note 2}	9	8	8
1	9 ^{Notes 1, 2}	9 ^{Note 2}	9 ^{Note 2}	9	9	9

Notes 1. The slave device's INTIIC0 signal and wait period occurs at the falling edge of the ninth clock only when there is a match with the address set to slave address register 0 (SVA0).

At this point, \overline{ACK} is generated regardless of the value set to IICC0's bit 2 (ACKE0). For a slave device that has received an extension code, INTIIC0 occurs at the falling edge of the eighth clock.

However, if the address does not match after restart, INTIIC0 is generated at the falling edge of the 9th clock, but wait does not occur.

2. If the received address does not match the contents of slave address register 0 (SVA0) and extension code is not received, neither INTIIC0 nor a wait occurs.

Remark The numbers in the table indicate the number of the serial clock's clock signals. Interrupt requests and wait control are both synchronized with the falling edge of these clock signals.

(1) During address transmission/reception

- Slave device operation: Interrupt and wait timing are determined depending on the conditions described in Notes 1 and 2 above, regardless of the WTIM0 bit.
- Master device operation: Interrupt and wait timing occur at the falling edge of the ninth clock regardless of the WTIM0 bit.

(2) During data reception

- Master/slave device operation: Interrupt and wait timing are determined according to the WTIM0 bit.

(3) During data transmission

- Master/slave device operation: Interrupt and wait timing are determined according to the WTIM0 bit.

(4) Wait cancellation method

The four wait cancellation methods are as follows.

- Writing data to IIC shift register 0 (IIC0)
- Setting bit 5 (WRELO) of IIC control register 0 (IICC0) (canceling wait)
- Setting bit 1 (STT0) of IIC0 register (generating start condition)^{Note}
- Setting bit 0 (SPT0) of IIC0 register (generating stop condition)^{Note}

Note Master only.

When an 8-clock wait has been selected (WTIM0 = 0), the presence/absence of $\overline{\text{ACK}}$ generation must be determined prior to wait cancellation.

(5) Stop condition detection

INTIIC0 is generated when a stop condition is detected (only when SPIE0 = 1).

14.5.9 Address match detection method

In I²C bus mode, the master device can select a particular slave device by transmitting the corresponding slave address.

Address match can be detected automatically by hardware. An interrupt request (INTIIC0) occurs when a local address has been set to slave address register 0 (SVA0) and when the address set to SVA0 matches the slave address sent by the master device, or when an extension code has been received.

14.5.10 Error detection

In I²C bus mode, the status of the serial data bus (SDA0) during data transmission is captured by IIC shift register 0 (IIC0) of the transmitting device, so the IIC0 data prior to transmission can be compared with the transmitted IIC0 data to enable detection of transmission errors. A transmission error is judged as having occurred when the compared data values do not match.

14.5.11 Extension code

- (1) When the higher 4 bits of the receive address are either “0000” or “1111”, the extension code reception flag (EXC0) is set to 1 for extension code reception and an interrupt request (INTIIC0) is issued at the falling edge of the eighth clock. The local address stored in slave address register 0 (SVA0) is not affected.
- (2) If “11110xx0” is set to SVA0 by a 10-bit address transfer and “11110xx0” is transferred from the master device, the results are as follows. Note that INTIIC0 occurs at the falling edge of the eighth clock.
- Higher four bits of data match: EXC0 = 1
 - Seven bits of data match: COI0 = 1

Remark EXC0: Bit 5 of IIC status register 0 (IICS0)
COI0: Bit 4 of IIC status register 0 (IICS0)

- (3) Since the processing after the interrupt request occurs differs according to the data that follows the extension code, such processing is performed by software.
- If the extension code is received while a slave device is operating, then the slave device is participating in communication even if its address does not match.
- For example, after the extension code is received, if you do not wish to operate the target device as a slave device, set bit 6 (LREL0) of the IIC control register 0 (IICC0) to 1 to set the standby mode for the next communication operation.

Table 14-4. Extension Code Bit Definitions

Slave Address	R/W Bit	Description
0 0 0 0 0 0 0	0	General call address
0 0 0 0 0 0 0	1	Start byte
0 0 0 0 0 0 1	×	C-BUS address
0 0 0 0 0 1 0	×	Address that is reserved for different bus format
1 1 1 1 0 X X	×	10-bit slave address specification

14.5.12 Arbitration

When several master devices simultaneously generate a start condition (when STT0 is set to 1 before STD0 is set to 1), communication among the master devices is performed as the number of clocks are adjusted until the data differs. This kind of operation is called arbitration.

When one of the master devices loses in arbitration, an arbitration loss flag (ALD0) in IIC status register 0 (IICS0) is set (1) via the timing by which the arbitration loss occurred, and the SCL0 and SDA0 lines are both set to high impedance, which releases the bus.

The arbitration loss is detected based on the timing of the next interrupt request (the eighth or ninth clock, when a stop condition is detected, etc.) and the ALD0 = 1 setting that has been made by software.

For details of interrupt request timing, see **14.5.17 Timing of I²C interrupt request (INTIIC0) occurrence.**

Remark STD0: Bit 1 of IIC status register 0 (IICS0)
STT0: Bit 1 of IIC control register 0 (IICC0)

Figure 14-19. Arbitration Timing Example

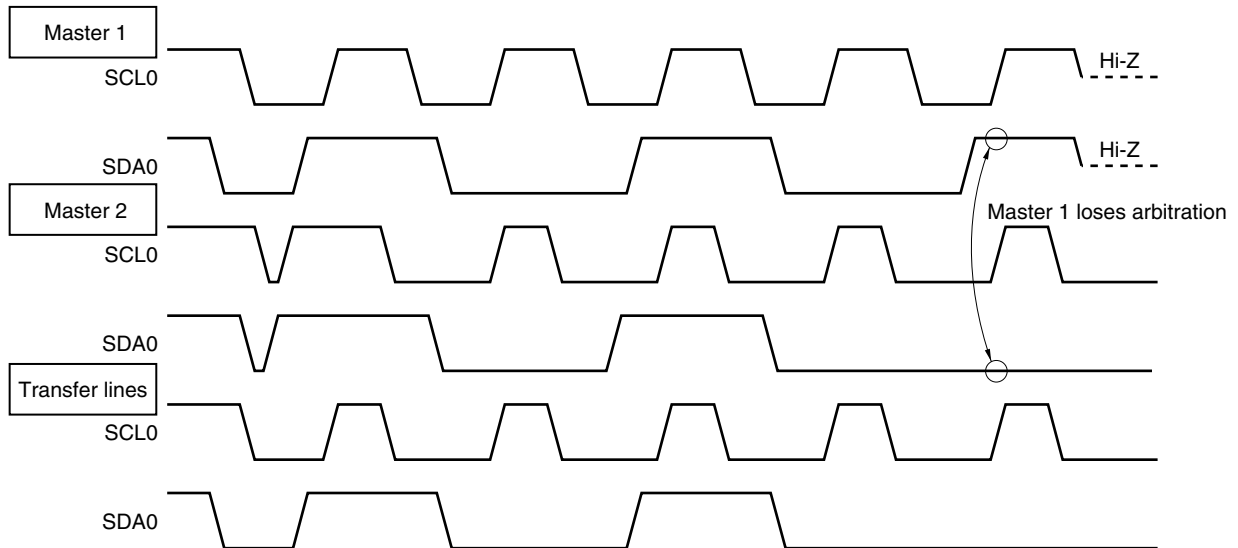

Table 14-5. Status During Arbitration and Interrupt Request Generation Timing

Status During Arbitration	Interrupt Request Generation Timing
During address transmission	At falling edge of eighth or ninth clock following byte transfer ^{Note 1}
Read/write data after address transmission	
During extension code transmission	
Read/write data after extension code transmission	
During data transmission	
During $\overline{\text{ACK}}$ transfer period after data transmission	
When restart condition is detected during data transfer	
When stop condition is detected during data transfer	When stop condition is generated (when SPIE0 = 1) ^{Note 2}
When data is at low level while attempting to generate a restart condition	At falling edge of eighth or ninth clock following byte transfer ^{Note 1}
When stop condition is detected while attempting to generate a restart condition	When stop condition is generated (when SPIE0 = 1) ^{Note 2}
When data is at low level while attempting to generate a stop condition	At falling edge of eighth or ninth clock following byte transfer ^{Note 1}
When SCL0 is at low level while attempting to generate a restart condition	

Notes 1. When WTIM0 (bit 3 of IIC control register 0 (IICC0)) = 1, an interrupt request occurs at the falling edge of the ninth clock. When WTIM0 = 0 and the extension code's slave address is received, an interrupt request occurs at the falling edge of the eighth clock.

2. When there is a chance that arbitration will occur, set SPIE0 = 1 for master device operation.

Remark SPIE0: Bit 4 of IIC control register 0 (IICC0)

14.5.13 Wakeup function

The I²C bus slave function is a function that generates an interrupt request signal (INTIIC0) when a local address and extension code have been received.

This function makes processing more efficient by preventing unnecessary INTIIC0 signal from occurring when addresses do not match.

When a start condition is detected, wakeup standby mode is set. This wakeup standby mode is in effect while addresses are transmitted due to the possibility that an arbitration loss may change the master device (which has generated a start condition) to a slave device.

However, when a stop condition is detected, bit 4 (SPIE0) of IIC control register 0 (IICC0) is set regardless of the wakeup function, and this determines whether interrupt requests are enabled or disabled.

14.5.14 Communication reservation

(1) When communication reservation function is enabled (bit 0 (IICRSV) of IIC flag register 0 (IICF0) = 0)

To start master device communications when not currently using a bus, a communication reservation can be made to enable transmission of a start condition when the bus is released. There are two modes under which the bus is not used.

- When arbitration results in neither master nor slave operation
- When an extension code is received and slave operation is disabled (\overline{ACK} is not returned and the bus was released when bit 6 (LREL0) of IIC control register 0 (IICC0) was set to 1).

If bit 1 (STT0) of IICC0 is set to 1 while the bus is not used (after a stop condition is detected), a start condition is automatically generated and wait state is set.

If an address is written to IIC shift register 0 (IIC0) after bit 4 (SPIE0) of IICC0 was set to 1, and it was detected by generation of an interrupt request signal (INTIIC0) that the bus was released (detection of the stop condition), then the device automatically starts communication as the master. Data written to IIC0 before the stop condition is detected is invalid.

When STT0 has been set to 1, the operation mode (as start condition or as communication reservation) is determined according to the bus status.

- If the bus has been releaseda start condition is generated
- If the bus has not been released (standby mode)communication reservation

Check whether the communication reservation operates or not by using MSTS0 (bit 7 of IIC status register 0 (IICS0)) after STT0 is set to 1 and the wait time elapses.

The wait periods, which should be set via software, are listed in Table 14-6.

Table 14-6. Wait Periods

CLX0	SMC0	CL01	CL00	Wait Period
0	0	0	0	46 clocks
0	0	0	1	86 clocks
0	0	1	0	172 clocks
0	1	0	0	30 clocks
0	1	0	1	
0	1	1	0	60 clocks
1	1	0	0	18 clocks
1	1	0	1	
1	1	1	0	36 clocks

Figure 14-20 shows the communication reservation timing.

Figure 14-20. Communication Reservation Timing

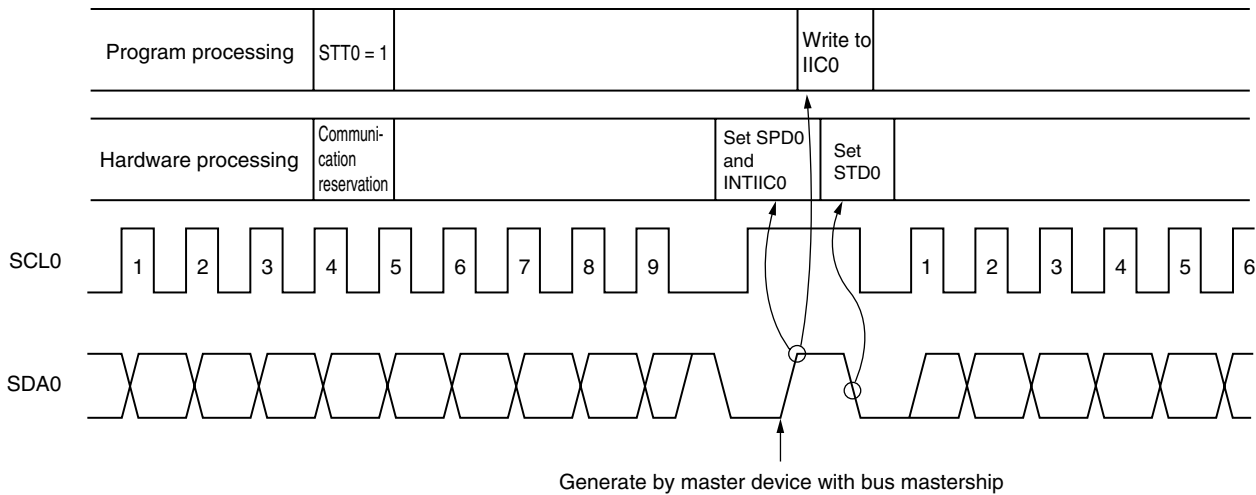

Remark IIC0: IIC shift register 0
 STT0: Bit 1 of IIC control register 0 (IICC0)
 STD0: Bit 1 of IIC status register 0 (IICS0)
 SPD0: Bit 0 of IIC status register 0 (IICS0)

Communication reservations are accepted via the following timing. After bit 1 (STD0) of IIC status register 0 (IICS0) is set to 1, a communication reservation can be made by setting bit 1 (STT0) of IIC control register 0 (IICC0) to 1 before a stop condition is detected.

Figure 14-21. Timing for Accepting Communication Reservations

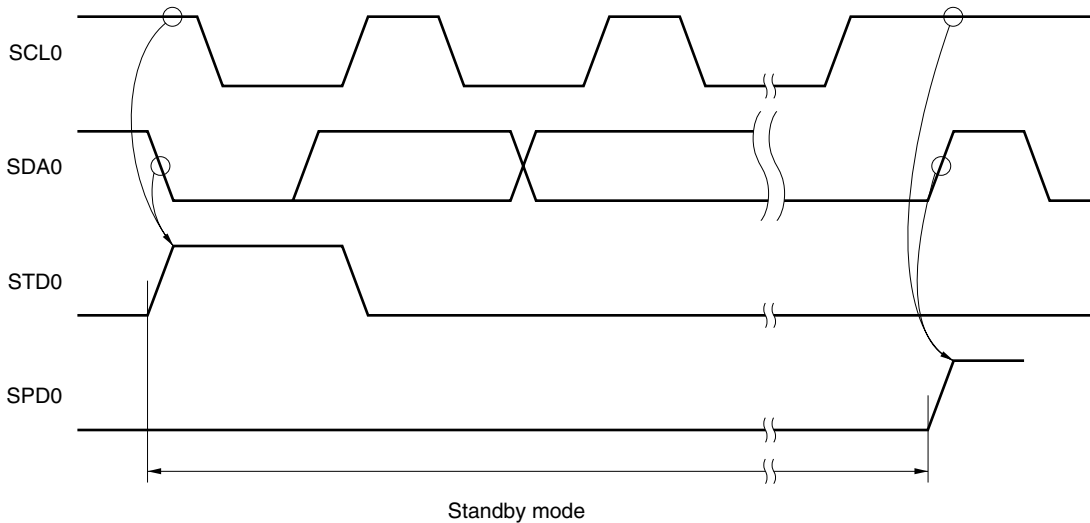
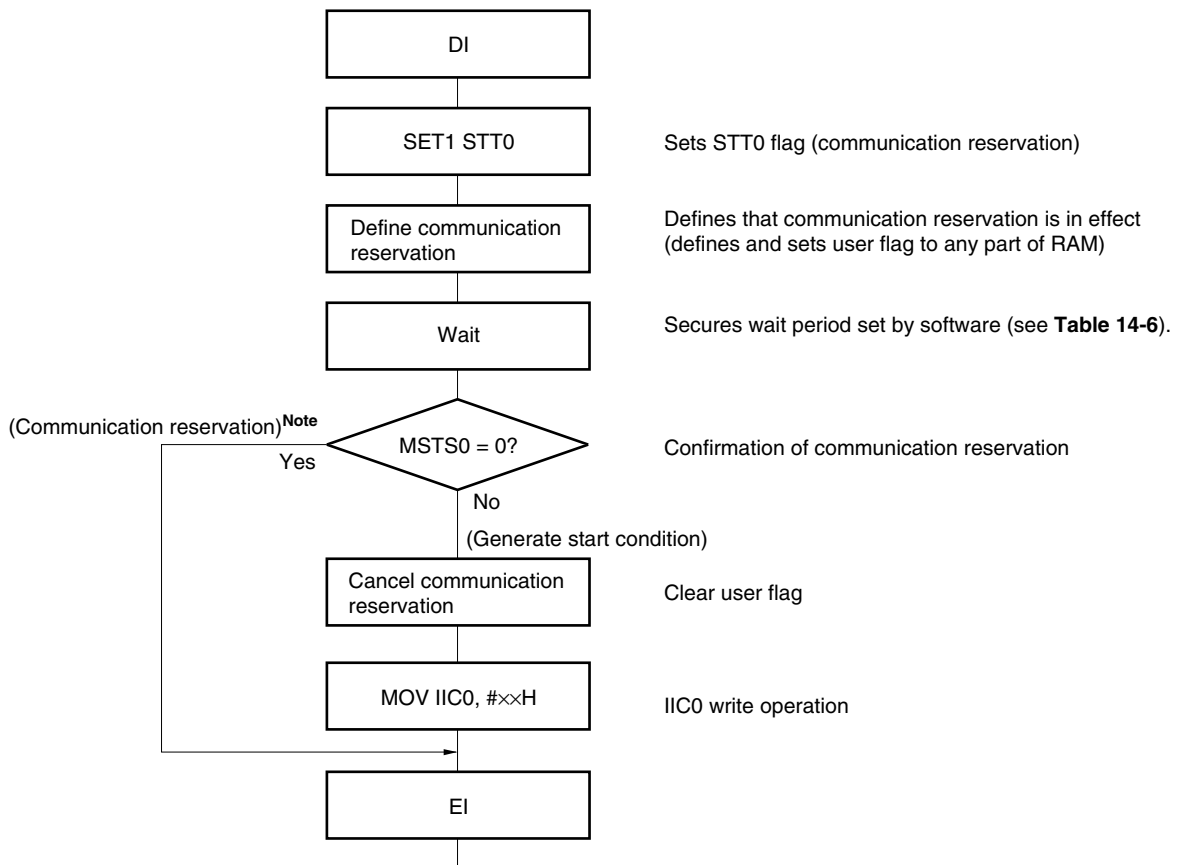

Figure 14-22 shows the communication reservation protocol.

Figure 14-22. Communication Reservation Protocol



Note The communication reservation operation executes a write to IIC shift register 0 (IIC0) when a stop condition interrupt request occurs.

Remark STT0: Bit 1 of IIC control register 0 (IICC0)
 MSTS0: Bit 7 of IIC status register 0 (IICS0)
 IIC0: IIC shift register 0

(2) When communication reservation function is disabled (bit 0 (IICRSV) of IIC flag register 0 (IICF0) = 1)

When bit 1 (STT0) of IIC control register 0 (IICC0) is set to 1 when the bus is not used in a communication during bus communication, this request is rejected and a start condition is not generated. The following two statuses are included in the status where bus is not used.

- When arbitration results in neither master nor slave operation
- When an extension code is received and slave operation is disabled (\overline{ACK} is not returned and the bus was released when bit 6 (LREL0) of IICC0 was set to 1)

To confirm whether the start condition was generated or request was rejected, check STCF (bit 7 of IICF0). The time shown in Table 14-7 is required until STCF is set to 1 after setting STT0 = 1. Therefore, secure the time by software.

Table 14-7. Wait Periods

CL01	CL00	Wait Period
0	0	6 clocks
0	1	6 clocks
1	0	12 clocks

14.5.15 Other cautions

(1) When STCEN (bit 1 of IIC flag register 0 (IICF0)) = 0

Immediately after I²C operation is enabled (IICE0 = 1), the bus communication status (IICBSY (bit 6 of IICF0) = 1) is recognized regardless of the actual bus status. When changing from a mode in which no stop condition has been detected to a master device communication mode, first generate a stop condition to release the bus, then perform master device communication.

When using multiple masters, it is not possible to perform master device communication when the bus has not been released (when a stop condition has not been detected).

Use the following sequence for generating a stop condition.

- <1> Set IIC clock selection register 0 (IICCL0).
- <2> Set bit 7 (IICE0) of IIC control register 0 (IICC0) to 1.
- <3> Set bit 0 (SPT0) of IICC0 to 1.

(2) When STCEN = 1

Immediately after I²C operation is enabled (IICE0 = 1), the bus released status (IICBSY = 0) is recognized regardless of the actual bus status. To generate the first start condition (STT0 (bit 1 of IIC control register 0 (IICC0)) = 1), it is necessary to confirm that the bus has been released, so as to not disturb other communications.

(3) If other I²C communications are already in progress

If I²C operation is enabled and the device participates in communication already in progress when the SDA0 pin is low and the SCL0 pin is high, the macro of I²C recognizes that the SDA0 pin has gone low (detects a start condition). If the value on the bus at this time can be recognized as an extension code, \overline{ACK} is returned, but this interferes with other I²C communications. To avoid this, start I²C in the following sequence.

- <1> Clear bit 4 (SPIE0) of IICC0 to 0 to disable generation of an interrupt request signal (INTIIC0) when the stop condition is detected.
- <2> Set bit 7 (IICE0) of IICC0 to 1 to enable the operation of I²C.
- <3> Wait for detection of the start condition.
- <4> Set bit 6 (LREL0) of IICC0 to 1 before \overline{ACK} is returned (4 to 80 clocks after setting IICE0 to 1), to forcibly disable detection.

(4) Determine the transfer clock frequency by using SMC0, CL01, CL00 (bits 3, 1, and 0 of IICL0), and CLX0 (bit 0 of IICX0) before enabling the operation (IICE0 = 1). To change the transfer clock frequency, clear IICE0 to 0 once.

- (5) Setting STT0 and SPT0 (bits 1 and 0 of IICC0) again after they are set and before they are cleared to 0 is prohibited.
- (6) When transmission is reserved, set SPIE0 (bit 4 of IICL0) to 1 so that an interrupt request is generated when the stop condition is detected. Transfer is started when communication data is written to IIC0 after the interrupt request is generated. Unless the interrupt is generated when the stop condition is detected, the device stops in the wait state because the interrupt request is not generated when communication is started. However, it is not necessary to set SPIE0 to 1 when MST0 (bit 7 of IICS0) is detected by software.

14.5.16 Communication operations

The following shows three operation procedures with the flowchart.

<R>

(1) Master operation in single master system

The flowchart when using the 78K0/KB2 as the master in a single master system is shown below.

This flowchart is broadly divided into the initial settings and communication processing. Execute the initial settings at startup. If communication with the slave is required, prepare the communication and then execute communication processing.

<R>

(2) Master operation in multimaster system

In the I²C bus multimaster system, whether the bus is released or used cannot be judged by the I²C bus specifications when the bus takes part in a communication. Here, when data and clock are at a high level for a certain period (1 frame), the 78K0/KB2 takes part in a communication with bus released state.

This flowchart is broadly divided into the initial settings, communication waiting, and communication processing. The processing when the 78K0/KB2 loses in arbitration and is specified as the slave is omitted here, and only the processing as the master is shown. Execute the initial settings at startup to take part in a communication. Then, wait for the communication request as the master or wait for the specification as the slave. The actual communication is performed in the communication processing, and it supports the transmission/reception with the slave and the arbitration with other masters.

<R>

(3) Slave operation

An example of when the 78K0/KB2 is used as the I²C bus slave is shown below.

When used as the slave, operation is started by an interrupt. Execute the initial settings at startup, then wait for the INTIIC0 interrupt occurrence (communication waiting). When an INTIIC0 interrupt occurs, the communication status is judged and its result is passed as a flag over to the main processing.

By checking the flags, necessary communication processing is performed.

(1) Master operation in single-master system

Figure 14-23. Master Operation in Single-Master System

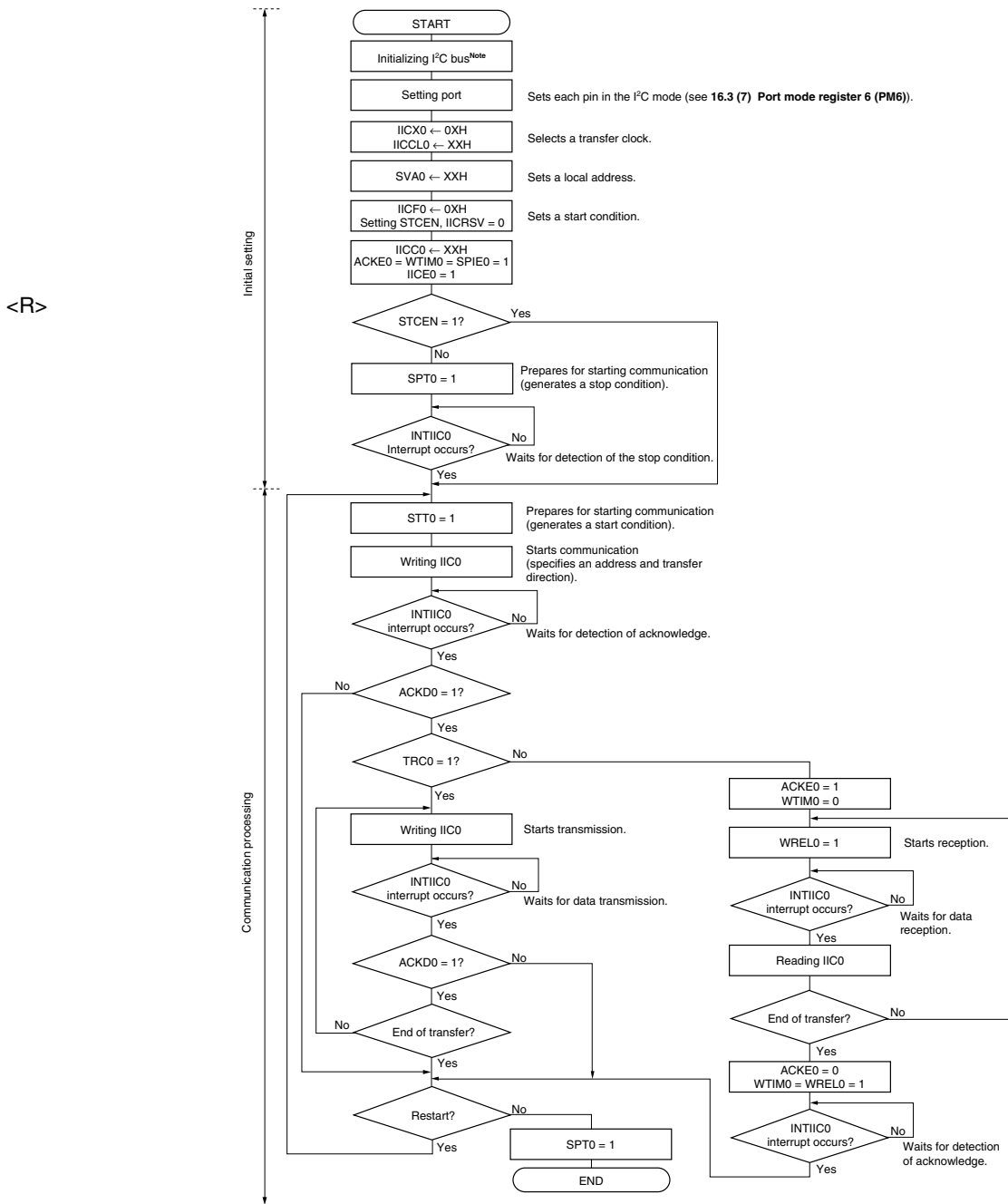

Note Release (SCL0 and SDA0 pins = high level) the I²C bus in conformance with the specifications of the product that is communicating. If EEPROM is outputting a low level to the SDA0 pin, for example, set the SCL0 pin in the output port mode, and output a clock pulse from the output port until the SDA0 pin is constantly at high level.

Remark Conform to the specifications of the product that is communicating, with respect to the transmission and reception formats.

(2) Master operation in multi-master system

Figure 14-24. Master Operation in Multi-Master System (1/3)

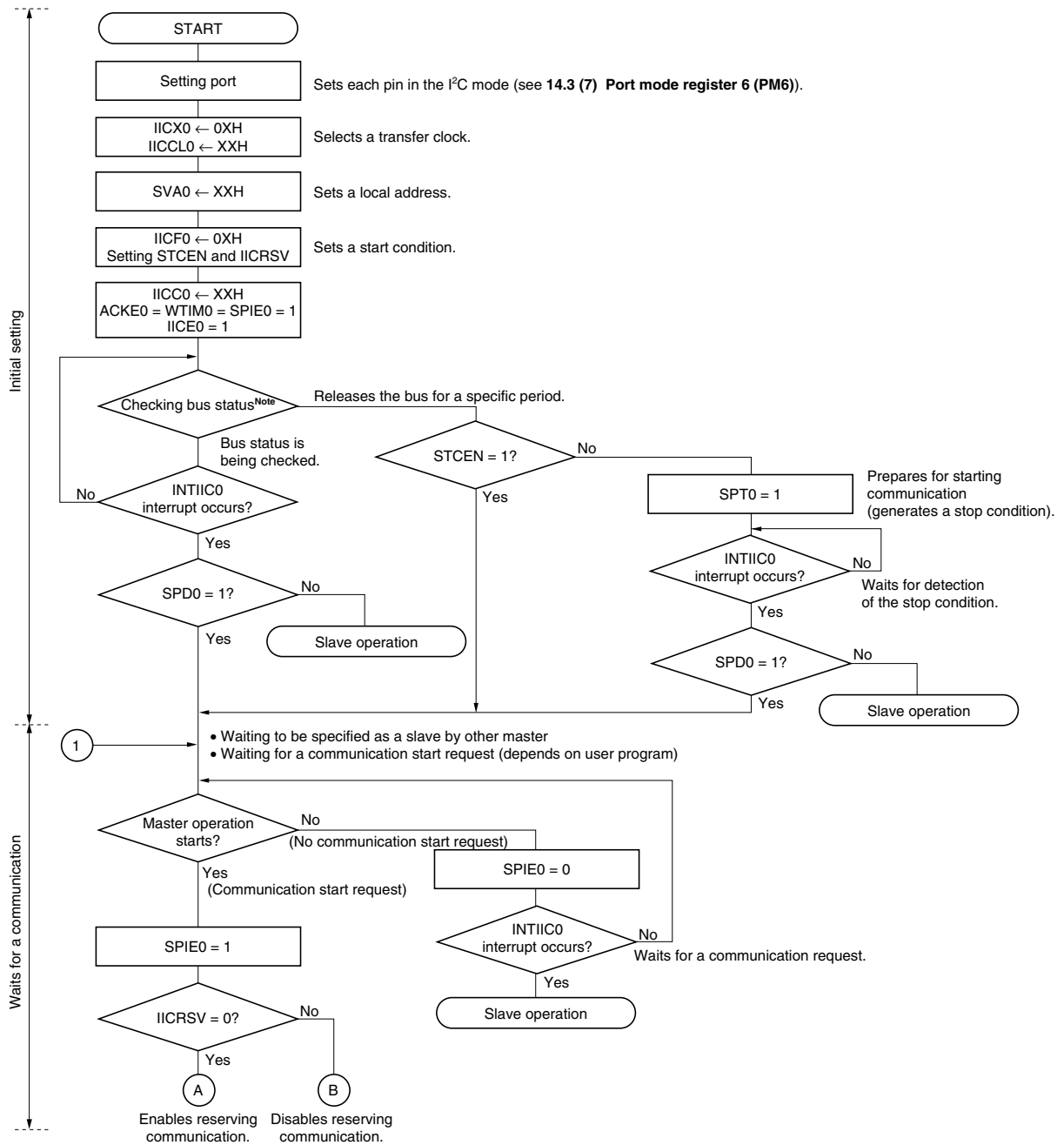

Note Confirm that the bus is released (CLD0 bit = 1, DAD0 bit = 1) for a specific period (for example, for a period of one frame). If the SDA0 pin is constantly at low level, decide whether to release the I²C bus (SCL0 and SDA0 pins = high level) in conformance with the specifications of the product that is communicating.

Figure 14-24. Master Operation in Multi-Master System (2/3)

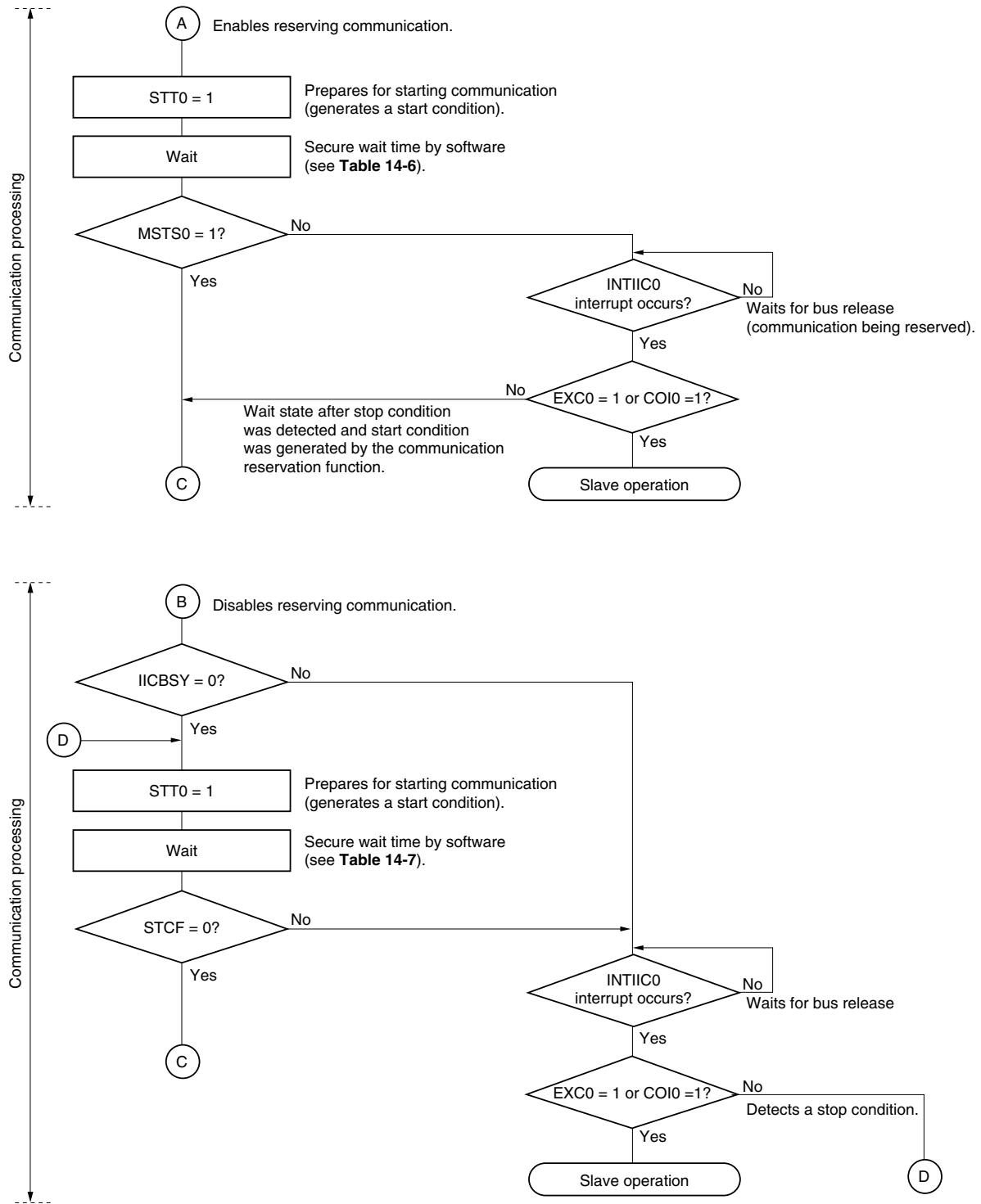
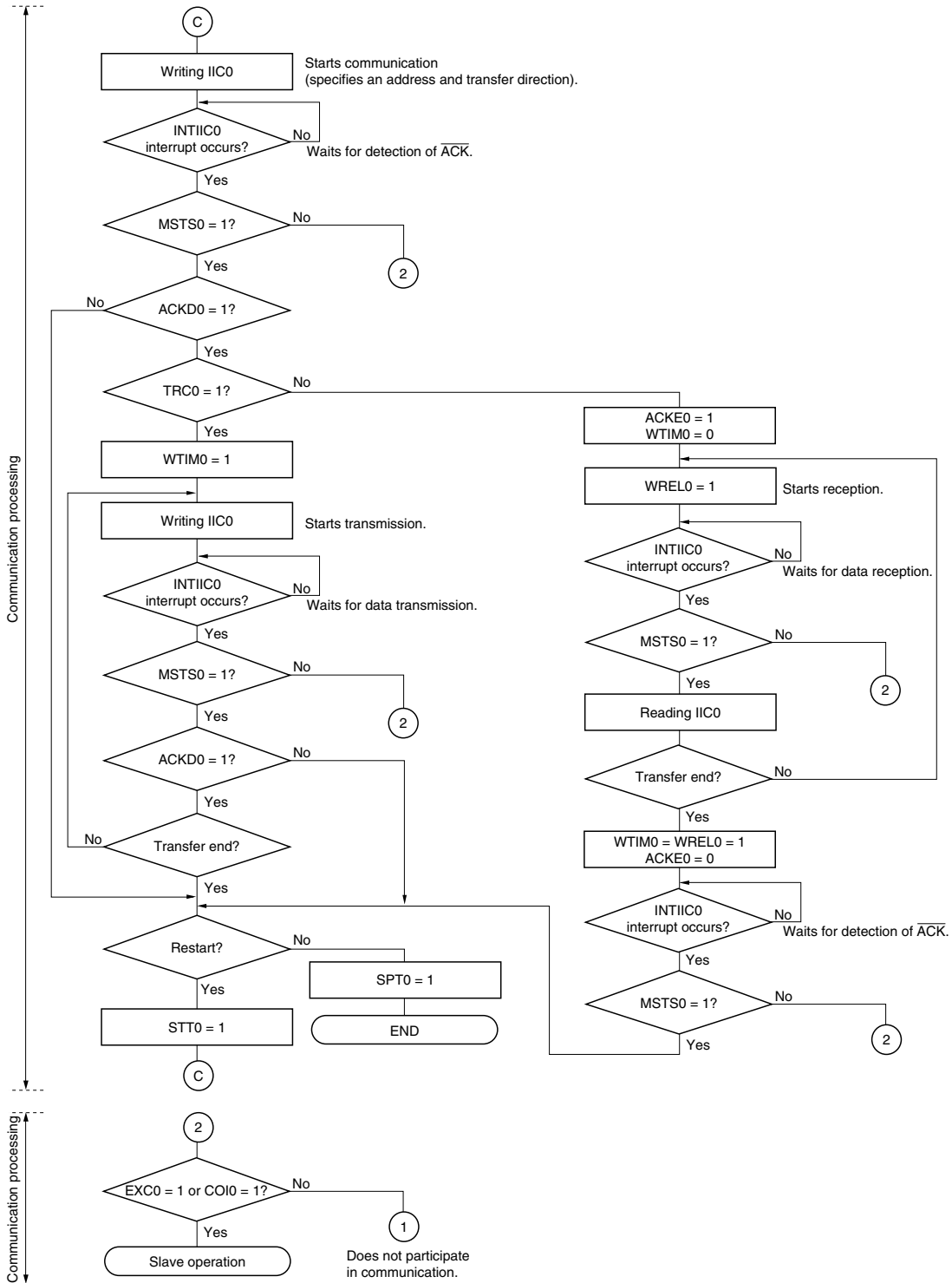

Figure 14-24. Master Operation in Multi-Master System (3/3)



- Remarks**
1. Conform to the specifications of the product that is communicating, with respect to the transmission and reception formats.
 2. To use the device as a master in a multi-master system, read the MSTS0 bit each time interrupt INTIIC0 has occurred to check the arbitration result.
 3. To use the device as a slave in a multi-master system, check the status by using the IICS0 and IICF0 registers each time interrupt INTIIC0 has occurred, and determine the processing to be performed next.

(3) Slave operation

The processing procedure of the slave operation is as follows.

Basically, the slave operation is event-driven. Therefore, processing by the INTIIC0 interrupt (processing that must substantially change the operation status such as detection of a stop condition during communication) is necessary.

In the following explanation, it is assumed that the extension code is not supported for data communication. It is also assumed that the INTIIC0 interrupt servicing only performs status transition processing, and that actual data communication is performed by the main processing.

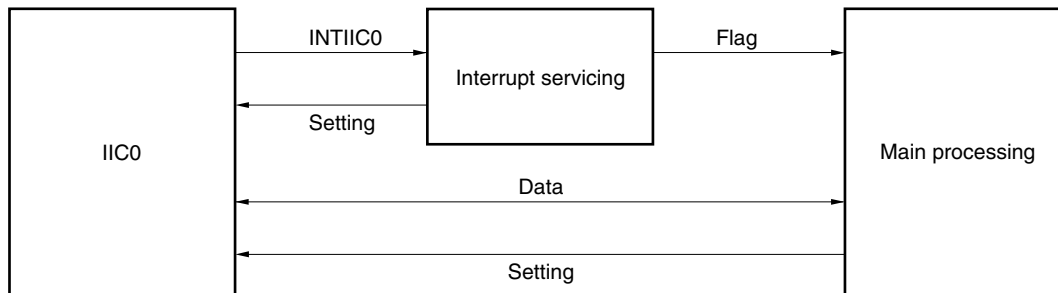

Therefore, data communication processing is performed by preparing the following three flags and passing them to the main processing instead of INTIIC0.

<1> Communication mode flag

This flag indicates the following two communication statuses.

- Clear mode: Status in which data communication is not performed
- Communication mode: Status in which data communication is performed (from valid address detection to stop condition detection, no detection of $\overline{\text{ACK}}$ from master, address mismatch)

<2> Ready flag

This flag indicates that data communication is enabled. Its function is the same as the INTIIC0 interrupt for ordinary data communication. This flag is set by interrupt servicing and cleared by the main processing. Clear this flag by interrupt servicing when communication is started. However, the ready flag is not set by interrupt servicing when the first data is transmitted. Therefore, the first data is transmitted without the flag being cleared (an address match is interpreted as a request for the next data).

<3> Communication direction flag

This flag indicates the direction of communication. Its value is the same as TRC0.

The main processing of the slave operation is explained next.

Start serial interface IIC0 and wait until communication is enabled. When communication is enabled, execute communication by using the communication mode flag and ready flag (processing of the stop condition and start condition is performed by an interrupt. Here, check the status by using the flags).

The transmission operation is repeated until the master no longer returns $\overline{\text{ACK}}$. If $\overline{\text{ACK}}$ is not returned from the master, communication is completed.

For reception, the necessary amount of data is received. When communication is completed, $\overline{\text{ACK}}$ is not returned as the next data. After that, the master generates a stop condition or restart condition. Exit from the communication status occurs in this way.

Figure 14-25. Slave Operation Flowchart (1)

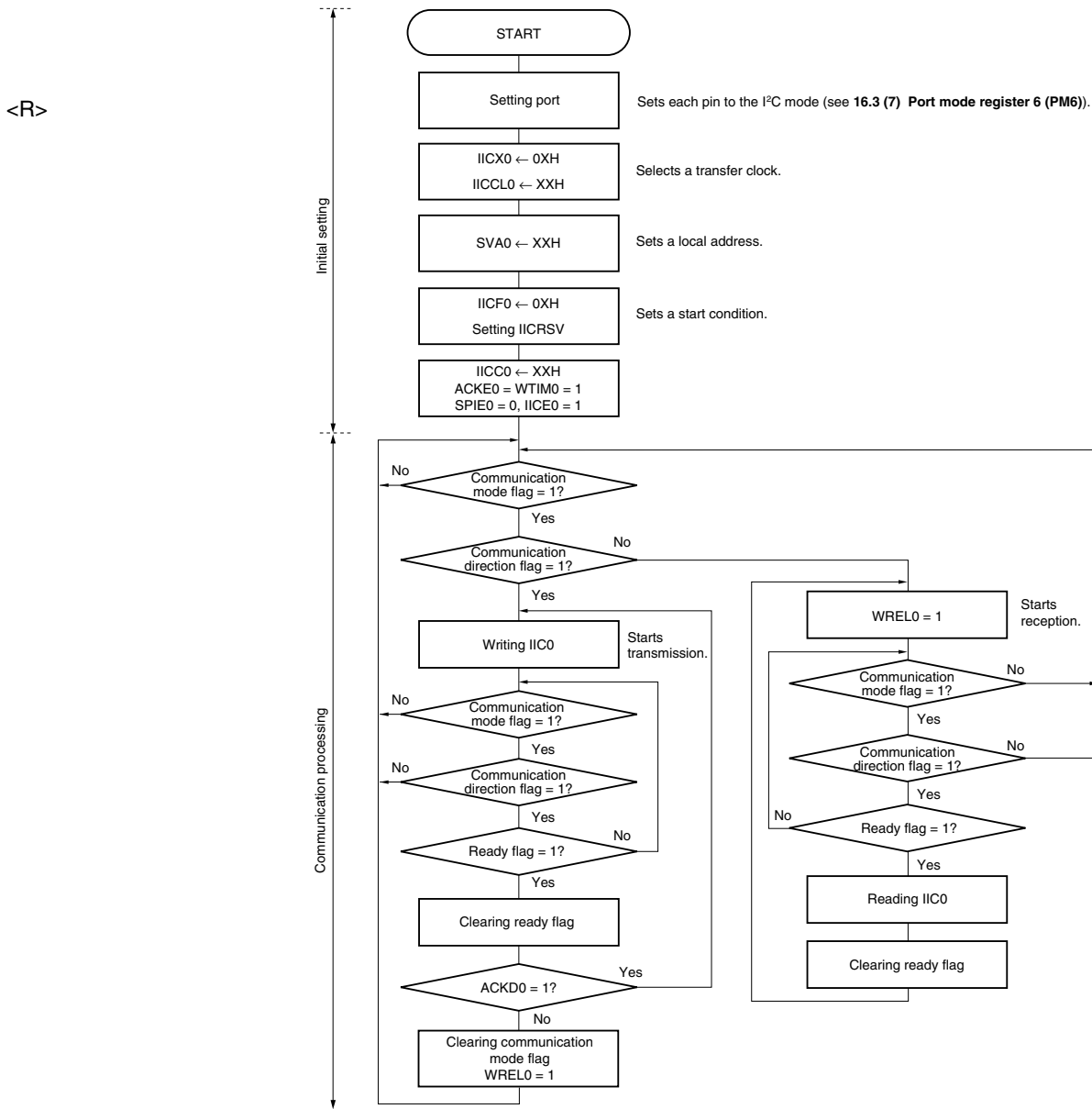

Remark Conform to the specifications of the product that is in communication, regarding the transmission and reception formats.

An example of the processing procedure of the slave with the INTIIC0 interrupt is explained below (processing is performed assuming that no extension code is used). The INTIIC0 interrupt checks the status, and the following operations are performed.

- <1> Communication is stopped if the stop condition is issued.
- <2> If the start condition is issued, the address is checked and communication is completed if the address does not match. If the address matches, the communication mode is set, wait is cancelled, and processing returns from the interrupt (the ready flag is cleared).
- <3> For data transmit/receive, only the ready flag is set. Processing returns from the interrupt with the I²C bus remaining in the wait state.

Remark <1> to <3> above correspond to <1> to <3> in **Figure 14-26 Slave Operation Flowchart (2)**.

Figure 14-26. Slave Operation Flowchart (2)

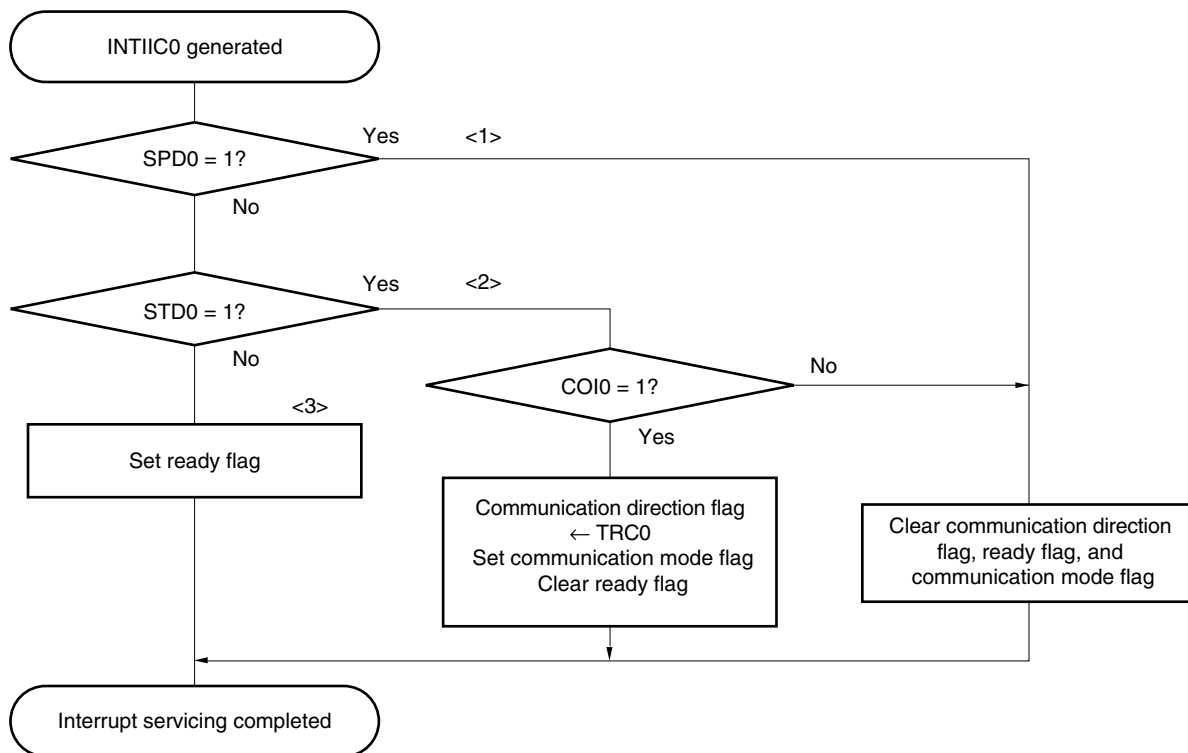

14.5.17 Timing of I²C interrupt request (INTIIC0) occurrence

The timing of transmitting or receiving data and generation of interrupt request signal INTIIC0, and the value of the IICS0 register when the INTIIC0 signal is generated are shown below.

Remark	ST:	Start condition
	AD6 to AD0:	Address
	R/W:	Transfer direction specification
	$\overline{\text{ACK}}$:	Acknowledge
	D7 to D0:	Data
	SP:	Stop condition

(1) Master device operation

(a) Start ~ Address ~ Data ~ Data ~ Stop (transmission/reception)

(i) When WTIM0 = 0

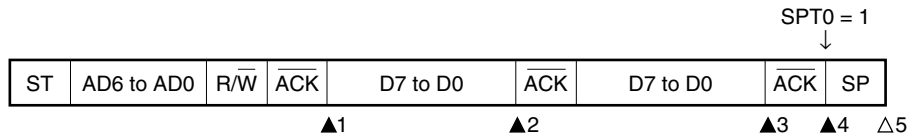

▲1: IIC0 = 1000x110B

▲2: IIC0 = 1000x000B

▲3: IIC0 = 1000x000B (Sets WTIM0 to 1)^{Note}

▲4: IIC0 = 1000x000B (Sets SPT0 to 1)^{Note}

△5: IIC0 = 00000001B

Note To generate a stop condition, set WTIM0 to 1 and change the timing for generating the INTIIC0 interrupt request signal.

Remark ▲: Always generated

△: Generated only when SPIE0 = 1

x: Don't care

(ii) When WTIM0 = 1

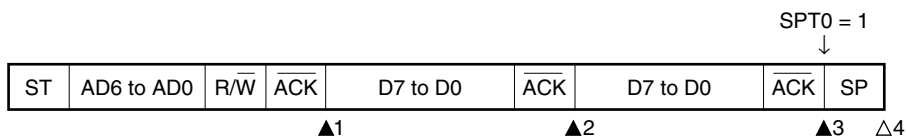

▲1: IIC0 = 1000x110B

▲2: IIC0 = 1000x100B

▲3: IIC0 = 1000x000B (Sets SPT0 to 1)

△4: IIC0 = 00000001B

Remark ▲: Always generated

△: Generated only when SPIE0 = 1

x: Don't care

(b) Start ~ Address ~ Data ~ Start ~ Address ~ Data ~ Stop (restart)

(i) When $WTIM0 = 0$

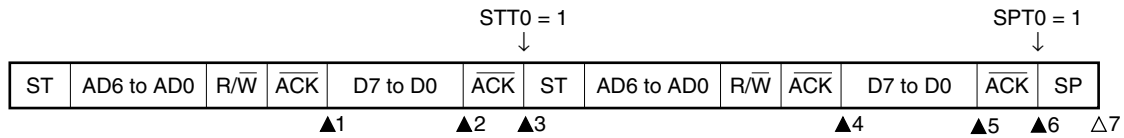

- ▲1: IICS0 = 1000x110B
- ▲2: IICS0 = 1000x000B (Sets $WTIM0$ to 1)^{Note 1}
- ▲3: IICS0 = 1000xx00B (Clears $WTIM0$ to 0^{Note 2}, sets $STT0$ to 1)
- ▲4: IICS0 = 1000x110B
- ▲5: IICS0 = 1000x000B (Sets $WTIM0$ to 1)^{Note 3}
- ▲6: IICS0 = 1000xx00B (Sets $SPT0$ to 1)
- Δ7: IICS0 = 00000001B

- Notes 1.** To generate a start condition, set $WTIM0$ to 1 and change the timing for generating the INTIIC0 interrupt request signal.
- 2.** Clear $WTIM0$ to 0 to restore the original setting.
- 3.** To generate a stop condition, set $WTIM0$ to 1 and change the timing for generating the INTIIC0 interrupt request signal.

Remark ▲: Always generated
 Δ: Generated only when $SPIE0 = 1$
 x: Don't care

(ii) When $WTIM0 = 1$

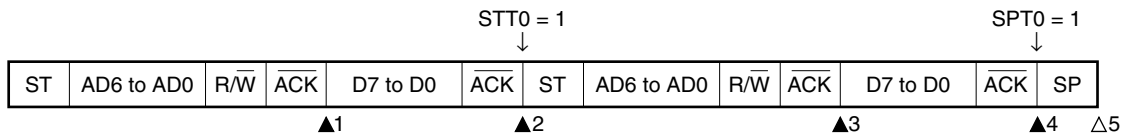

- ▲1: IICS0 = 1000x110B
- ▲2: IICS0 = 1000xx00B (Sets $STT0$ to 1)
- ▲3: IICS0 = 1000x110B
- ▲4: IICS0 = 1000xx00B (Sets $SPT0$ to 1)
- Δ5: IICS0 = 00000001B

Remark ▲: Always generated
 Δ: Generated only when $SPIE0 = 1$
 x: Don't care

(c) Start ~ Code ~ Data ~ Data ~ Stop (extension code transmission)

(i) When WTIM0 = 0

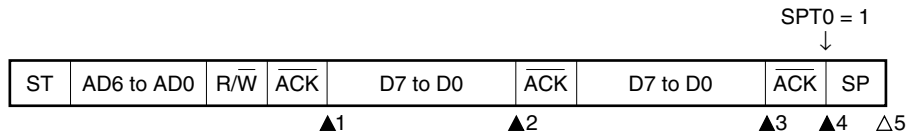

- ▲1: IICS0 = 1010x110B
- ▲2: IICS0 = 1010x000B
- ▲3: IICS0 = 1010x000B (Sets WTIM0 to 1)^{Note}
- ▲4: IICS0 = 1010xx00B (Sets SPT0 to 1)
- Δ5: IICS0 = 00000001B

Note To generate a stop condition, set WTIM0 to 1 and change the timing for generating the INTIIC0 interrupt request signal.

Remark ▲: Always generated
 Δ: Generated only when SPIE0 = 1
 x: Don't care

(ii) When WTIM0 = 1

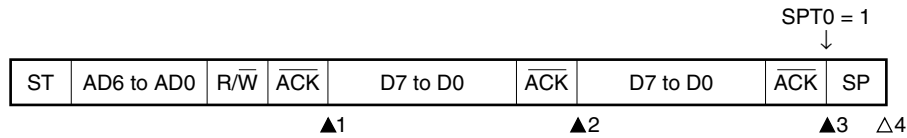

- ▲1: IICS0 = 1010x110B
- ▲2: IICS0 = 1010x100B
- ▲3: IICS0 = 1010xx00B (Sets SPT0 to 1)
- Δ4: IICS0 = 00001001B

Remark ▲: Always generated
 Δ: Generated only when SPIE0 = 1
 x: Don't care

(2) Slave device operation (slave address data reception)

(a) Start ~ Address ~ Data ~ Data ~ Stop

(i) When $WTIM0 = 0$

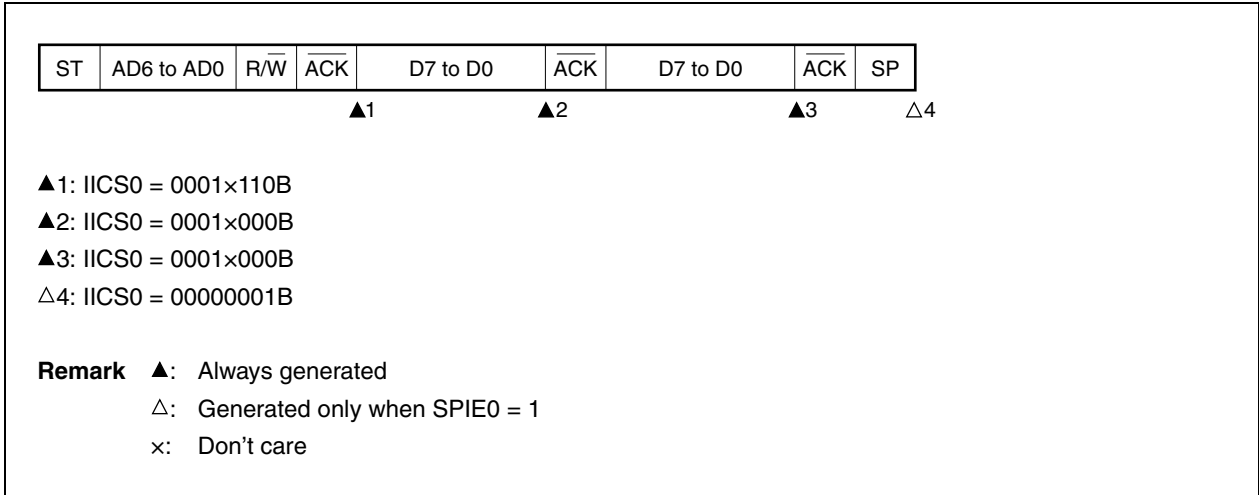

(ii) When $WTIM0 = 1$

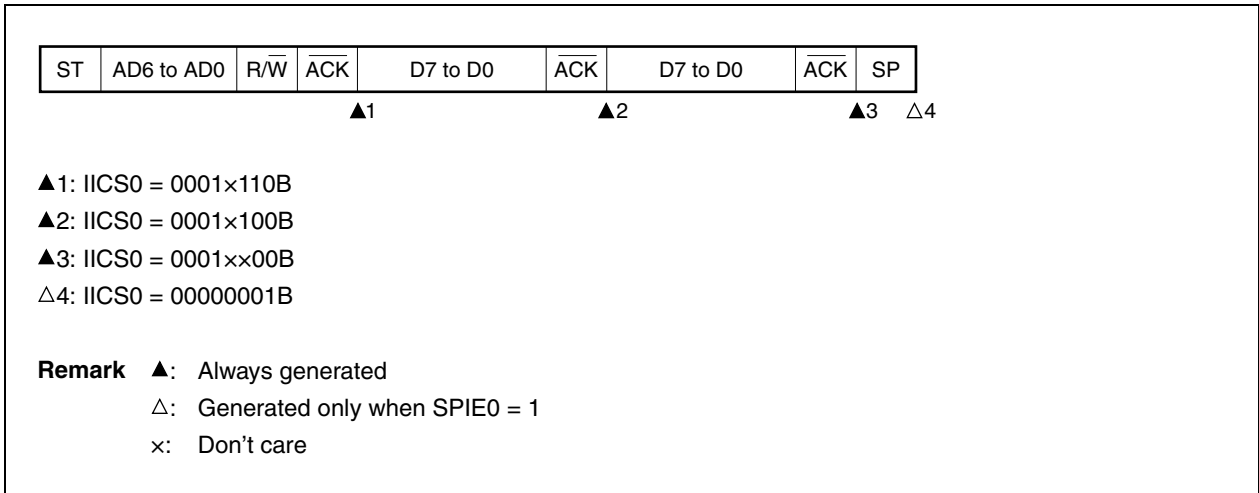

(b) Start ~ Address ~ Data ~ Start ~ Address ~ Data ~ Stop

(i) When WTIM0 = 0 (after restart, matches with SVA0)

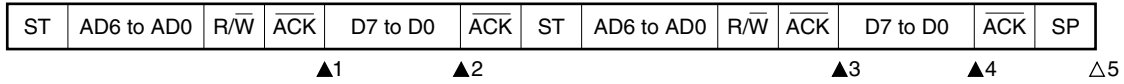

▲1: IICS0 = 0001x110B

▲2: IICS0 = 0001x000B

▲3: IICS0 = 0001x110B

▲4: IICS0 = 0001x000B

△5: IICS0 = 00000001B

Remark ▲: Always generated

△: Generated only when SPIE0 = 1

x: Don't care

(ii) When WTIM0 = 1 (after restart, matches with SVA0)

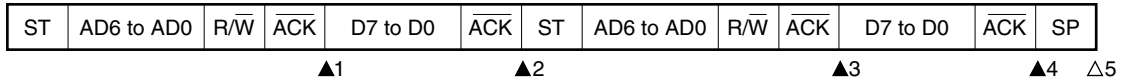

▲1: IICS0 = 0001x110B

▲2: IICS0 = 0001xx00B

▲3: IICS0 = 0001x110B

▲4: IICS0 = 0001xx00B

△5: IICS0 = 00000001B

Remark ▲: Always generated

△: Generated only when SPIE0 = 1

x: Don't care

(c) Start ~ Address ~ Data ~ Start ~ Code ~ Data ~ Stop

(i) When WTIM0 = 0 (after restart, does not match address (= extension code))

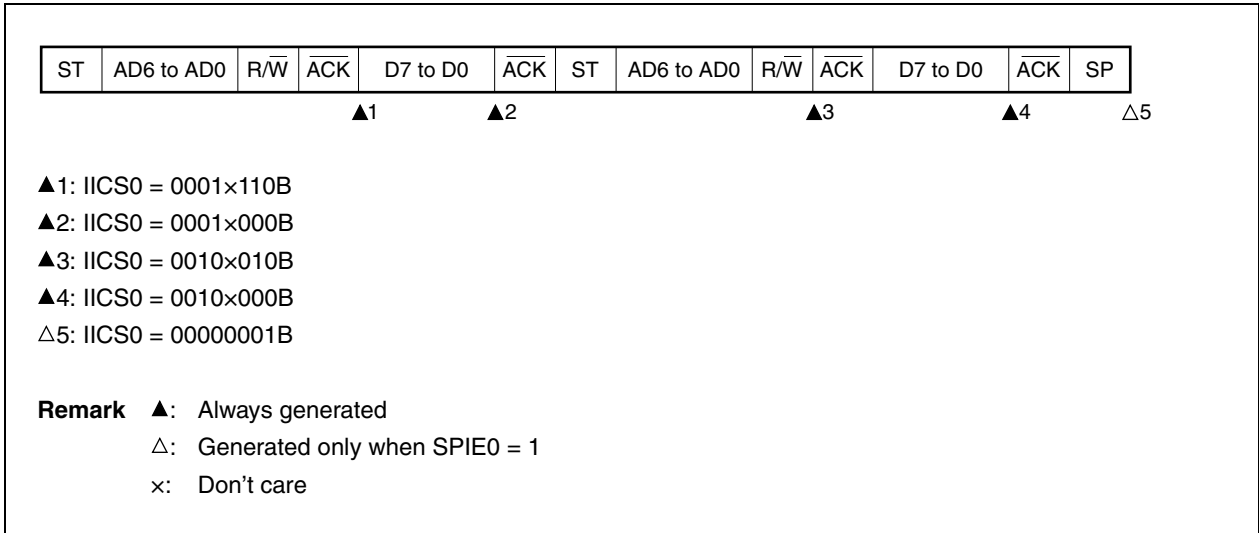

(ii) When WTIM0 = 1 (after restart, does not match address (= extension code))

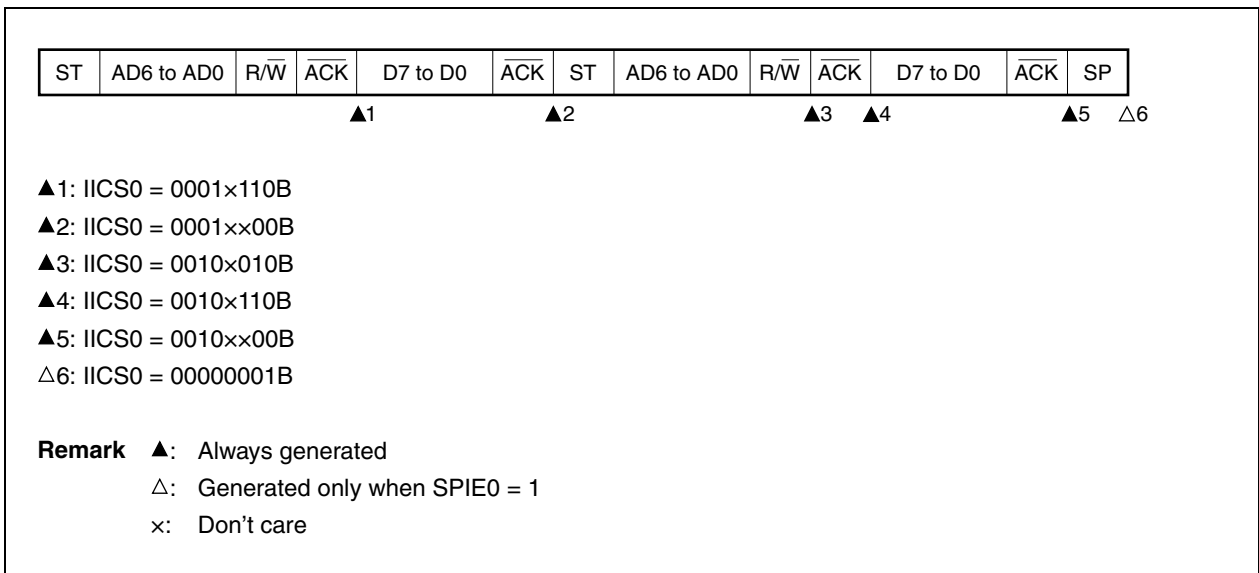

(d) Start ~ Address ~ Data ~ Start ~ Address ~ Data ~ Stop

(i) When WTIM0 = 0 (after restart, does not match address (= not extension code))

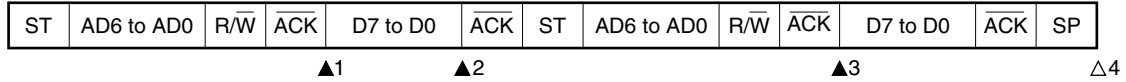

▲1: IICS0 = 0001x110B

▲2: IICS0 = 0001x000B

▲3: IICS0 = 00000110B

△4: IICS0 = 00000001B

Remark ▲: Always generated

△: Generated only when SPIE0 = 1

x: Don't care

(ii) When WTIM0 = 1 (after restart, does not match address (= not extension code))

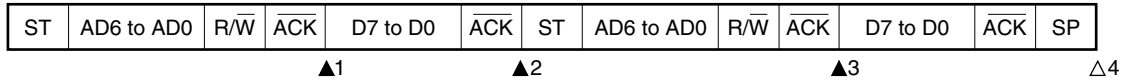

▲1: IICS0 = 0001x110B

▲2: IICS0 = 0001xx00B

▲3: IICS0 = 00000110B

△4: IICS0 = 00000001B

Remark ▲: Always generated

△: Generated only when SPIE0 = 1

x: Don't care

(3) Slave device operation (when receiving extension code)

The device is always participating in communication when it receives an extension code.

(a) Start ~ Code ~ Data ~ Data ~ Stop

(i) When WTIM0 = 0

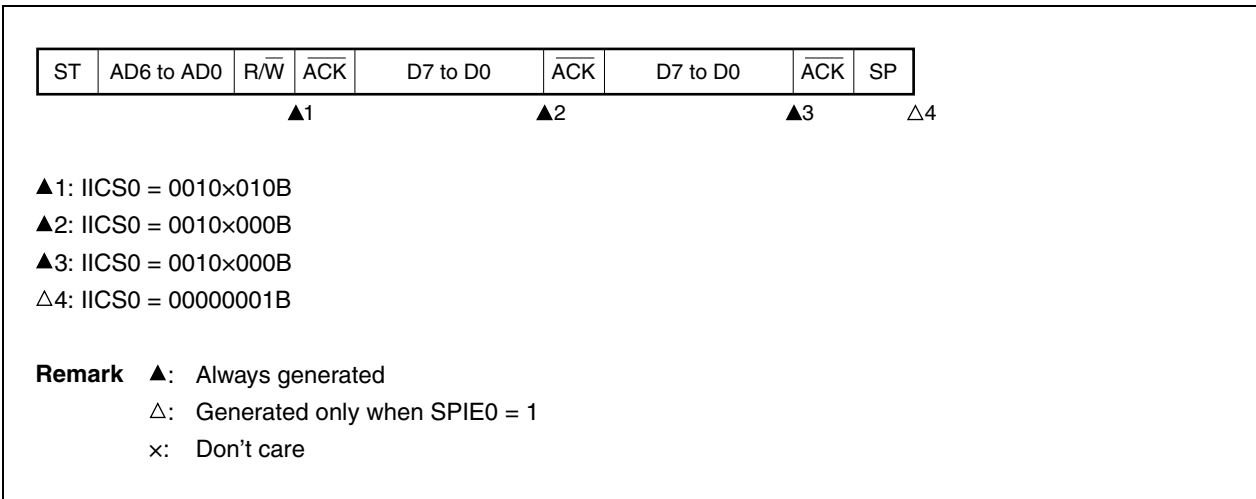

(ii) When WTIM0 = 1

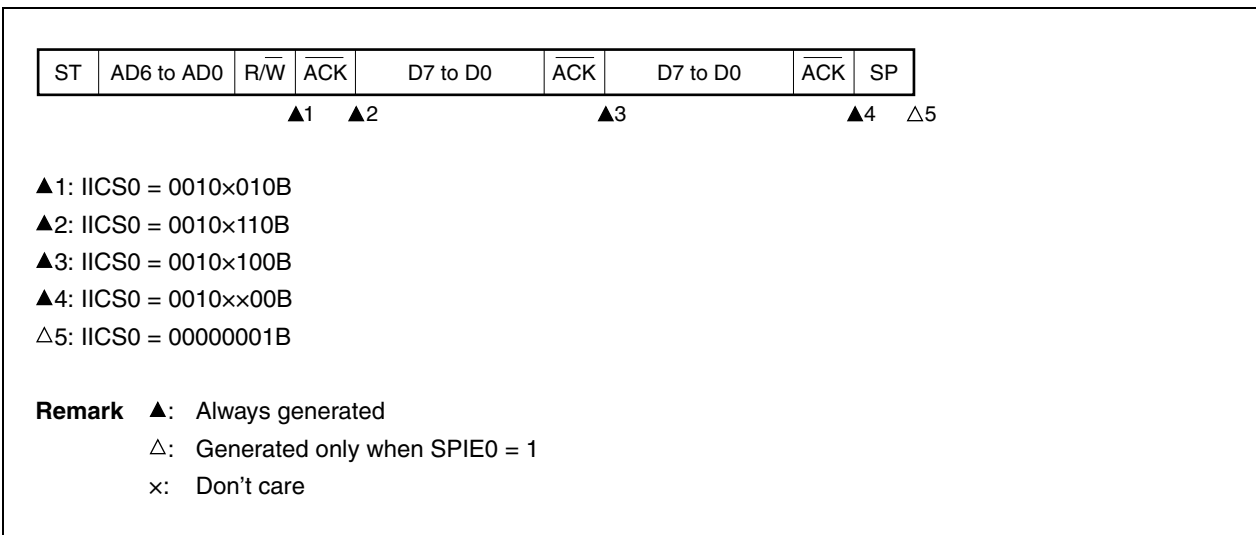

(b) Start ~ Code ~ Data ~ Start ~ Address ~ Data ~ Stop

(i) When WTIM0 = 0 (after restart, matches SVA0)

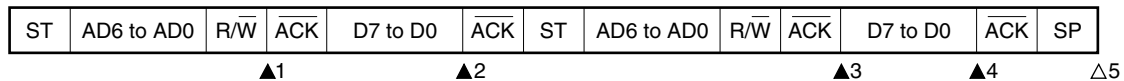

- ▲1: IICS0 = 0010x010B
- ▲2: IICS0 = 0010x000B
- ▲3: IICS0 = 0001x110B
- ▲4: IICS0 = 0001x000B
- △5: IICS0 = 00000001B

Remark ▲: Always generated
 △: Generated only when SPIE0 = 1
 x: Don't care

(ii) When WTIM0 = 1 (after restart, matches SVA0)

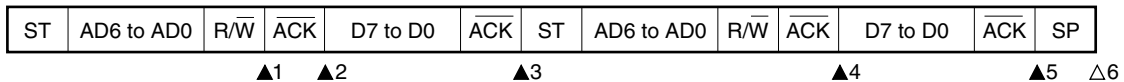

- ▲1: IICS0 = 0010x010B
- ▲2: IICS0 = 0010x110B
- ▲3: IICS0 = 0010xx00B
- ▲4: IICS0 = 0001x110B
- ▲5: IICS0 = 0001xx00B
- △6: IICS0 = 00000001B

Remark ▲: Always generated
 △: Generated only when SPIE0 = 1
 x: Don't care

(c) Start ~ Code ~ Data ~ Start ~ Code ~ Data ~ Stop

(i) When WTIM0 = 0 (after restart, extension code reception)

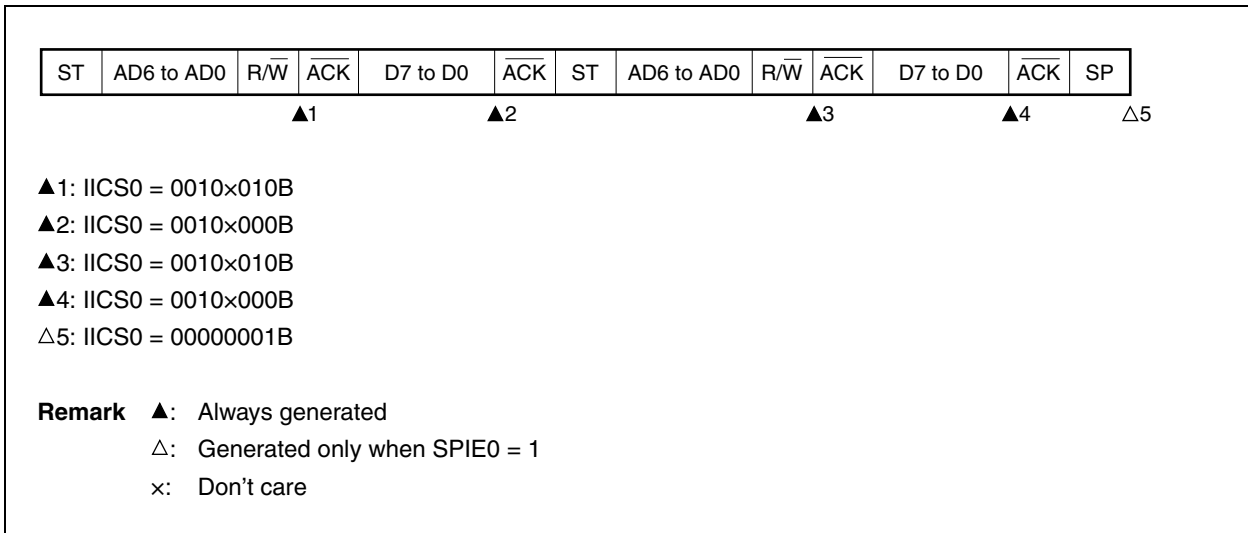

(ii) When WTIM0 = 1 (after restart, extension code reception)

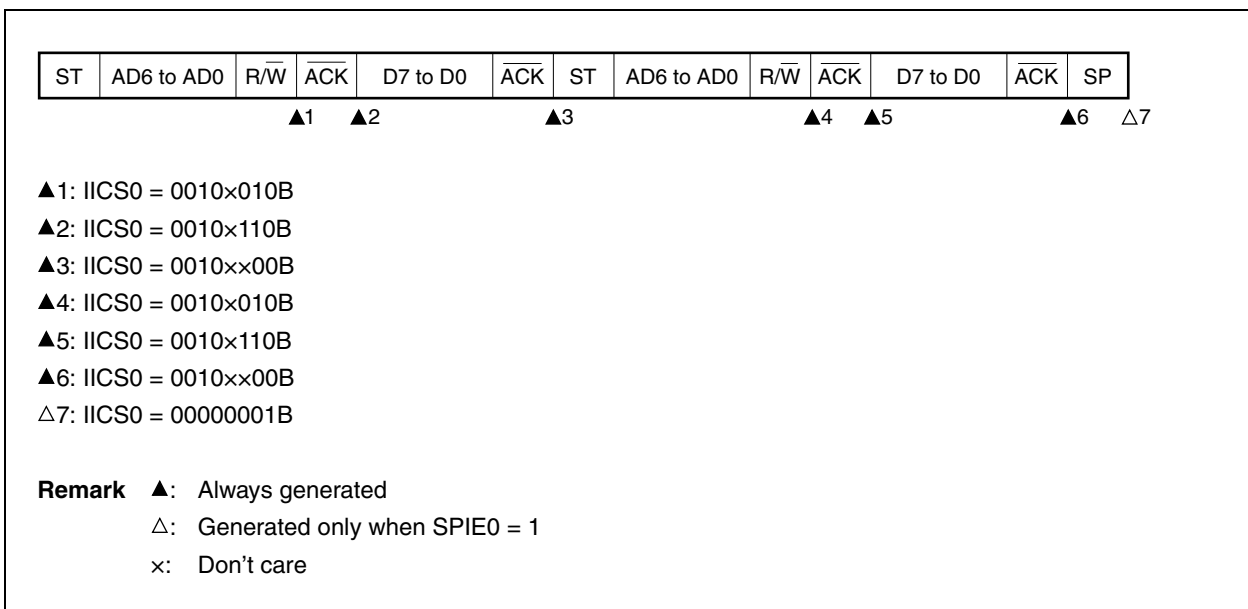

(d) Start ~ Code ~ Data ~ Start ~ Address ~ Data ~ Stop

(i) When WTIM0 = 0 (after restart, does not match address (= not extension code))

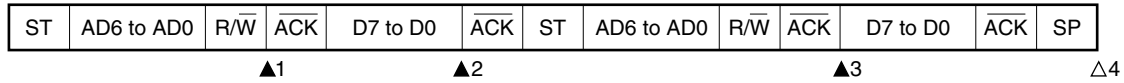

▲1: IICS0 = 00100010B

▲2: IICS0 = 00100000B

▲3: IICS0 = 00000110B

△4: IICS0 = 00000001B

Remark ▲: Always generated

△: Generated only when SPIE0 = 1

x: Don't care

(ii) When WTIM0 = 1 (after restart, does not match address (= not extension code))

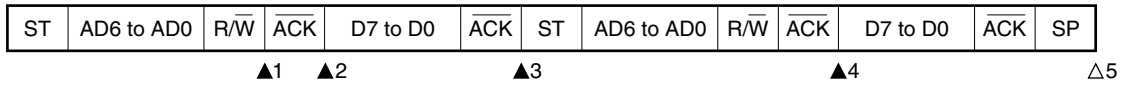

▲1: IICS0 = 00100010B

▲2: IICS0 = 00100110B

▲3: IICS0 = 00100x00B

▲4: IICS0 = 00000110B

△5: IICS0 = 00000001B

Remark ▲: Always generated

△: Generated only when SPIE0 = 1

x: Don't care

(4) Operation without communication

(a) Start ~ Code ~ Data ~ Data ~ Stop

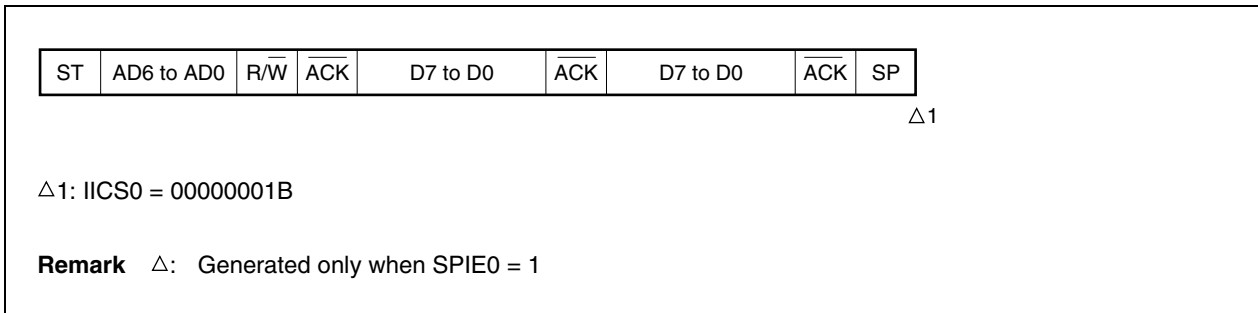

(5) Arbitration loss operation (operation as slave after arbitration loss)

When the device is used as a master in a multi-master system, read the MSTS0 bit each time interrupt request signal INTIIC0 has occurred to check the arbitration result.

(a) When arbitration loss occurs during transmission of slave address data

(i) When WTIM0 = 0

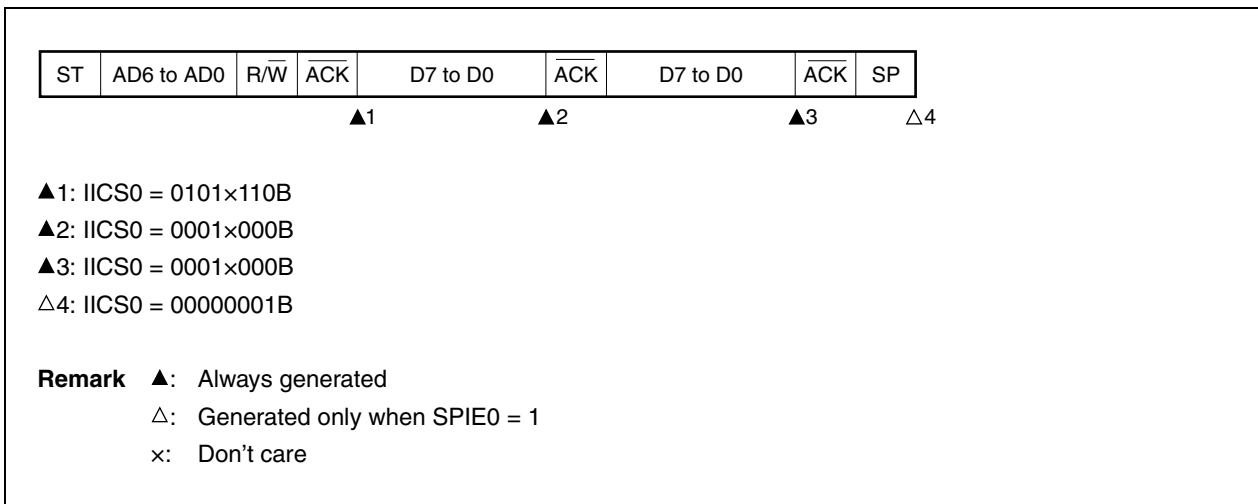

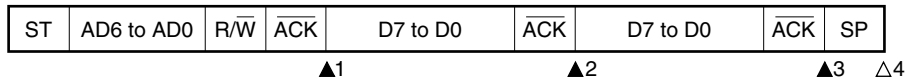
(ii) When $WTIM0 = 1$ 

▲1: IICS0 = 0101x110B

▲2: IICS0 = 0001x100B

▲3: IICS0 = 0001x×00B

△4: IICS0 = 00000001B

Remark ▲: Always generated

△: Generated only when SPIE0 = 1

x: Don't care

(b) When arbitration loss occurs during transmission of extension code

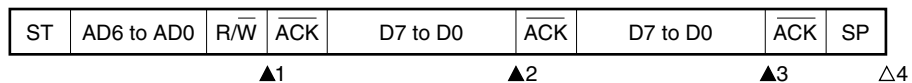
(i) When $WTIM0 = 0$ 

▲1: IICS0 = 0110x010B

▲2: IICS0 = 0010x000B

▲3: IICS0 = 0010x000B

△4: IICS0 = 00000001B

Remark ▲: Always generated

△: Generated only when SPIE0 = 1

x: Don't care

(ii) When WTIM0 = 1

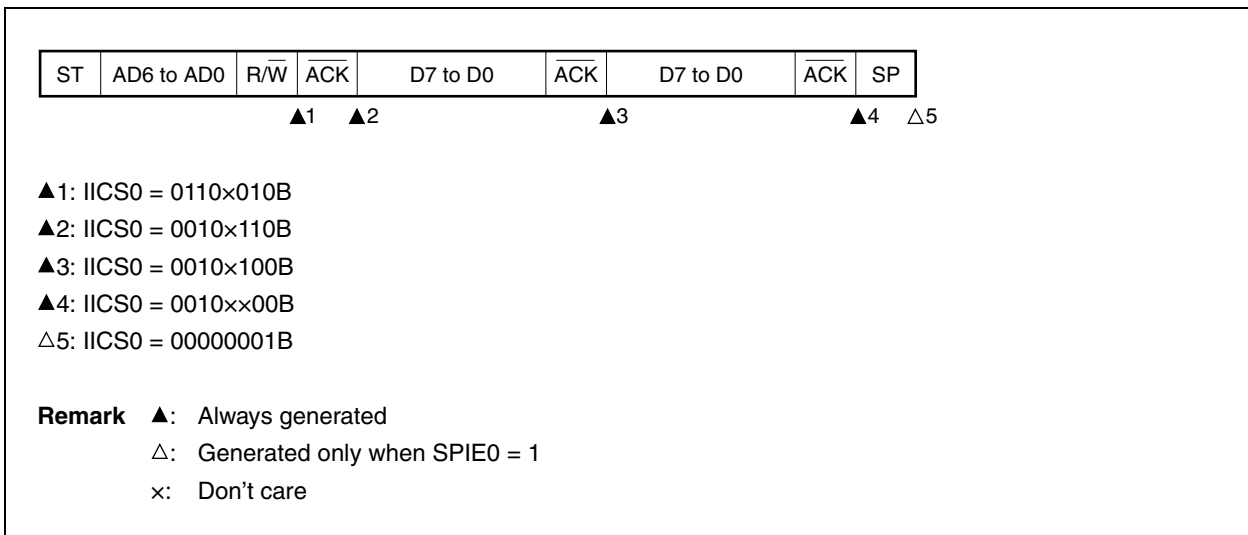

(6) Operation when arbitration loss occurs (no communication after arbitration loss)

When the device is used as a master in a multi-master system, read the MSTS0 bit each time interrupt request signal INTIIC0 has occurred to check the arbitration result.

(a) When arbitration loss occurs during transmission of slave address data (when WTIM0 = 1)

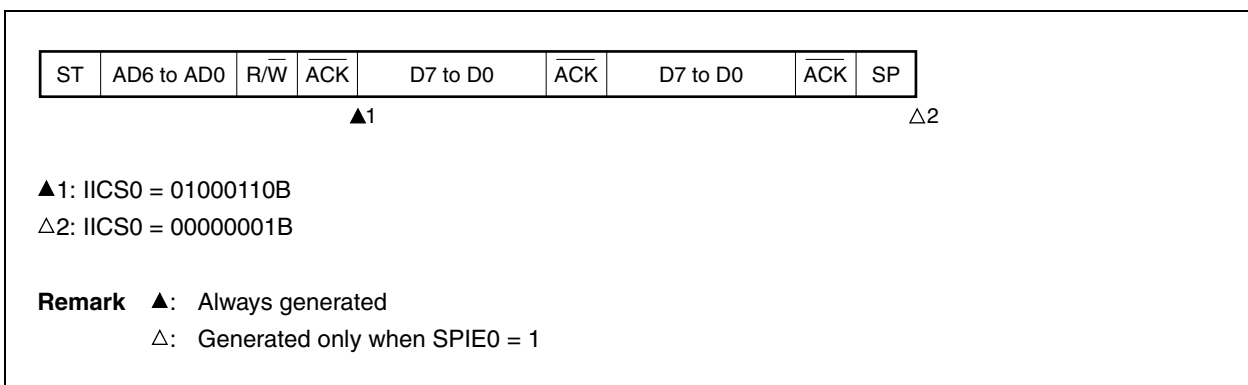

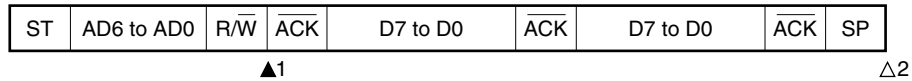
(b) When arbitration loss occurs during transmission of extension code

▲1: IIC0 = 0110x010B

Sets LREL0 = 1 by software

△2: IIC0 = 00000001B

Remark ▲: Always generated

△: Generated only when SPIE0 = 1

x: Don't care

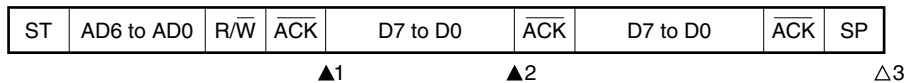
(c) When arbitration loss occurs during transmission of data**(i) When WTIM0 = 0**

▲1: IIC0 = 10001110B

▲2: IIC0 = 01000000B

△3: IIC0 = 00000001B

Remark ▲: Always generated

△: Generated only when SPIE0 = 1

(ii) When $WTIM0 = 1$

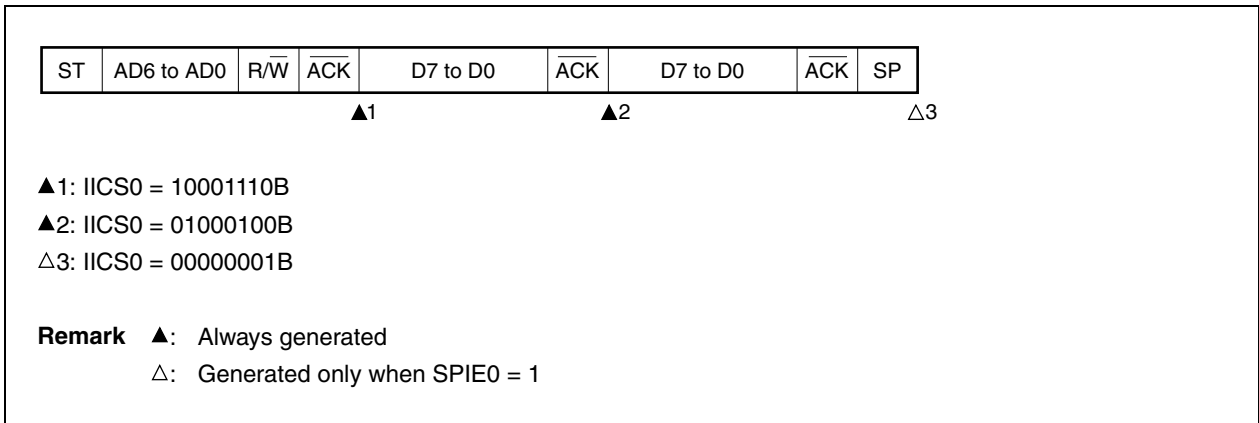

(d) When loss occurs due to restart condition during data transfer

(i) Not extension code (Example: unmatches with SVA0)

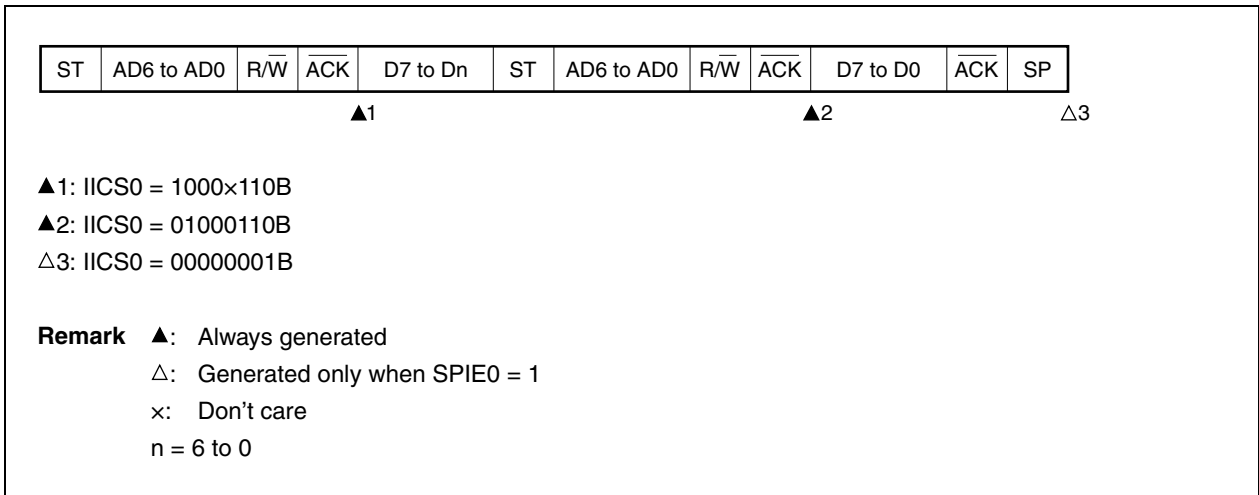

(ii) Extension code

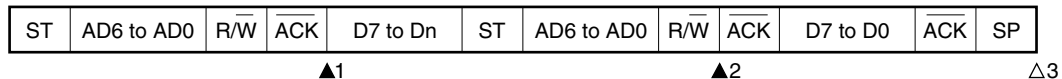

▲1: IICS0 = 1000x110B

▲2: IICS0 = 01100010B

Sets LREL0 = 1 by software

△3: IICS0 = 00000001B

Remark ▲: Always generated

△: Generated only when SPIE0 = 1

x: Don't care

n = 6 to 0

(e) When loss occurs due to stop condition during data transfer

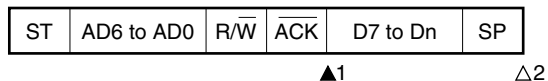

▲1: IICS0 = 10000110B

△2: IICS0 = 01000001B

Remark ▲: Always generated

△: Generated only when SPIE0 = 1

x: Don't care

n = 6 to 0

(f) When arbitration loss occurs due to low-level data when attempting to generate a restart condition

(i) When $WTIM0 = 0$

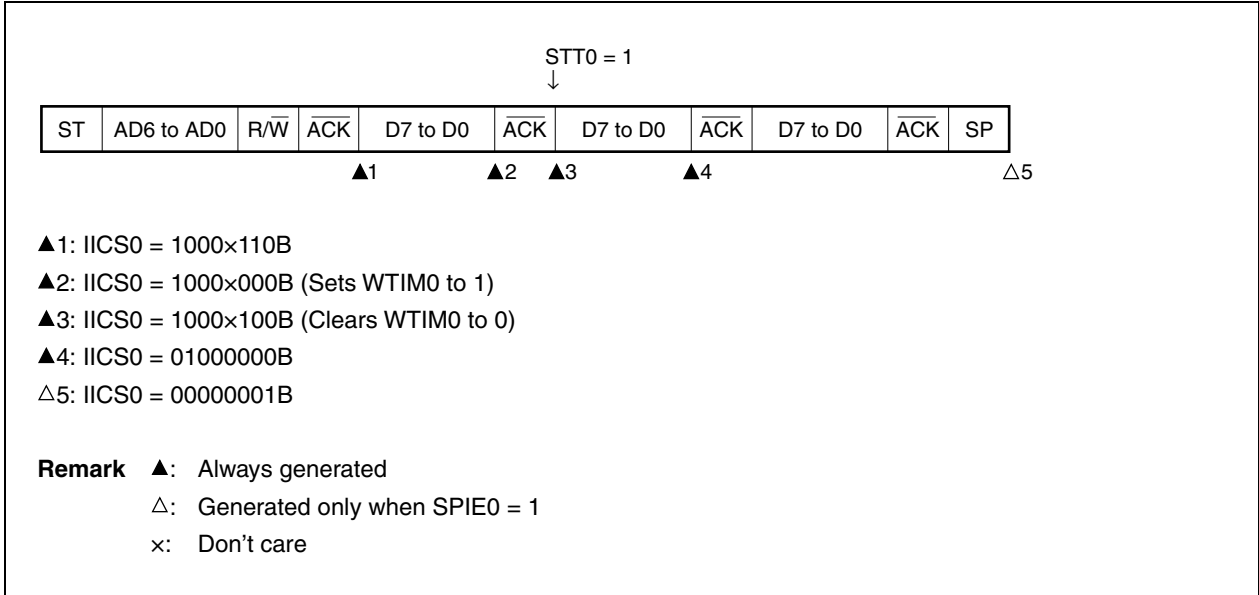

(ii) When $WTIM0 = 1$

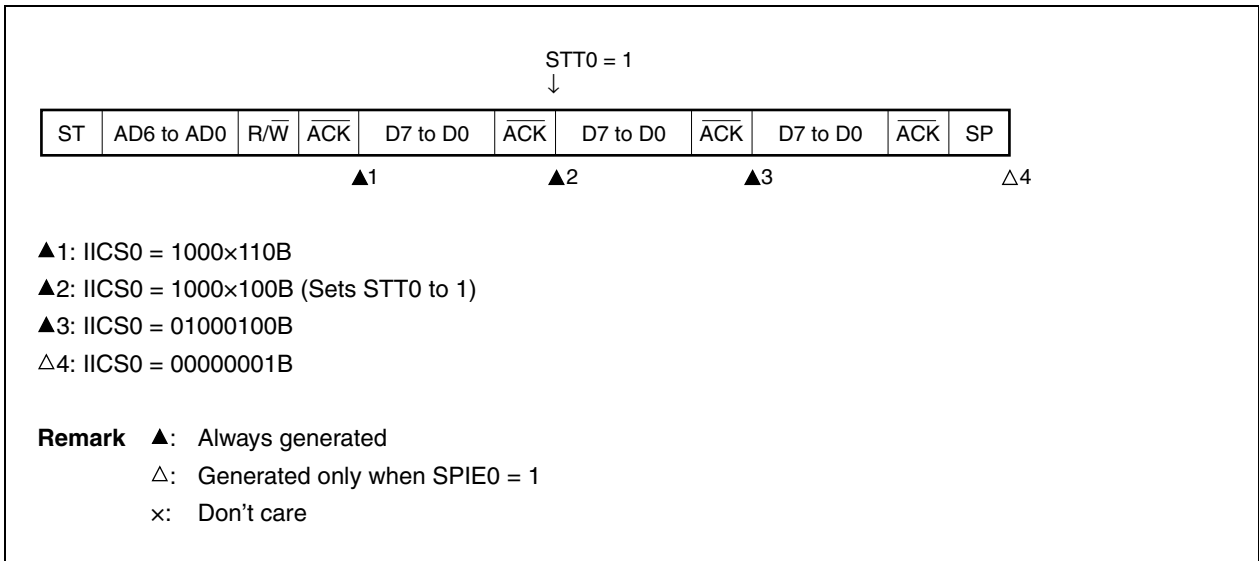

(g) When arbitration loss occurs due to a stop condition when attempting to generate a restart condition

(i) When $WTIM0 = 0$

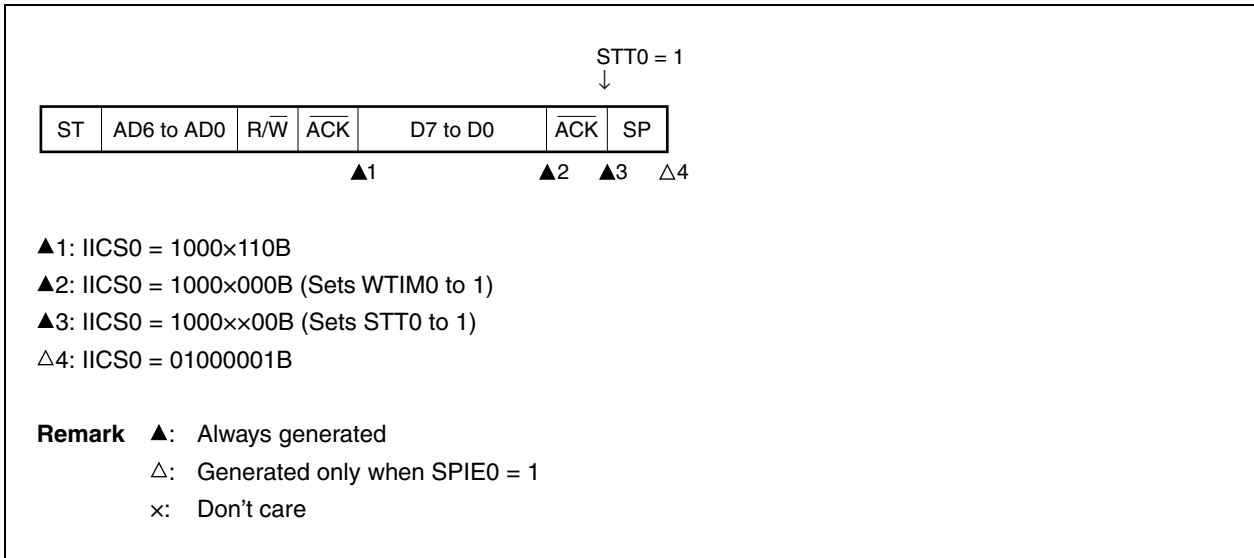

(ii) When $WTIM0 = 1$

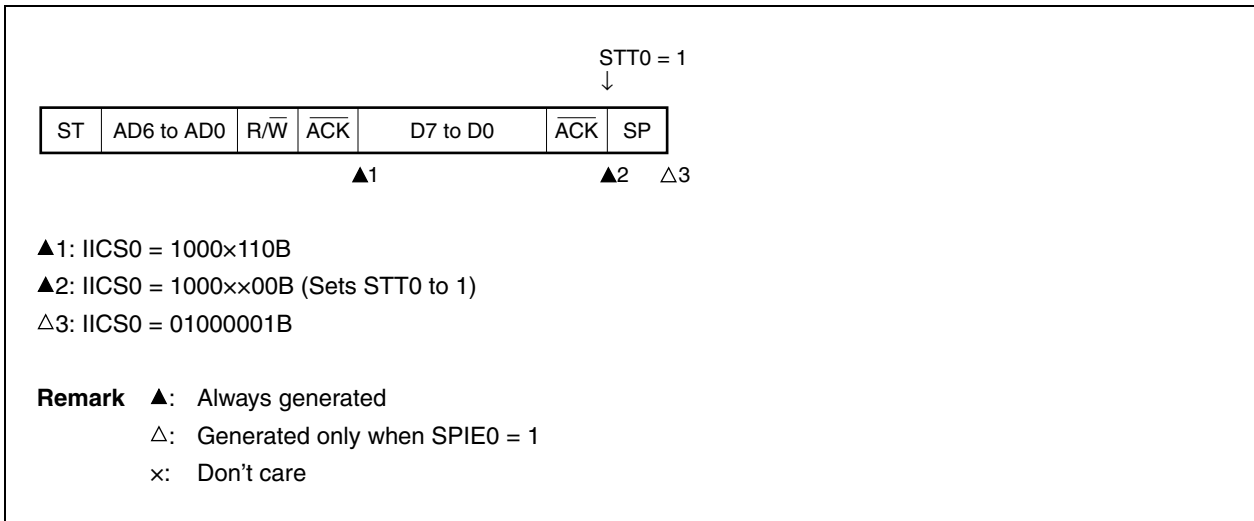

(h) When arbitration loss occurs due to low-level data when attempting to generate a stop condition

(i) When WTIM0 = 0

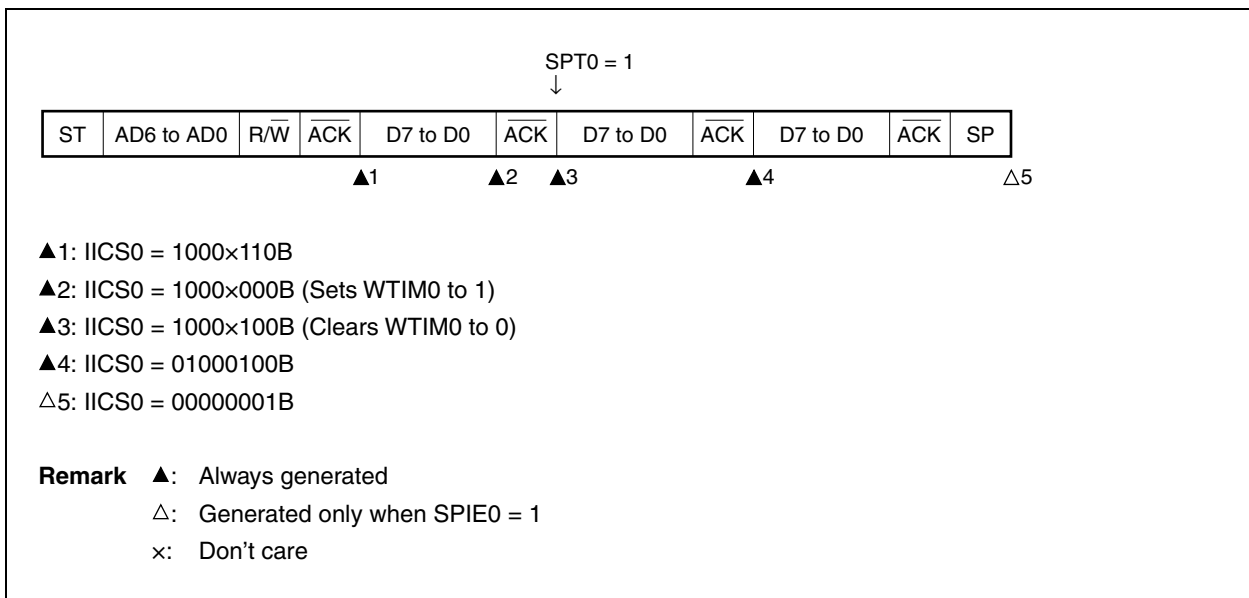

(ii) When WTIM0 = 1

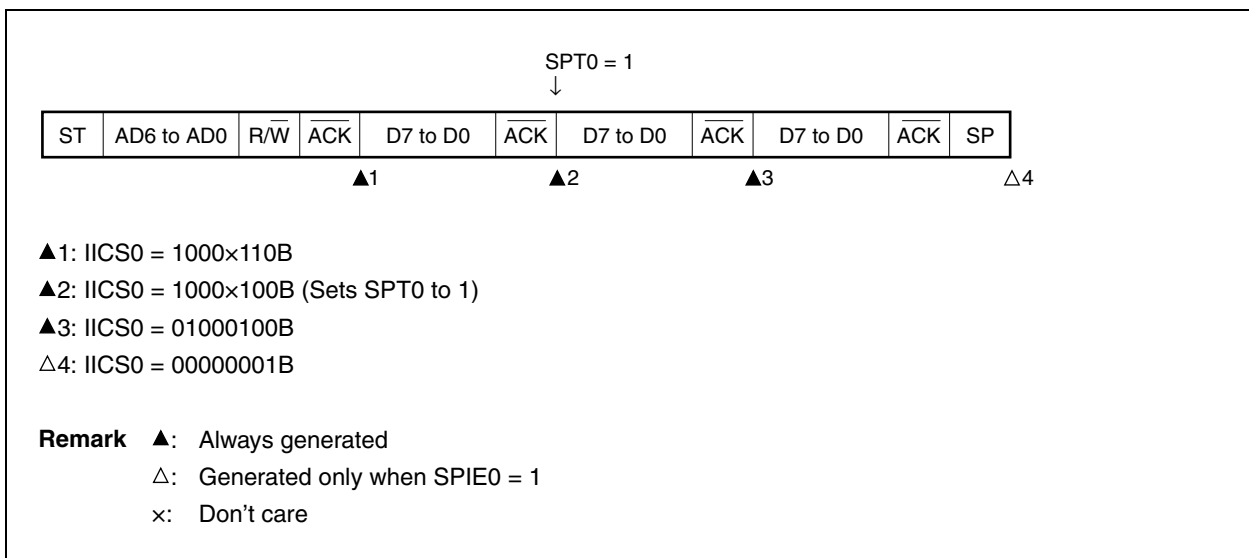

14.6 Timing Charts

When using the I²C bus mode, the master device outputs an address via the serial bus to select one of several slave devices as its communication partner.

After outputting the slave address, the master device transmits the TRC0 bit (bit 3 of IIC status register 0 (IICS0)), which specifies the data transfer direction, and then starts serial communication with the slave device.

Figures 14-27 and 14-28 show timing charts of the data communication.

IIC shift register 0 (IIC0)'s shift operation is synchronized with the falling edge of the serial clock (SCL0). The transmit data is transferred to the SO0 latch and is output (MSB first) via the SDA0 pin.

Data input via the SDA0 pin is captured into IIC0 at the rising edge of SCL0.

**Figure 14-27. Example of Master to Slave Communication
(When 9-Clock Wait Is Selected for Both Master and Slave) (1/3)**

(1) Start condition ~ address

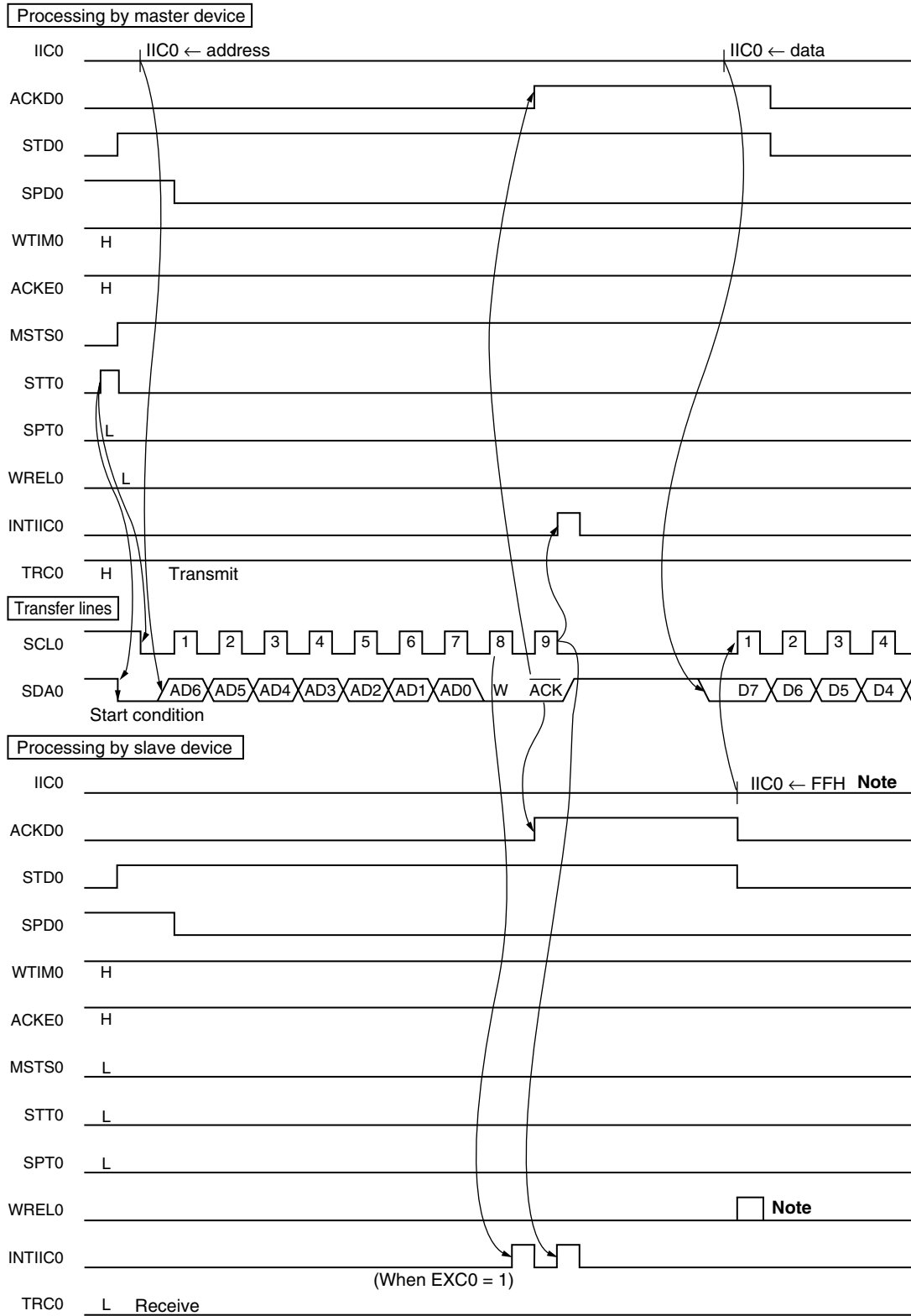

Note To cancel slave wait, write "FFH" to IIC0 or set WREL0.

Figure 14-27. Example of Master to Slave Communication
(When 9-Clock Wait Is Selected for Both Master and Slave) (2/3)

(2) Data

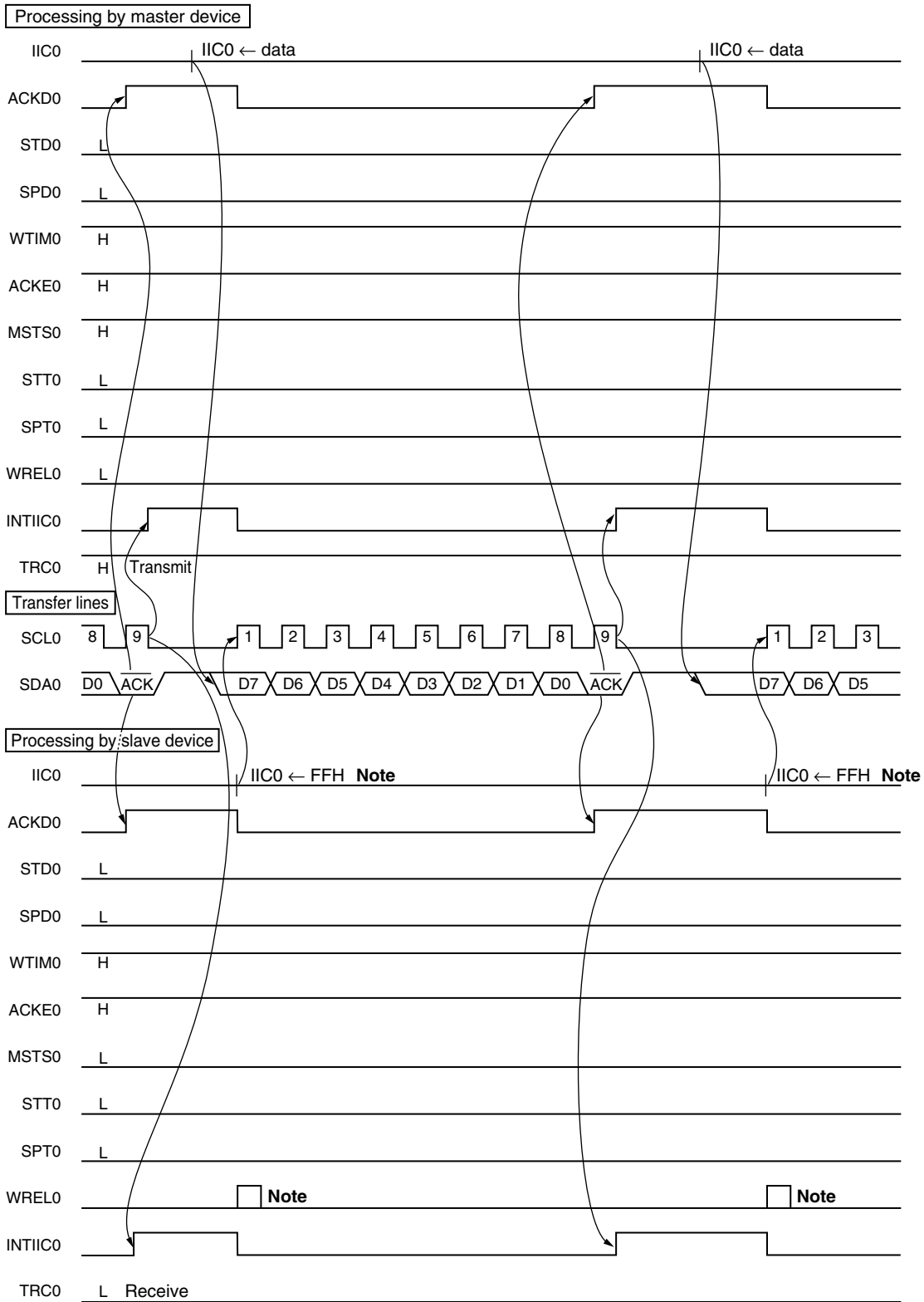

Note To cancel slave wait, write "FFH" to IIC0 or set WRELO.

**Figure 14-27. Example of Master to Slave Communication
(When 9-Clock Wait Is Selected for Both Master and Slave) (3/3)**

(3) Stop condition

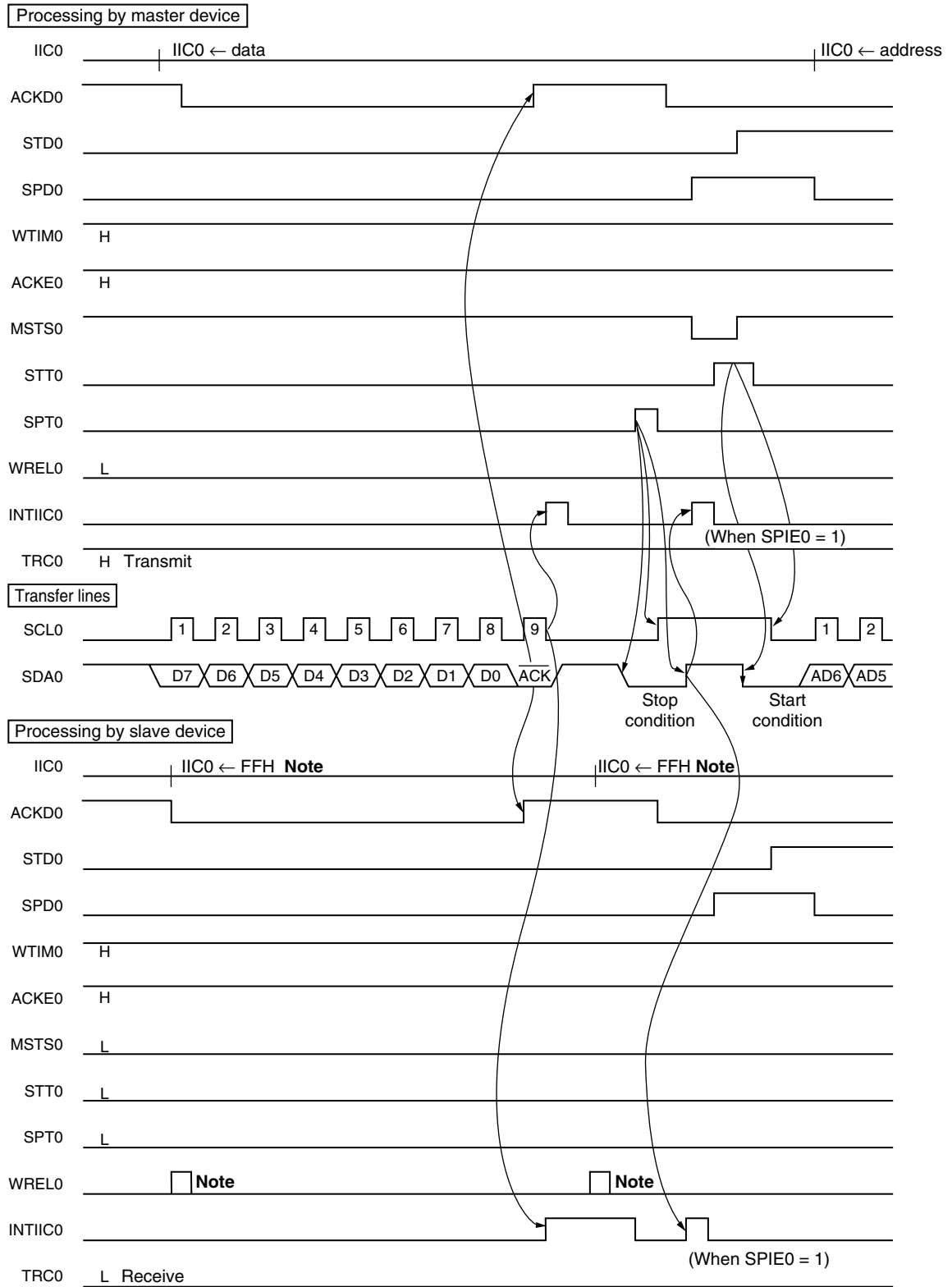

Note To cancel slave wait, write "FFH" to IIC0 or set WRELO.

Figure 14-28. Example of Slave to Master Communication
 (When 8-Clock Wait Is Selected for Master, 9-Clock Wait Is Selected for Slave) (1/3)

(1) Start condition ~ address

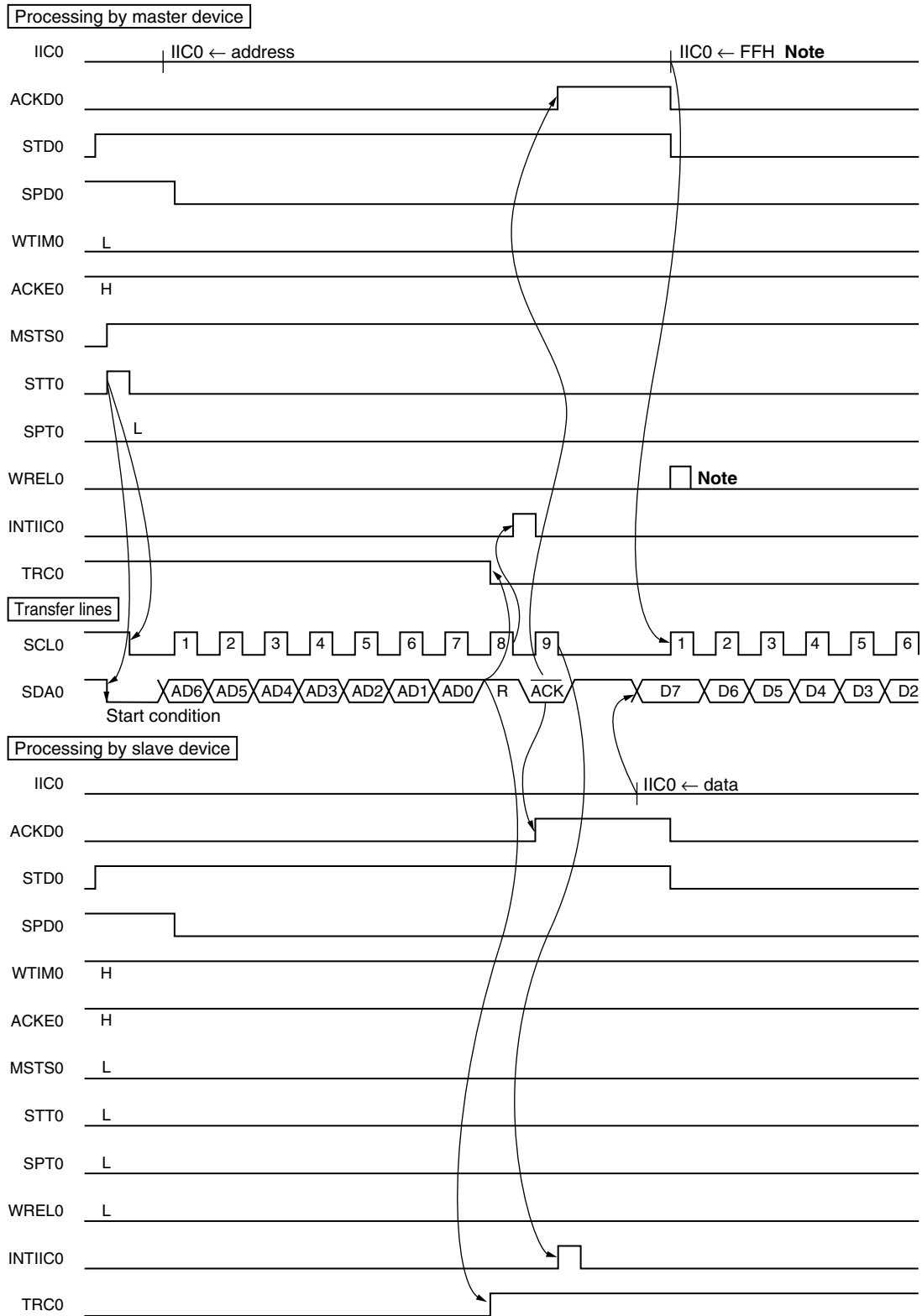

Note To cancel master wait, write "FFH" to IIC0 or set WREL0.

Figure 14-28. Example of Slave to Master Communication
 (When 8-Clock Wait Is Selected for Master, 9-Clock Wait Is Selected for Slave) (2/3)

(2) Data

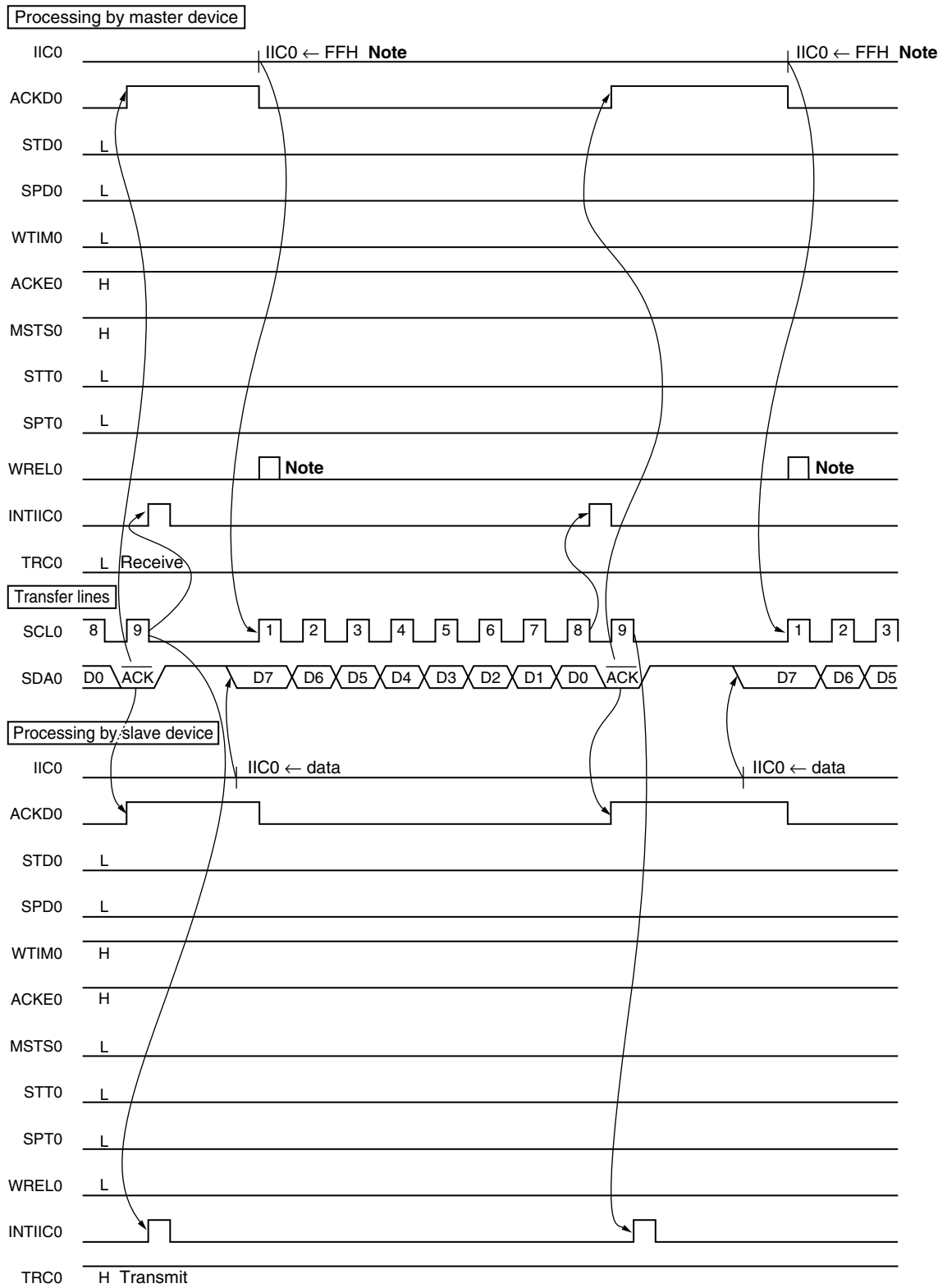

Note To cancel master wait, write "FFH" to IIC0 or set WREL0.

Figure 14-28. Example of Slave to Master Communication
 (When 8-Clock and 9-Clock Wait Is Selected for Master, 9-Clock Wait Is Selected for Slave) (3/3)

(3) Stop condition

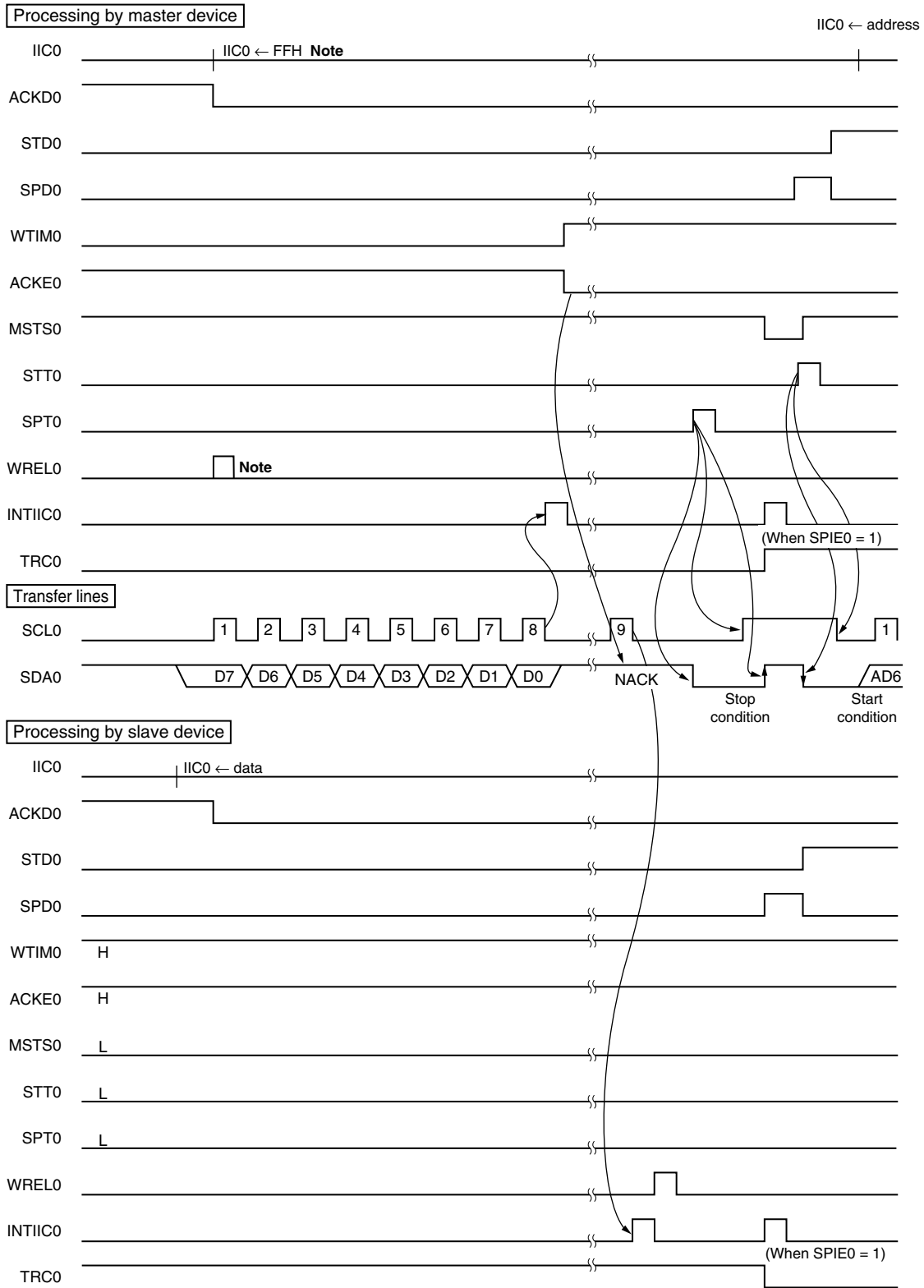

Note To cancel master wait, write “FFH” to IIC0 or set WRELO.

CHAPTER 15 INTERRUPT FUNCTIONS

15.1 Interrupt Function Types

The following two types of interrupt functions are used.

(1) Maskable interrupts

These interrupts undergo mask control. Maskable interrupts can be divided into a high interrupt priority group and a low interrupt priority group by setting the priority specification flag registers (PR0L, PR0H, PR1L, PR1H).

Multiple interrupt servicing can be applied to low-priority interrupts when high-priority interrupts are generated. If two or more interrupt requests, each having the same priority, are simultaneously generated, then they are processed according to the priority of vectored interrupt servicing. For the priority order, see **Table 15-1**.

A standby release signal is generated and STOP and HALT modes are released.

External interrupt requests and internal interrupt requests are provided as maskable interrupts.

External: 6, internal: 14

(2) Software interrupt

This is a vectored interrupt generated by executing the BRK instruction. It is acknowledged even when interrupts are disabled. The software interrupt does not undergo interrupt priority control.

15.2 Interrupt Sources and Configuration

The 78K0/KB2 has a total of 21 interrupt sources including maskable interrupts and software interrupts. In addition, they also have up to four reset sources (see **Table 15-1**).

Table 15-1. Interrupt Source List

Interrupt Type	Default Priority ^{Note 1}	Interrupt Source		Internal/ External	Vector Table Address	Basic Configuration Type ^{Note 2}
		Name	Trigger			
Maskable	0	INTLVI	Low-voltage detection ^{Note 3}	Internal	0004H	(A)
	1	INTP0	Pin input edge detection	External	0006H	(B)
	2	INTP1			0008H	
	3	INTP2			000AH	
	4	INTP3			000CH	
	5	INTP4			000EH	
	6	INTP5			0010H	
	7	INTSRE6	UART6 reception error generation	Internal	0012H	(A)
	8	INTSR6	End of UART6 reception		0014H	
	9	INTST6	End of UART6 transmission		0016H	
	10	INTCSI10/ INTST0	End of CSI10 communication/end of UART0 transmission		0018H	
	11	INTTMH1	Match between TMH1 and CMP01 (when compare register is specified)		001AH	
	12	INTTMH0	Match between TMH0 and CMP00 (when compare register is specified)		001CH	
	13	INTTM50	Match between TM50 and CR50 (when compare register is specified)		001EH	
	14	INTTM000	Match between TM00 and CR000 (when compare register is specified), TI010 pin valid edge detection (when capture register is specified)		0020H	
	15	INTTM010	Match between TM00 and CR010 (when compare register is specified), TI000 pin valid edge detection (when capture register is specified)		0022H	
	16	INTAD	End of A/D conversion		0024H	
	17	INTSR0	End of UART0 reception or reception error generation		0026H	
	18	INTTM51 ^{Note 4}	Match between TM51 and CR51 (when compare register is specified)		002AH	
19	INTIIC0	End of IIC0 communication	0034H			
Software	–	BRK	BRK instruction execution	–	003EH	(D)
Reset	–	RESET	$\overline{\text{RESET}}$ pin input	–	0000H	–
		POC	Power-on clear			
		LVI	Low-voltage detection ^{Note 5}			
		WDT	WDT overflow			

- Notes**
1. The default priority determines the sequence of processing vectored interrupts if two or more maskable interrupts occur simultaneously. Zero indicates the highest priority and 19 indicates the lowest priority.
 2. Basic configuration types (A) to (C) correspond to (A) to (C) in Figure 15-1.
 3. When bit 1 (LVIMD) of the low-voltage detection register (LVIM) is cleared to 0.
 4. When the 8-bit timer/event counter 51 is used in the carrier generator mode, the interrupt source is INTTM5H1 (see **Figure 8-13 Transfer Timing**).
 5. When bit 1 (LVIMD) of the low-voltage detection register (LVIM) is set to 1.

<R>

Figure 15-1. Basic Configuration of Interrupt Function

(A) Internal maskable interrupt

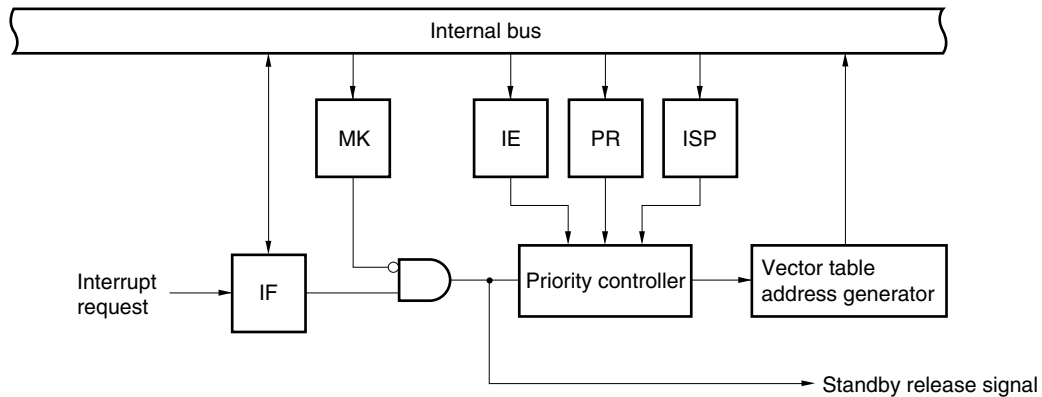

(B) External maskable interrupt (INTP0 to INTP5)

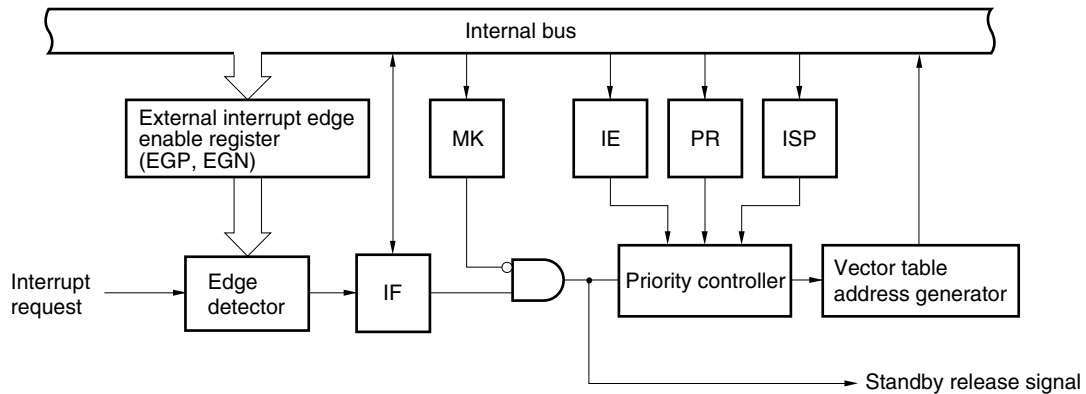

- IF: Interrupt request flag
- IE: Interrupt enable flag
- ISP: In-service priority flag
- MK: Interrupt mask flag
- PR: Priority specification flag

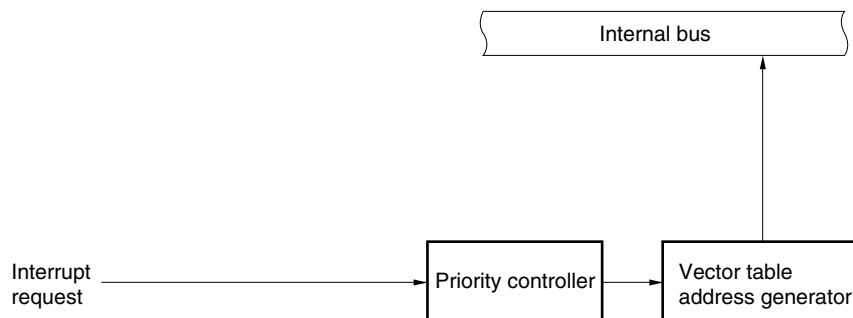
(C) Software interrupt

- IF: Interrupt request flag
- IE: Interrupt enable flag
- ISP: In-service priority flag
- MK: Interrupt mask flag
- PR: Priority specification flag

15.3 Registers Controlling Interrupt Functions

The following 6 types of registers are used to control the interrupt functions.

- Interrupt request flag register (IF0L, IF0H, IF1L, IF1H)
- Interrupt mask flag register (MK0L, MK0H, MK1L, MK1H)
- Priority specification flag register (PR0L, PR0H, PR1L, PR1H)
- External interrupt rising edge enable register (EGP)
- External interrupt falling edge enable register (EGN)
- Program status word (PSW)

Table 15-2 shows a list of interrupt request flags, interrupt mask flags, and priority specification flags corresponding to interrupt request sources.

Table 15-2. Flags Corresponding to Interrupt Request Sources

Interrupt Source	Interrupt Request Flag		Interrupt Mask Flag		Priority Specification Flag				
		Register		Register		Register			
INTLVI	LVIF	IF0L	LVIMK	MK0L	LVIPR	PR0L			
INTP0	PIF0		PMK0		PPR0				
INTP1	PIF1		PMK1		PPR1				
INTP2	PIF2		PMK2		PPR2				
INTP3	PIF3		PMK3		PPR3				
INTP4	PIF4		PMK4		PPR4				
INTP5	PIF5		PMK5		PPR5				
INTSRE6	SREIF6		SREMK6		SREPR6				
INTSR6	SRIF6	IF0H	SRMK6	MK0H	SRPR6	PR0H			
INTST6	STIF6		STMK6		STPR6				
INTCSI10	CSIF10 <small>Note 1</small>		DUALIF0 <small>Note 1</small>		CSIMK10 <small>Note 2</small>		DUALMK0 <small>Note 2</small>	CSIPR10 <small>Note 3</small>	DUALPR0 <small>Note 3</small>
INTST0	STIF0 <small>Note 1</small>				STMK0 <small>Note 2</small>			STPR0 <small>Note 3</small>	
INTTMH1	TMIFH1				TMMKH1			TMPRH1	
INTTMH0	TMIFH0				TMMKH0			TMPRH0	
INTTM50	TMIF50				TMMK50			TMPR50	
INTTM000	TMIF000				TMMK000			TMPR000	
INTTM010	TMIF010				TMMK010			TMPR010	
INTAD	ADIF		IF1L		ADMK		MK1L	ADPR	PR1L
INTSR0	SRIF0	SRMK0		SRPR0					
INTTM51 <small>Note 4</small>	TMIF51	TMMK51		TMPR51					
INTIIC0	IICIF0	IF1H		IICMK0	MK1H	IICPR0		PR1H	

- Notes**
1. If either interrupt source INTCSI10 or INTST0 is generated, bit 2 of IF0H is set (1).
 2. Bit 2 of MK0H supports both interrupt sources INTCSI10 and INTST0.
 3. Bit 2 of PR0H supports both interrupt sources INTCSI10 and INTST0.
 4. When the 8-bit timer/event counter 51 is used in the carrier generator mode, the interrupt source is INTTM5H1 (see **Figure 8-13 Transfer Timing**).

<R>

(1) Interrupt request flag registers (IF0L, IF0H, IF1L, IF1H)

The interrupt request flags are set to 1 when the corresponding interrupt request is generated or an instruction is executed. They are cleared to 0 when an instruction is executed upon acknowledgment of an interrupt request or upon reset signal generation.

When an interrupt is acknowledged, the interrupt request flag is automatically cleared and then the interrupt routine is entered.

IF0L, IF0H, IF1L, and IF1H are set by a 1-bit or 8-bit memory manipulation instruction. When IF0L and IF0H, and IF1L and IF1H are combined to form 16-bit registers IF0 and IF1, they are set by a 16-bit memory manipulation instruction.

Reset signal generation sets these registers to 00H.

Figure 15-2. Format of Interrupt Request Flag Registers (IF0L, IF0H, IF1L, IF1H)

Address: FFE0H After reset: 00H R/W

Symbol	<7>	<6>	<5>	<4>	<3>	<2>	<1>	<0>
IF0L	SREIF6	PIF5	PIF4	PIF3	PIF2	PIF1	PIF0	LVIF

Address: FFE1H After reset: 00H R/W

Symbol	<7>	<6>	<5>	<4>	<3>	<2>	<1>	<0>
IF0H	TMIF010	TMIF000	TMIF50	TMIFH0	TMIFH1	DUALIF0 CSIIF10 STIF0	STIF6	SRIF6

Address: FFE2H After reset: 00H R/W

Symbol	7	6	5	4	<3>	2	<1>	<0>
IF1L	0	0	0	0	TMIF51	0	SRIF0	ADIF

Address: FFE3H After reset: 00H R/W

Symbol	7	6	5	4	3	2	1	<0>
IF1H	0	0	0	0	0	0	0	IICIF0

XXIFX	Interrupt request flag
0	No interrupt request signal is generated
1	Interrupt request is generated, interrupt request status

- Cautions**
1. Be sure to clear bits 2, 4 to 7 of IF1L and bits 1 to 7 of IF1H to 0.
 2. When operating a timer, serial interface, or A/D converter after standby release, operate it once after clearing the interrupt request flag. An interrupt request flag may be set by noise.

Cautions 3. When manipulating a flag of the interrupt request flag register, use a 1-bit memory manipulation instruction (CLR1). When describing in C language, use a bit manipulation instruction such as “IF0L.0 = 0;” or “_asm(“clr1 IF0L, 0”);” because the compiled assembler must be a 1-bit memory manipulation instruction (CLR1).

If a program is described in C language using an 8-bit memory manipulation instruction such as “IF0L &= 0xfe;” and compiled, it becomes the assembler of three instructions.

```
mov a, IF0L
and a, #0FEH
mov IF0L, a
```

In this case, even if the request flag of another bit of the same interrupt request flag register (IF0L) is set to 1 at the timing between “mov a, IF0L” and “mov IF0L, a”, the flag is cleared to 0 at “mov IF0L, a”. Therefore, care must be exercised when using an 8-bit memory manipulation instruction in C language.

(2) Interrupt mask flag registers (MK0L, MK0H, MK1L, MK1H)

The interrupt mask flags are used to enable/disable the corresponding maskable interrupt servicing.

MK0L, MK0H, MK1L, and MK1H are set by a 1-bit or 8-bit memory manipulation instruction. When MK0L and MK0H, and MK1L and MK1H are combined to form 16-bit registers MK0 and MK1, they are set by a 16-bit memory manipulation instruction.

Reset signal generation sets these registers to FFH.

Figure 15-3. Format of Interrupt Mask Flag Registers (MK0L, MK0H, MK1L, MK1H)

Address: FFE4H After reset: FFH R/W

Symbol	<7>	<6>	<5>	<4>	<3>	<2>	<1>	<0>
MK0L	SREMK6	PMK5	PMK4	PMK3	PMK2	PMK1	PMK0	LVIMK

Address: FFE5H After reset: FFH R/W

Symbol	<7>	<6>	<5>	<4>	<3>	<2>	<1>	<0>
MK0H	TMMK010	TMMK000	TMMK50	TMMKH0	TMMKH1	DUALMK0 CSIMK0 STMK0	STMK6	SRMK6

Address: FFE6H After reset: FFH R/W

Symbol	7	6	5	4	<3>	2	<1>	<0>
MK1L	1	1	1	1	TMMK51	1	SRMK0	ADMK

Address: FFE7H After reset: FFH R/W

Symbol	7	6	5	4	3	2	1	<0>
MK1H	1	1	1	1	1	1	1	IICMK0

XXMKX	Interrupt servicing control
0	Interrupt servicing enabled
1	Interrupt servicing disabled

Caution Be sure to set bits 2, 4 to 7 of MK1L and bits 1 to 7 of MK1H to 1.

(3) Priority specification flag registers (PR0L, PR0H, PR1L, PR1H)

The priority specification flag registers are used to set the corresponding maskable interrupt priority order. PR0L, PR0H, PR1L, and PR1H are set by a 1-bit or 8-bit memory manipulation instruction. If PR0L and PR0H, and PR1L and PR1H are combined to form 16-bit registers PR0 and PR1, they are set by a 16-bit memory manipulation instruction.

Reset signal generation sets these registers to FFH.

Figure 15-4. Format of Priority Specification Flag Registers (PR0L, PR0H, PR1L, PR1H)

Address: FFE8H After reset: FFH R/W

Symbol	<7>	<6>	<5>	<4>	<3>	<2>	<1>	<0>
PR0L	SREPR6	PPR5	PPR4	PPR3	PPR2	PPR1	PPR0	LVIPR

Address: FFE9H After reset: FFH R/W

Symbol	<7>	<6>	<5>	<4>	<3>	<2>	<1>	<0>
PR0H	TMPR010	TMPR000	TMPR50	TMPRH0	TMPRH1	DUALPR0 CSIPR10 STPR0	STPR6	SRPR6

Address: FFEAH After reset: FFH R/W

Symbol	7	6	5	4	<3>	2	<1>	<0>
PR1L	1	1	1	1	TMPR51	1	SRPR0	ADPR

Address: FFE BH After reset: FFH R/W

Symbol	7	6	5	4	3	2	1	<0>
PR1H	1	1	1	1	1	1	1	IICPR0

XXPRX	Priority level selection
0	High priority level
1	Low priority level

Caution Be sure to set bits 2, 4 to 7 of PR1L and bits 1 to 7 of PR1H to 1.

(4) External interrupt rising edge enable register (EGP), external interrupt falling edge enable register (EGN)

These registers specify the valid edge for INTP0 to INTP5.

EGP and EGN are set by a 1-bit or 8-bit memory manipulation instruction.

Reset signal generation sets these registers to 00H.

Figure 15-5. Format of External Interrupt Rising Edge Enable Register (EGP) and External Interrupt Falling Edge Enable Register (EGN)

Address: FF48H After reset: 00H R/W

Symbol	7	6	5	4	3	2	1	0
EGP	0	0	EGP5	EGP4	EGP3	EGP2	EGP1	EGP0

Address: FF49H After reset: 00H R/W

Symbol	7	6	5	4	3	2	1	0
EGN	0	0	EGN5	EGN4	EGN3	EGN2	EGN1	EGN0

EGPn	EGNn	INTPn pin valid edge selection (n = 0 to 5)
0	0	Edge detection disabled
0	1	Falling edge
1	0	Rising edge
1	1	Both rising and falling edges

Table 15-3 shows the ports corresponding to EGPn and EGNn.

Table 15-3. Ports Corresponding to EGPn and EGNn

Detection Enable Register		Edge Detection Port	Interrupt Request Signal
EGP0	EGN0	P120	INTP0
EGP1	EGN1	P30	INTP1
EGP2	EGN2	P31	INTP2
EGP3	EGN3	P32	INTP3
EGP4	EGN4	P33	INTP4
EGP5	EGN5	P16	INTP5

Caution Select the port mode by clearing EGPn and EGNn to 0 because an edge may be detected when the external interrupt function is switched to the port function.

Remark n = 0 to 5

(5) Program status word (PSW)

The program status word is a register used to hold the instruction execution result and the current status for an interrupt request. The IE flag that sets maskable interrupt enable/disable and the ISP flag that controls multiple interrupt servicing are mapped to the PSW.

Besides 8-bit read/write, this register can carry out operations using bit manipulation instructions and dedicated instructions (EI and DI). When a vectored interrupt request is acknowledged, if the BRK instruction is executed, the contents of the PSW are automatically saved into a stack and the IE flag is reset to 0. If a maskable interrupt request is acknowledged, the contents of the priority specification flag of the acknowledged interrupt are transferred to the ISP flag. The PSW contents are also saved into the stack with the PUSH PSW instruction. They are restored from the stack with the RETI, RETB, and POP PSW instructions. Reset signal generation sets PSW to 02H.

Figure 15-6. Format of Program Status Word

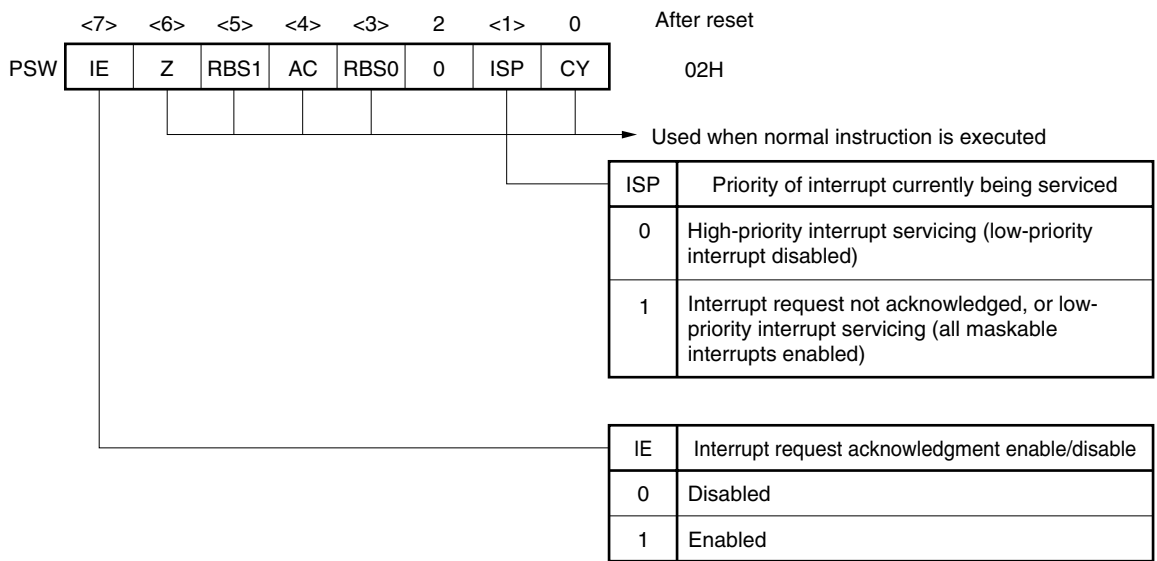

15.4 Interrupt Servicing Operations

15.4.1 Maskable interrupt acknowledgement

A maskable interrupt becomes acknowledgeable when the interrupt request flag is set to 1 and the mask (MK) flag corresponding to that interrupt request is cleared to 0. A vectored interrupt request is acknowledged if interrupts are in the interrupt enabled state (when the IE flag is set to 1). However, a low-priority interrupt request is not acknowledged during servicing of a higher priority interrupt request (when the ISP flag is reset to 0).

The times from generation of a maskable interrupt request until vectored interrupt servicing is performed are listed in Table 15-4 below.

For the interrupt request acknowledgement timing, see **Figures 15-8** and **15-9**.

Table 15-4. Time from Generation of Maskable Interrupt Until Servicing

	Minimum Time	Maximum Time ^{Note}
When $\times\times PR = 0$	7 clocks	32 clocks
When $\times\times PR = 1$	8 clocks	33 clocks

Note If an interrupt request is generated just before a divide instruction, the wait time becomes longer.

Remark 1 clock: $1/f_{CPU}$ (f_{CPU} : CPU clock)

If two or more maskable interrupt requests are generated simultaneously, the request with a higher priority level specified in the priority specification flag is acknowledged first. If two or more interrupts requests have the same priority level, the request with the highest default priority is acknowledged first.

An interrupt request that is held pending is acknowledged when it becomes acknowledgeable.

Figure 15-7 shows the interrupt request acknowledgement algorithm.

If a maskable interrupt request is acknowledged, the contents are saved into the stacks in the order of PSW, then PC, the IE flag is reset (0), and the contents of the priority specification flag corresponding to the acknowledged interrupt are transferred to the ISP flag. The vector table data determined for each interrupt request is the loaded into the PC and branched.

Restoring from an interrupt is possible by using the RETI instruction.

Figure 15-7. Interrupt Request Acknowledgement Processing Algorithm

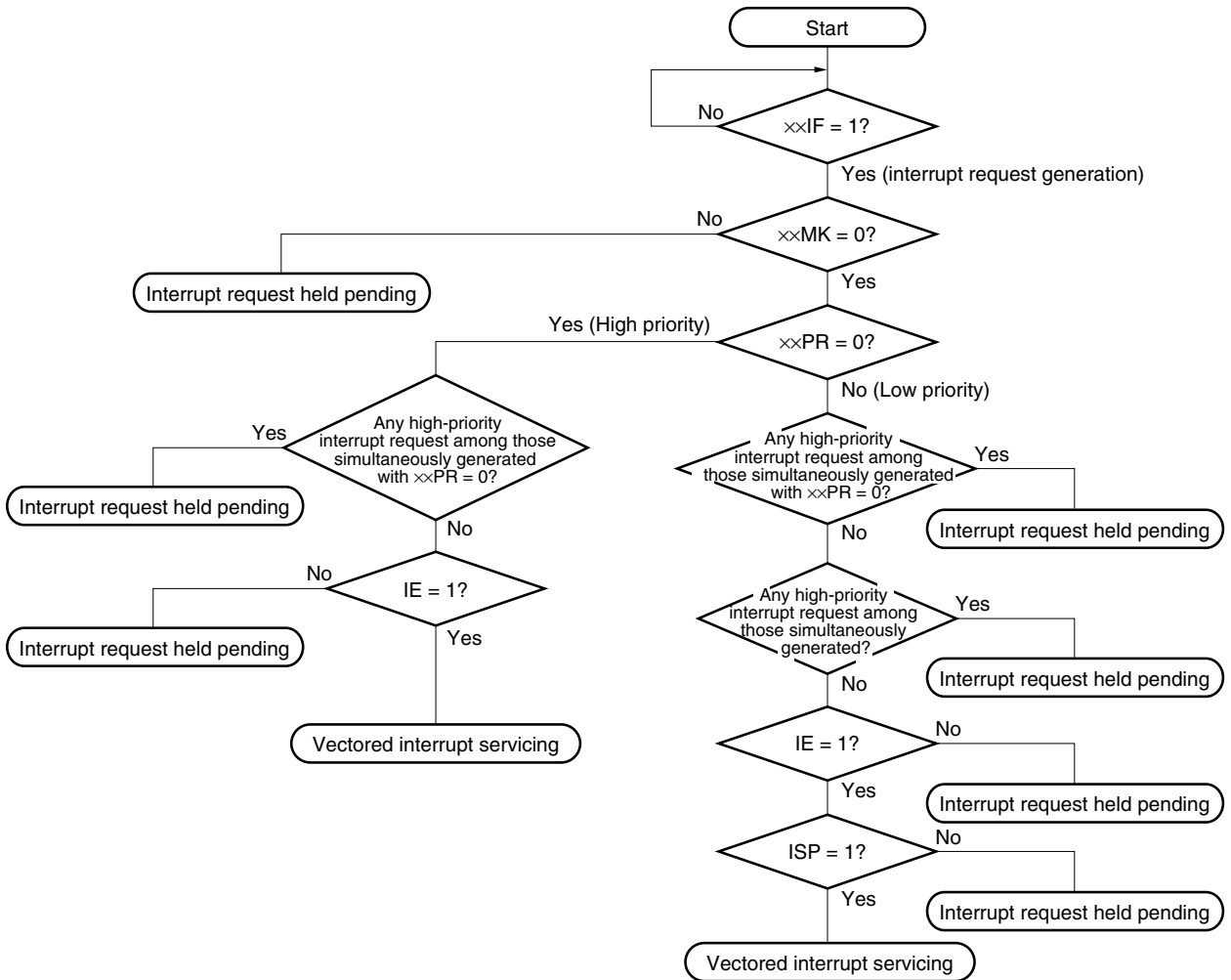

××IF: Interrupt request flag

××MK: Interrupt mask flag

××PR: Priority specification flag

IE: Flag that controls acknowledgement of maskable interrupt request (1 = Enable, 0 = Disable)

ISP: Flag that indicates the priority level of the interrupt currently being serviced (0 = high-priority interrupt servicing, 1 = No interrupt request acknowledged, or low-priority interrupt servicing)

Figure 15-8. Interrupt Request Acknowledgement Timing (Minimum Time)

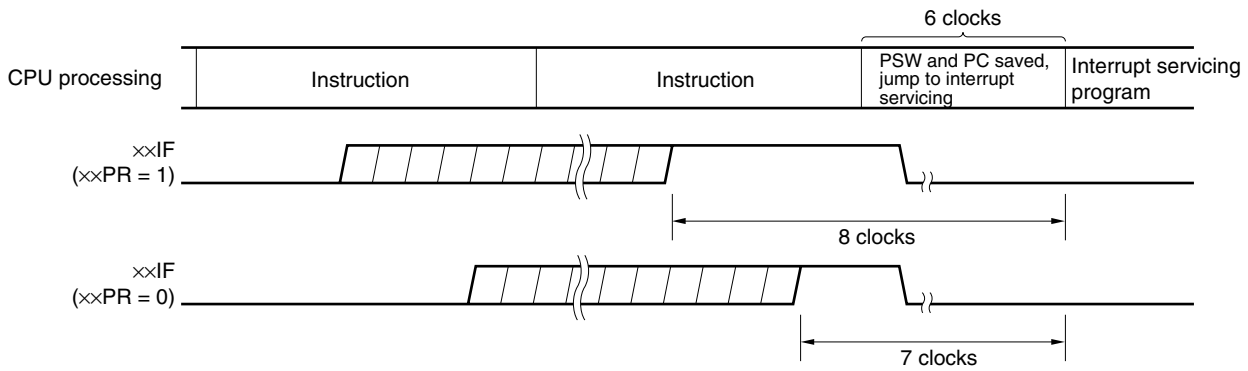

Remark 1 clock: $1/f_{CPU}$ (f_{CPU} : CPU clock)

Figure 15-9. Interrupt Request Acknowledgement Timing (Maximum Time)

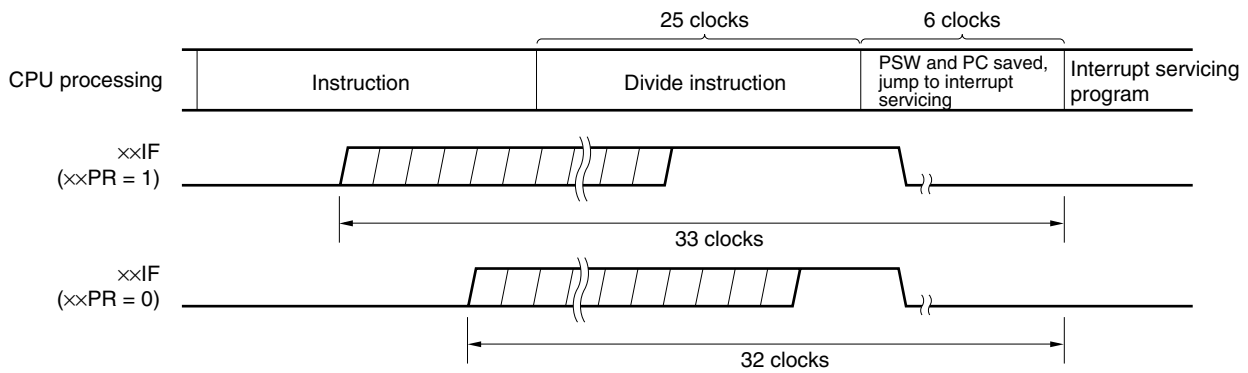

Remark 1 clock: $1/f_{CPU}$ (f_{CPU} : CPU clock)

15.4.2 Software interrupt request acknowledgement

A software interrupt acknowledge is acknowledged by BRK instruction execution. Software interrupts cannot be disabled.

If a software interrupt request is acknowledged, the contents are saved into the stacks in the order of the program status word (PSW), then program counter (PC), the IE flag is reset (0), and the contents of the vector table (003EH, 003FH) are loaded into the PC and branched.

Restoring from a software interrupt is possible by using the RETB instruction.

Caution Do not use the RETI instruction for restoring from the software interrupt.

15.4.3 Multiple interrupt servicing

Multiple interrupt servicing occurs when another interrupt request is acknowledged during execution of an interrupt.

Multiple interrupt servicing does not occur unless the interrupt request acknowledgement enabled state is selected (IE = 1). When an interrupt request is acknowledged, interrupt request acknowledgement becomes disabled (IE = 0). Therefore, to enable multiple interrupt servicing, it is necessary to set (1) the IE flag with the EI instruction during interrupt servicing to enable interrupt acknowledgement.

Moreover, even if interrupts are enabled, multiple interrupt servicing may not be enabled, this being subject to interrupt priority control. Two types of priority control are available: default priority control and programmable priority control. Programmable priority control is used for multiple interrupt servicing.

In the interrupt enabled state, if an interrupt request with a priority equal to or higher than that of the interrupt currently being serviced is generated, it is acknowledged for multiple interrupt servicing. If an interrupt with a priority lower than that of the interrupt currently being serviced is generated during interrupt servicing, it is not acknowledged for multiple interrupt servicing. Interrupt requests that are not enabled because interrupts are in the interrupt disabled state or because they have a lower priority are held pending. When servicing of the current interrupt ends, the pending interrupt request is acknowledged following execution of at least one main processing instruction execution.

Table 15-5 shows relationship between interrupt requests enabled for multiple interrupt servicing and Figure 15-10 shows multiple interrupt servicing examples.

Table 15-5. Relationship Between Interrupt Requests Enabled for Multiple Interrupt Servicing During Interrupt Servicing

Multiple Interrupt Request Interrupt Being Serviced		Maskable Interrupt Request				Software Interrupt Request
		PR = 0		PR = 1		
		IE = 1	IE = 0	IE = 1	IE = 0	
Maskable interrupt	ISP = 0	○	×	×	×	○
	ISP = 1	○	×	○	×	○
Software interrupt		○	×	○	×	○

- Remarks 1.** ○: Multiple interrupt servicing enabled
 2. ×: Multiple interrupt servicing disabled
 3. ISP and IE are flags contained in the PSW.
 ISP = 0: An interrupt with higher priority is being serviced.
 ISP = 1: No interrupt request has been acknowledged, or an interrupt with a lower priority is being serviced.
 IE = 0: Interrupt request acknowledgement is disabled.
 IE = 1: Interrupt request acknowledgement is enabled.
 4. PR is a flag contained in PR0L, PR0H, PR1L, and PR1H.
 PR = 0: Higher priority level
 PR = 1: Lower priority level

Figure 15-10. Examples of Multiple Interrupt Servicing (1/2)

Example 1. Multiple interrupt servicing occurs twice

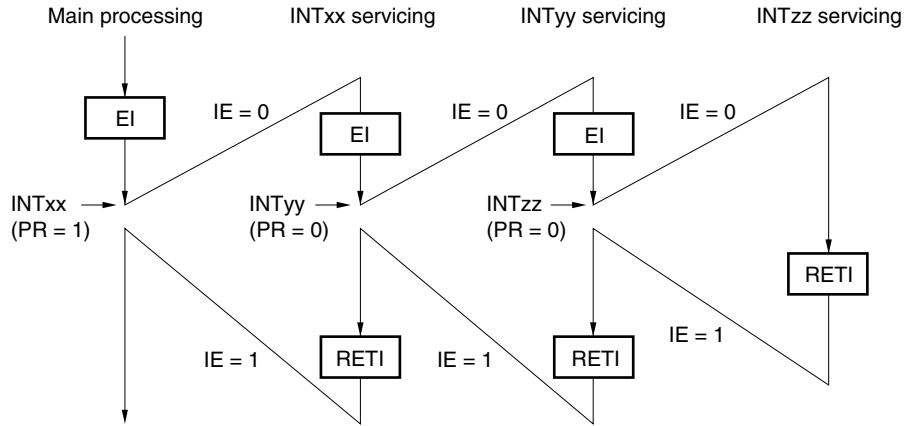

During servicing of interrupt INTxx, two interrupt requests, INTyy and INTzz, are acknowledged, and multiple interrupt servicing takes place. Before each interrupt request is acknowledged, the EI instruction must always be issued to enable interrupt request acknowledgment.

Example 2. Multiple interrupt servicing does not occur due to priority control

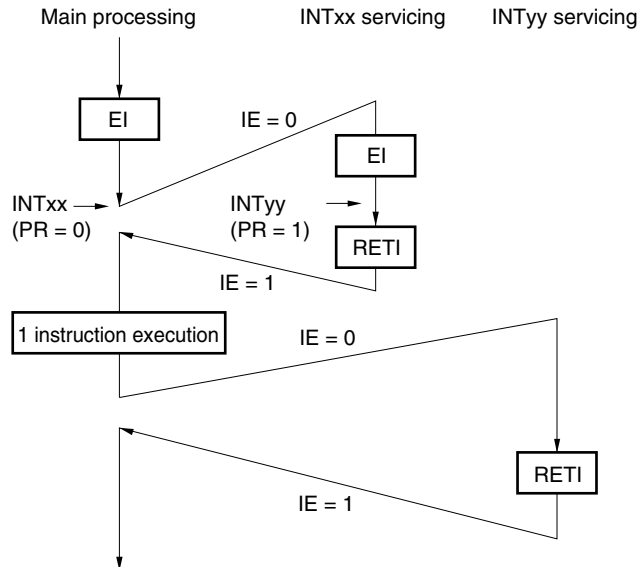

Interrupt request INTyy issued during servicing of interrupt INTxx is not acknowledged because its priority is lower than that of INTxx, and multiple interrupt servicing does not take place. The INTyy interrupt request is held pending, and is acknowledged following execution of one main processing instruction.

- PR = 0: Higher priority level
- PR = 1: Lower priority level
- IE = 0: Interrupt request acknowledgment disabled

Figure 15-10. Examples of Multiple Interrupt Servicing (2/2)

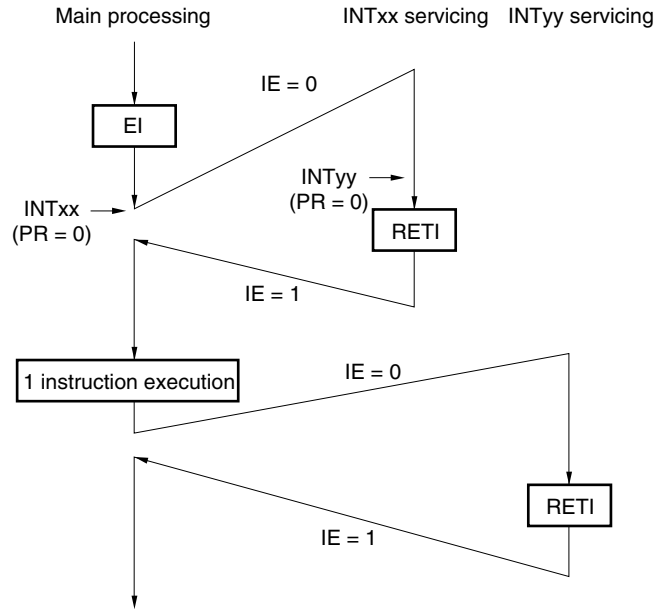
Example 3. Multiple interrupt servicing does not occur because interrupts are not enabled

Interrupts are not enabled during servicing of interrupt INTxx (EI instruction is not issued), therefore, interrupt request INTyy is not acknowledged and multiple interrupt servicing does not take place. The INTyy interrupt request is held pending, and is acknowledged following execution of one main processing instruction.

PR = 0: Higher priority level

IE = 0: Interrupt request acknowledgement disabled

15.4.4 Interrupt request hold

There are instructions where, even if an interrupt request is issued for them while another instruction is being executed, request acknowledgement is held pending until the end of execution of the next instruction. These instructions (interrupt request hold instructions) are listed below.

- MOV PSW, #byte
- MOV A, PSW
- MOV PSW, A
- MOV1 PSW. bit, CY
- MOV1 CY, PSW. bit
- AND1 CY, PSW. bit
- OR1 CY, PSW. bit
- XOR1 CY, PSW. bit
- SET1 PSW. bit
- CLR1 PSW. bit
- RETB
- RETI
- PUSH PSW
- POP PSW
- BT PSW. bit, \$addr16
- BF PSW. bit, \$addr16
- BTCLR PSW. bit, \$addr16
- EI
- DI
- Manipulation instructions for the IF0L, IF0H, IF1L, IF1H, MK0L, MK0H, MK1L, MK1H, PR0L, PR0H, PR1L, and PR1H registers.

Caution The BRK instruction is not one of the above-listed interrupt request hold instructions. However, the software interrupt activated by executing the BRK instruction causes the IE flag to be cleared. Therefore, even if a maskable interrupt request is generated during execution of the BRK instruction, the interrupt request is not acknowledged.

Figure 15-11 shows the timing at which interrupt requests are held pending.

Figure 15-11. Interrupt Request Hold

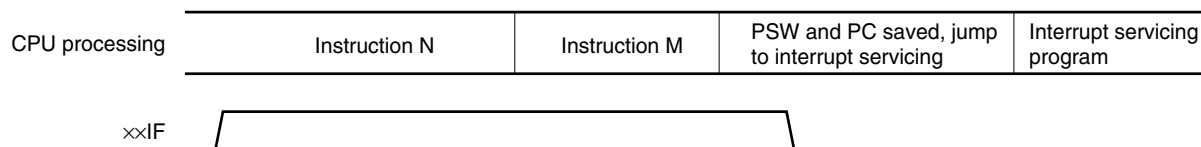

- Remarks**
1. Instruction N: Interrupt request hold instruction
 2. Instruction M: Instruction other than interrupt request hold instruction
 3. The $\times\times$ PR (priority level) values do not affect the operation of $\times\times$ IF (interrupt request).

CHAPTER 16 STANDBY FUNCTION

16.1 Standby Function and Configuration

16.1.1 Standby function

The standby function is designed to reduce the operating current of the system. The following two modes are available.

(1) HALT mode

HALT instruction execution sets the HALT mode. In the HALT mode, the CPU operation clock is stopped. If the high-speed system clock oscillator, internal high-speed oscillator, or internal low-speed oscillator is operating before the HALT mode is set, oscillation of each clock continues. In this mode, the operating current is not decreased as much as in the STOP mode, but the HALT mode is effective for restarting operation immediately upon interrupt request generation and carrying out intermittent operations frequently.

(2) STOP mode

STOP instruction execution sets the STOP mode. In the STOP mode, the high-speed system clock oscillator and internal high-speed oscillator stop, stopping the whole system, thereby considerably reducing the CPU operating current.

Because this mode can be cleared by an interrupt request, it enables intermittent operations to be carried out. However, because a wait time is required to secure the oscillation stabilization time after the STOP mode is released when the X1 clock is selected, select the HALT mode if it is necessary to start processing immediately upon interrupt request generation.

In either of these two modes, all the contents of registers, flags and data memory just before the standby mode is set are held. The I/O port output latches and output buffer statuses are also held.

- Cautions**
1. When shifting to the STOP mode, be sure to stop the peripheral hardware operation operating with main system clock before executing STOP instruction.
 2. The following sequence is recommended for operating current reduction of the A/D converter when the standby function is used: First clear bit 7 (ADCS) and bit 0 (ADCE) of the A/D converter mode register (ADM) to 0 to stop the A/D conversion operation, and then execute the STOP instruction.

16.1.2 Registers controlling standby function

The standby function is controlled by the following two registers.

- Oscillation stabilization time counter status register (OSTC)
- Oscillation stabilization time select register (OSTS)

Remark For the registers that start, stop, or select the clock, see **CHAPTER 5 CLOCK GENERATOR**.

(1) Oscillation stabilization time counter status register (OSTC)

This is the register that indicates the count status of the X1 clock oscillation stabilization time counter. When X1 clock oscillation starts with the internal high-speed oscillation clock used as the CPU clock, the X1 clock oscillation stabilization time can be checked.

OSTC can be read by a 1-bit or 8-bit memory manipulation instruction.

When reset is released (reset by $\overline{\text{RESET}}$ input, POC, LVI, and WDT), the STOP instruction and MSTOP (bit 7 of MOC register) = 1 clear OSTC to 00H.

Figure 16-1. Format of Oscillation Stabilization Time Counter Status Register (OSTC)

Address: FFA3H After reset: 00H R

Symbol	7	6	5	4	3	2	1	0
OSTC	0	0	0	MOST11	MOST13	MOST14	MOST15	MOST16

MOST11	MOST13	MOST14	MOST15	MOST16	Oscillation stabilization time status	
					$f_x = 10 \text{ MHz}$	$f_x = 20 \text{ MHz}$
1	0	0	0	0	$2^{11}/f_x \text{ min.}$	204.8 $\mu\text{s min.}$
1	1	0	0	0	$2^{13}/f_x \text{ min.}$	819.2 $\mu\text{s min.}$
1	1	1	0	0	$2^{14}/f_x \text{ min.}$	1.64 ms min.
1	1	1	1	0	$2^{15}/f_x \text{ min.}$	3.27 ms min.
1	1	1	1	1	$2^{16}/f_x \text{ min.}$	6.55 ms min.

- Cautions**
- After the above time has elapsed, the bits are set to 1 in order from MOST11 and remain 1.
 - The oscillation stabilization time counter counts up to the oscillation stabilization time set by OSTC. If the STOP mode is entered and then released while the internal high-speed oscillation clock is being used as the CPU clock, set the oscillation stabilization time as follows.
 - Desired OSTC oscillation stabilization time \leq Oscillation stabilization time set by OSTC

Note, therefore, that only the status up to the oscillation stabilization time set by OSTC is set to OSTC after STOP mode is released.
 - The X1 clock oscillation stabilization wait time does not include the time until clock oscillation starts (“a” below).

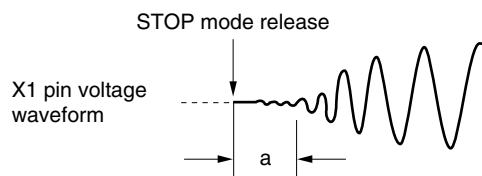

Remark f_x : X1 clock oscillation frequency

(2) Oscillation stabilization time select register (OSTS)

This register is used to select the X1 clock oscillation stabilization wait time when the STOP mode is released. When the X1 clock is selected as the CPU clock, the operation waits for the time set using OSTS after the STOP mode is released.

When the internal high-speed oscillation clock is selected as the CPU clock, confirm with OSTC that the desired oscillation stabilization time has elapsed after the STOP mode is released. The oscillation stabilization time can be checked up to the time set using OSTC.

OSTS can be set by an 8-bit memory manipulation instruction.

Reset signal generation sets OSTS to 05H.

Figure 16-2. Format of Oscillation Stabilization Time Select Register (OSTS)

Address: FFA4H After reset: 05H R/W

Symbol	7	6	5	4	3	2	1	0
OSTS	0	0	0	0	0	OSTS2	OSTS1	OSTS0

OSTS2	OSTS1	OSTS0	Oscillation stabilization time selection	Oscillation stabilization time selection	
				$f_x = 10 \text{ MHz}$	$f_x = 20 \text{ MHz}$
0	0	1	$2^{11}/f_x$	204.8 μs	102.4 μs
0	1	0	$2^{13}/f_x$	819.2 μs	409.6 μs
0	1	1	$2^{14}/f_x$	1.64 ms	819.2 μs
1	0	0	$2^{15}/f_x$	3.27 ms	1.64 ms
1	0	1	$2^{16}/f_x$	6.55 ms	3.27 ms
Other than above			Setting prohibited		

- Cautions**
- To set the STOP mode when the X1 clock is used as the CPU clock, set OSTS before executing the STOP instruction.**
 - Do not change the value of the OSTS register during the X1 clock oscillation stabilization time.**
 - The oscillation stabilization time counter counts up to the oscillation stabilization time set by OSTS. If the STOP mode is entered and then released while the internal high-speed oscillation clock is being used as the CPU clock, set the oscillation stabilization time as follows.**
 - Desired OSTC oscillation stabilization time \leq Oscillation stabilization time set by OSTS**

Note, therefore, that only the status up to the oscillation stabilization time set by OSTS is set to OSTC after STOP mode is released.
 - The X1 clock oscillation stabilization wait time does not include the time until clock oscillation starts (“a” below).**

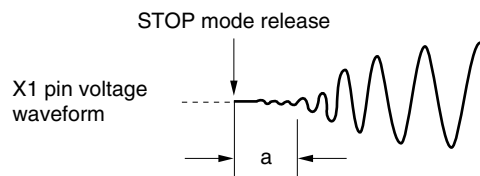

Remark f_x : X1 clock oscillation frequency

16.2 Standby Function Operation

16.2.1 HALT mode

(1) HALT mode

The HALT mode is set by executing the HALT instruction. HALT mode can be set regardless of whether the CPU clock before the setting was the high-speed system clock, or internal high-speed oscillation clock.

The operating statuses in the HALT mode are shown below.

Table 16-1. Operating Statuses in HALT Mode

HALT Mode Setting Item		When HALT Instruction Is Executed While CPU Is Operating on Main System Clock		
		When CPU Is Operating on Internal High-Speed Oscillation Clock (f _{RH})	When CPU Is Operating on X1 Clock (f _x)	When CPU Is Operating on External Main System Clock (f _{EXCLK})
System clock		Clock supply to the CPU is stopped		
Main system clock	f _{RH}	Operation continues (cannot be stopped)	Status before HALT mode was set is retained	
	f _x	Status before HALT mode was set is retained	Operation continues (cannot be stopped)	Status before HALT mode was set is retained
	f _{EXCLK}	Operates or stops by external clock input		Operation continues (cannot be stopped)
f _{RL}		Status before HALT mode was set is retained		
CPU		Operation stopped		
Flash memory		Operation stopped		
RAM		Status before HALT mode was set is retained		
Port (latch)		Status before HALT mode was set is retained		
16-bit timer/event counter 00		Operable		
8-bit timer/event counter	50			
	51			
8-bit timer	H0			
	H1			
Watchdog timer		Operable. Clock supply to watchdog timer stops when “internal low-speed oscillator can be stopped by software” is set by option byte.		
A/D converter		Operable		
Serial interface	UART0			
	UART6			
	CSI10			
	IIC0			
Power-on-clear function				
Low-voltage detection function				
External interrupt				

Remark f_{RH}: Internal high-speed oscillation clock
f_x: X1 clock
f_{EXCLK}: External main system clock
f_{RL}: Internal low-speed oscillation clock

(2) HALT mode release

The HALT mode can be released by the following two sources.

(a) Release by unmasked interrupt request

When an unmasked interrupt request is generated, the HALT mode is released. If interrupt acknowledgement is enabled, vectored interrupt servicing is carried out. If interrupt acknowledgement is disabled, the next address instruction is executed.

Figure 16-3. HALT Mode Release by Interrupt Request Generation

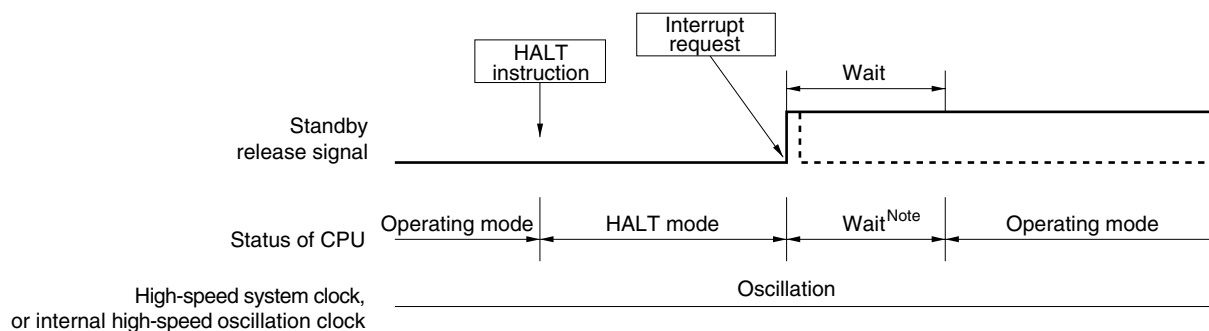

Note The wait time is as follows:

- When vectored interrupt servicing is carried out: 8 or 9 clocks
- When vectored interrupt servicing is not carried out: 2 or 3 clocks

Remark The broken lines indicate the case when the interrupt request which has released the standby mode is acknowledged.

(b) Release by reset signal generation

When the reset signal is generated, HALT mode is released, and then, as in the case with a normal reset operation, the program is executed after branching to the reset vector address.

<R>

Figure 16-4. HALT Mode Release by Reset

(1) When high-speed system clock is used as CPU clock

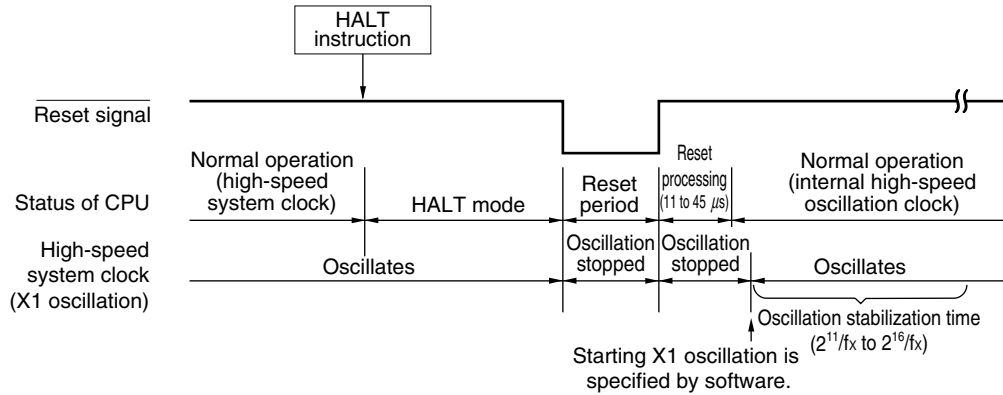

(2) When internal high-speed oscillation clock is used as CPU clock

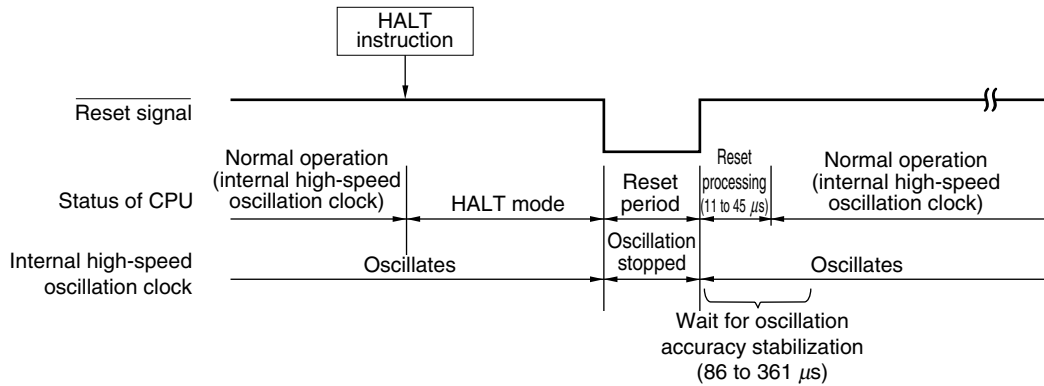

Remark fx: X1 clock oscillation frequency

Table 16-2. Operation in Response to Interrupt Request in HALT Mode

Release Source	MK _{xx}	PR _{xx}	IE	ISP	Operation
Maskable interrupt request	0	0	0	×	Next address instruction execution
	0	0	1	×	Interrupt servicing execution
	0	1	0	1	Next address instruction execution
	0	1	×	0	
	0	1	1	1	Interrupt servicing execution
	1	×	×	×	HALT mode held
Reset	–	–	×	×	Reset processing

×: don't care

16.2.2 STOP mode

(1) STOP mode setting and operating statuses

The STOP mode is set by executing the STOP instruction. STOP mode can be set regardless of whether the CPU clock before the setting was the high-speed system clock, or internal high-speed oscillation clock.

Caution Because the interrupt request signal is used to clear the standby mode, if there is an interrupt source with the interrupt request flag set and the interrupt mask flag reset, the standby mode is immediately cleared if set. Thus, the STOP mode is reset to the HALT mode immediately after execution of the STOP instruction and the system returns to the operating mode as soon as the wait time set using the oscillation stabilization time select register (OSTS) has elapsed.

The operating statuses in the STOP mode are shown below.

Table 16-3. Operating Statuses in STOP Mode

STOP Mode Setting		When STOP Instruction Is Executed While CPU Is Operating on Main System Clock		
		When CPU Is Operating on Internal High-Speed Oscillation Clock (f_{RH})	When CPU Is Operating on X1 Clock (f_x)	When CPU Is Operating on External Main System Clock (f_{EXCLK})
Item				
System clock		Clock supply to the CPU is stopped		
Main system clock	f_{RH}	Stopped		
	f_x	Stopped		
	f_{EXCLK}	Input invalid		
	f_{RL}	Status before STOP mode was set is retained		
CPU		Operation stopped		
Flash memory		Operation stopped		
RAM		Status before STOP mode was set is retained		
Port (latch)		Status before STOP mode was set is retained		
16-bit timer/event counter 00 ^{Note}		Operation stopped		
8-bit timer/event counter	50 ^{Note}	Operable only when TI50 is selected as the count clock		
	51 ^{Note}	Operable only when TI51 is selected as the count clock		
8-bit timer	H0	Operable only when TM50 output is selected as the count clock during 8-bit timer/event counter 50 operation		
	H1	Operable only when f_{RL} , $f_{RL}/2^7$, $f_{RL}/2^3$ is selected as the count clock		
Watchdog timer		Operable. Clock supply to watchdog timer stops when "internal low-speed oscillator can be stopped by software" is set by option byte.		
A/D converter				
Serial interface	UART0	Operable only when TM50 output is selected as the serial clock during 8-bit timer/event counter 50 operation		
	UART6			
	CSI10 ^{Note}	Operable only when external clock is selected as the serial clock		
	IIC0 ^{Note}	Operation stopped		
Power-on-clear function		Operable		
Low-voltage detection function				
External interrupt				

<R>

<R>

Note Do not start operation of these functions on the external clock input from peripheral hardware pins in the stop mode.

Remark f_{RH} : Internal high-speed oscillation clock
 f_x : X1 clock
 f_{EXCLK} : External main system clock
 f_{RL} : Internal low-speed oscillation clock

- Cautions**
1. To use the peripheral hardware that stops operation in the STOP mode, and the peripheral hardware for which the clock that stops oscillating in the STOP mode after the STOP mode is released, restart the peripheral hardware.
 2. Even if “internal low-speed oscillator can be stopped by software” is selected by the option byte, the internal low-speed oscillation clock continues in the STOP mode in the status before the STOP mode is set. To stop the internal low-speed oscillator’s oscillation in the STOP mode, stop it by software and then execute the STOP instruction.
 3. To shorten oscillation stabilization time after the STOP mode is released when the CPU operates with the high-speed system clock (X1 oscillation), temporarily switch the CPU clock to the internal high-speed oscillation clock before the next execution of the STOP instruction. Before changing the CPU clock from the internal high-speed oscillation clock to the high-speed system clock (X1 oscillation) after the STOP mode is released, check the oscillation stabilization time with the oscillation stabilization time counter status register (OSTC).
- <R>
4. If the STOP instruction is executed when AMPH = 1, supply of the CPU clock is stopped for 4.06 to 16.12 μs after the STOP mode is released when the internal high-speed oscillation clock is selected as the CPU clock, or for the duration of 160 external clocks when the high-speed system clock (external clock input) is selected as the CPU clock.

(2) STOP mode release

<R>

Figure 16-5. Operation Timing When STOP Mode Is Released

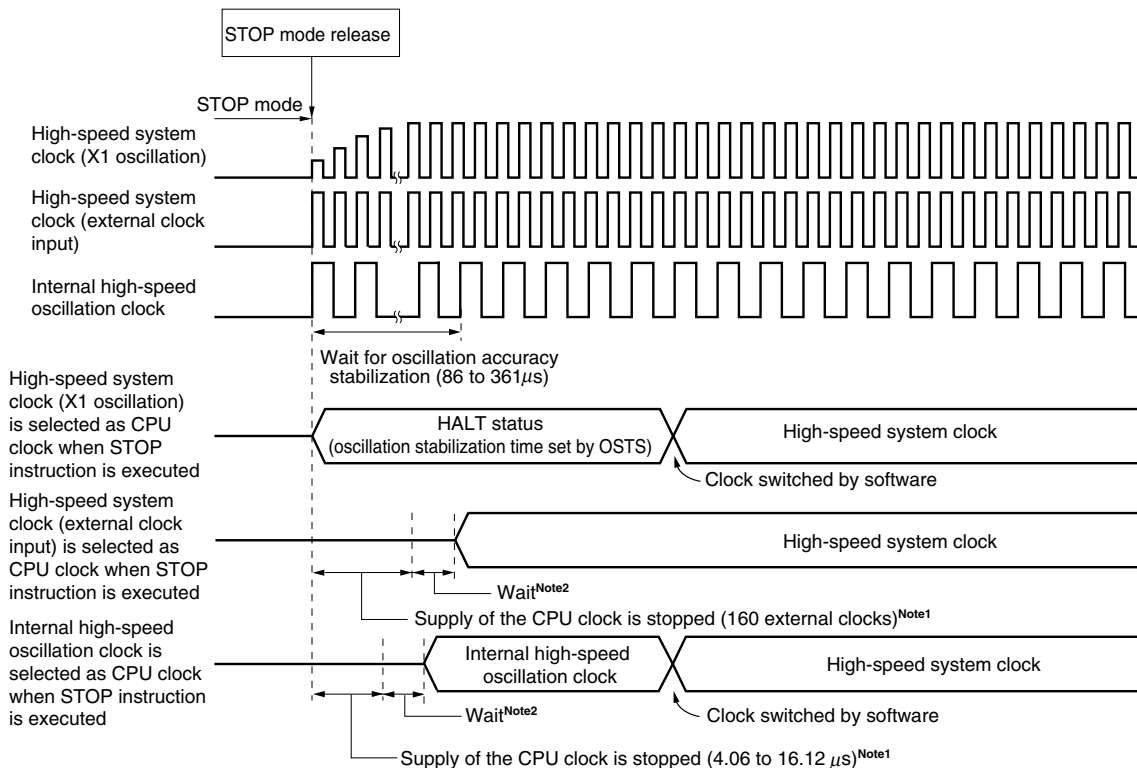

Notes 1. When AMPH = 1

2. The wait time is as follows:

- When vectored interrupt servicing is carried out: 8 or 9 clocks
- When vectored interrupt servicing is not carried out: 2 or 3 clocks

The STOP mode can be released by the following two sources.

(a) Release by unmasked interrupt request

When an unmasked interrupt request is generated, the STOP mode is released. After the oscillation stabilization time has elapsed, if interrupt acknowledgment is enabled, vectored interrupt servicing is carried out. If interrupt acknowledgment is disabled, the next address instruction is executed.

<R>

Figure 16-6. STOP Mode Release by Interrupt Request Generation

(1) When high-speed system clock (X1 oscillation) is used as CPU clock

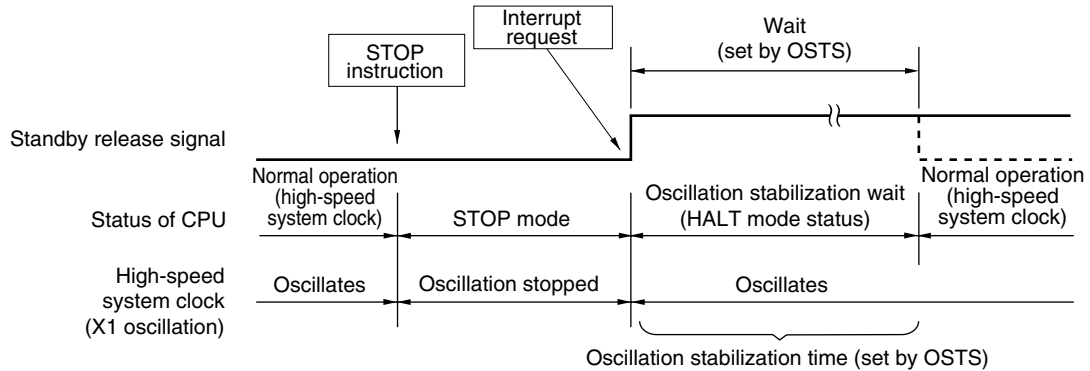

(2) When high-speed system clock (external clock input) is used as CPU clock (1/2)

- When AMPH = 1

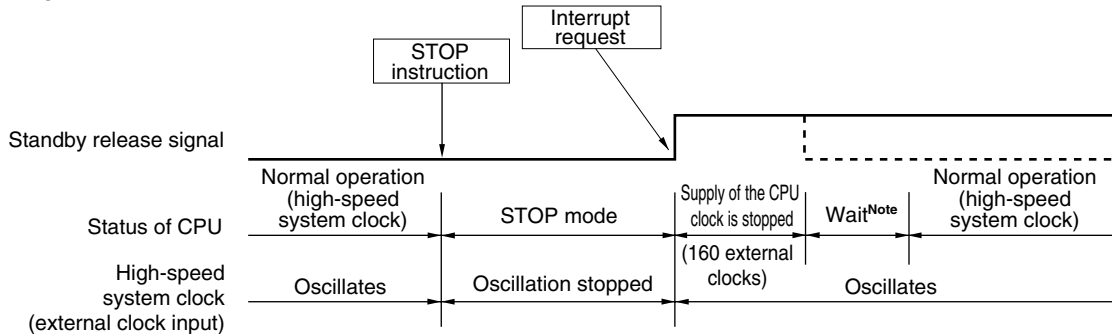

Note The wait time is as follows:

- When vectored interrupt servicing is carried out: 8 or 9 clocks
- When vectored interrupt servicing is not carried out: 2 or 3 clocks

Remark The broken lines indicate the case when the interrupt request that has released the standby mode is acknowledged.

<R>

Figure 16-6. STOP Mode Release by Interrupt Request Generation (2/2)

(2) When high-speed system clock (external clock input) is used as CPU clock (2/2)

- When AMPH = 0

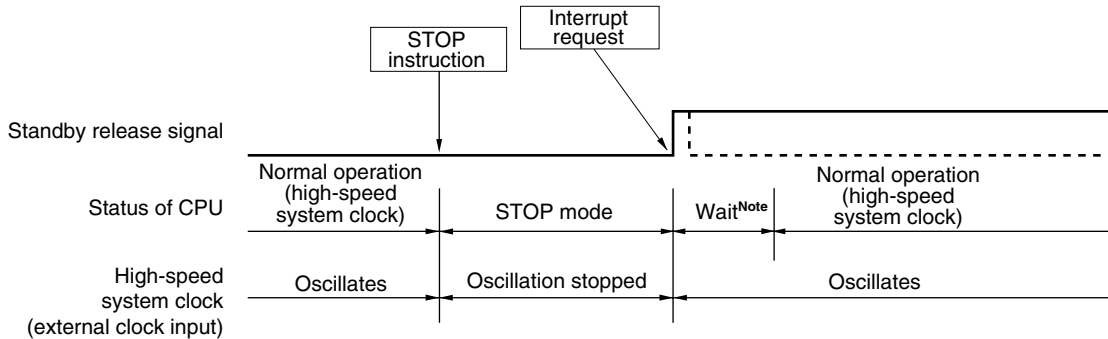

(3) When internal high-speed oscillation clock is used as CPU clock

- When AMPH = 1

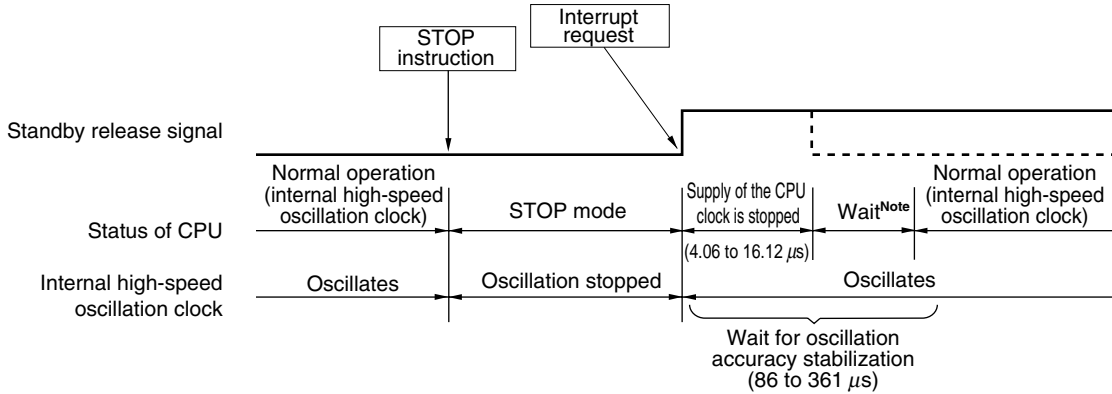

- When AMPH = 0

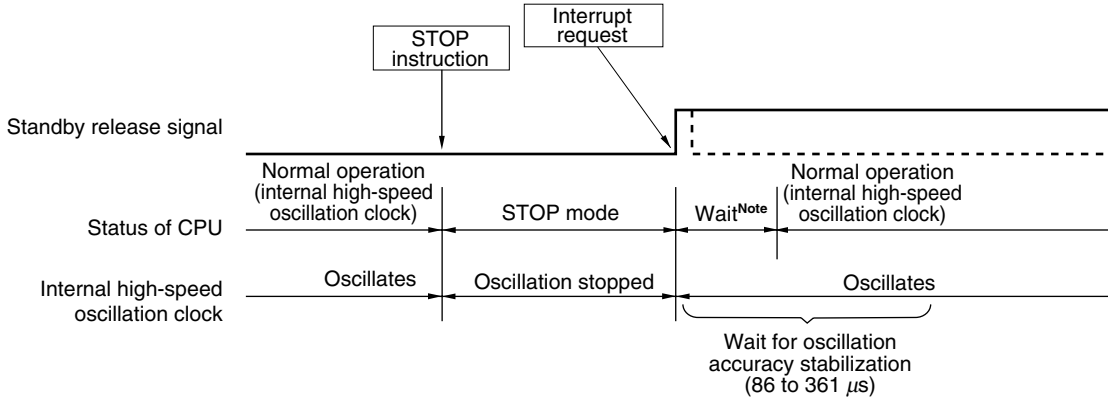

Note The wait time is as follows:

- When vectored interrupt servicing is carried out: 8 or 9 clocks
- When vectored interrupt servicing is not carried out: 2 or 3 clocks

Remark The broken lines indicate the case when the interrupt request that has released the standby mode is acknowledged.

(b) Release by reset signal generation

When the reset signal is generated, STOP mode is released, and then, as in the case with a normal reset operation, the program is executed after branching to the reset vector address.

<R>

Figure 16-7. STOP Mode Release by Reset

(1) When high-speed system clock is used as CPU clock

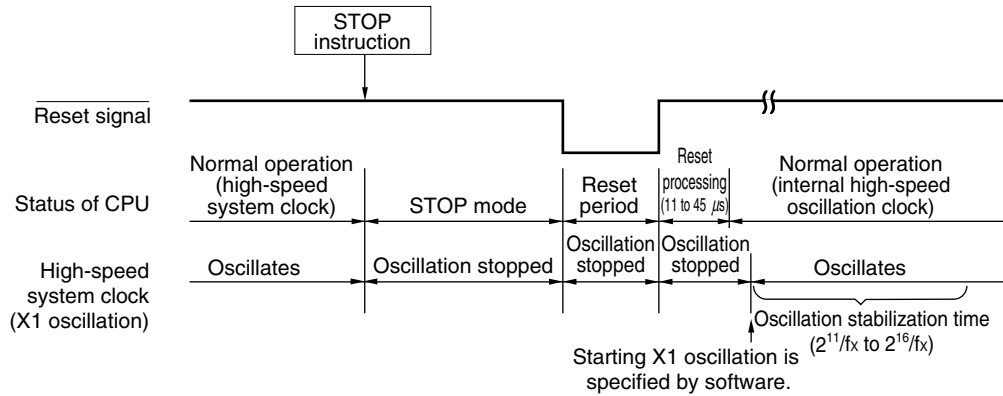

(2) When internal high-speed oscillation clock is used as CPU clock

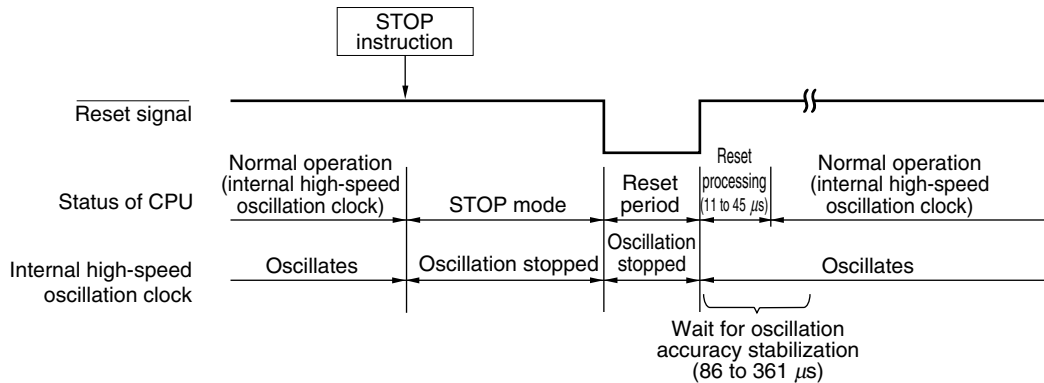

Remark fx: X1 clock oscillation frequency

Table 16-4. Operation in Response to Interrupt Request in STOP Mode

Release Source	MKxx	PRxx	IE	ISP	Operation
Maskable interrupt request	0	0	0	×	Next address instruction execution
	0	0	1	×	Interrupt servicing execution
	0	1	0	1	Next address instruction execution
	0	1	×	0	
	0	1	1	1	Interrupt servicing execution
	1	×	×	×	STOP mode held
Reset	–	–	×	×	Reset processing

×: don't care

CHAPTER 17 RESET FUNCTION

The following four operations are available to generate a reset signal.

- (1) External reset input via $\overline{\text{RESET}}$ pin
- (2) Internal reset by watchdog timer program loop detection
- (3) Internal reset by comparison of supply voltage and detection voltage of power-on-clear (POC) circuit
- (4) Internal reset by comparison of supply voltage and detection voltage of low-power-supply detector (LVI)

External and internal resets have no functional differences. In both cases, program execution starts at the address at 0000H and 0001H when the reset signal is generated.

A reset is applied when a low level is input to the $\overline{\text{RESET}}$ pin, the watchdog timer overflows, or by POC and LVI circuit voltage detection, and each item of hardware is set to the status shown in Tables 17-1 and 17-2. Each pin is high impedance during reset signal generation or during the oscillation stabilization time just after a reset release.

When a low level is input to the $\overline{\text{RESET}}$ pin, the device is reset. It is released from the reset status when a high level is input to the $\overline{\text{RESET}}$ pin and program execution is started with the internal high-speed oscillation clock after reset processing. A reset by the watchdog timer is automatically released, and program execution starts using the internal high-speed oscillation clock (see **Figures 17-2 to 17-4**) after reset processing. Reset by POC and LVI circuit power supply detection is automatically released when $V_{DD} \geq V_{POC}$ or $V_{DD} \geq V_{LVI}$ after the reset, and program execution starts using the internal high-speed oscillation clock (see **CHAPTER 18 POWER-ON-CLEAR CIRCUIT** and **CHAPTER 19 LOW-VOLTAGE DETECTOR**) after reset processing.

- Cautions**
- 1. For an external reset, input a low level for 10 μs or more to the $\overline{\text{RESET}}$ pin.**
 - 2. During reset input, the X1 clock, internal high-speed oscillation clock, and internal low-speed oscillation clock stop oscillating. External main system clock input becomes invalid.**
 - 3. When the STOP mode is released by a reset, the STOP mode contents are held during reset input. However, the port pins become high-impedance.**

Figure 17-1. Block Diagram of Reset Function

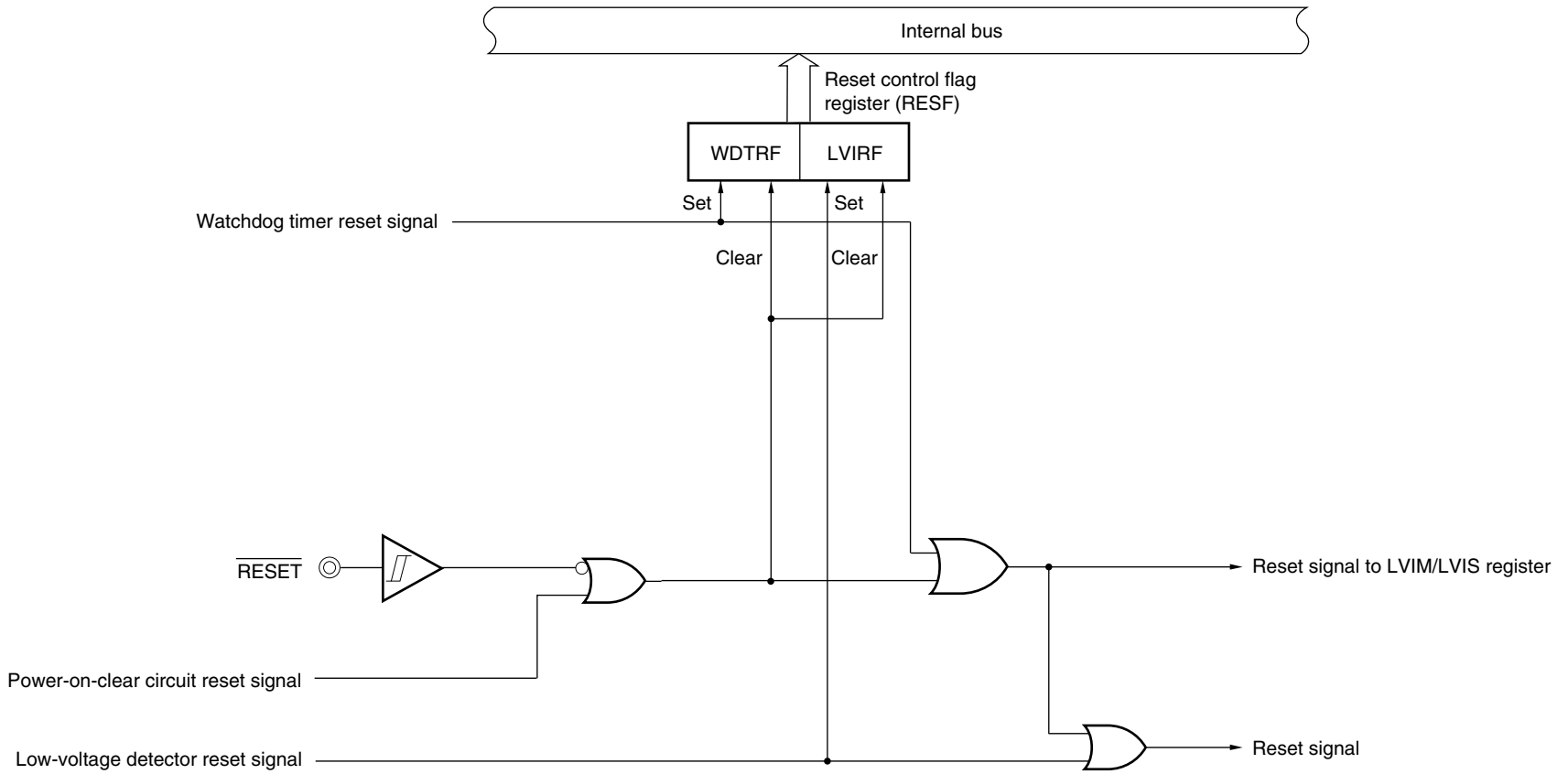

Caution An LVI circuit internal reset does not reset the LVI circuit.

- Remarks**
1. LVIM: Low-voltage detection register
 2. LVIS: Low-voltage detection level selection register

<R>

Figure 17-2. Timing of Reset by RESET Input

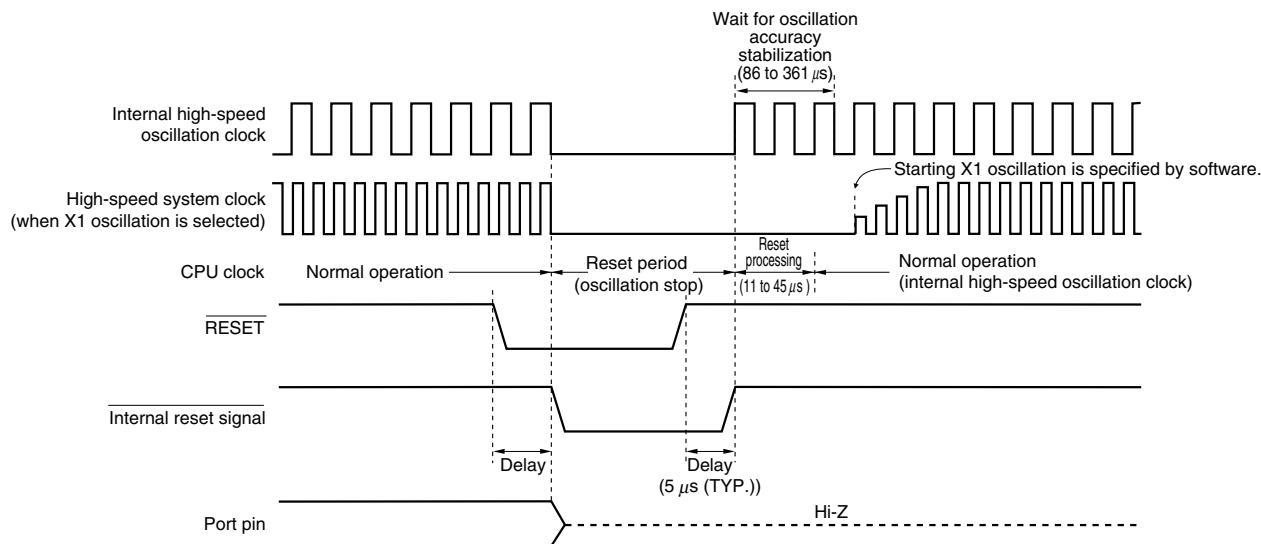

<R>

Figure 17-3. Timing of Reset Due to Watchdog Timer Overflow

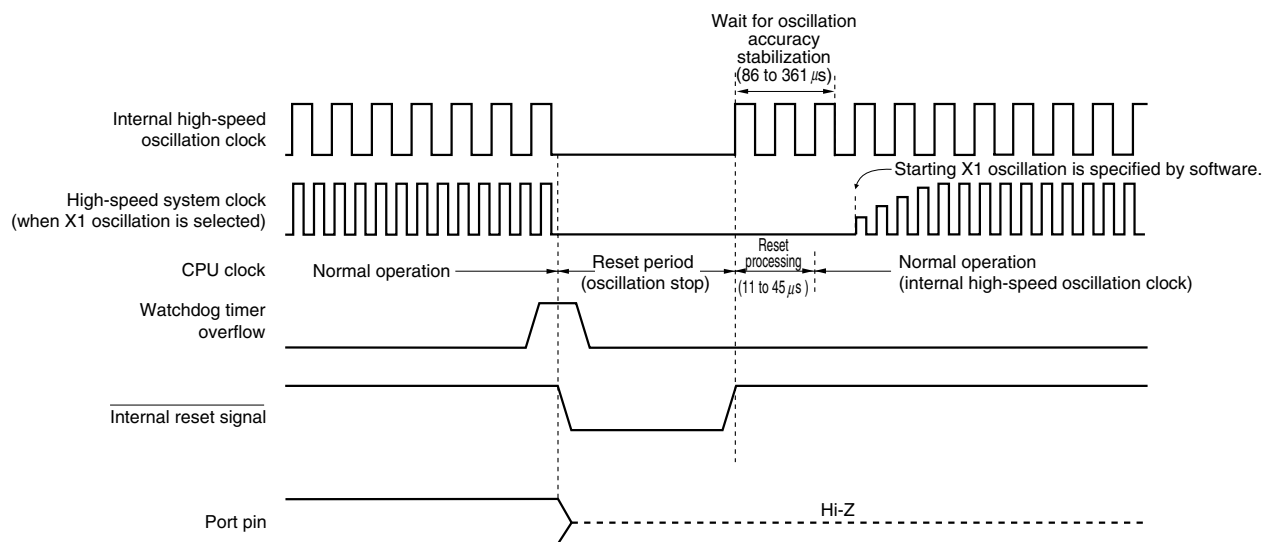

Caution A watchdog timer internal reset resets the watchdog timer.

<R>

Figure 17-4. Timing of Reset in STOP Mode by $\overline{\text{RESET}}$ Input

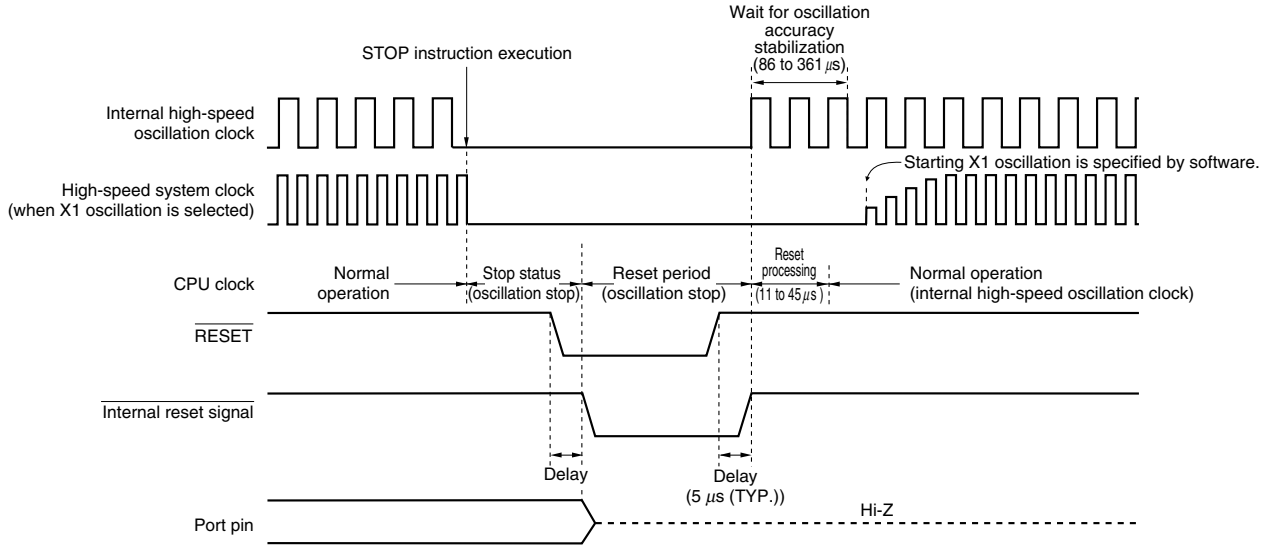

Remark For the reset timing of the power-on-clear circuit and low-voltage detector, see **CHAPTER 18 POWER-ON-CLEAR CIRCUIT** and **CHAPTER 19 LOW-VOLTAGE DETECTOR**.

Table 17-1. Operation Statuses During Reset Period

Item	During Reset Period		
System clock	Clock supply to the CPU is stopped.		
Main system clock	f_{RH}	Operation stopped	
	f_x	Operation stopped (pin is I/O port mode)	
	f_{EXCLK}	Clock input invalid (pin is I/O port mode)	
f_{RL}	Operation stopped		
CPU			
Flash memory			
RAM			
Port (latch)			
16-bit timer/event counter 00			
8-bit timer/event counter			50
			51
8-bit timer			H0
			H1
Watchdog timer			
A/D converter			
Serial interface			UART0
			UART6
			CSI10
			IIC0
Power-on-clear function	Operable		
Low-voltage detection function	Operation stopped		
External interrupt			

Remark

- f_{RH} : Internal high-speed oscillation clock
- f_x : X1 oscillation clock
- f_{EXCLK} : External main system clock
- f_{RL} : Internal low-speed oscillation clock

Table 17-2. Hardware Statuses After Reset Acknowledgment (1/3)

Hardware		After Reset Acknowledgment ^{Note 1}
Program counter (PC)		The contents of the reset vector table (0000H, 0001H) are set.
Stack pointer (SP)		Undefined
Program status word (PSW)		02H
RAM	Data memory	Undefined ^{Note 2}
	General-purpose registers	Undefined ^{Note 2}
Port registers (P0 to P3, P6 to P12) (output latches)		00H
Port mode registers (PM0 to PM3, PM6, PM12)		FFH
Pull-up resistor option registers (PU0, PU1, PU3, PU12)		00H
Internal memory size switching register (IMS)		CFH ^{Note 3}
Clock operation mode select register (OSCCTL)		00H
Processor clock control register (PCC)		01H
Internal oscillation mode register (RCM)		80H
Main OSC control register (MOC)		80H
Main clock mode register (MCM)		00H
Oscillation stabilization time counter status register (OSTC)		00H
Oscillation stabilization time select register (OSTS)		05H
16-bit timer/event counter 00	Timer counter 00 (TM00)	0000H
	Capture/compare registers 000, 010 (CR000, CR010)	0000H
	Mode control register 00 (TMC00)	00H
	Prescaler mode register 00 (PRM00)	00H
	Capture/compare control register 00 (CRC00)	00H
	Timer output control register 00 (TOC00)	00H
8-bit timer/event counters 50, 51	Timer counters 50, 51 (TM50, TM51)	00H
	Compare registers 50, 51 (CR50, CR51)	00H
	Timer clock selection registers 50, 51 (TCL50, TCL51)	00H
	Mode control registers 50, 51 (TMC50, TMC51)	00H

- Notes**
1. During reset signal generation or oscillation stabilization time wait, only the PC contents among the hardware statuses become undefined. All other hardware statuses remain unchanged after reset.
 2. When a reset is executed in the standby mode, the pre-reset status is held even after reset.
 3. The initial values of the internal memory size switching register (IMS) after a reset release are constant (IMS = CFH) in all the 78K0/KB2 products, regardless of the internal memory capacity. Therefore, after a reset is released, be sure to set the following values for each product.

Flash Memory Version (78K0/KB2)	IMS
μPD78F0500	42H
μPD78F0501	04H
μPD78F0502	C6H
μPD78F0503, 78F0503D	C8H

Table 17-2. Hardware Statuses After Reset Acknowledgment (2/3)

Hardware		Status After Reset Acknowledgment ^{Note 1}
8-bit timers H0, H1	Compare registers 00, 10, 01, 11 (CMP00, CMP10, CMP01, CMP11)	00H
	Mode registers (TMHMD0, TMHMD1)	00H
	Carrier control register 1 (TMCYC1) ^{Note 2}	00H
Watchdog timer	Enable register (WDTE)	1AH/9AH ^{Note 3}
A/D converter	10-bit A/D conversion result register (ADCR)	0000H
	8-bit A/D conversion result register (ADCRH)	00H
	Mode register (ADM)	00H
	Analog input channel specification register (ADS)	00H
	A/D port configuration register (ADPC)	00H
Serial interface UART0	Receive buffer register 0 (RXB0)	FFH
	Transmit shift register 0 (TXS0)	FFH
	Asynchronous serial interface operation mode register 0 (ASIM0)	01H
	Asynchronous serial interface reception error status register 0 (ASIS0)	00H
	Baud rate generator control register 0 (BRGC0)	1FH
Serial interface UART6	Receive buffer register 6 (RXB6)	FFH
	Transmit buffer register 6 (TXB6)	FFH
	Asynchronous serial interface operation mode register 6 (ASIM6)	01H
	Asynchronous serial interface reception error status register 6 (ASIS6)	00H
	Asynchronous serial interface transmission status register 6 (ASIF6)	00H
	Clock selection register 6 (CKSR6)	00H
	Baud rate generator control register 6 (BRGC6)	FFH
	Asynchronous serial interface control register 6 (ASICL6)	16H
	Input switch control register (ISC)	00H
Serial interface CSI10	Transmit buffer register 10 (SOTB10)	00H
	Serial I/O shift register 10 (SIO10)	00H
	Serial operation mode register 10 (CSIM10)	00H
	Serial clock selection register 10 (CSIC10)	00H

Notes 1. During reset signal generation or oscillation stabilization time wait, only the PC contents among the hardware statuses become undefined. All other hardware statuses remain unchanged after reset.

2. 8-bit timer H1 only.

3. The reset value of WDTE is determined by the option byte setting.

Table 17-2. Hardware Statuses After Reset Acknowledgment (3/3)

Hardware		Status After Reset Acknowledgment ^{Note 1}
Serial interface IIC0	Shift register 0 (IIC0)	00H
	Control register 0 (IICC0)	00H
	Slave address register 0 (SVA0)	00H
	Clock selection register 0 (IICCL0)	00H
	Function expansion register 0 (IICX0)	00H
	Status register 0 (IICS0)	00H
	Flag register 0 (IICF0)	00H
Reset function	Reset control flag register (RESF)	00H ^{Note 2}
Low-voltage detector	Low-voltage detection register (LVIM)	00H ^{Note 2}
	Low-voltage detection level selection register (LVIS)	00H ^{Note 2}
Interrupt	Request flag registers 0L, 0H, 1L, 1H (IF0L, IF0H, IF1L, IF1H)	00H
	Mask flag registers 0L, 0H, 1L, 1H (MK0L, MK0H, MK1L, MK1H)	FFH
	Priority specification flag registers 0L, 0H, 1L, 1H (PR0L, PR0H, PR1L, PR1H)	FFH
	External interrupt rising edge enable register (EGP)	00H
	External interrupt falling edge enable register (EGN)	00H

- Notes**
1. During reset signal generation or oscillation stabilization time wait, only the PC contents among the hardware statuses become undefined. All other hardware statuses remain unchanged after reset.
 2. These values vary depending on the reset source.

Reset Source		$\overline{\text{RESET}}$ Input	Reset by POC	Reset by WDT	Reset by LVI
Register	RESF	Cleared (0)	Cleared (0)	Set (1)	Held
	WDTRF bit			Held	Set (1)
	LVIRF bit				
	LVIM	Cleared (00H)	Cleared (00H)	Cleared (00H)	Held
	LVIS				

17.1 Register for Confirming Reset Source

Many internal reset generation sources exist in the 78K0/KB2. The reset control flag register (RESF) is used to store which source has generated the reset request.

RESF can be read by an 8-bit memory manipulation instruction.

$\overline{\text{RESET}}$ input, reset by power-on-clear (POC) circuit, and reading RESF set RESF to 00H.

Figure 17-5. Format of Reset Control Flag Register (RESF)

Address: FFACH After reset: 00H^{Note} R

Symbol	7	6	5	4	3	2	1	0
RESF	0	0	0	WDTRF	0	0	0	LVIRF

WDTRF	Internal reset request by watchdog timer (WDT)
0	Internal reset request is not generated, or RESF is cleared.
1	Internal reset request is generated.

LVIRF	Internal reset request by low-voltage detector (LVI)
0	Internal reset request is not generated, or RESF is cleared.
1	Internal reset request is generated.

Note The value after reset varies depending on the reset source.

Caution Do not read data by a 1-bit memory manipulation instruction.

The status of RESF when a reset request is generated is shown in Table 17-3.

Table 17-3. RESF Status When Reset Request Is Generated

Reset Source	$\overline{\text{RESET}}$ Input	Reset by POC	Reset by WDT	Reset by LVI
Flag				
WDTRF	Cleared (0)	Cleared (0)	Set (1)	Held
LVIRF			Held	Set (1)

CHAPTER 18 POWER-ON-CLEAR CIRCUIT

18.1 Functions of Power-on-Clear Circuit

The power-on-clear circuit (POC) has the following functions.

- Generates internal reset signal at power on.

In the 1.59 V POC mode (option byte: POCMODE = 0), the reset signal is released when the supply voltage (V_{DD}) exceeds $1.59\text{ V} \pm 0.15\text{ V}$.

In the 2.7 V/1.59 V POC mode (option byte: POCMODE = 1), the reset signal is released when the supply voltage (V_{DD}) exceeds $2.7\text{ V} \pm 0.2\text{ V}$.

<R>

- Compares supply voltage (V_{DD}) and detection voltage ($V_{POC} = 1.59\text{ V} \pm 0.15\text{ V}$), generates internal reset signal when $V_{DD} < V_{POC}$.

Caution If an internal reset signal is generated in the POC circuit, the reset control flag register (RESF) is cleared to 00H.

Remark This product incorporates multiple hardware functions that generate an internal reset signal. A flag that indicates the reset source is located in the reset control flag register (RESF) for when an internal reset signal is generated by the watchdog timer (WDT) or low-voltage-detector (LVI). RESF is not cleared to 00H and the flag is set to 1 when an internal reset signal is generated by WDT or LVI. For details of RESF, see **CHAPTER 17 RESET FUNCTION**.

18.2 Configuration of Power-on-Clear Circuit

The block diagram of the power-on-clear circuit is shown in Figure 18-1.

Figure 18-1. Block Diagram of Power-on-Clear Circuit

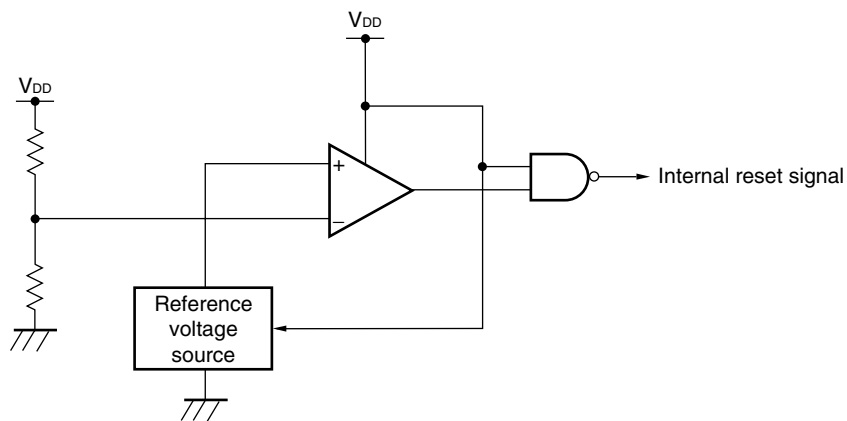

18.3 Operation of Power-on-Clear Circuit

(1) In 1.59 V POC mode (option byte: POCMODE = 0)

- An internal reset signal is generated on power application. When the supply voltage (V_{DD}) exceeds the detection voltage ($V_{POC} = 1.59\text{ V} \pm 0.15\text{ V}$), the reset status is released.
- The supply voltage (V_{DD}) and detection voltage ($V_{POC} = 1.59\text{ V} \pm 0.15\text{ V}$) are compared. When $V_{DD} < V_{POC}$, the internal reset signal is generated. It is released when $V_{DD} \geq V_{POC}$.

(2) In 2.7 V/1.59 V POC mode (option byte: POCMODE = 1)

- An internal reset signal is generated on power application. When the supply voltage (V_{DD}) exceeds the detection voltage ($V_{DDPOC} = 2.7\text{ V} \pm 0.2\text{ V}$), the reset status is released.
- The supply voltage (V_{DD}) and detection voltage ($V_{POC} = 1.59\text{ V} \pm 0.15\text{ V}$) are compared. When $V_{DD} < V_{POC}$, the internal reset signal is generated. It is released when $V_{DD} \geq V_{DDPOC}$.

<R>

The timing of generation of the internal reset signal by the power-on-clear circuit and low-voltage detector is shown below.

<R>

Figure 18-2. Timing of Generation of Internal Reset Signal by Power-on-Clear Circuit and Low-Voltage Detector (1/2)

(1) In 1.59 V POC mode (option byte: POCMODE = 0)

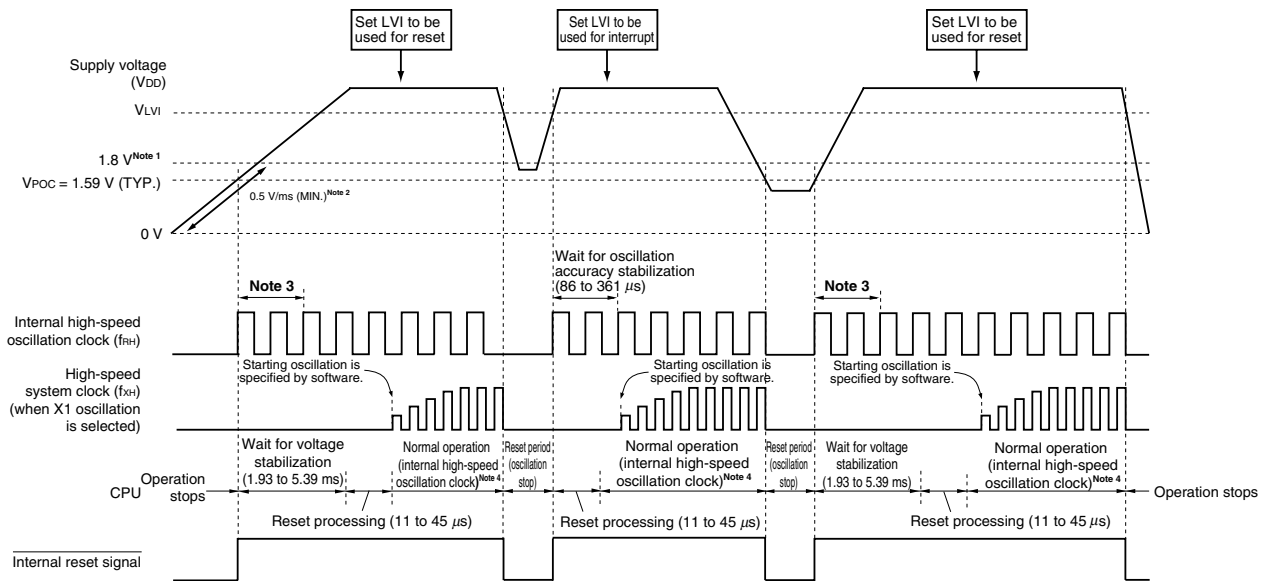

Notes 1. The operation guaranteed range is $1.8\text{ V} \leq V_{DD} \leq 5.5\text{ V}$. To make the state at lower than 1.8 V reset state when the supply voltage falls, use the reset function of the low-voltage detector, or input the low level to the $\overline{\text{RESET}}$ pin.

<R>

2. If the voltage rises to 1.8 V at a rate slower than 0.5 V/ms (MIN.) on power application, input a low level to the $\overline{\text{RESET}}$ pin after power application and before the voltage reaches 1.8 V, or set the 2.7 V/1.59 V POC mode by using an option byte (POCMODE = 1).

<R>

3. The internal voltage stabilization time includes the oscillation accuracy stabilization time of the internal high-speed oscillation clock.

4. The internal high-speed oscillation clock and a high-speed system clock or subsystem clock can be selected as the CPU clock. To use the X1 clock, use the OSTC register to confirm the lapse of the oscillation stabilization time. To use the XT1 clock, use the timer function for confirmation of the lapse of the stabilization time.

Caution Set the low-voltage detector by software after the reset status is released (see CHAPTER 19 LOW-VOLTAGE DETECTOR).

Remark V_{LVI} : LVI detection voltage
 V_{POC} : POC detection voltage

<R>

Figure 18-2. Timing of Generation of Internal Reset Signal by Power-on-Clear Circuit and Low-Voltage Detector (2/2)

(2) In 2.7 V/1.59 V POC mode (option byte: POCMODE = 1)

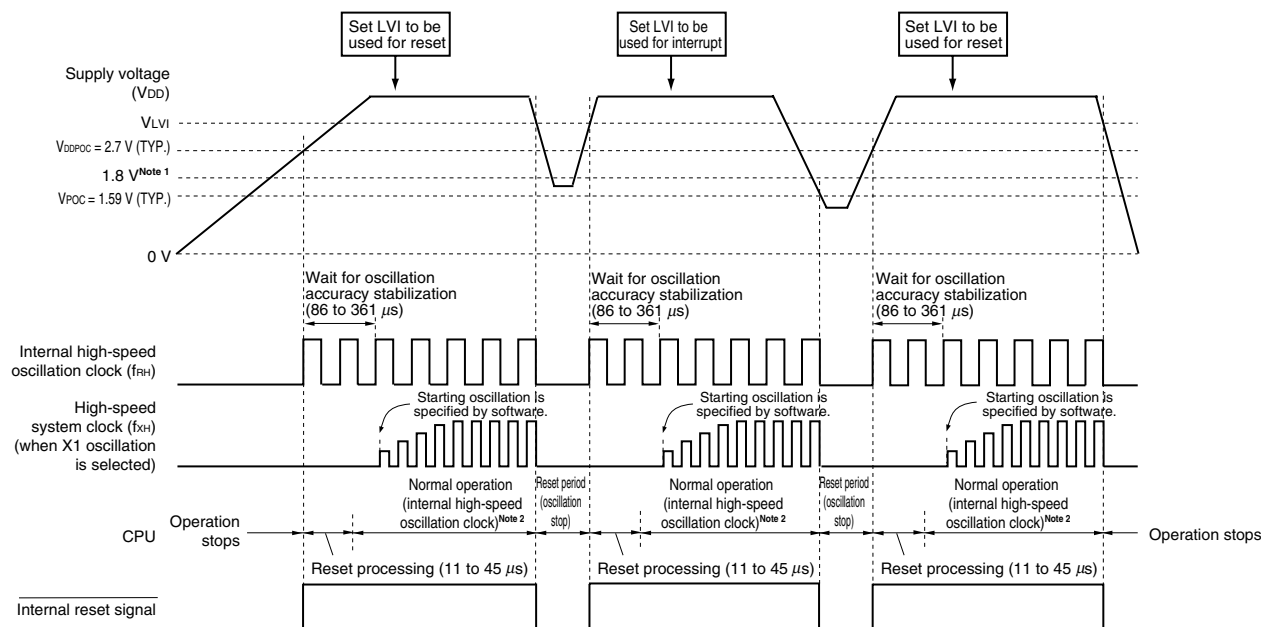

- Notes**
1. The operation guaranteed range is $1.8\text{ V} \leq V_{DD} \leq 5.5\text{ V}$. To make the state at lower than 1.8 V reset state when the supply voltage falls, use the reset function of the low-voltage detector, or input the low level to the $\overline{\text{RESET}}$ pin.
 2. The internal high-speed oscillation clock and a high-speed system clock or subsystem clock can be selected as the CPU clock. To use the X1 clock, use the OSTC register to confirm the lapse of the oscillation stabilization time. To use the XT1 clock, use the timer function for confirmation of the lapse of the stabilization time.

Cautions 1. Set the low-voltage detector by software after the reset status is released (see CHAPTER 19 LOW-VOLTAGE DETECTOR).

<R>

2. A voltage oscillation stabilization time of 1.93 to 5.39 ms is required after the supply voltage reaches 1.59 V (TYP.). If the supply voltage rises from 1.59 V (TYP.) to 2.7 V (TYP.) within 1.93 ms, the power supply oscillation stabilization time of 0 to 5.39 ms is automatically generated before reset processing.

Remark V_{LVI} : LVI detection voltage
 V_{POC} : POC detection voltage

18.4 Cautions for Power-on-Clear Circuit

In a system where the supply voltage (V_{DD}) fluctuates for a certain period in the vicinity of the POC detection voltage (V_{POC}), the system may be repeatedly reset and released from the reset status. In this case, the time from release of reset to the start of the operation of the microcontroller can be arbitrarily set by taking the following action.

<Action>

After releasing the reset signal, wait for the supply voltage fluctuation period of each system by means of a software counter that uses a timer, and then initialize the ports.

Figure 18-3. Example of Software Processing After Reset Release (1/2)

- If supply voltage fluctuation is 50 ms or less in vicinity of POC detection voltage

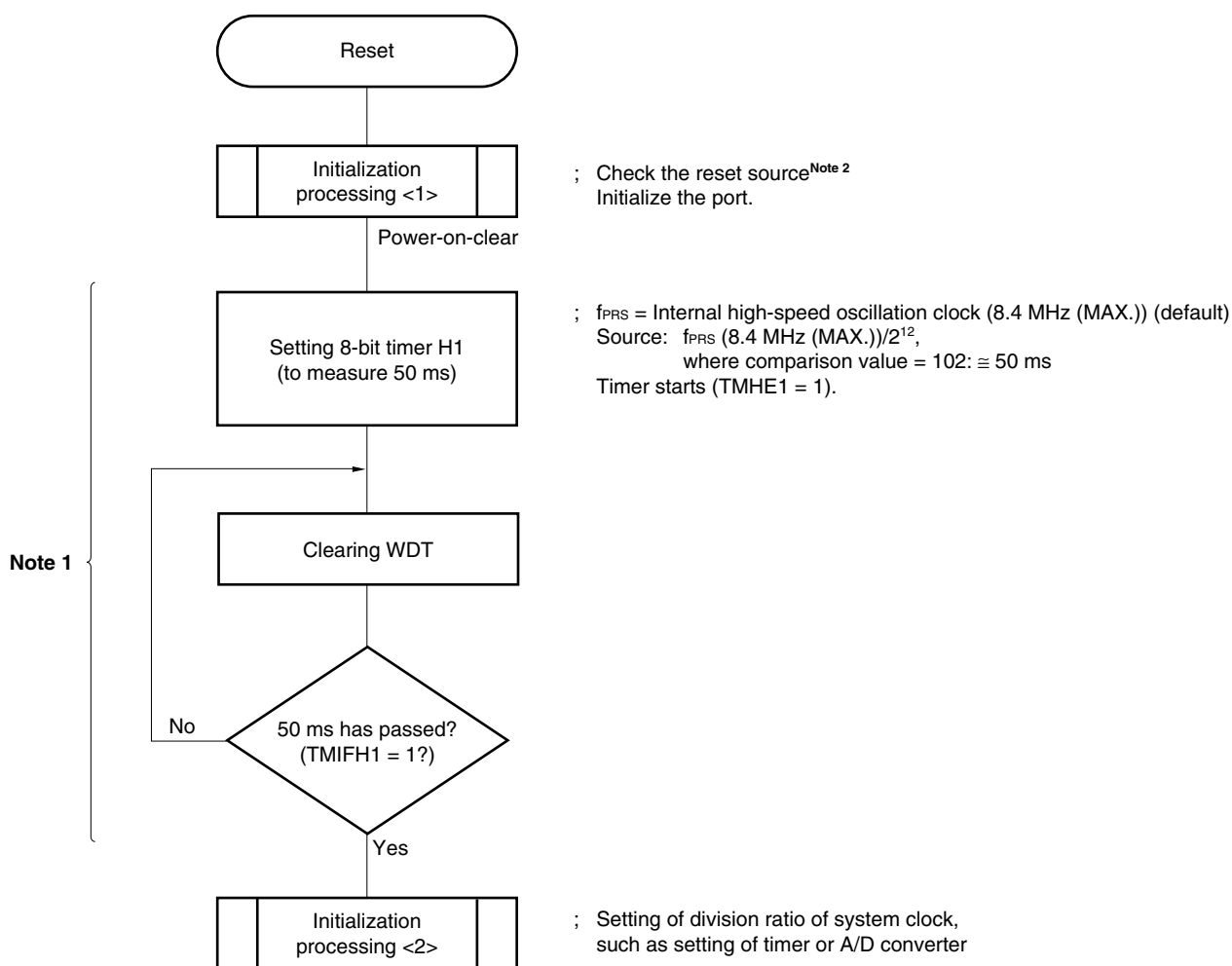

- Notes**
1. If reset is generated again during this period, initialization processing <2> is not started.
 2. A flowchart is shown on the next page.

Figure 18-3. Example of Software Processing After Reset Release (2/2)

- Checking reset source

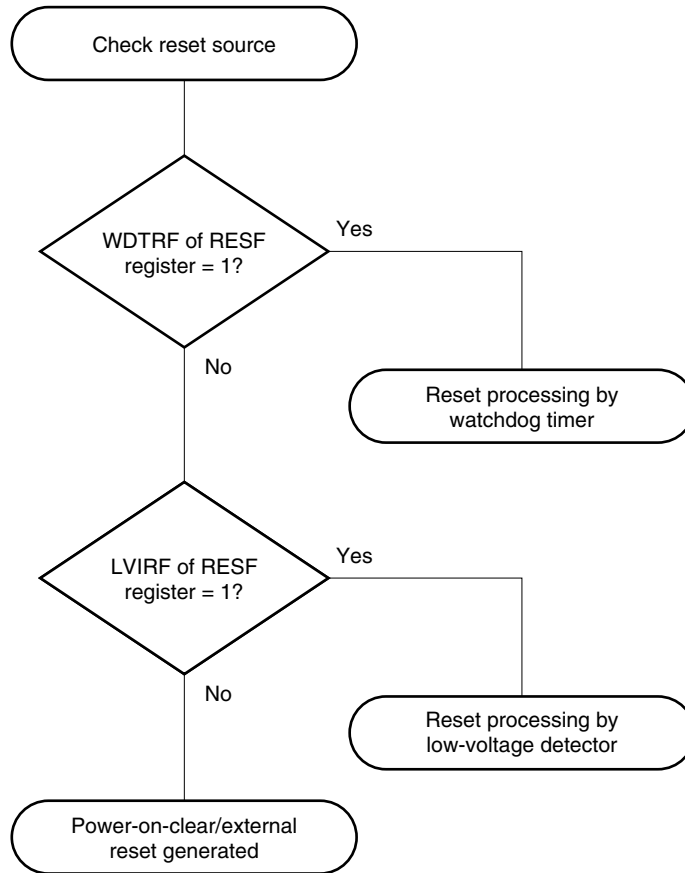

CHAPTER 19 LOW-VOLTAGE DETECTOR

19.1 Functions of Low-Voltage Detector

The low-voltage detector (LVI) has the following functions.

- The LVI circuit compares the supply voltage (V_{DD}) with the detection voltage (V_{LVI}) or the input voltage from an external input pin (EXLVI) with the detection voltage ($V_{EXLVI} = 1.21 \text{ V (TYP.)}$; fixed), and generates an internal reset or internal interrupt signal.
- The supply voltage (V_{DD}) or input voltage from an external input pin (EXLVI) can be selected by software.
- Reset or interrupt function can be selected by software.
- Detection levels (16 levels) of supply voltage can be changed by software.
- Operable in STOP mode.

<R> The reset and interrupt signals are generated as follows depending on selection by software.

Selection of Level Detection of Supply Voltage (V_{DD}) (LVISEL = 0)		Selection Level Detection of Input Voltage from External Input Pin (EXLVI) (LVISEL = 1)	
Selects reset (LVIMD = 1).	Selects interrupt (LVIMD = 0).	Selects reset (LVIMD = 1).	Selects interrupt (LVIMD = 0).
Generates an internal reset signal when $V_{DD} < V_{LVI}$ and releases the reset signal when $V_{DD} \geq V_{LVI}$.	Generates an internal interrupt signal when V_{DD} drops lower than V_{LVI} ($V_{DD} < V_{LVI}$) or when V_{DD} becomes V_{LVI} or higher ($V_{DD} \geq V_{LVI}$).	Generates an internal reset signal when $EXLVI < V_{EXLVI}$ and releases the reset signal when $EXLVI \geq V_{EXLVI}$.	Generates an internal interrupt signal when EXLVI drops lower than V_{EXLVI} ($EXLVI < V_{EXLVI}$) or when EXLVI becomes V_{EXLVI} or higher ($EXLVI \geq V_{EXLVI}$).

Remark LVISEL: Bit 2 of low-voltage detection register (LVIM)
LVIMD: Bit 1 of LVIM

<R> While the low-voltage detector is operating, whether the supply voltage or the input voltage from an external input pin is more than or less than the detection level can be checked by reading the low-voltage detection flag (LVIF: bit 0 of LVIM).

When the low-voltage detector is used to reset, bit 0 (LVIRF) of the reset control flag register (RESF) is set to 1 if reset occurs. For details of RESF, see **CHAPTER 17 RESET FUNCTION**.

19.2 Configuration of Low-Voltage Detector

The block diagram of the low-voltage detector is shown in Figure 19-1.

Figure 19-1. Block Diagram of Low-Voltage Detector

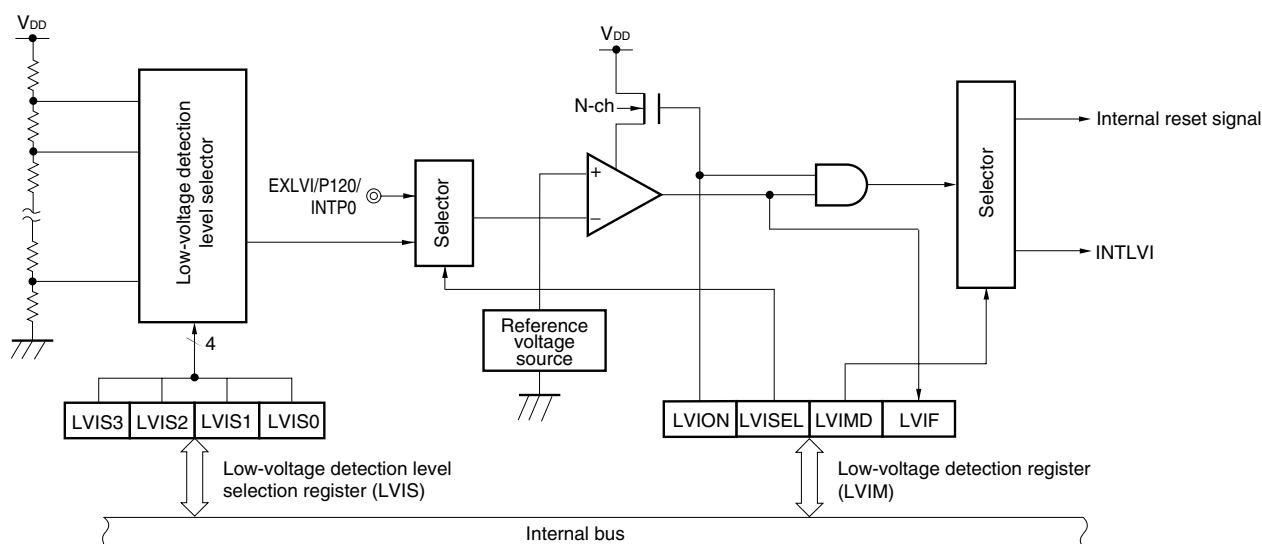

19.3 Registers Controlling Low-Voltage Detector

The low-voltage detector is controlled by the following registers.

- Low-voltage detection register (LVIM)
- Low-voltage detection level selection register (LVIS)
- Port mode register 12 (PM12)

(1) Low-voltage detection register (LVIM)

This register sets low-voltage detection and the operation mode.

This register can be set by a 1-bit or 8-bit memory manipulation instruction.

Reset signal generation sets LVIM to 00H.

Figure 19-2. Format of Low-Voltage Detection Register (LVIM)

Address: FFBEH After reset: 00H R/W^{Note 1}

Symbol	<7>	6	5	4	3	<2>	<1>	<0>
LVIM	LVION	0	0	0	0	LVISEL	LVIMD	LVIF

LVION ^{Notes 2, 3}	Enables low-voltage detection operation
0	Disables operation
1	Enables operation

LVISEL ^{Note 2}	Voltage detection selection
0	Detects level of supply voltage (V_{DD})
1	Detects level of input voltage from external input pin (EXLVI)

<R>

LVIMD ^{Note 2}	Low-voltage detection operation mode (interrupt/reset) selection
0	<ul style="list-style-type: none"> LVISEL = 0: Generates an internal interrupt signal when the supply voltage (V_{DD}) drops lower than the detection voltage (V_{LVI}) ($V_{DD} < V_{LVI}$) or when V_{DD} becomes V_{LVI} or higher ($V_{DD} \geq V_{LVI}$). LVISEL = 1: Generates an interrupt signal when the input voltage from an external input pin (EXLVI) drops lower than the detection voltage (V_{EXLVI}) ($EXLVI < V_{EXLVI}$) or when EXLVI becomes V_{EXLVI} or higher ($EXLVI \geq V_{EXLVI}$).
1	<ul style="list-style-type: none"> LVISEL = 0: Generates an internal reset signal when the supply voltage (V_{DD}) < detection voltage (V_{LVI}) and releases the reset signal when $V_{DD} \geq V_{LVI}$. LVISEL = 1: Generates an internal reset signal when the input voltage from an external input pin (EXLVI) < detection voltage (V_{EXLVI}) and releases the reset signal when $EXLVI \geq V_{EXLVI}$.

LVIF ^{Note 4}	Low-voltage detection flag
0	<ul style="list-style-type: none"> LVISEL = 0: Supply voltage (V_{DD}) \geq detection voltage (V_{LVI}), or when operation is disabled LVISEL = 1: Input voltage from external input pin (EXLVI) \geq detection voltage (V_{EXLVI}), or when operation is disabled
1	<ul style="list-style-type: none"> LVISEL = 0: Supply voltage (V_{DD}) < detection voltage (V_{LVI}) LVISEL = 1: Input voltage from external input pin (EXLVI) < detection voltage (V_{EXLVI})

- Notes**
1. Bit 0 is read-only.
 2. LVION, LVIMD, and LVISEL are cleared to 0 in the case of a reset other than an LVI reset. These are not cleared to 0 in the case of an LVI reset.
 3. When LVION is set to 1, operation of the comparator in the LVI circuit is started. Use software to wait for an operation stabilization time (10 μ s (MAX.)) when LVION is set to 1 until the voltage is confirmed at LVIF.
 4. The value of LVIF is output as the interrupt request signal INTLVI when LVION = 1 and LVIMD = 0.

- Cautions**
1. To stop LVI, follow either of the procedures below.
 - When using 8-bit memory manipulation instruction: Write 00H to LVIM.
 - When using 1-bit memory manipulation instruction: Clear LVION to 0.
 2. Input voltage from external input pin (EXLVI) must be $EXLVI < V_{DD}$.

(2) Low-voltage detection level selection register (LVIS)

This register selects the low-voltage detection level.

This register can be set by a 1-bit or 8-bit memory manipulation instruction.

Reset signal generation input sets LVIS to 00H.

Figure 19-3. Format of Low-Voltage Detection Level Selection Register (LVIS)

Address: FFBFH After reset: 00H R/W

Symbol	7	6	5	4	3	2	1	0
LVIS	0	0	0	0	LVIS3	LVIS2	LVIS1	LVIS0

LVIS3	LVIS2	LVIS1	LVIS0	Detection level
0	0	0	0	V_{LV10} (4.24 V \pm 0.1 V)
0	0	0	1	V_{LV11} (4.09 V \pm 0.1 V)
0	0	1	0	V_{LV12} (3.93 V \pm 0.1 V)
0	0	1	1	V_{LV13} (3.78 V \pm 0.1 V)
0	1	0	0	V_{LV14} (3.62 V \pm 0.1 V)
0	1	0	1	V_{LV15} (3.47 V \pm 0.1 V)
0	1	1	0	V_{LV16} (3.32 V \pm 0.1 V)
0	1	1	1	V_{LV17} (3.16 V \pm 0.1 V)
1	0	0	0	V_{LV18} (3.01 V \pm 0.1 V)
1	0	0	1	V_{LV19} (2.85 V \pm 0.1 V)
1	0	1	0	V_{LV110} (2.70 V \pm 0.1 V)
1	0	1	1	V_{LV111} (2.55 V \pm 0.1 V)
1	1	0	0	V_{LV112} (2.39 V \pm 0.1 V)
1	1	0	1	V_{LV113} (2.24 V \pm 0.1 V)
1	1	1	0	V_{LV114} (2.08 V \pm 0.1 V)
1	1	1	1	V_{LV115} (1.93 V \pm 0.1 V)

Cautions 1. Be sure to clear bits 4 to 7 to 0.

2. Do not change the value of LVIS during LVI operation.

3. When an input voltage from the external input pin (EXLVI) is detected, the detection voltage ($V_{EXLVI} = 1.21$ V (TYP.)) is fixed. Therefore, setting of LVIS is not necessary.

(3) Port mode register 12 (PM12)

When using the P120/EXLVI/INTP0 pin for external low-voltage detection potential input, set PM120 to 1. At this time, the output latch of P120 may be 0 or 1.

PM12 can be set by a 1-bit or 8-bit memory manipulation instruction.

Reset signal generation sets PM12 to FFH.

Figure 19-4. Format of Port Mode Register 12 (PM12)

Address: FF2CH	After reset: FFH	R/W						
Symbol	7	6	5	4	3	2	1	0
PM12	1	1	1	1	1	PM122	PM121	PM120

PM12n	P12n pin I/O mode selection (n = 0 to 2)
0	Output mode (output buffer on)
1	Input mode (output buffer off)

19.4 Operation of Low-Voltage Detector

The low-voltage detector can be used in the following two modes.

<R>

(1) Used as reset (LVIMD = 1)

- If LVISEL = 0, compares the supply voltage (V_{DD}) and detection voltage (V_{LVI}), generates an internal reset signal when $V_{DD} < V_{LVI}$, and releases internal reset when $V_{DD} \geq V_{LVI}$.
- If LVISEL = 1, compares the input voltage from external input pin (EXLVI) and detection voltage ($V_{EXLVI} = 1.21$ V (TYP.)), generates an internal reset signal when $EXLVI < V_{EXLVI}$, and releases internal reset when $EXLVI \geq V_{EXLVI}$.

<R>

(2) Used as interrupt (LVIMD = 0)

- If LVISEL = 0, compares the supply voltage (V_{DD}) and detection voltage (V_{LVI}). When V_{DD} drops lower than V_{LVI} ($V_{DD} < V_{LVI}$) or when V_{DD} becomes V_{LVI} or higher ($V_{DD} \geq V_{LVI}$), generates an interrupt signal (INTLVI).
- If LVISEL = 1, compares the input voltage from external input pin (EXLVI) and detection voltage ($V_{EXLVI} = 1.21$ V (TYP.)). When EXLVI drops lower than V_{EXLVI} ($EXLVI < V_{EXLVI}$) or when EXLVI becomes V_{EXLVI} or higher ($EXLVI \geq V_{EXLVI}$), generates an interrupt signal (INTLVI).

<R>

While the low-voltage detector is operating, whether the supply voltage or the input voltage from an external input pin is more than or less than the detection level can be checked by reading the low-voltage detection flag (LVIF: bit 0 of LVIM).

Remark LVIMD: Bit 1 of low-voltage detection register (LVIM)
LVISEL: Bit 2 of LVIM

19.4.1 When used as reset

(1) When detecting level of supply voltage (V_{DD})

- When starting operation
 - <1> Mask the LVI interrupt ($LVIMK = 1$).
 - <2> Clear bit 2 (LVISEL) of the low-voltage detection register (LVIM) to 0 (detects level of supply voltage (V_{DD})) (default value).
 - <3> Set the detection voltage using bits 3 to 0 (LVIS3 to LVIS0) of the low-voltage detection level selection register (LVIS).
 - <4> Set bit 7 (LVION) of LVIM to 1 (enables LVI operation).
 - <5> Use software to wait for an operation stabilization time (10 μ s (MAX.)).
 - <6> Wait until it is checked that (supply voltage (V_{DD}) \geq detection voltage (V_{LVI})) by bit 0 (LVIF) of LVIM.
 - <7> Set bit 1 (LVIMD) of LVIM to 1 (generates reset when the level is detected).

Figure 19-5 shows the timing of the internal reset signal generated by the low-voltage detector. The numbers in this timing chart correspond to <1> to <7> above.

- Cautions**
1. <1> must always be executed. When $LVIMK = 0$, an interrupt may occur immediately after the processing in <4>.
 2. If supply voltage (V_{DD}) \geq detection voltage (V_{LVI}) when LVIMD is set to 1, an internal reset signal is not generated.

- When stopping operation
 - Either of the following procedures must be executed.
 - When using 8-bit memory manipulation instruction:
Write 00H to LVIM.
 - When using 1-bit memory manipulation instruction:
Clear LVIMD to 0 and then LVION to 0.

Figure 19-5. Timing of Low-Voltage Detector Internal Reset Signal Generation (Detects Level of Supply Voltage (V_{DD})) (1/2)

(1) In 1.59 V POC mode (option byte: POCMODE = 0)

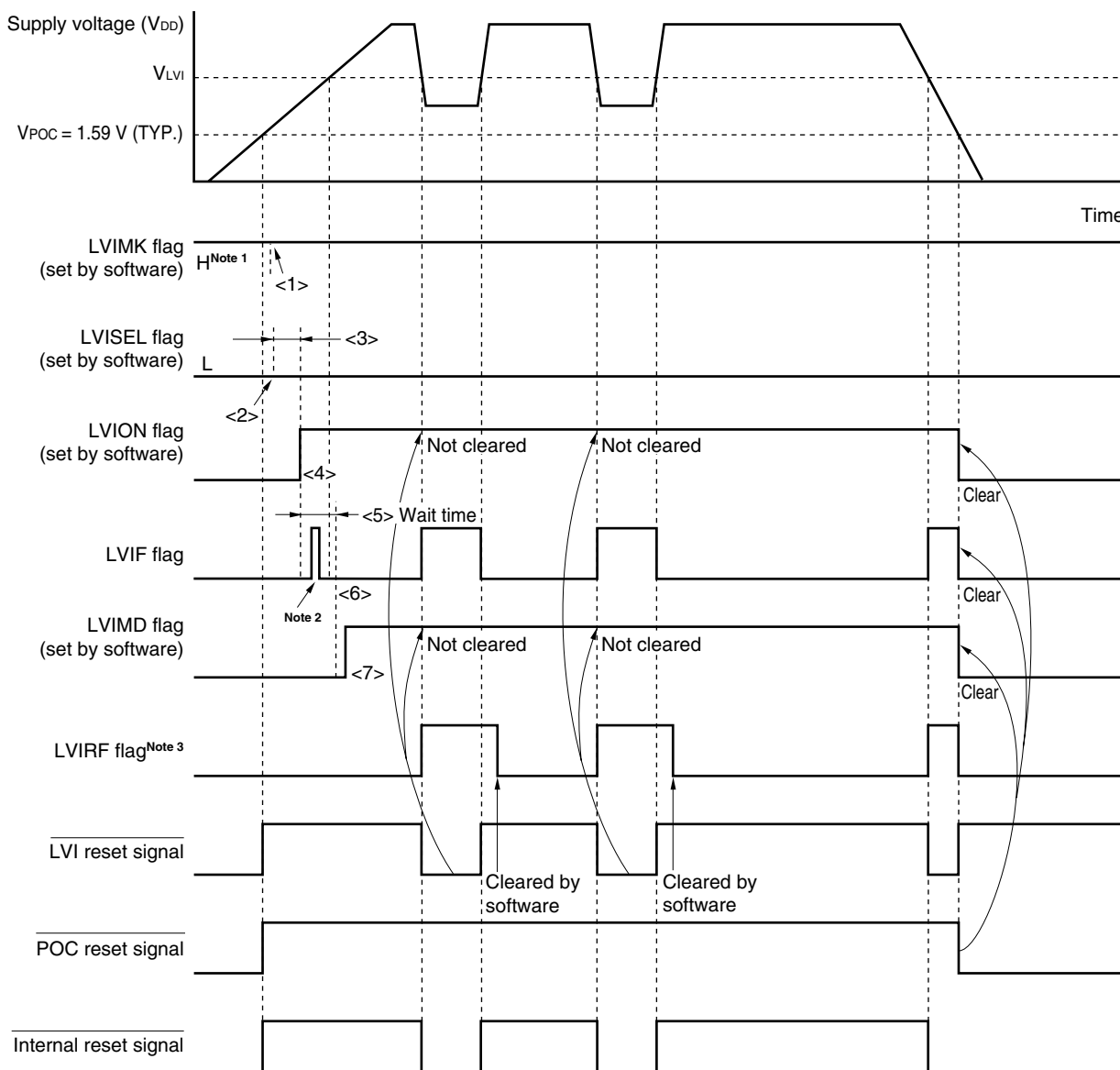

- Notes**
1. The LVIMK flag is set to “1” by reset signal generation.
 2. The LVIF flag may be set (1).
 3. LVIRF is bit 0 of the reset control flag register (RESF). For details of RESF, see **CHAPTER 17 RESET FUNCTION**.

Remark <1> to <7> in Figure 19-5 above correspond to <1> to <7> in the description of “When starting operation” in **19.4.1 (1) When detecting level of supply voltage (V_{DD})**.

Figure 19-5. Timing of Low-Voltage Detector Internal Reset Signal Generation (Detects Level of Supply Voltage (V_{DD})) (2/2)

(2) In 2.7 V/1.59 V POC mode (option byte: POCMODE = 1)

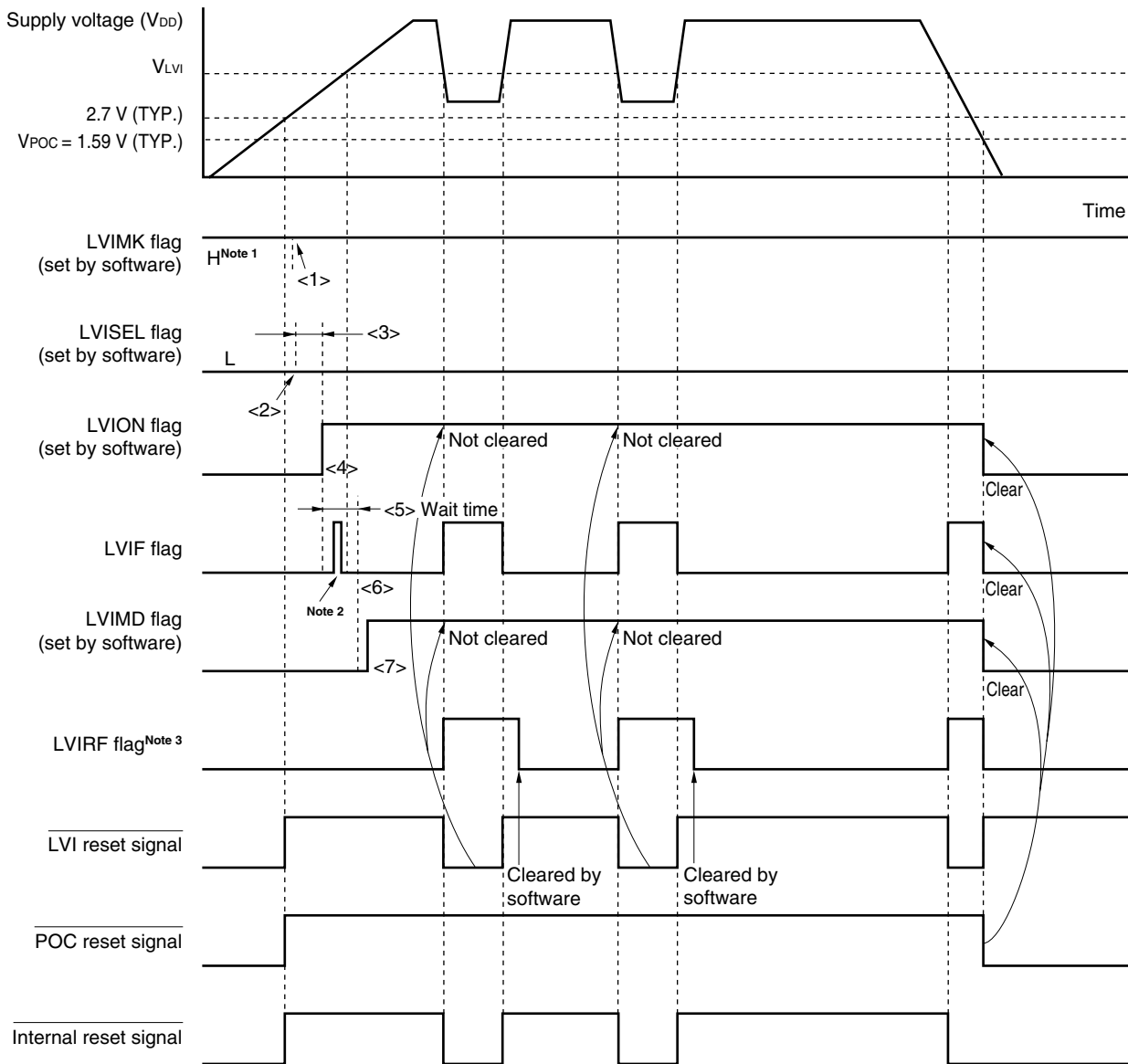

- Notes**
1. The LVIMK flag is set to “1” by reset signal generation.
 2. The LVIF flag may be set (1).
 3. LVIRF is bit 0 of the reset control flag register (RESF). For details of RESF, see **CHAPTER 17 RESET FUNCTION**.

Remark <1> to <7> in Figure 19-5 above correspond to <1> to <7> in the description of “When starting operation” in 19.4.1 (1) **When detecting level of supply voltage (V_{DD})**.

(2) When detecting level of input voltage from external input pin (EXLVI)

- When starting operation
 - <1> Mask the LVI interrupt (LVIMK = 1).
 - <2> Set bit 2 (LVISEL) of the low-voltage detection register (LVIM) to 1 (detects level of input voltage from external input pin (EXLVI)).
 - <3> Set bit 7 (LVION) of LVIM to 1 (enables LVI operation).
 - <4> Use software to wait for an operation stabilization time (10 μ s (MAX.)^{Note}).
 - <5> Wait until it is checked that (input voltage from external input pin (EXLVI) \geq detection voltage ($V_{EXLVI} = 1.21$ V (TYP.))) by bit 0 (LVIF) of LVIM.
 - <6> Set bit 1 (LVIMD) of LVIM to 1 (generates reset signal when the level is detected).

Figure 19-6 shows the timing of the internal reset signal generated by the low-voltage detector. The numbers in this timing chart correspond to <1> to <6> above.

Cautions 1. <1> must always be executed. When LVIMK = 0, an interrupt may occur immediately after the processing in <3>.

2. If input voltage from external input pin (EXLVI) \geq detection voltage ($V_{EXLVI} = 1.21$ V (TYP.)) when LVIMD is set to 1, an internal reset signal is not generated.

3. Input voltage from external input pin (EXLVI) must be $EXLVI < V_{DD}$.

- When stopping operation

Either of the following procedures must be executed.

 - When using 8-bit memory manipulation instruction:
Write 00H to LVIM.
 - When using 1-bit memory manipulation instruction:
Clear LVIMD to 0 and then LVION to 0.

Figure 19-6. Timing of Low-Voltage Detector Internal Reset Signal Generation (Detects Level of Input Voltage from External Input Pin (EXLVI))

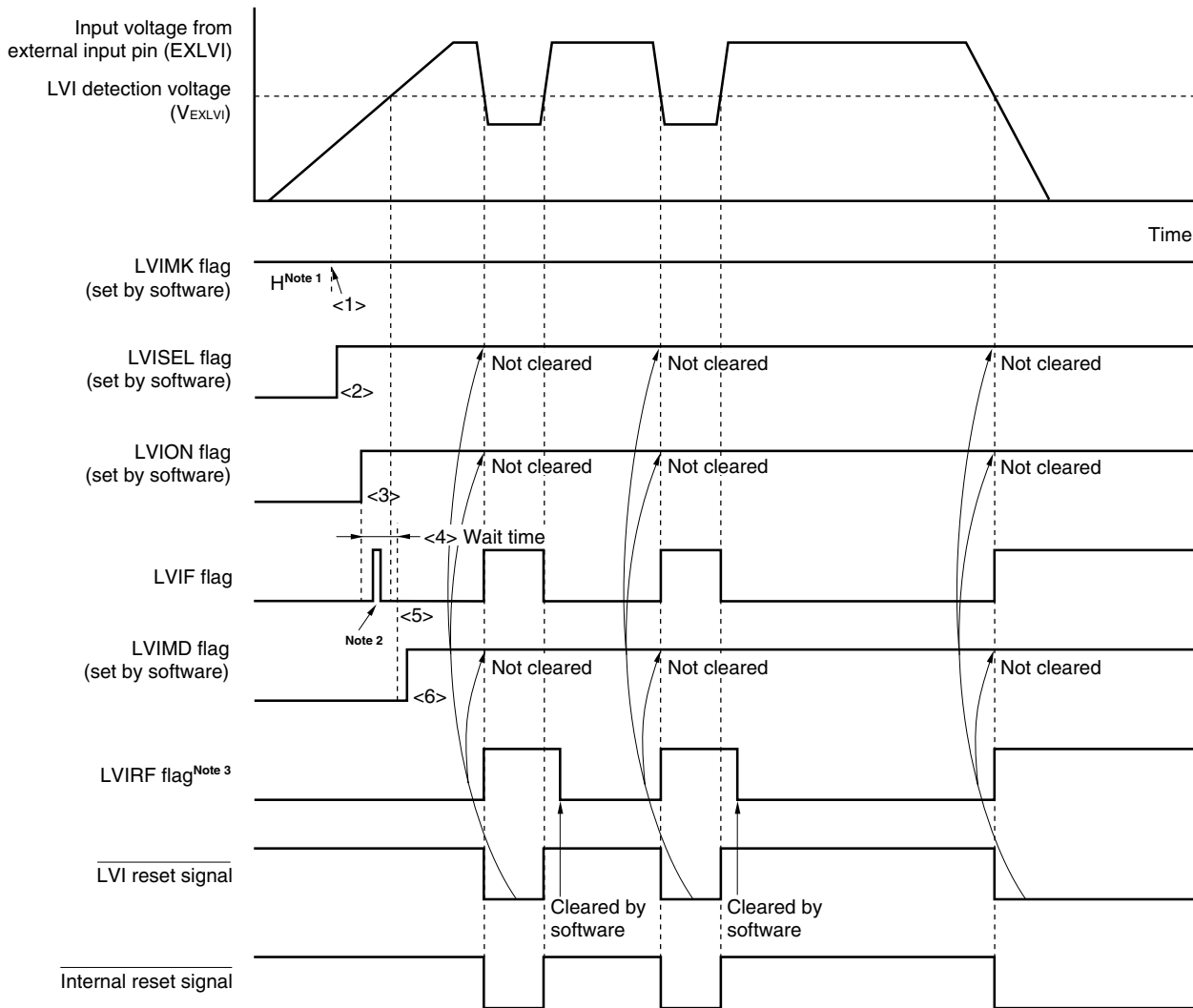

- Notes**
1. The LVIMK flag is set to “1” by reset signal generation.
 2. The LVIF flag may be set (1).
 3. LVIRF is bit 0 of the reset control flag register (RESF). For details of RESF, see **CHAPTER 17 RESET FUNCTION**.

Remark <1> to <6> in Figure 19-6 above correspond to <1> to <6> in the description of “When starting operation” in **19.4.1 (2) When detecting level of input voltage from external input pin (EXLVI)**.

19.4.2 When used as interrupt

(1) When detecting level of supply voltage (V_{DD})

- When starting operation
 - <1> Mask the LVI interrupt ($LVIMK = 1$).
 - <2> Clear bit 2 (LVISEL) of the low-voltage detection register (LVIM) to 0 (detects level of supply voltage (V_{DD})) (default value).
 - <3> Set the detection voltage using bits 3 to 0 (LVIS3 to LVIS0) of the low-voltage detection level selection register (LVIS).
 - <4> Set bit 7 (LVION) of LVIM to 1 (enables LVI operation).
 - <5> Use software to wait for an operation stabilization time (10 μ s (MAX.)).
 - <6> Confirm that “supply voltage (V_{DD}) \geq detection voltage (V_{LVI})” when detecting the falling edge of V_{DD} , or “supply voltage (V_{DD}) $<$ detection voltage (V_{LVI})” when detecting the rising edge of V_{DD} , at bit 0 (LVIF) of LVIM.
 - <7> Clear the interrupt request flag of LVI (LVIIF) to 0.
 - <8> Release the interrupt mask flag of LVI (LVIMK).
 - <9> Clear bit 1 (LVIMD) of LVIM to 0 (generates interrupt signal when the level is detected) (default value).
 - <10> Execute the EI instruction (when vector interrupts are used).

<R>

Figure 19-7 shows the timing of the interrupt signal generated by the low-voltage detector. The numbers in this timing chart correspond to <1> to <9> above.

- When stopping operation

Either of the following procedures must be executed.

 - When using 8-bit memory manipulation instruction:

Write 00H to LVIM.
 - When using 1-bit memory manipulation instruction:

Clear LVION to 0.

<R>

Figure 19-7. Timing of Low-Voltage Detector Interrupt Signal Generation (Detects Level of Supply Voltage (V_{DD})) (1/2)

(1) In 1.59 V POC mode (option byte: POCMODE = 0)

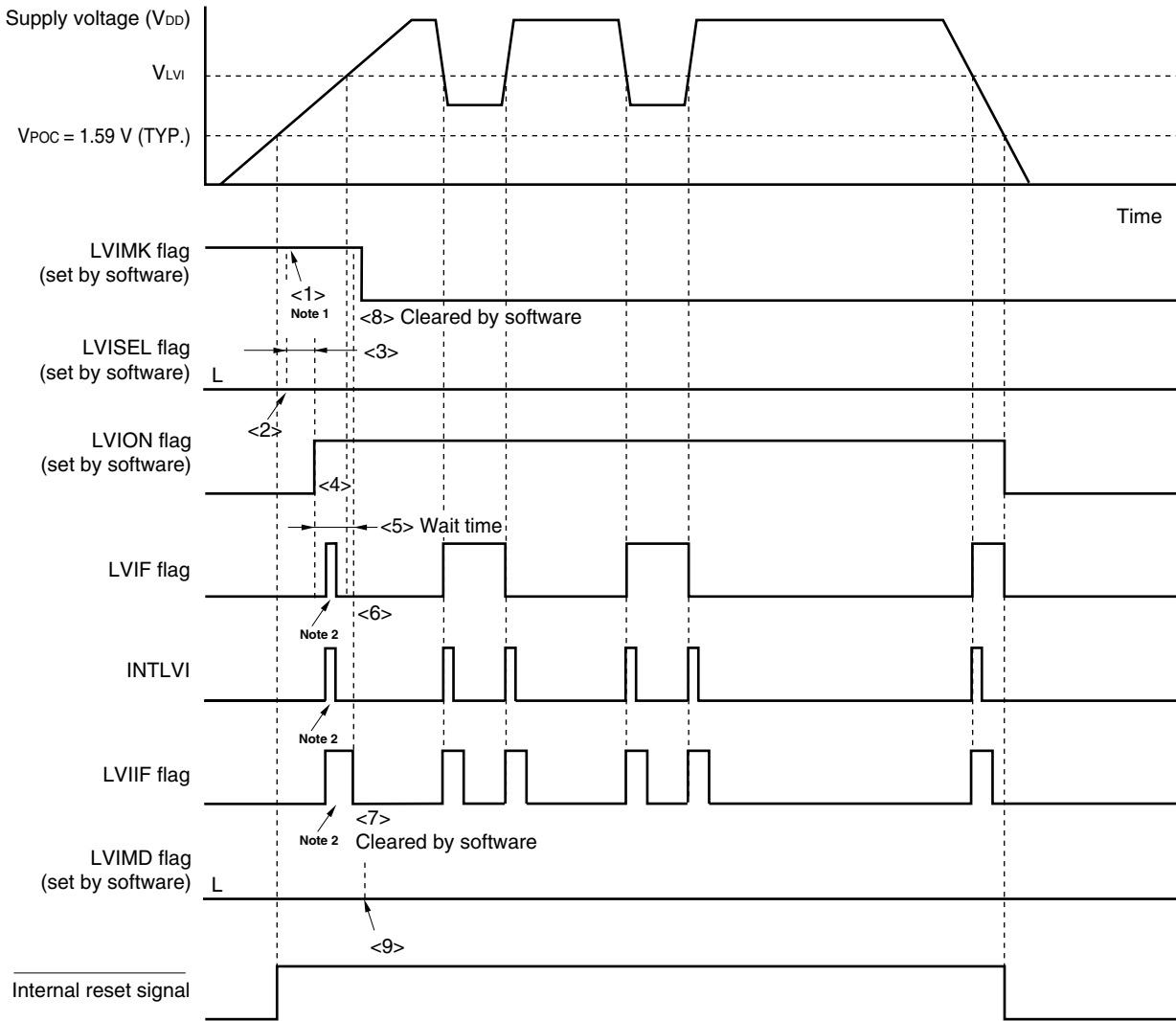

- Notes**
1. The LVIMK flag is set to "1" by reset signal generation.
 2. The interrupt request signal (INTLVI) is generated and the LVIF and LVIIF flags may be set (1).

Remark <1> to <9> in Figure 19-7 above correspond to <1> to <9> in the description of "When starting operation" in 19.4.2 (1) When detecting level of supply voltage (V_{DD}).

<R>

Figure 19-7. Timing of Low-Voltage Detector Interrupt Signal Generation (Detects Level of Supply Voltage (V_{DD})) (2/2)

(2) In 2.7 V/1.59 V POC mode (option byte: POCMODE = 1)

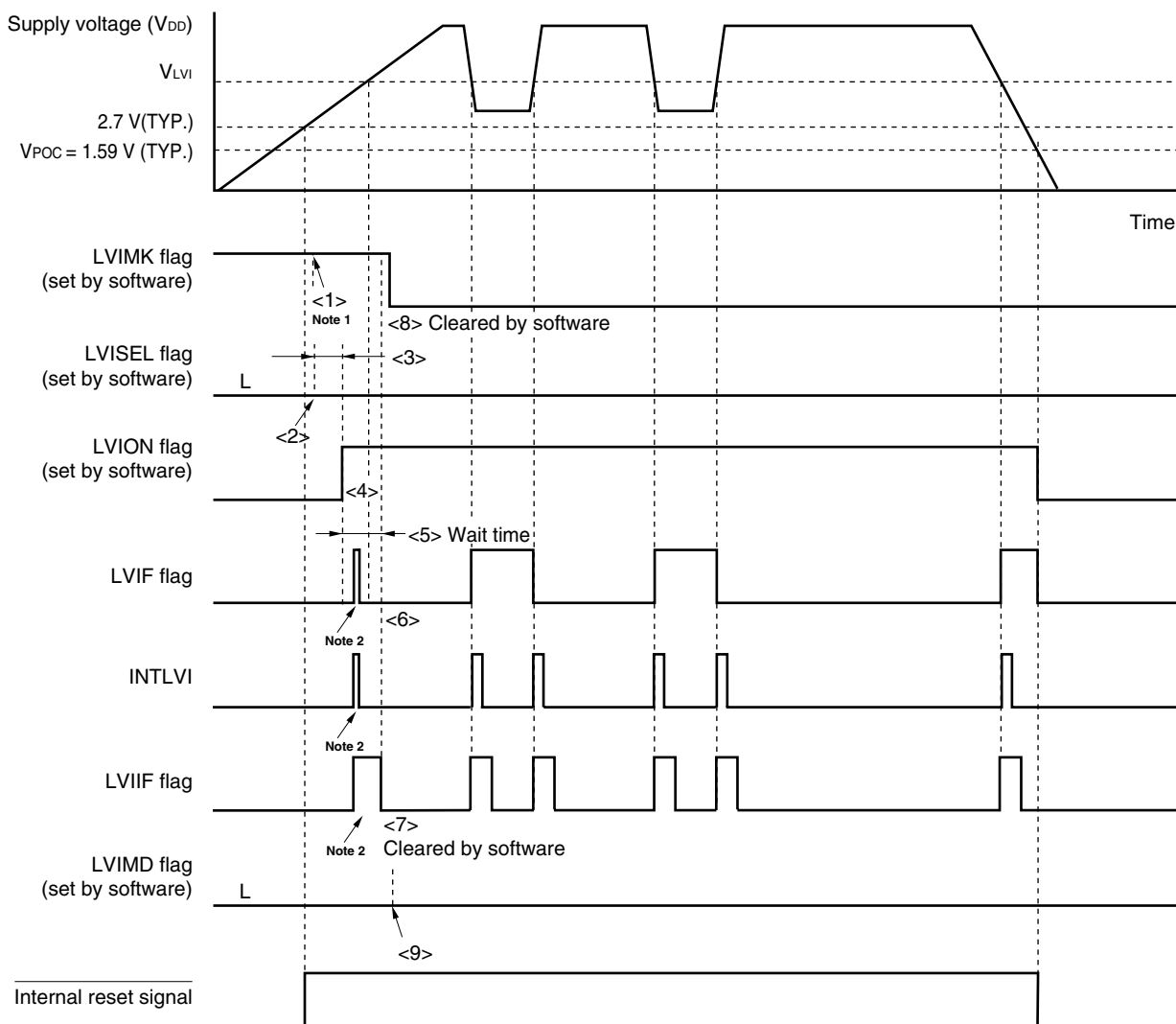

- Notes**
1. The LVIMK flag is set to “1” by reset signal generation.
 2. The interrupt request signal (INTLVI) is generated and the LVIF and LVIIF flags may be set (1).

Remark <1> to <9> in Figure 19-7 above correspond to <1> to <9> in the description of “When starting operation” in 19.4.2 (1) When detecting level of supply voltage (V_{DD}).

(2) When detecting level of input voltage from external input pin (EXLVI)

- When starting operation
 - <1> Mask the LVI interrupt (LVIMK = 1).
 - <2> Set bit 2 (LVISEL) of the low-voltage detection register (LVIM) to 1 (detects level of input voltage from external input pin (EXLVI)).
 - <3> Set bit 7 (LVION) of LVIM to 1 (enables LVI operation).
 - <4> Use software to wait for an operation stabilization time (10 μ s (MAX.)).
 - <R> <5> Confirm that “input voltage from external input pin (EXLVI) \geq detection voltage ($V_{EXLVI} = 1.21$ V (TYP.))” when detecting the falling edge of EXLVI, or “input voltage from external input pin (EXLVI) < detection voltage ($V_{EXLVI} = 1.21$ V (TYP.))” when detecting the rising edge of EXLVI, at bit 0 (LVIF) of LVIM.
 - <6> Clear the interrupt request flag of LVI (LVIF) to 0.
 - <7> Release the interrupt mask flag of LVI (LVIMK).
 - <8> Clear bit 1 (LVIMD) of LVIM to 0 (generates interrupt signal when the level is detected) (default value).
 - <9> Execute the EI instruction (when vector interrupts are used).

Figure 19-8 shows the timing of the interrupt signal generated by the low-voltage detector. The numbers in this timing chart correspond to <1> to <8> above.

Caution Input voltage from external input pin (EXLVI) must be $EXLVI < V_{DD}$.

- When stopping operation
 - Either of the following procedures must be executed.
 - When using 8-bit memory manipulation instruction:
 - Write 00H to LVIM.
 - When using 1-bit memory manipulation instruction:
 - Clear LVION to 0.

<R>

**Figure 19-8. Timing of Low-Voltage Detector Interrupt Signal Generation
(Detects Level of Input Voltage from External Input Pin (EXLVI))**

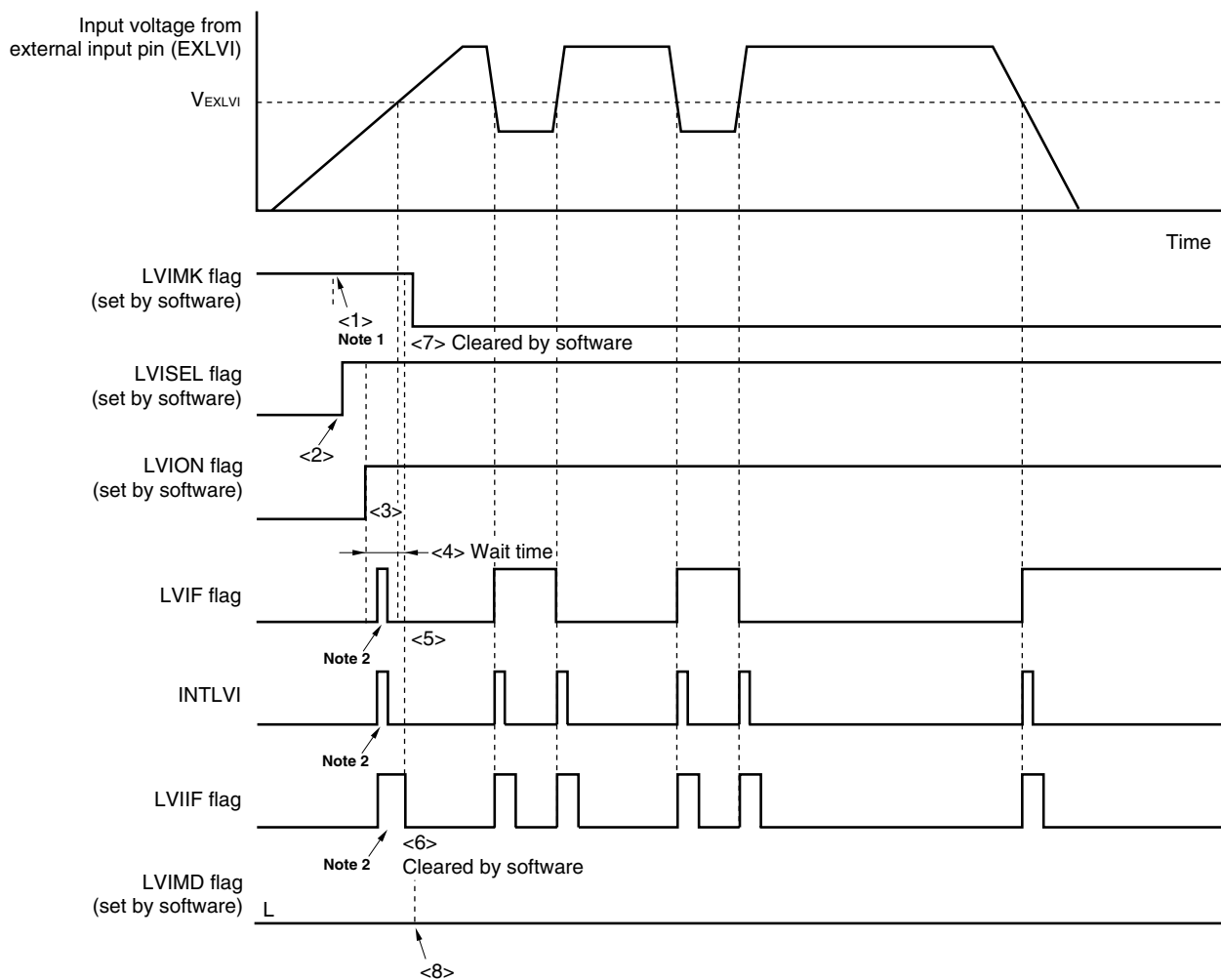

- Notes**
1. The LVIMK flag is set to "1" by reset signal generation.
 2. The interrupt request signal (INTLVI) is generated and the LVIF and LVIIF flags may be set (1).

Remark <1> to <8> in Figure 19-8 above correspond to <1> to <8> in the description of "When starting operation" in 19.4.2 (1) When detecting level of supply voltage (V_{DD}).

19.5 Cautions for Low-Voltage Detector

In a system where the supply voltage (V_{DD}) fluctuates for a certain period in the vicinity of the LVI detection voltage (V_{LVI}), the operation is as follows depending on how the low-voltage detector is used.

(1) When used as reset

The system may be repeatedly reset and released from the reset status.

In this case, the time from release of reset to the start of the operation of the microcontroller can be arbitrarily set by taking action (1) below.

(2) When used as interrupt

Interrupt requests may be frequently generated. Take (b) of action (2) below.

In this system, take the following actions.

<Action>

(1) When used as reset

After releasing the reset signal, wait for the supply voltage fluctuation period of each system by means of a software counter that uses a timer, and then initialize the ports (see **Figure 19-9**).

(2) When used as interrupt

<R> (a) Confirm that “supply voltage (V_{DD}) \geq detection voltage (V_{LVI})” when detecting the falling edge of V_{DD} , or “supply voltage (V_{DD}) $<$ detection voltage (V_{LVI})” when detecting the rising edge of V_{DD} , in the servicing routine of the LVI interrupt by using bit 0 (LVIF) of the low-voltage detection register (LVIM). Clear bit 0 (LVIIF) of interrupt request flag register 0L (IF0L) to 0.

<R> (b) In a system where the supply voltage fluctuation period is long in the vicinity of the LVI detection voltage, wait for the supply voltage fluctuation period, confirm that “supply voltage (V_{DD}) \geq detection voltage (V_{LVI})” when detecting the falling edge of V_{DD} , or “supply voltage (V_{DD}) $<$ detection voltage (V_{LVI})” when detecting the rising edge of V_{DD} , using the LVIF flag, and clear the LVIIF flag to 0.

Remark If bit 2 (LVISEL) of the low voltage detection register (LVIM) is set to “1”, the meanings of the above words change as follows.

- Supply voltage (V_{DD}) → Input voltage from external input pin (EXLVI)
- Detection voltage (V_{LVI}) → Detection voltage ($V_{EXLVI} = 1.21$ V)

Figure 19-9. Example of Software Processing After Reset Release (1/2)

- If supply voltage fluctuation is 50 ms or less in vicinity of LVI detection voltage

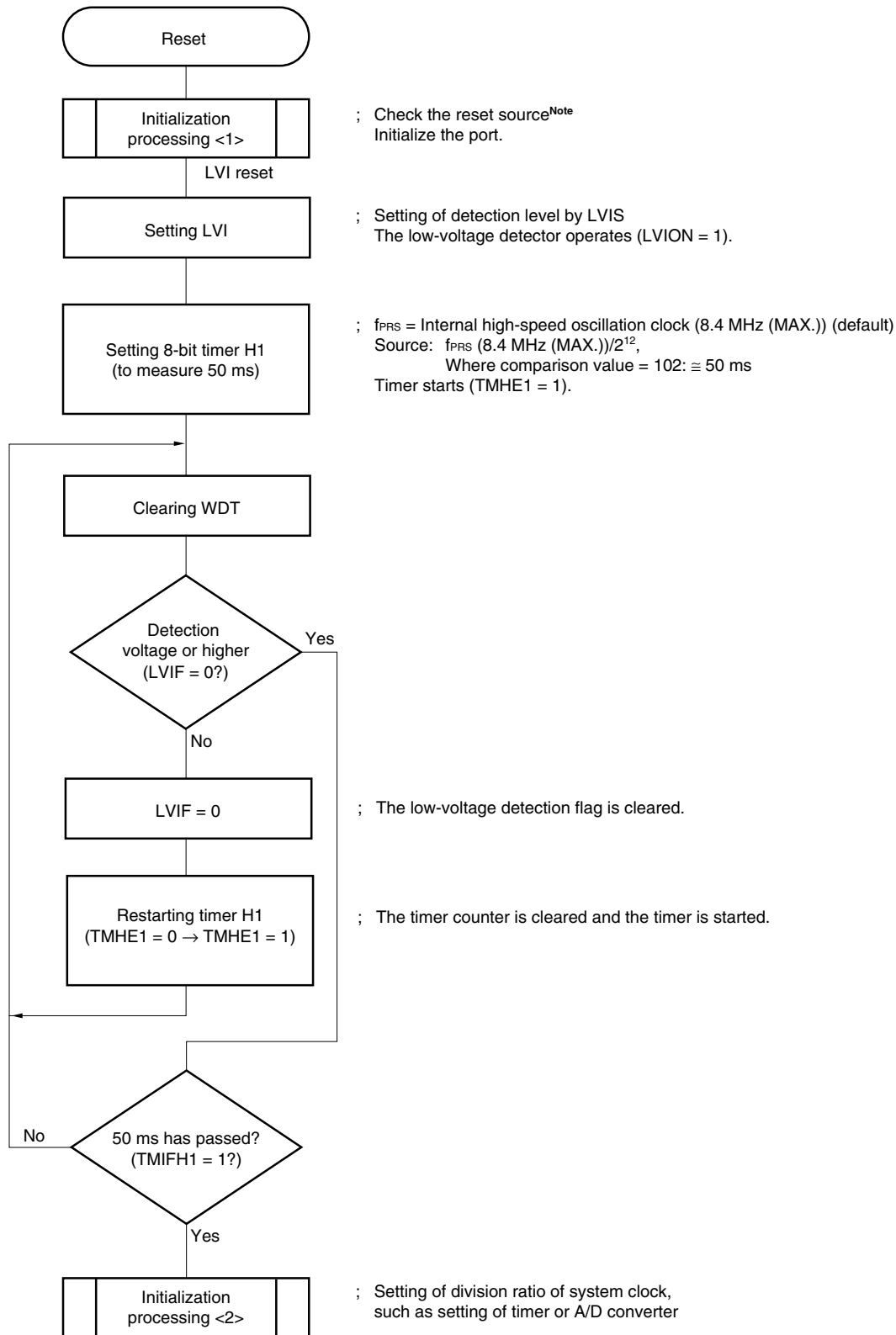

Note A flowchart is shown on the next page.

Figure 19-9. Example of Software Processing After Reset Release (2/2)

- Checking reset source

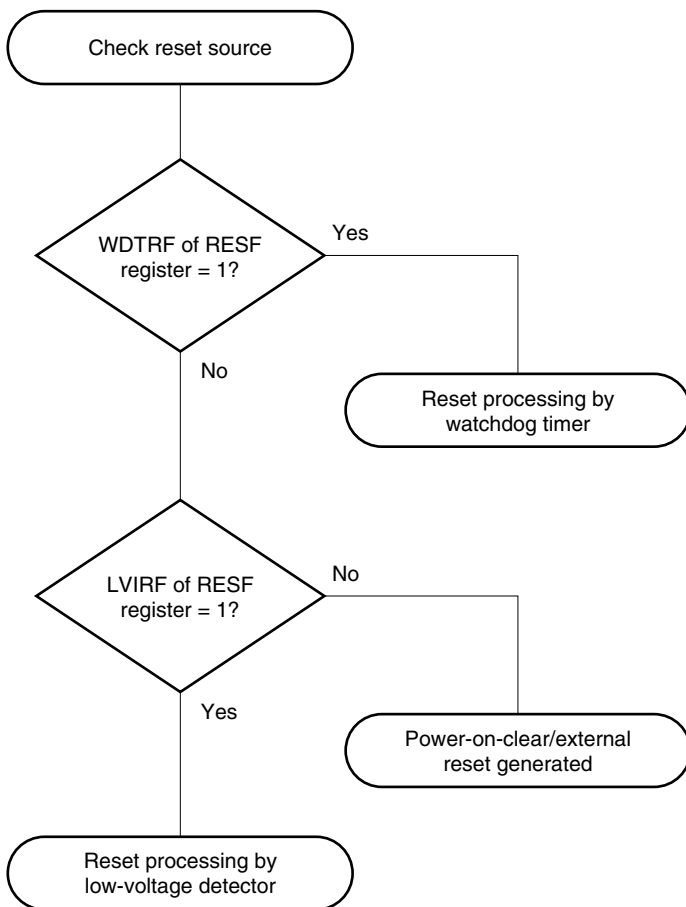

CHAPTER 20 OPTION BYTE

20.1 Functions of Option Bytes

The flash memory at 0080H to 0084H of the 78K0/KB2 is an option byte area. When power is turned on or when the device is restarted from the reset status, the device automatically references the option bytes and sets specified functions. When using the product, be sure to set the following functions by using the option bytes.

When the boot swap operation is used during self-programming, 0080H to 0084H are switched to 1080H to 1084H. Therefore, set values that are the same as those of 0080H to 0084H to 1080H to 1084H in advance.

Caution Be sure to set 00H to 0082H and 0083H (0082H/1082H and 0083H/1083H when the boot swap function is used).

(1) 0080H/1080H

- Internal low-speed oscillator operation
 - Can be stopped by software
 - Cannot be stopped
- Watchdog timer interval time setting
- Watchdog timer counter operation
 - Enabled counter operation
 - Disabled counter operation
- Watchdog timer window open period setting

<R> **Caution** Set a value that is the same as that of 0080H to 1080H because 0080H and 1080H are switched during the boot swap operation.

(2) 0081H/1081H

- Selecting POC mode
 - During 2.7 V/1.59 V POC mode operation (POCMODE = 1)
The device is in the reset state upon power application and until the supply voltage reaches 2.7 V (TYP.). It is released from the reset state when the voltage exceeds 2.7 V (TYP.). After that, POC is not detected at 2.7 V but is detected at 1.59 V (TYP.).
 - <R> If the supply voltage rises to 1.8 V after power application at a pace slower than 0.5 V/ms (MIN.), use of the 2.7 V/1.59 V POC mode is recommended.
 - During 1.59 V POC mode operation (POCMODE = 0)
The device is in the reset state upon power application and until the supply voltage reaches 1.59 V (TYP.). It is released from the reset state when the voltage exceeds 1.59 V (TYP.). After that, POC is detected at 1.59 V (TYP.), in the same manner as on power application.

<R> **Caution** POCMODE can only be written by using a dedicated flash memory programmer. It cannot be set during self-programming or boot swap operation during self-programming (at this time, 1.59 V POC mode (default) is set). However, because the value of 1081H is copied to 0081H during the boot swap operation, it is recommended to set a value that is the same as that of 0081H to 1081H when the boot swap function is used.

(3) 0084H/1084H

- On-chip debug operation control
 - Disabling on-chip debug operation
 - Enabling on-chip debug operation and erasing data of the flash memory in case authentication of the on-chip debug security ID fails
 - Enabling on-chip debug operation and not erasing data of the flash memory even in case authentication of the on-chip debug security ID fails

- Cautions**
1. Be sure to set 00H (disabling on-chip debug operation) to 0084H for products not equipped with the on-chip debug function (μ PD78F0500, 78F0501, 78F0502, and 78F0503). Also set 00H to 1084H because 0084H and 1084H are switched at boot swapping.
 2. To use the on-chip debug function with a product equipped with the on-chip debug function (μ PD78F0503D), set 02H or 03H to 0084H. Set a value that is the same as that of 0084H to 1084H because 0084H and 1084H are switched at boot swapping.

20.2 Format of Option Byte

The format of the option byte is shown below.

Figure 20-1. Format of Option Byte (1/2)

Address: 0080H/1080H^{Note}

7	6	5	4	3	2	1	0
0	WINDOW1	WINDOW0	WDTON	WDCS2	WDCS1	WDCS0	LSROSC
WINDOW1	WINDOW0	Watchdog timer window open period					
0	0	25%					
0	1	50%					
1	0	75%					
1	1	100%					
WDTON	Operation control of watchdog timer counter/illegal access detection						
0	Counter operation disabled (counting stopped after reset), illegal access detection operation disabled						
1	Counter operation enabled (counting started after reset), illegal access detection operation enabled						
WDCS2	WDCS1	WDCS0	Watchdog timer overflow time				
0	0	0	$2^{10}/f_{RL}$ (3.88 ms)				
0	0	1	$2^{11}/f_{RL}$ (7.76 ms)				
0	1	0	$2^{12}/f_{RL}$ (15.52 ms)				
0	1	1	$2^{13}/f_{RL}$ (31.03 ms)				
1	0	0	$2^{14}/f_{RL}$ (62.06 ms)				
1	0	1	$2^{15}/f_{RL}$ (124.12 ms)				
1	1	0	$2^{16}/f_{RL}$ (248.24 ms)				
1	1	1	$2^{17}/f_{RL}$ (496.48 ms)				
LSROSC	Internal low-speed oscillator operation						
0	Can be stopped by software (stopped when 1 is written to bit 0 (LSRSTOP) of RCM register)						
1	Cannot be stopped (not stopped even if 1 is written to LSRSTOP bit)						

Note Set a value that is the same as that of 0080H to 1080H because 0080H and 1080H are switched during the boot swap operation.

- Cautions**
1. The combination of **WDCS2 = WDCS1 = WDCS0 = 0** and **WINDOW1 = WINDOW0 = 0** is prohibited.
 2. The watchdog timer continues its operation during self-programming and EEPROM emulation of the flash memory. During processing, the interrupt acknowledge time is delayed. Set the overflow time and window size taking this delay into consideration.
 3. If **LSROSC = 0** (oscillation can be stopped by software), the count clock is not supplied to the watchdog timer in the **HALT** and **STOP** modes, regardless of the setting of bit 0 (**LSRSTOP**) of the internal oscillation mode register (**RCM**).
When 8-bit timer H1 operates with the internal low-speed oscillation clock, the count clock is supplied to 8-bit timer H1 even in the **HALT/STOP** mode.
 4. Be sure to clear bit 7 to 0.

- Remarks**
1. f_{RL} : Internal low-speed oscillation clock frequency
 2. (): $f_{RL} = 264$ kHz (MAX.)

Figure 20-1. Format of Option Byte (2/2)

Address: 0081H/1081H^{Notes 1, 2}

7	6	5	4	3	2	1	0
0	0	0	0	0	0	0	POCMODE

POCMODE	POC mode selection
0	1.59 V POC mode (default)
1	2.7 V/1.59 V POC mode

- Notes**
1. POCMODE can only be written by using a dedicated flash memory programmer. It cannot be set during self-programming or boot swap operation during self-programming (at this time, 1.59 V POC mode (default) is set). However, because the value of 1081H is copied to 0081H during the boot swap operation, it is recommended to set a value that is the same as that of 0081H to 1081H when the boot swap function is used.
 2. To change the setting for the POC mode, set the value to 0081H again after batch erasure (chip erasure) of the flash memory. The setting cannot be changed after the memory of the specified block is erased.

Caution Be sure to clear bits 7 to 1 to 0.

Address: 0082H/1082H, 0083H/1083H^{Note}

7	6	5	4	3	2	1	0
0	0	0	0	0	0	0	0

Note Be sure to set 00H to 0082H and 0083H, as these addresses are reserved areas. Also set 00H to 1082 and 1083H because 0082H and 0083H are switched with 1082H and 1083H when the boot swap operation is used.

Address: 0084H/1084H^{Notes 1, 2}

7	6	5	4	3	2	1	0
0	0	0	0	0	0	OCDEN1	OCDEN0

OCDEN1	OCDEN0	On-chip debug operation control
0	0	Operation disabled
0	1	Setting prohibited
1	0	Operation enabled. Does not erase data of the flash memory in case authentication of the on-chip debug security ID fails.
1	1	Operation enabled. Erases data of the flash memory in case authentication of the on-chip debug security ID fails.

- Notes**
1. Be sure to set 00H (on-chip debug operation disabled) to 0084H for products not equipped with the on-chip debug function (μ PD78F0500, 78F0501, 78F0502, and 78F0503). Also set 00H to 1084H because 0084H and 1084H are switched at boot swapping.
 2. To use the on-chip debug function with a product equipped with the on-chip debug function (μ PD78F0503D), set 02H or 03H to 0084H. Set a value that is the same as that of 0084H to 1084H because 0084H and 1084H are switched at boot swapping.

Remark For the on-chip debug security ID, see **CHAPTER 22 ON-CHIP DEBUG FUNCTION (μ PD78F0503D ONLY)**.

Here is an example of description of the software for setting the option bytes.

OPT	CSEG	AT 0080H	
OPTION:	DB	30H	; Enables watchdog timer operation (illegal access detection operation), ; Window open period of watchdog timer: 50%, ; Overflow time of watchdog timer: $2^{10}/f_{RL}$, ; Internal low-speed oscillator can be stopped by software.
	DB	00H	; 1.59 V POC mode
	DB	00H	; Reserved area
	DB	00H	; Reserved area
	DB	00H	; On-chip debug operation disabled

Remark Referencing of the option byte is performed during reset processing. For the reset processing timing, see **CHAPTER 17 RESET FUNCTION**.

CHAPTER 21 FLASH MEMORY

The 78K0/KB2 incorporates the flash memory to which a program can be written, erased, and overwritten while mounted on the board.

21.1 Internal Memory Size Switching Register

The internal memory capacity can be selected using the internal memory size switching register (IMS). IMS is set by an 8-bit memory manipulation instruction. Reset signal generation sets IMS to CFH.

Caution Be sure to set each product to the values shown in Table 21-1 after a reset release.

Figure 21-1. Format of Internal Memory Size Switching Register (IMS)

Address: FFF0H After reset: CFH R/W

Symbol	7	6	5	4	3	2	1	0
IMS	RAM2	RAM1	RAM0	0	ROM3	ROM2	ROM1	ROM0

RAM2	RAM1	RAM0	Internal high-speed RAM capacity selection
0	0	0	768 bytes
0	1	0	512 bytes
1	1	0	1024 bytes
Other than above			Setting prohibited

ROM3	ROM2	ROM1	ROM0	Internal ROM capacity selection
0	0	1	0	8 KB
0	1	0	0	16 KB
0	1	1	0	24 KB
1	0	0	0	32 KB
Other than above				Setting prohibited

Table 21-1. Internal Memory Size Switching Register Settings

Flash Memory Versions (78K0/KB2)	IMS Setting
μPD78F0500	42H
μPD78F0501	04H
μPD78F0502	C6H
μPD78F0503, 78F0503D	C8H

21.2 Writing with Flash Memory Programmer

Data can be written to the flash memory on-board or off-board, by using a dedicated flash memory programmer.

(1) On-board programming

The contents of the flash memory can be rewritten after the 78K0/KB2 has been mounted on the target system. The connectors that connect the dedicated flash memory programmer must be mounted on the target system.

(2) Off-board programming

Data can be written to the flash memory with a dedicated program adapter (FA series) before the 78K0/KB2 is mounted on the target system.

Remark The FA series is a product of Naito Densai Machida Mfg. Co., Ltd.

Table 21-2. Wiring Between 78K0/KB2 (30-pin Plastic SSOP (MC-5A4 and MC-CAB Types)) and Dedicated Flash Memory Programmer

Pin Configuration of Dedicated Flash Memory Programmer			With CSI10		With UART6	
Signal Name	I/O	Pin Function	Pin Name	Pin No.	Pin Name	Pin No.
SI/RxD	Input	Receive signal	SO10/P12	24	TxD6/P13	23
SO/TxD	Output	Transmit signal	SI10/RxD0/P11	25	RxD6/P14	22
SCK	Output	Transfer clock	SCK10/TxD0/P10	26	–	–
CLK	Output	Clock to 78K0/KB2	– ^{Note 1}	–	Note 2	Note 2
/RESET	Output	Reset signal	RESET	6	RESET	6
FLMD0	Output	Mode signal	FLMD0	7	FLMD0	7
V _{DD}	I/O	V _{DD} voltage generation/ power monitoring	V _{DD}	12	V _{DD}	12
			AV _{REF}	27	AV _{REF}	27
GND	–	Ground	V _{SS}	11	V _{SS}	11
			AV _{SS}	28	AV _{SS}	28

Notes 1. Only the internal high-speed oscillation clock (f_{RH}) can be used when CSI10 is used.

2. Only the X1 clock (f_x) or external main system clock (f_{EXCLK}) can be used when UART6 is used. When using the clock output of the dedicated flash memory programmer, pin connection varies depending on the type of the dedicated flash memory programmer used.

- PG-FP4, FL-PR4: Connect CLK of the programmer to EXCLK/X2/P122 (pin 8).
- PG-FPL3, FP-LITE3: Connect CLK of the programmer to X1/P121 (pin 9), and connect its inverted signal to X2/EXCLK/P122 (pin 8).

<R>

Examples of the recommended connection when using the adapter for flash memory writing are shown below.

Figure 21-2. Example of Wiring Adapter for Flash Memory Writing in 3-Wire Serial I/O (CSI10) Mode (30-pin Plastic SSOP (MC-5A4 and MC-CAB Types))

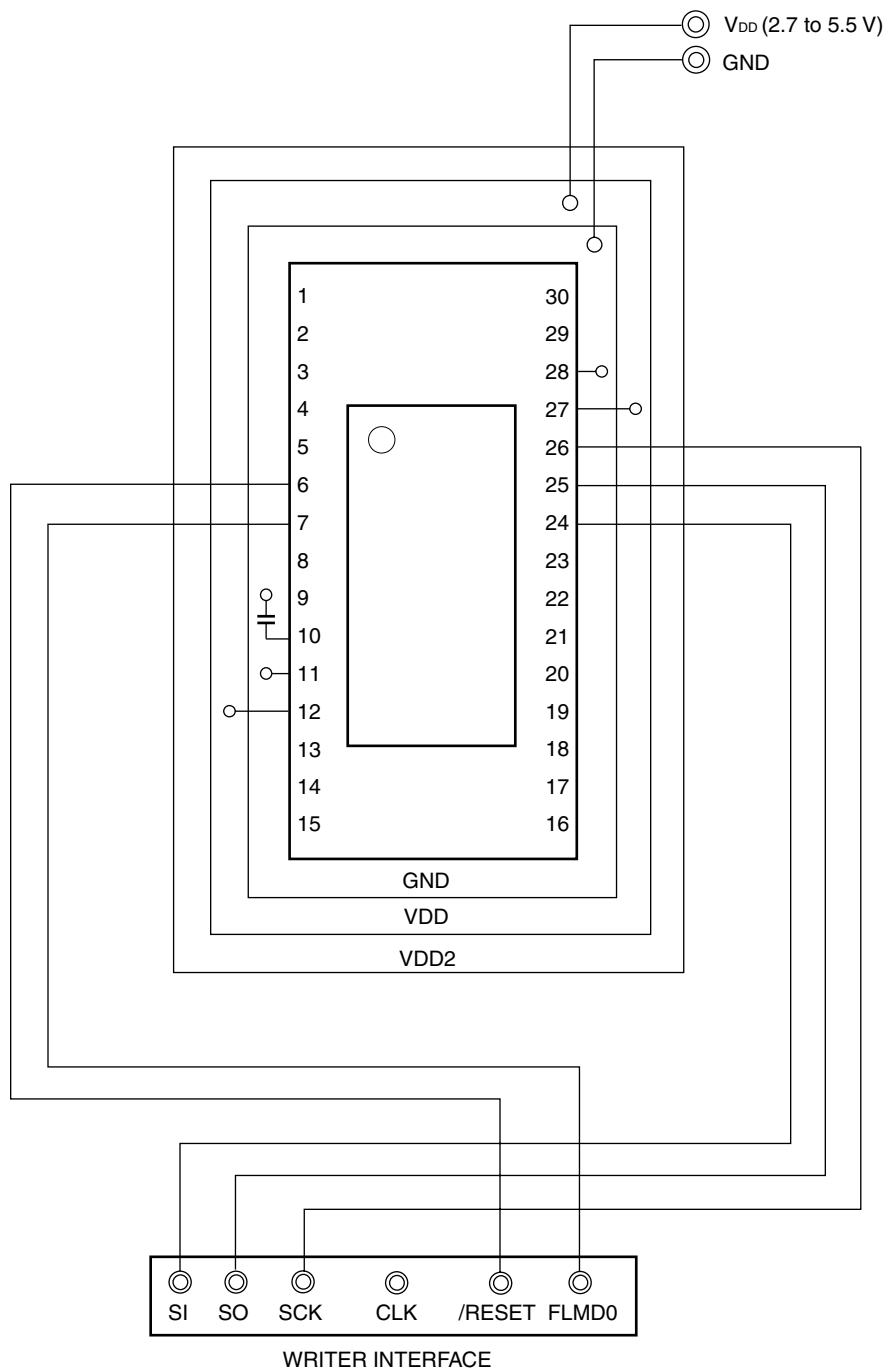

**Figure 21-3. Example of Wiring Adapter for Flash Memory Writing in UART (UART6) Mode
(30-pin Plastic SSOP (MC-5A4 and MC-CAB Types))**

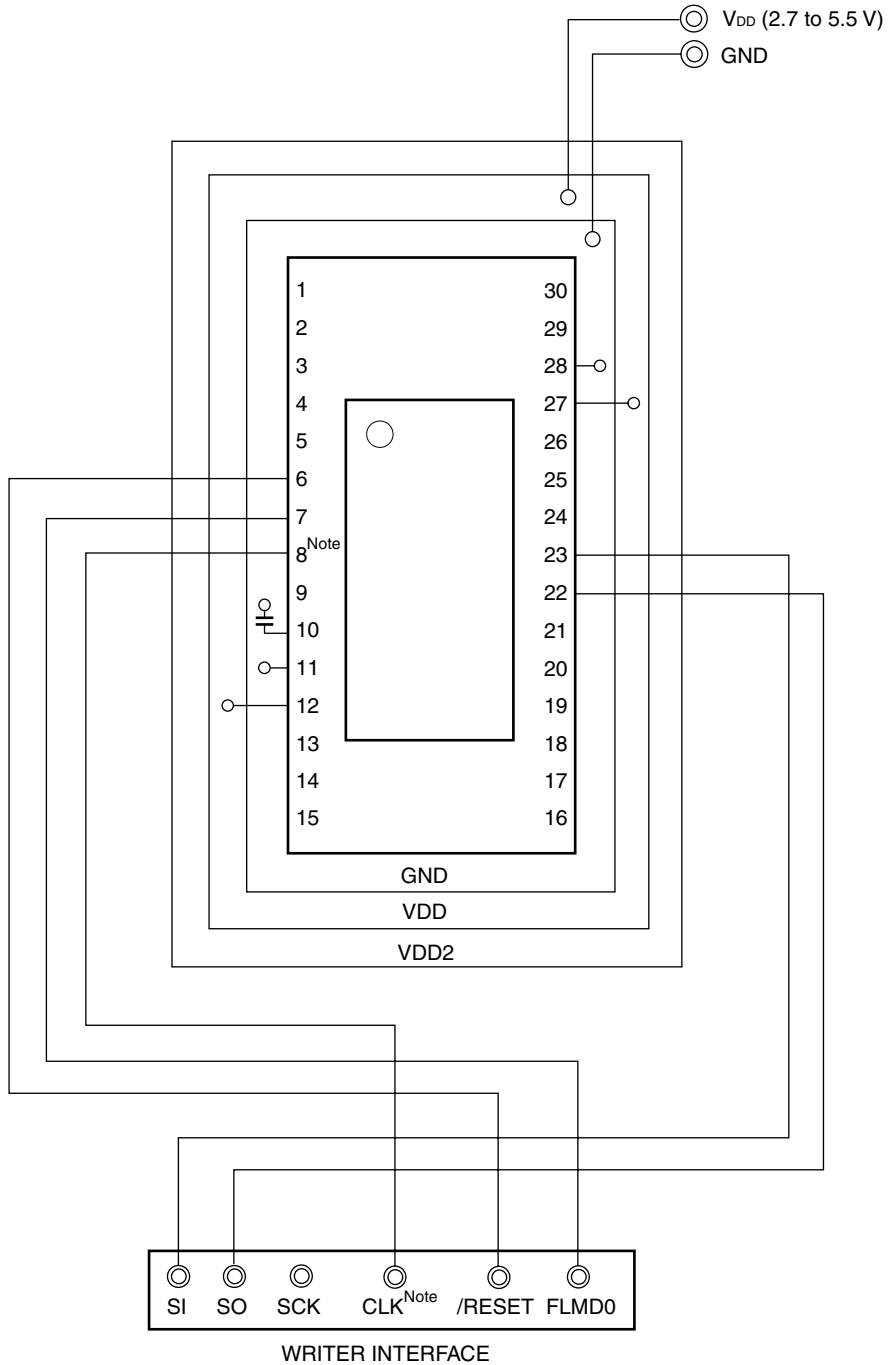

<R>

Note The above figure illustrates an example of wiring when using the clock output from the PG-FP4 or FL-PR4. When using the clock output from the PG-FPL3 or FP-LITE3, connect CLK to X1/P121 (pin 9), and connect its inverted signal to X2/EXCLK/P122 (pin 8).

21.3 Programming Environment

The environment required for writing a program to the flash memory of the 78K0/KB2 is illustrated below.

Figure 21-4. Environment for Writing Program to Flash Memory

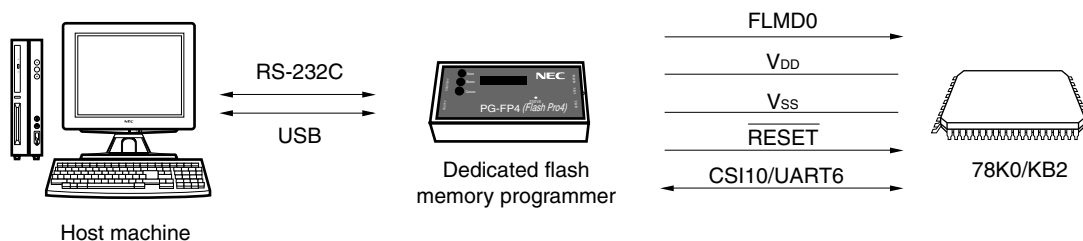

A host machine that controls the dedicated flash memory programmer is necessary.

To interface between the dedicated flash memory programmer and the 78K0/KB2, CSI10 or UART6 is used for manipulation such as writing and erasing. To write the flash memory off-board, a dedicated program adapter (FA series) is necessary.

21.4 Communication Mode

Communication between the dedicated flash memory programmer and the 78K0/KB2 is established by serial communication via CSI10 or UART6 of the 78K0/KB2.

(1) CSI10

Transfer rate: 2.4 kHz to 2.5 MHz

Figure 21-5. Communication with Dedicated Flash Memory Programmer (CSI10)

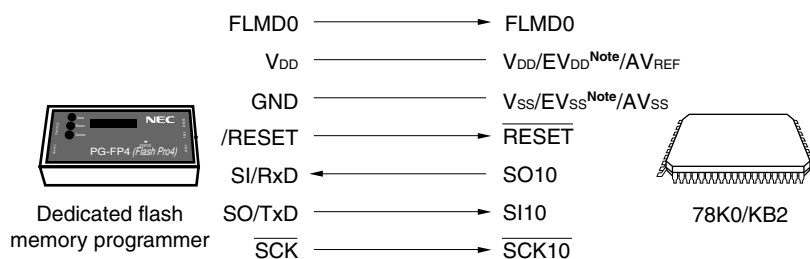

Note 36-pin plastic FLGA (FC-AA3 type) only

(2) UART6

Transfer rate: 115200 bps

Figure 21-6. Communication with Dedicated Flash Memory Programmer (UART6)

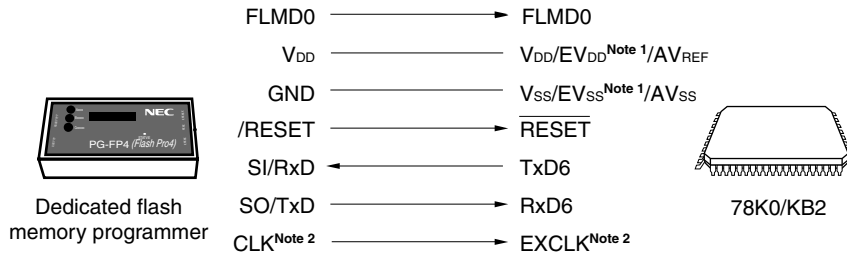

Notes 1. 36-pin plastic FLGA (FC-AA3 type) only.

2. The above figure illustrates an example of wiring when using the clock output from the PG-FP4 or FL-PR4.

When using the clock output from the PG-FPL3 or FP-LITE3, connect CLK to X1/P121, and connect its inverted signal to X2/EXCLK/P122.

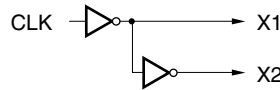

The dedicated flash memory programmer generates the following signals for the 78K0/KB2. For details, refer to the user's manual for the PG-FP4, FL-PR4, PG-FPL3, or FP-LITE3.

Table 21-3. Pin Connection

Dedicated Flash Memory Programmer			78K0/KB2	Connection	
Signal Name	I/O	Pin Function	Pin Name	CSI10	UART6
FLMD0	Output	Mode signal	FLMD0	○	○
V _{DD}	I/O	V _{DD} voltage generation/power monitoring	V _{DD} , EV _{DD} ^{Note 1} , AV _{REF}	○	○
GND	—	Ground	V _{SS} , EV _{SS} ^{Note 1} , AV _{SS}	○	○
CLK	Output	Clock output to 78K0/KB2	Note 2	× ^{Note 3}	○ ^{Note 2}
/RESET	Output	Reset signal	$\overline{\text{RESET}}$	○	○
SI/RxD	Input	Receive signal	SO10/TxD6	○	○
SO/TxD	Output	Transmit signal	SI10/RxD6	○	○
SCK	Output	Transfer clock	$\overline{\text{SCK10}}$	○	×

Notes 1. 36-pin plastic FLGA (FC-AA3 type) only.

2. Only the X1 clock (f_X) or external main system clock (f_{EXCLK}) can be used when UART6 is used. When using the clock output of the dedicated flash memory programmer, pin connection varies depending on the type of the dedicated flash memory programmer used.

- PG-FP4, FL-PR4: Connect CLK of the programmer to EXCLK/X2/P122.
- PG-FPL3, FP-LITE3: Connect CLK of the programmer to X1/P121, and connect its inverted signal to X2/EXCLK/P122.

3. Only the internal high-speed oscillation clock (f_{RH}) can be used when CSI10 is used.

(Remark on next page)

- Remark** ○: Be sure to connect the pin.
 ○: The pin does not have to be connected if the signal is generated on the target board.
 ×: The pin does not have to be connected.

21.5 Handling of Pins on Board

To write the flash memory on-board, connectors that connect the dedicated flash memory programmer must be provided on the target system. First provide a function that selects the normal operation mode or flash memory programming mode on the board.

When the flash memory programming mode is set, all the pins not used for programming the flash memory are in the same status as immediately after reset. Therefore, if the external device does not recognize the state immediately after reset, the pins must be handled as described below.

21.5.1 FLMD0 pin

In the normal operation mode, 0 V is input to the FLMD0 pin. In the flash memory programming mode, the V_{DD} write voltage is supplied to the FLMD0 pin. An FLMD0 pin connection example is shown below.

<R>

Figure 21-7. FLMD0 Pin Connection Example

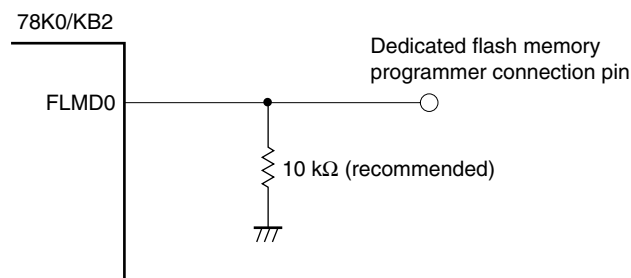

21.5.2 Serial interface pins

The pins used by each serial interface are listed below.

Table 21-4. Pins Used by Each Serial Interface

Serial Interface	Pins Used
CSI10	SO10, SI10, SCK10
UART6	TxD6, RxD6

To connect the dedicated flash memory programmer to the pins of a serial interface that is connected to another device on the board, care must be exercised so that signals do not collide or that the other device does not malfunction.

(1) Signal collision

If the dedicated flash memory programmer (output) is connected to a pin (input) of a serial interface connected to another device (output), signal collision takes place. To avoid this collision, either isolate the connection with the other device, or make the other device go into an output high-impedance state.

Figure 21-8. Signal Collision (Input Pin of Serial Interface)

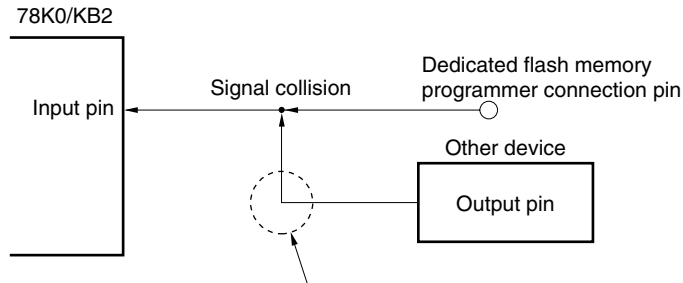

In the flash memory programming mode, the signal output by the device collides with the signal sent from the dedicated flash memory programmer. Therefore, isolate the signal of the other device.

(2) Malfunction of other device

If the dedicated flash memory programmer (output or input) is connected to a pin (input or output) of a serial interface connected to another device (input), a signal may be output to the other device, causing the device to malfunction. To avoid this malfunction, isolate the connection with the other device.

Figure 21-9. Malfunction of Other Device

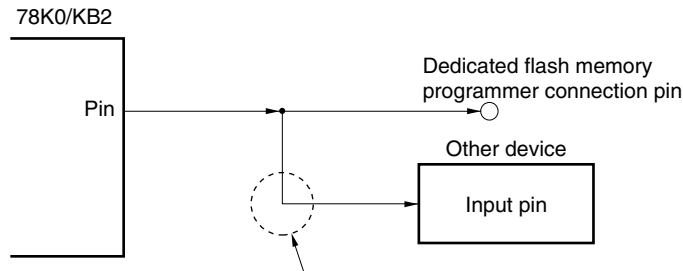

If the signal output by the 78K0/KB2 in the flash memory programming mode affects the other device, isolate the signal of the other device.

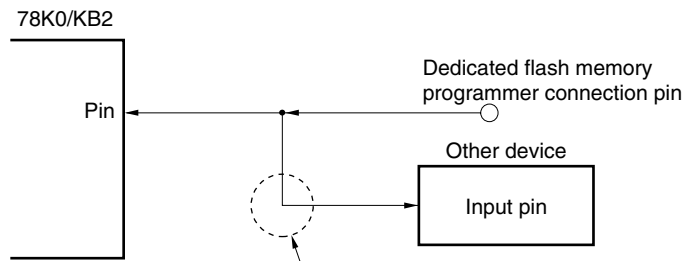

If the signal output by the dedicated flash memory programmer in the flash memory programming mode affects the other device, isolate the signal of the other device.

21.5.3 $\overline{\text{RESET}}$ pin

If the reset signal of the dedicated flash memory programmer is connected to the $\overline{\text{RESET}}$ pin that is connected to the reset signal generator on the board, signal collision takes place. To prevent this collision, isolate the connection with the reset signal generator.

If the reset signal is input from the user system while the flash memory programming mode is set, the flash memory will not be correctly programmed. Do not input any signal other than the reset signal of the dedicated flash memory programmer.

Figure 21-10. Signal Collision ($\overline{\text{RESET}}$ Pin)

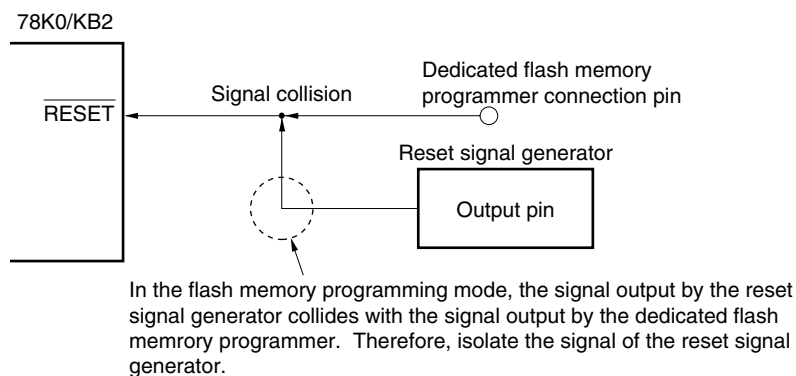

21.5.4 Port pins

When the flash memory programming mode is set, all the pins not used for flash memory programming enter the same status as that immediately after reset. If external devices connected to the ports do not recognize the port status immediately after reset, the port pin must be connected to V_{DD} or V_{SS} via a resistor.

21.5.5 REGC pin

Connect the REGC pin to GND via a capacitor (0.47 to 1 μF : recommended) in the same manner as during normal operation.

21.5.6 Other signal pins

Connect X1 and X2 in the same status as in the normal operation mode when using the on-board clock.

<R> To input the operating clock from the dedicated flash memory programmer, however, connect as follows.

- PG-FP4, FL-PR4: Connect CLK of the programmer to EXCLK/X2/P122.
- PG-FPL3, FP-LITE3: Connect CLK of the programmer and X1/P121, and connect its inverted signal to X2/EXCLK/P122.

- Cautions**
1. Only the internal high-speed oscillation clock (f_{RH}) can be used when CSI10 is used.
 2. Only the X1 clock (f_x) or external main system clock (f_{EXCLK}) can be used when UART6 is used.

<R> **Cautions 3.** For the product with an on-chip debug function (μ PD78F0503D), connect P31/INTP2/OCD1A^{Note} and P121/X1/OCD0A^{Note} as follows when writing the flash memory with a flash memory programmer.

- P31/INTP2/OCD1A^{Note}: Connect to V_{SS} via a resistor (10 k Ω : recommended).
- P121/X1/OCD0A^{Note}: When using this pin as a port, connect it to V_{SS} via a resistor (10 k Ω : recommended) (in the input mode) or leave it open (in the output mode).

The above connection is not necessary when writing the flash memory by means of self programming.

<R> **Note** OCD0A and OCD1A are provided to the μ PD78F0503D only.

21.5.7 Power supply

To use the supply voltage output of the flash memory programmer, connect the V_{DD} pin to V_{DD} of the flash memory programmer, and the V_{SS} pin to GND of the flash memory programmer.

To use the on-board supply voltage, connect in compliance with the normal operation mode.

<R> However, be sure to connect the V_{DD} and V_{SS} pins to V_{DD} and GND of the flash memory programmer to use the power monitor function with the flash memory programmer, even when using the on-board supply voltage.

Supply the same other power supplies (EV_{DD}^{Note}, EV_{SS}^{Note}, AV_{REF}, and AV_{SS}) as those in the normal operation mode.

Note 36-pin plastic FLGA (FC-AA3 type) only.

21.6 Programming Method

21.6.1 Controlling flash memory

The following figure illustrates the procedure to manipulate the flash memory.

Figure 21-11. Flash Memory Manipulation Procedure

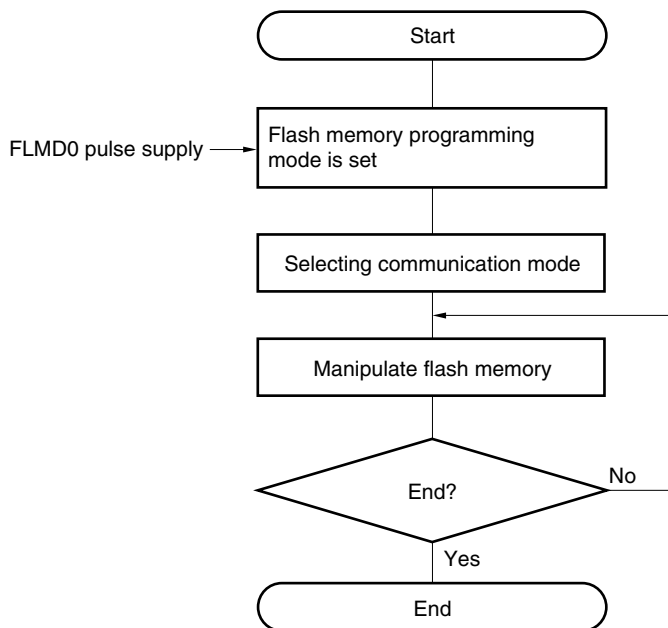

21.6.2 Flash memory programming mode

To rewrite the contents of the flash memory by using the dedicated flash memory programmer, set the 78K0/KB2 in the flash memory programming mode. To set the mode, set the FLMD0 pin to V_{DD} and clear the reset signal.

Change the mode by using a jumper when writing the flash memory on-board.

Figure 21-12. Flash Memory Programming Mode

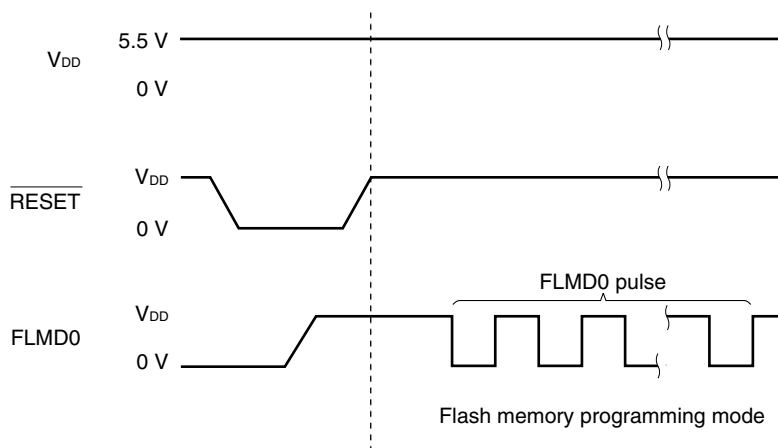

Table 21-5. Relationship Between FLMD0 Pin and Operation Mode After Reset Release

FLMD0	Operation Mode
0	Normal operation mode
V_{DD}	Flash memory programming mode

21.6.3 Selecting communication mode

In the 78K0/KB2, a communication mode is selected by inputting pulses (up to 11 pulses) to the FLMD0 pin after the dedicated flash memory programming mode is entered. These FLMD0 pulses are generated by the flash memory programmer.

The following table shows the relationship between the number of pulses and communication modes.

<R>

Table 21-6. Communication Modes

Communication Mode	Standard Setting ^{Note 1}					Pins Used	Peripheral Clock	Number of FLMD0 Pulses
	Port	Speed	On Target	Frequency	Multiply Rate			
UART (UART6)	UART-Ext-Osc	115200 bps ^{Note 3}	Optional	2 to 20 MHz ^{Note 2}	1.0	TxD6, RxD6	f _X	0
	UART-Ext-FP4CK						f _{EXCLK}	3
3-wire serial I/O (CSI10)	CSI-Internal-OSC	2.4 kHz to 2.5 MHz				SO10, SI10, SCK10	f _{RH}	8

- Notes**
1. Selection items for Standard settings on GUI of the flash memory programmer.
 2. The possible setting range differs depending on the voltage. For details, refer to the chapter of electrical specifications.
 3. Because factors other than the baud rate error, such as the signal waveform slew, also affect UART communication, thoroughly evaluate the slew as well as the baud rate error.

Caution When UART6 is selected, the receive clock is calculated based on the reset command sent from the dedicated flash memory programmer after the FLMD0 pulse has been received.

Remark

f_X: X1 clock
 f_{EXCLK}: External main system clock
 f_{RH}: Internal high-speed oscillation clock

21.6.4 Communication commands

The 78K0/KB2 communicates with the dedicated flash memory programmer by using commands. The signals sent from the flash memory programmer to the 78K0/KB2 are called commands, and the signals sent from the 78K0/KB2 to the dedicated flash memory programmer are called response.

Figure 21-13. Communication Commands

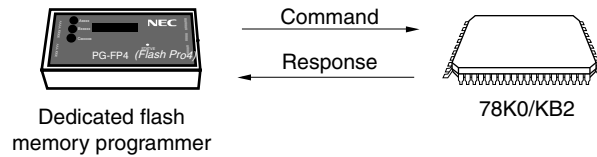

The flash memory control commands of the 78K0/KB2 are listed in the table below. All these commands are issued from the programmer and the 78K0/KB2 perform processing corresponding to the respective commands.

<R>

Table 21-7. Flash Memory Control Commands

Classification	Command Name	Function
Verify	Verify	Compares the contents of a specified area of the flash memory with data transmitted from the programmer.
Erase	Chip Erase	Erases the entire flash memory.
	Block Erase	Erases a specified area in the flash memory.
Blank check	Block Blank Check	Checks if a specified block in the flash memory has been correctly erased.
Write	Programming	Writes data to a specified area in the flash memory.
Getting information	Status	Gets the current operating status (status data).
	Silicon Signature	Gets 78K0/Kx2 information (such as the part number and flash memory configuration).
	Version Get	Gets the 78K0/Kx2 version and firmware version.
	Checksum	Gets the checksum data for a specified area.
Security	Security Set	Sets security information.
Others	Reset	Used to detect synchronization status of communication.
	Oscillating Frequency Set	Specifies an oscillation frequency.

The 78K0/KB2 return a response for the command issued by the dedicated flash memory programmer. The response names sent from the 78K0/KB2 are listed below.

Table 21-8. Response Names

Response Name	Function
ACK	Acknowledges command/data.
NAK	Acknowledges illegal command/data.

21.7 Security Settings

<R> The 78K0/KB2 supports a security function that prohibits rewriting the user program written to the internal flash memory, so that the program cannot be changed by an unauthorized person.

The operations shown below can be performed using the security set command. The security setting is valid when the programming mode is set next.

<R> • Disabling batch erase (chip erase)

Execution of the block erase and batch erase (chip erase) commands for entire blocks in the flash memory is prohibited by this setting during on-board/off-board programming. Once execution of the batch erase (chip erase) command is prohibited, all of the prohibition settings (including prohibition of batch erase (chip erase)) can no longer be cancelled.

Caution After the security setting for the batch erase is set, erasure cannot be performed for the device. In addition, even if a write command is executed, data different from that which has already been written to the flash memory cannot be written, because the erase command is disabled.

<R> • Disabling block erase

Execution of the block erase command for a specific block in the flash memory is prohibited during on-board/off-board programming. However, blocks can be erased by means of self programming.

<R> • Disabling write

Execution of the write and block erase commands for entire blocks in the flash memory is prohibited during on-board/off-board programming. However, blocks can be written by means of self programming.

• Disabling rewriting boot cluster 0

Execution of the batch erase (chip erase) command, block erase command, and write command on boot cluster 0 (0000H to 0FFFH) in the flash memory is prohibited by this setting.

Caution If a security setting that rewrites boot cluster 0 has been applied, boot cluster 0 of that device will not be rewritten.

<R> The batch erase (chip erase), block erase, write commands, and rewriting boot cluster 0 are enabled by the default setting when the flash memory is shipped. Security can be set by on-board/off-board programming and self programming. Each security setting can be used in combination.

Prohibition of erasing blocks and writing is cleared by executing the batch erase (chip erase) command.

Table 21-9 shows the relationship between the erase and write commands when the 78K0/KB2 security function is enabled.

<R>

Table 21-9. Relationship Between Enabling Security Function and Command**(1) During on-board/off-board programming**

Valid Security	Executed Command		
	Batch Erase (Chip Erase)	Block Erase	Write
Prohibition of batch erase (chip erase)	Cannot be erased in batch	Blocks cannot be erased.	Can be performed ^{Note} .
Prohibition of block erase	Can be erased in batch.		Can be performed.
Prohibition of writing			Cannot be performed.
Prohibition of rewriting boot cluster 0	Cannot be erased in batch	Boot cluster 0 cannot be erased.	Boot cluster 0 cannot be written.

Note Confirm that no data has been written to the write area. Because data cannot be erased after batch erase (chip erase) is prohibited, do not write data if the data has not been erased.

(2) During self programming

Valid Security	Executed Command	
	Block Erase	Write
Prohibition of batch erase (chip erase)	Blocks can be erased.	Can be performed.
Prohibition of block erase		
Prohibition of writing		
Prohibition of rewriting boot cluster 0	Boot cluster 0 cannot be erased.	Boot cluster 0 cannot be written.

Table 21-10 shows how to perform security settings in each programming mode.

<R>

Table 21-10. Setting Security in Each Programming Mode**(1) On-board/off-board programming**

Security	Security Setting	How to Disable Security Setting
Prohibition of batch erase (chip erase)	Set via GUI of dedicated flash memory programmer, etc.	Cannot be disabled after set.
Prohibition of block erase		Execute batch erase (chip erase) command
Prohibition of writing		
Prohibition of rewriting boot cluster 0		Cannot be disabled after set.

(2) Self programming

Security	Security Setting	How to Disable Security Setting
Prohibition of batch erase (chip erase)	Set by using information library.	Cannot be disabled after set.
Prohibition of block erase		Execute batch erase (chip erase) command during on-board/off-board programming (cannot be disabled during self programming)
Prohibition of writing		
Prohibition of rewriting boot cluster 0		Cannot be disabled after set.

<R>

21.8 Processing Time for Each Command When PG-FP4 Is Used (Reference)

The following table shows the processing time for each command (reference) when the PG-FP4 is used as a dedicated flash memory programmer.

Table 21-11. Processing Time for Each Command When PG-FP4 Is Used (Reference)

- **μPD78F0503, 78F0503D (internal ROM capacity: 32 KB)**

Command of PG-FP4	Port: CSI-Internal-OSC (Internal high-speed oscillation clock (f_{RH})), Speed: 2.5 MHz	Port: UART-Ext-FP4CK (External main system clock (f_{EXCLK})), Speed: 115,200 bps	
		Frequency: 2.0 MHz	Frequency: 20 MHz
Signature	0.5 s (TYP.)	0.5 s (TYP.)	0.5 s (TYP.)
Blankcheck	0.5 s (TYP.)	0.5 s (TYP.)	0.5 s (TYP.)
Erase	0.5 s (TYP.)	0.5 s (TYP.)	0.5 s (TYP.)
Program	2.5 s (TYP.)	5 s (TYP.)	5 s (TYP.)
Verify	1.5 s (TYP.)	4 s (TYP.)	3.5 s (TYP.)
E.P.V	3.5 s (TYP.)	6 s (TYP.)	6 s (TYP.)
Checksum	0.5 s (TYP.)	0.5 s (TYP.)	0.5 s (TYP.)
Security	0.5 s (TYP.)	0.5 s (TYP.)	0.5 s (TYP.)

21.9 Flash Memory Programming by Self-Programming

The 78K0/KB2 supports a self-programming function that can be used to rewrite the flash memory via a user program. Because this function allows a user application to rewrite the flash memory by using the 78K0/KB2 self-programming library, it can be used to upgrade the program in the field.

If an interrupt occurs during self-programming, self-programming can be temporarily stopped and interrupt servicing can be executed. To execute interrupt servicing, restore the normal operation mode after self-programming has been stopped, and execute the EI instruction. After the self-programming mode is later restored, self-programming can be resumed.

Remark For details of the self-programming function and the 78K0/KB2 self-programming library, refer to **78K0/Kx2 Flash Memory Self Programming User's Manual (U17516E)**.

- Cautions**
1. Input a high level to the FLMD0 pin during self-programming.
 2. Be sure to execute the DI instruction before starting self-programming.
The self-programming function checks the interrupt request flags (IF0L, IF0H, IF1L, and IF1H). If an interrupt request is generated, self-programming is stopped.
 3. Self-programming is also stopped by an interrupt request that is not masked even in the DI status. To prevent this, mask the interrupt by using the interrupt mask flag registers (MK0L, MK0H, MK1L, and MK1H).

The following figure illustrates a flow of rewriting the flash memory by using a self programming sample library.

<R>

Figure 21-14. Flow of Self Programming (Rewriting Flash Memory)

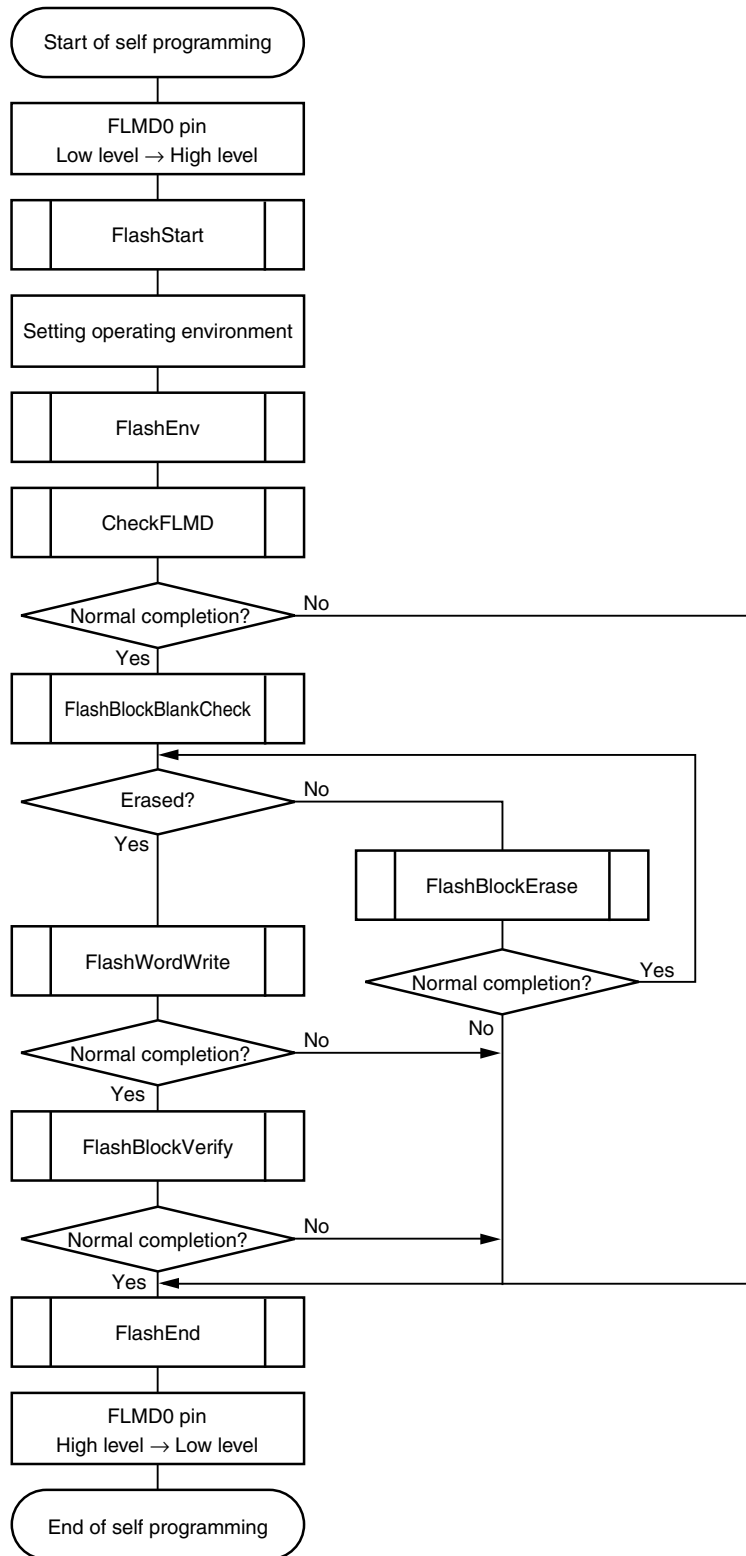

Remark For details of the self programming sample library, refer to 78K0/Kx2 Flash Memory Self Programming User's Manual (U17516E).

The following table shows the processing time and interrupt response time for the self programming sample library.

<R> **Table 21-12. Processing Time and Interrupt Response Time for Self Programming Sample Library (1/4)**

(1) When internal high-speed oscillation clock is used and entry RAM is located outside short direct addressing range

Library Name	Processing Time (μ s)				Interrupt Response Time (μ s)	
	Normal Model of C Compiler		Static Model of C Compiler/Assembler		Min.	Max.
	Min.	Max.	Min.	Max.		
Self programming start library	4.25				-	-
Initialize library	977.75				-	-
Mode check library	753.875		753.125		-	-
Block blank check library	12770.875		12765.875		391.25	1300.5
Block erase library	36909.5	356318	36904.5	356296.25	389.25	1393.5
Word write library	1214 (1214.375)	2409 (2409.375)	1207 (1207.375)	2402 (2402.375)	394.75	1289.5
Program verify library	25618.875		25613.875		390.25	1324.5
Self programming end library	4.25				-	-
Get information library (option value: 03H)	871.25 (871.375)		866 (866.125)		-	-
Get information library (option value: 04H)	863.375 (863.5)		858.125 (858.25)		-	-
Get information library (option value: 05H)	1024.75 (1043.625)		1037.5 (1038.375)		-	-
Set information library	105524.75	790809.375	105523.75	790808.375	387	852.5
EEPROM write library	1496.5 (1496.875)	2691.5 (2691.875)	1489.5 (1489.875)	2684.5 (2684.875)	399.75	1395.5

Remark The value in the parentheses indicates the value when a write start address structure is located at a place other than the internal high-speed RAM.

<R> Table 21-12. Processing Time and Interrupt Response Time for Self Programming Sample Library (2/4)

(2) When internal high-speed oscillation clock is used and entry RAM is located in short direct addressing range (FE20H)

Library Name	Processing Time (μ s)				Interrupt Response Time (μ s)	
	Normal Model of C Compiler		Static Model of C Compiler/Assembler			
	Min.	Max.	Min.	Max.	Min.	Max.
Self programming start library	4.25				–	–
Initialize library	443.5				–	–
Mode check library	219.625		218.875		–	–
Block blank check library	12236.625		12231.625		81.25	727.5
Block erase library	36363.25	355771.75	36358.25	355750	79.25	820.5
Word write library	679.75 (680.125)	1874.75 (1875.125)	672.75 (673.125)	1867.75 (1868.125)	84.75	716.5
Program verify library	25072.625		25067.625		80.25	751.5
Self programming end library	4.25				–	–
Get information library (option value: 03H)	337 (337.125)		331.75 (331.875)		–	–
Get information library (option value: 04H)	329.125 (239.25)		323.875 (324)		–	–
Get information library (option value: 05H)	502.25 (503.125)		497 (497.875)		–	–
Set information library	104978.5	541143.125	104977.5	541142.125	77	279.5
EEPROM write library	962.25 (962.625)	2157.25 (2157.625)	955.25 (955.625)	2150.25 (2150.625)	89.75	822.5

Remark The value in the parentheses indicates the value when a write start address structure is located at a place other than the internal high-speed RAM.

<R> Table 21-12. Processing Time and Interrupt Response Time for Self Programming Sample Library (3/4)

(3) When high-speed system clock (X1 oscillation or external clock input) is used and entry RAM is located outside short direct addressing range

Library Name	Processing Time (μs)				Interrupt Response Time (μs)	
	Normal Model of C Compiler		Static Model of C Compiler/Assembler			
	Min.	Max.	Min.	Max.	Min.	Max.
Self programming start library	34/f _{XH}				–	–
Initialize library	49/f _{XH} + 485.8125				–	–
Mode check library	35/f _{XH} + 374.75		29/f _{XH} + 374.75		–	–
Block blank check library	174/f _{XH} + 6382.0625		134/f _{XH} + 6382.0625		18/f _{XH} + 192	28/f _{XH} + 698
Block erase library	174/f _{XH} + 31093.875	174/f _{XH} + 298948.125	134/f _{XH} + 31093.875	134/f _{XH} + 298948.125	18/f _{XH} + 186	28/f _{XH} + 745
Word write library	318 (321)/f _{XH} + 644.125	318 (321)/f _{XH} + 1491.625	262 (265)/f _{XH} + 644.125	262 (265)/f _{XH} + 1491.625	22/f _{XH} + 189	28/f _{XH} + 693
Program verify library	174/f _{XH} + 13448.5625		134/f _{XH} + 13448.5625		18/f _{XH} + 192	28/f _{XH} + 709
Self programming end library	34/f _{XH}				–	–
Get information library (option value: 03H)	171 (172)/f _{XH} + 432.4375		129 (130)/f _{XH} + 432.4375		–	–
Get information library (option value: 04H)	181 (182)/f _{XH} + 427.875		139 (140)/f _{XH} + 427.875		–	–
Get information library (option value: 05H)	404 (411)/f _{XH} + 496.125		362 (369)/f _{XH} + 496.125		–	–
Set information library	75/f _{XH} + 79157.6875	75/f _{XH} + 652400	67/f _{XH} + 79157.6875	67/f _{XH} + 652400	16/f _{XH} + 190	28/f _{XH} + 454
EEPROM write library	318 (321)/f _{XH} + 799.875	318 (321)/f _{XH} + 1647.375	262 (265)/f _{XH} + 799.875	262 (265)/f _{XH} + 1647.375	22/f _{XH} + 191	28/f _{XH} + 783

- Remarks**
1. The value in the parentheses indicates the value when a write start address structure is located at a place other than the internal high-speed RAM.
 2. f_{XH}: High-speed system clock frequency

<R> **Table 21-12. Processing Time and Interrupt Response Time for Self Programming Sample Library (4/4)**

(4) When high-speed system clock (X1 oscillation or external clock input) is used and entry RAM is located in short direct addressing range (FE20H)

Library Name	Processing Time (μs)				Interrupt Response Time (μs)	
	Normal Model of C Compiler		Static Model of C Compiler/Assembler			
	Min.	Max.	Min.	Max.	Min.	Max.
Self programming start library	34/f _{XH}				–	–
Initialize library	49/f _{XH} + 224.6875				–	–
Mode check library	35/f _{XH} + 113.625		29/f _{XH} + 113.625		–	–
Block blank check library	174/f _{XH} + 6120.9375		134/f _{XH} + 6120.9375		18/f _{XH} + 55	28/f _{XH} + 462
Block erase library	174/f _{XH} + 30820.75	174/f _{XH} + 298675	134/f _{XH} + 30820.75	134/f _{XH} + 298675	18/f _{XH} + 49	28/f _{XH} + 509
Word write library	318 (321)/f _{XH} + 383	318 (321)/f _{XH} + 1230.5	262 (265)/f _{XH} + 383	262 (265)/f _{XH} + 1230.5	22/f _{XH} + 52	28/f _{XH} + 457
Program verify library	174/f _{XH} + 13175.4375		134/f _{XH} + 13175.4375		18/f _{XH} + 55	28/f _{XH} + 473
Self programming end library	34/f _{XH}				–	–
Get information library (option value: 03H)	171 (172)/f _{XH} + 171.3125		129 (130)/f _{XH} + 171.3125		–	–
Get information library (option value: 04H)	181 (182)/f _{XH} + 166.75		139 (140)/f _{XH} + 166.75		–	–
Get information library (option value: 05H)	404 (411)/f _{XH} + 231.875		362 (369)/f _{XH} + 231.875		–	–
Set information library	75/f _{XH} + 78884.5625	75/f _{XH} + 527566.875	67/f _{XH} + 78884.5625	67/f _{XH} + 527566.875	16/f _{XH} + 53	28/f _{XH} + 218
EEPROM write library	318 (321)/f _{XH} + 538.75	318 (321)/f _{XH} + 1386.25	262 (265)/f _{XH} + 538.75	262 (265)/f _{XH} + 1386.25	22/f _{XH} + 54	28/f _{XH} + 547

Remarks 1. The value in the parentheses indicates the value when a write start address structure is located at a place other than the internal high-speed RAM.

2. f_{XH}: High-speed system clock frequency

21.9.1 Boot swap function

If rewriting the boot area has failed during self-programming due to a power failure or some other cause, the data in the boot area may be lost and the program may not be restarted by resetting.

The boot swap function is used to avoid this problem.

Before erasing boot cluster 0^{Note}, which is a boot program area, by self-programming, write a new boot program to boot cluster 1 in advance. When the program has been correctly written to boot cluster 1, swap this boot cluster 1 and boot cluster 0 by using the set information function of the firmware of the 78K0/KB2, so that boot cluster 1 is used as a boot area. After that, erase or write the original boot program area, boot cluster 0.

As a result, even if a power failure occurs while the boot programming area is being rewritten, the program is executed correctly because it is booted from boot cluster 1 to be swapped when the program is reset and started next.

If the program has been correctly written to boot cluster 0, restore the original boot area by using the set information function of the firmware of the 78K0/KB2.

Note A boot cluster is a 4 KB area and boot clusters 0 and 1 are swapped by the boot swap function.

Boot cluster 0 (0000H to 0FFFH): Original boot program area

Boot cluster 1 (1000H to 1FFFH): Area subject to boot swap function

<R>

Figure 21-15. Boot Swap Function

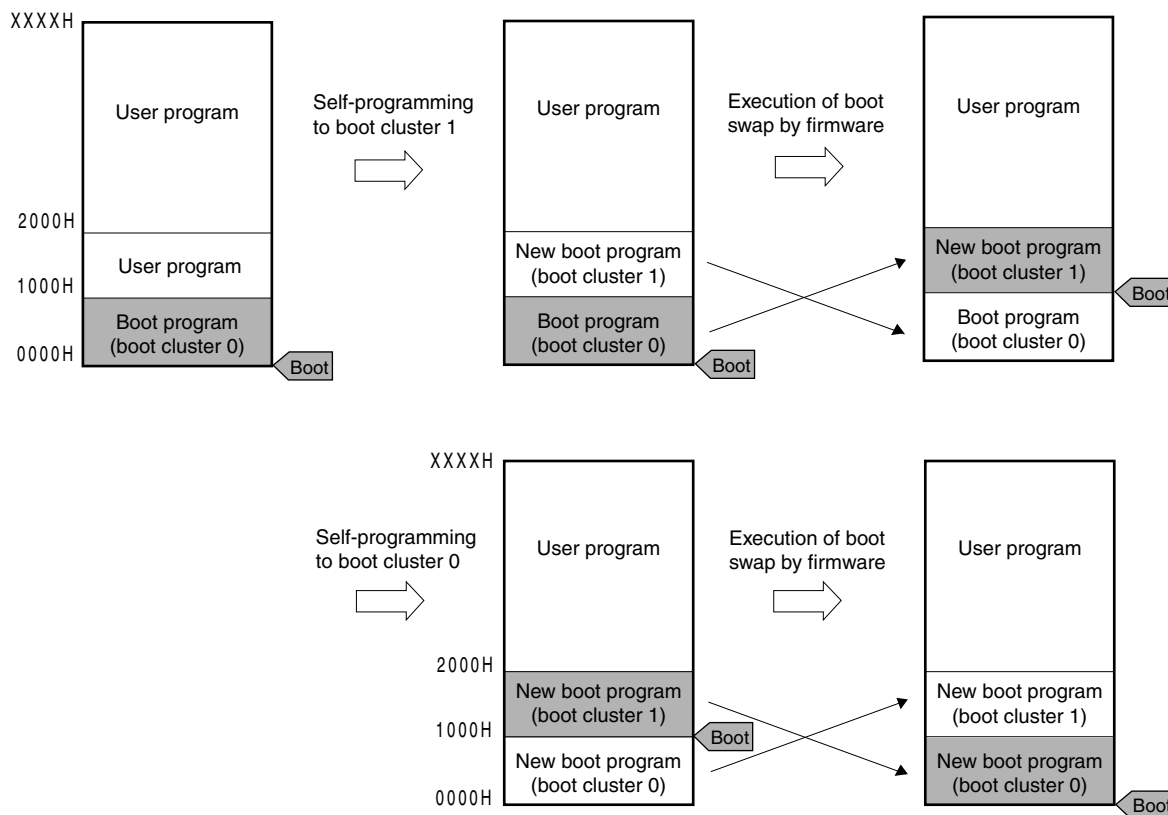
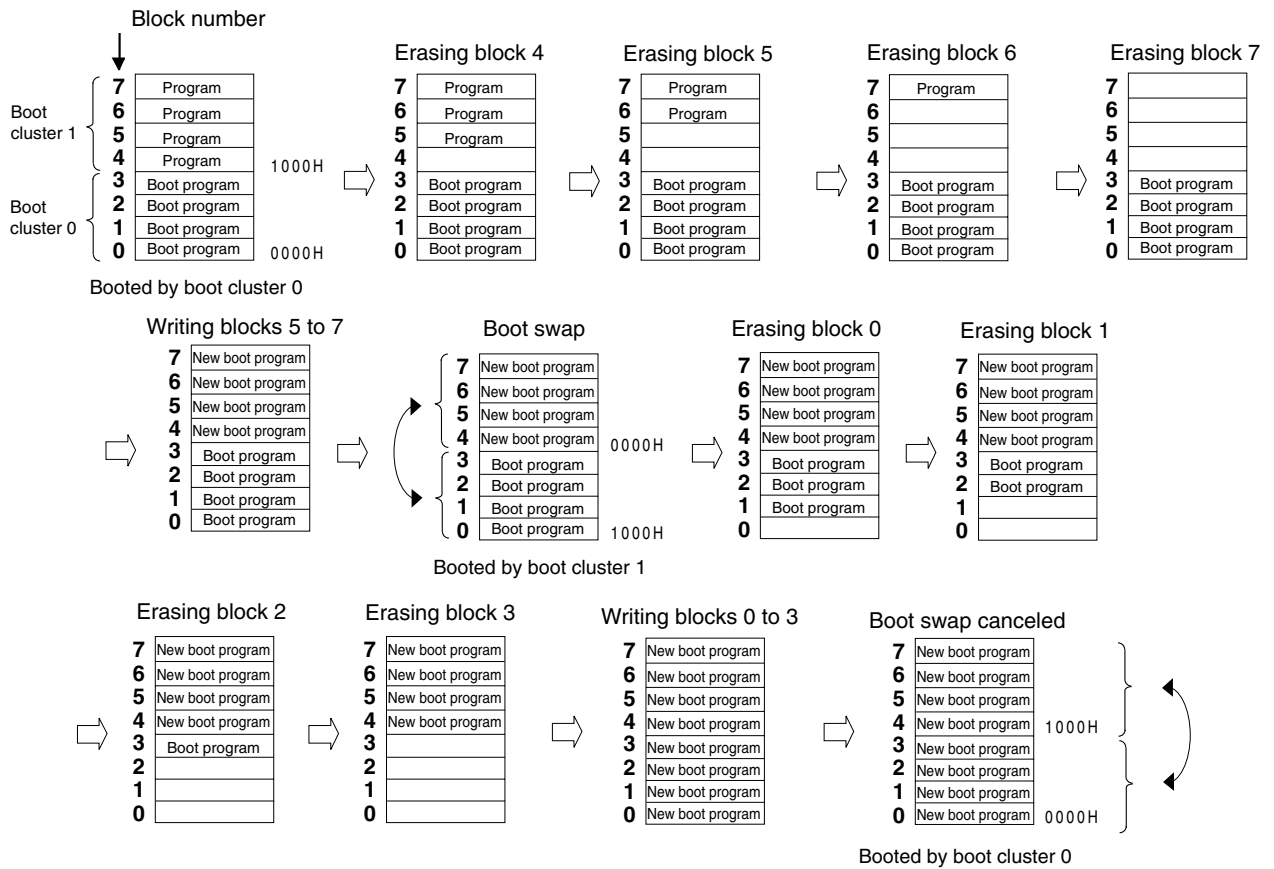

Figure 21-16. Example of Executing Boot Swapping



CHAPTER 22 ON-CHIP DEBUG FUNCTION (μ PD78F0503D ONLY)

22.1 Connecting QB-78K0MINI to μ PD78F0503D

The μ PD78F0503D uses the V_{DD} , FLMD0, $\overline{\text{RESET}}$, OCD0A/X1 (or OCD1A/P31), OCD0B/X2 (or OCD1B/P32), and V_{SS} pins to communicate with the host machine via an on-chip debug emulator (QB-78K0MINI). Whether OCD0A/X1 and OCD1A/P31, or OCD0B/X2 and OCD1B/P32 are used can be selected.

Caution The μ PD78F0503D has an on-chip debug function. Do not use this product for mass production because its reliability cannot be guaranteed after the on-chip debug function has been used, given the issue of the number of times the flash memory can be rewritten. NEC Electronics does not accept complaints concerning this product.

Figure 22-1. Connection Example of QB-78K0MINI and μ PD78F0503D
(When OCD0A/X1 and OCD0B/X2 Are Used)

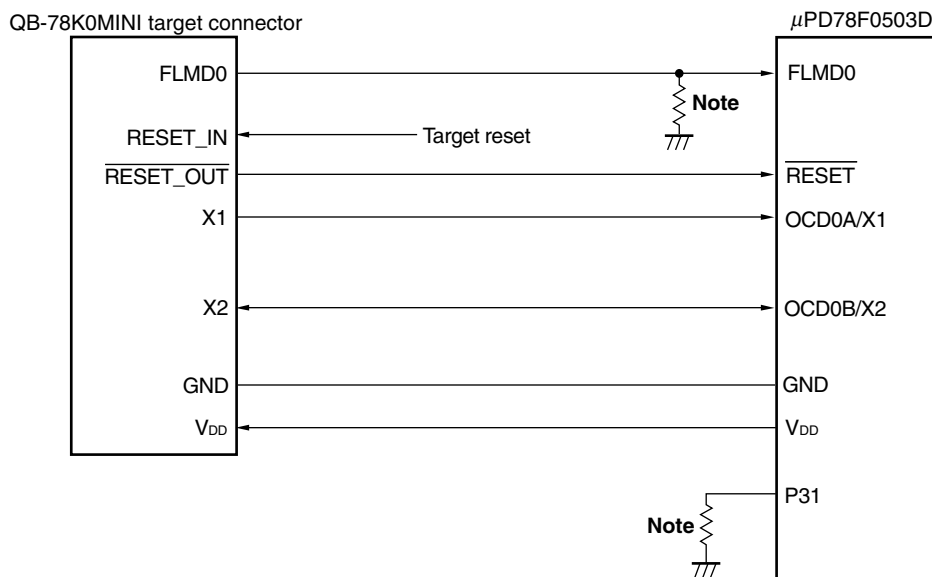

<R> **Note** Make pull-down resistor 470 Ω or more (10 k Ω : recommended).

- Cautions**
1. Input the clock from the OCD0A/X1 pin during on-chip debugging.
 2. Control the OCD0A/X1 and OCD0B/X2 pins by externally pulling down the OCD1A/P31 pin.

**Figure 22-2. Connection Example of QB-78K0MINI and μPD78F0503D
(When OCD1A/P31 and OCD1B/P32 Are Used)**

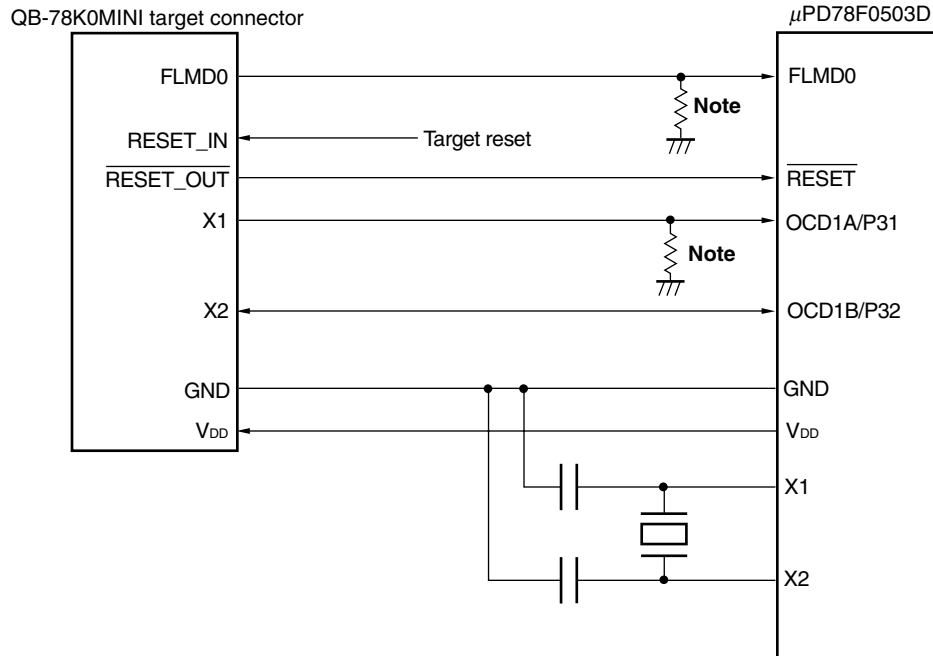

<R> **Note** Make pull-down resistor 470 Ω or more (10 kΩ: recommended).

Connect the FLMD0 pin as follows when performing self programming by means of on-chip debugging.

<R> **Figure 22-3. Connection of FLMD0 Pin for Self Programming by Means of On-Chip Debugging**

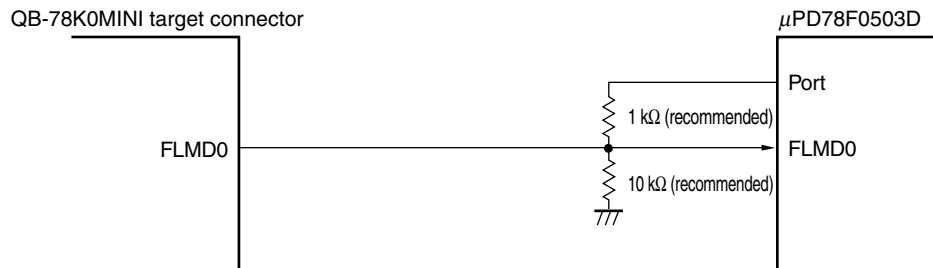

22.2 On-Chip Debug Security ID

The μ PD78F0503D has an on-chip debug operation control flag in the flash memory at 0084H (see **CHAPTER 20 OPTION BYTE**) and an on-chip debug security ID setting area at 0085H to 008EH.

When the boot swap function is used, also set a value that is the same as that of 1084H and 1085H to 108EH in advance, because 0084H, 0085H to 008EH and 1084H, and 1085H to 108EH are switched.

For details on the on-chip debug security ID, refer to the QB-78K0MINI User's Manual (U17029E).

Table 22-1. On-Chip Debug Security ID

Address	On-Chip Debug Security ID
0085H to 008EH	Any ID code of 10 bytes
1085H to 108EH	

CHAPTER 23 INSTRUCTION SET

This chapter lists each instruction set of the 78K0/KB2 in table form. For details of each operation and operation code, refer to the separate document **78K/0 Series Instructions User's Manual (U12326E)**.

23.1 Conventions Used in Operation List

23.1.1 Operand identifiers and specification methods

Operands are written in the "Operand" column of each instruction in accordance with the specification method of the instruction operand identifier (refer to the assembler specifications for details). When there are two or more methods, select one of them. Uppercase letters and the symbols #, !, \$ and [] are keywords and must be written as they are. Each symbol has the following meaning.

- #: Immediate data specification
- !: Absolute address specification
- \$: Relative address specification
- []: Indirect address specification

In the case of immediate data, describe an appropriate numeric value or a label. When using a label, be sure to write the #, !, \$, and [] symbols.

For operand register identifiers *r* and *rp*, either function names (X, A, C, etc.) or absolute names (names in parentheses in the table below, R0, R1, R2, etc.) can be used for specification.

Table 23-1. Operand Identifiers and Specification Methods

Identifier	Specification Method
<i>r</i>	X (R0), A (R1), C (R2), B (R3), E (R4), D (R5), L (R6), H (R7)
<i>rp</i>	AX (RP0), BC (RP1), DE (RP2), HL (RP3)
<i>sfr</i>	Special function register symbol ^{Note}
<i>sfrp</i>	Special function register symbol (16-bit manipulatable register even addresses only) ^{Note}
<i>saddr</i>	FE20H to FF1FH Immediate data or labels
<i>saddrp</i>	FE20H to FF1FH Immediate data or labels (even address only)
<i>addr16</i>	0000H to FFFFH Immediate data or labels (Only even addresses for 16-bit data transfer instructions)
<i>addr11</i>	0800H to 0FFFH Immediate data or labels
<i>addr5</i>	0040H to 007FH Immediate data or labels (even address only)
<i>word</i>	16-bit immediate data or label
<i>byte</i>	8-bit immediate data or label
<i>bit</i>	3-bit immediate data or label
<i>RBn</i>	RB0 to RB3

Note Addresses from FFD0H to FFDFH cannot be accessed with these operands.

Remark For special function register symbols, see **Table 3-5 Special Function Register List**.

23.1.2 Description of operation column

A:	A register; 8-bit accumulator
X:	X register
B:	B register
C:	C register
D:	D register
E:	E register
H:	H register
L:	L register
AX:	AX register pair; 16-bit accumulator
BC:	BC register pair
DE:	DE register pair
HL:	HL register pair
PC:	Program counter
SP:	Stack pointer
PSW:	Program status word
CY:	Carry flag
AC:	Auxiliary carry flag
Z:	Zero flag
RBS:	Register bank select flag
IE:	Interrupt request enable flag
():	Memory contents indicated by address or register contents in parentheses
X _H , X _L :	Higher 8 bits and lower 8 bits of 16-bit register
∧:	Logical product (AND)
∨:	Logical sum (OR)
⊕:	Exclusive logical sum (exclusive OR)
—:	Inverted data
addr16:	16-bit immediate data or label
jdisp8:	Signed 8-bit data (displacement value)

23.1.3 Description of flag operation column

(Blank):	Not affected
0:	Cleared to 0
1:	Set to 1
×:	Set/cleared according to the result
R:	Previously saved value is restored

23.2 Operation List

Instruction Group	Mnemonic	Operands	Bytes	Clocks		Operation	Flag		
				Note 1	Note 2		Z	AC	CY
8-bit data transfer	MOV	r, #byte	2	4	–	r ← byte			
		saddr, #byte	3	6	7	(saddr) ← byte			
		sfr, #byte	3	–	7	sfr ← byte			
		A, r <small>Note 3</small>	1	2	–	A ← r			
		r, A <small>Note 3</small>	1	2	–	r ← A			
		A, saddr	2	4	5	A ← (saddr)			
		saddr, A	2	4	5	(saddr) ← A			
		A, sfr	2	–	5	A ← sfr			
		sfr, A	2	–	5	sfr ← A			
		A, laddr16	3	8	9	A ← (addr16)			
		laddr16, A	3	8	9	(addr16) ← A			
		PSW, #byte	3	–	7	PSW ← byte			× × ×
		A, PSW	2	–	5	A ← PSW			
		PSW, A	2	–	5	PSW ← A			× × ×
		A, [DE]	1	4	5	A ← (DE)			
		[DE], A	1	4	5	(DE) ← A			
		A, [HL]	1	4	5	A ← (HL)			
		[HL], A	1	4	5	(HL) ← A			
		A, [HL + byte]	2	8	9	A ← (HL + byte)			
		[HL + byte], A	2	8	9	(HL + byte) ← A			
	A, [HL + B]	1	6	7	A ← (HL + B)				
	[HL + B], A	1	6	7	(HL + B) ← A				
	A, [HL + C]	1	6	7	A ← (HL + C)				
	[HL + C], A	1	6	7	(HL + C) ← A				
	XCH	A, r <small>Note 3</small>	1	2	–	A ↔ r			
		A, saddr	2	4	6	A ↔ (saddr)			
		A, sfr	2	–	6	A ↔ sfr			
		A, laddr16	3	8	10	A ↔ (addr16)			
		A, [DE]	1	4	6	A ↔ (DE)			
		A, [HL]	1	4	6	A ↔ (HL)			
		A, [HL + byte]	2	8	10	A ↔ (HL + byte)			
		A, [HL + B]	2	8	10	A ↔ (HL + B)			
A, [HL + C]	2	8	10	A ↔ (HL + C)					

- Notes**
1. When the internal high-speed RAM area is accessed or for an instruction with no data access
 2. When an area except the internal high-speed RAM area is accessed
 3. Except “r = A”

- Remarks**
1. One instruction clock cycle is one cycle of the CPU clock (f_{CPU}) selected by the processor clock control register (PCC).
 2. This clock cycle applies to the internal ROM program.

Instruction Group	Mnemonic	Operands	Bytes	Clocks		Operation	Flag			
				Note 1	Note 2		Z	AC	CY	
16-bit data transfer	MOVW	rp, #word	3	6	–	$rp \leftarrow \text{word}$				
		saddrp, #word	4	8	10	$(saddrp) \leftarrow \text{word}$				
		sfrp, #word	4	–	10	$sfrp \leftarrow \text{word}$				
		AX, saddrp	2	6	8	$AX \leftarrow (saddrp)$				
		saddrp, AX	2	6	8	$(saddrp) \leftarrow AX$				
		AX, sfrp	2	–	8	$AX \leftarrow sfrp$				
		sfrp, AX	2	–	8	$sfrp \leftarrow AX$				
		AX, rp	Note 3	1	4	–	$AX \leftarrow rp$			
		rp, AX	Note 3	1	4	–	$rp \leftarrow AX$			
		AX, !addr16		3	10	12	$AX \leftarrow (\text{addr16})$			
	!addr16, AX		3	10	12	$(\text{addr16}) \leftarrow AX$				
	XCHW	AX, rp	Note 3	1	4	–	$AX \leftrightarrow rp$			
8-bit operation	ADD	A, #byte	2	4	–	$A, CY \leftarrow A + \text{byte}$	x	x	x	
		saddr, #byte	3	6	8	$(saddr), CY \leftarrow (saddr) + \text{byte}$	x	x	x	
		A, r	Note 4	2	4	–	$A, CY \leftarrow A + r$	x	x	x
		r, A		2	4	–	$r, CY \leftarrow r + A$	x	x	x
		A, saddr		2	4	5	$A, CY \leftarrow A + (saddr)$	x	x	x
		A, !addr16		3	8	9	$A, CY \leftarrow A + (\text{addr16})$	x	x	x
		A, [HL]		1	4	5	$A, CY \leftarrow A + (\text{HL})$	x	x	x
		A, [HL + byte]		2	8	9	$A, CY \leftarrow A + (\text{HL} + \text{byte})$	x	x	x
		A, [HL + B]		2	8	9	$A, CY \leftarrow A + (\text{HL} + B)$	x	x	x
	A, [HL + C]		2	8	9	$A, CY \leftarrow A + (\text{HL} + C)$	x	x	x	
	ADDC	A, #byte	2	4	–	$A, CY \leftarrow A + \text{byte} + CY$	x	x	x	
		saddr, #byte	3	6	8	$(saddr), CY \leftarrow (saddr) + \text{byte} + CY$	x	x	x	
		A, r	Note 4	2	4	–	$A, CY \leftarrow A + r + CY$	x	x	x
		r, A		2	4	–	$r, CY \leftarrow r + A + CY$	x	x	x
		A, saddr		2	4	5	$A, CY \leftarrow A + (saddr) + CY$	x	x	x
		A, !addr16		3	8	9	$A, CY \leftarrow A + (\text{addr16}) + CY$	x	x	x
		A, [HL]		1	4	5	$A, CY \leftarrow A + (\text{HL}) + CY$	x	x	x
		A, [HL + byte]		2	8	9	$A, CY \leftarrow A + (\text{HL} + \text{byte}) + CY$	x	x	x
		A, [HL + B]		2	8	9	$A, CY \leftarrow A + (\text{HL} + B) + CY$	x	x	x
A, [HL + C]			2	8	9	$A, CY \leftarrow A + (\text{HL} + C) + CY$	x	x	x	

- Notes**
1. When the internal high-speed RAM area is accessed or for an instruction with no data access
 2. When an area except the internal high-speed RAM area is accessed
 3. Only when $rp = BC, DE, \text{ or } HL$
 4. Except “ $r = A$ ”

- Remarks**
1. One instruction clock cycle is one cycle of the CPU clock (f_{CPU}) selected by the processor clock control register (PCC).
 2. This clock cycle applies to the internal ROM program.

Instruction Group	Mnemonic	Operands	Bytes	Clocks		Operation	Flag		
				Note 1	Note 2		Z	AC	CY
8-bit operation	SUB	A, #byte	2	4	–	A, CY ← A – byte	×	×	×
		saddr, #byte	3	6	8	(saddr), CY ← (saddr) – byte	×	×	×
		A, r <small>Note 3</small>	2	4	–	A, CY ← A – r	×	×	×
		r, A	2	4	–	r, CY ← r – A	×	×	×
		A, saddr	2	4	5	A, CY ← A – (saddr)	×	×	×
		A, !addr16	3	8	9	A, CY ← A – (addr16)	×	×	×
		A, [HL]	1	4	5	A, CY ← A – (HL)	×	×	×
		A, [HL + byte]	2	8	9	A, CY ← A – (HL + byte)	×	×	×
		A, [HL + B]	2	8	9	A, CY ← A – (HL + B)	×	×	×
	A, [HL + C]	2	8	9	A, CY ← A – (HL + C)	×	×	×	
	SUBC	A, #byte	2	4	–	A, CY ← A – byte – CY	×	×	×
		saddr, #byte	3	6	8	(saddr), CY ← (saddr) – byte – CY	×	×	×
		A, r <small>Note 3</small>	2	4	–	A, CY ← A – r – CY	×	×	×
		r, A	2	4	–	r, CY ← r – A – CY	×	×	×
		A, saddr	2	4	5	A, CY ← A – (saddr) – CY	×	×	×
		A, !addr16	3	8	9	A, CY ← A – (addr16) – CY	×	×	×
		A, [HL]	1	4	5	A, CY ← A – (HL) – CY	×	×	×
		A, [HL + byte]	2	8	9	A, CY ← A – (HL + byte) – CY	×	×	×
		A, [HL + B]	2	8	9	A, CY ← A – (HL + B) – CY	×	×	×
	A, [HL + C]	2	8	9	A, CY ← A – (HL + C) – CY	×	×	×	
	AND	A, #byte	2	4	–	A ← A ∧ byte	×		
		saddr, #byte	3	6	8	(saddr) ← (saddr) ∧ byte	×		
		A, r <small>Note 3</small>	2	4	–	A ← A ∧ r	×		
		r, A	2	4	–	r ← r ∧ A	×		
		A, saddr	2	4	5	A ← A ∧ (saddr)	×		
		A, !addr16	3	8	9	A ← A ∧ (addr16)	×		
		A, [HL]	1	4	5	A ← A ∧ (HL)	×		
		A, [HL + byte]	2	8	9	A ← A ∧ (HL + byte)	×		
		A, [HL + B]	2	8	9	A ← A ∧ (HL + B)	×		
	A, [HL + C]	2	8	9	A ← A ∧ (HL + C)	×			

- Notes**
1. When the internal high-speed RAM area is accessed or for an instruction with no data access
 2. When an area except the internal high-speed RAM area is accessed
 3. Except “r = A”

- Remarks**
1. One instruction clock cycle is one cycle of the CPU clock (f_{cpu}) selected by the processor clock control register (PCC).
 2. This clock cycle applies to the internal ROM program.

Instruction Group	Mnemonic	Operands	Bytes	Clocks		Operation	Flag		
				Note 1	Note 2		Z	AC	CY
8-bit operation	OR	A, #byte	2	4	–	$A \leftarrow A \vee \text{byte}$		x	
		saddr, #byte	3	6	8	$(\text{saddr}) \leftarrow (\text{saddr}) \vee \text{byte}$		x	
		A, r <small>Note 3</small>	2	4	–	$A \leftarrow A \vee r$		x	
		r, A	2	4	–	$r \leftarrow r \vee A$		x	
		A, saddr	2	4	5	$A \leftarrow A \vee (\text{saddr})$		x	
		A, !addr16	3	8	9	$A \leftarrow A \vee (\text{addr16})$		x	
		A, [HL]	1	4	5	$A \leftarrow A \vee (\text{HL})$		x	
		A, [HL + byte]	2	8	9	$A \leftarrow A \vee (\text{HL} + \text{byte})$		x	
		A, [HL + B]	2	8	9	$A \leftarrow A \vee (\text{HL} + B)$		x	
		A, [HL + C]	2	8	9	$A \leftarrow A \vee (\text{HL} + C)$		x	
	XOR	A, #byte	2	4	–	$A \leftarrow A \nabla \text{byte}$		x	
		saddr, #byte	3	6	8	$(\text{saddr}) \leftarrow (\text{saddr}) \nabla \text{byte}$		x	
		A, r <small>Note 3</small>	2	4	–	$A \leftarrow A \nabla r$		x	
		r, A	2	4	–	$r \leftarrow r \nabla A$		x	
		A, saddr	2	4	5	$A \leftarrow A \nabla (\text{saddr})$		x	
		A, !addr16	3	8	9	$A \leftarrow A \nabla (\text{addr16})$		x	
		A, [HL]	1	4	5	$A \leftarrow A \nabla (\text{HL})$		x	
		A, [HL + byte]	2	8	9	$A \leftarrow A \nabla (\text{HL} + \text{byte})$		x	
		A, [HL + B]	2	8	9	$A \leftarrow A \nabla (\text{HL} + B)$		x	
		A, [HL + C]	2	8	9	$A \leftarrow A \nabla (\text{HL} + C)$		x	
	CMP	A, #byte	2	4	–	$A - \text{byte}$	x	x	x
		saddr, #byte	3	6	8	$(\text{saddr}) - \text{byte}$	x	x	x
		A, r <small>Note 3</small>	2	4	–	$A - r$	x	x	x
		r, A	2	4	–	$r - A$	x	x	x
		A, saddr	2	4	5	$A - (\text{saddr})$	x	x	x
		A, !addr16	3	8	9	$A - (\text{addr16})$	x	x	x
		A, [HL]	1	4	5	$A - (\text{HL})$	x	x	x
		A, [HL + byte]	2	8	9	$A - (\text{HL} + \text{byte})$	x	x	x
		A, [HL + B]	2	8	9	$A - (\text{HL} + B)$	x	x	x
		A, [HL + C]	2	8	9	$A - (\text{HL} + C)$	x	x	x

- Notes**
1. When the internal high-speed RAM area is accessed or for an instruction with no data access
 2. When an area except the internal high-speed RAM area is accessed
 3. Except “r = A”

- Remarks**
1. One instruction clock cycle is one cycle of the CPU clock (f_{CPU}) selected by the processor clock control register (PCC).
 2. This clock cycle applies to the internal ROM program.

Instruction Group	Mnemonic	Operands	Bytes	Clocks		Operation	Flag		
				Note 1	Note 2		Z	AC	CY
16-bit operation	ADDW	AX, #word	3	6	–	$AX, CY \leftarrow AX + \text{word}$	x	x	x
	SUBW	AX, #word	3	6	–	$AX, CY \leftarrow AX - \text{word}$	x	x	x
	CMPW	AX, #word	3	6	–	$AX - \text{word}$	x	x	x
Multiply/divide	MULU	X	2	16	–	$AX \leftarrow A \times X$			
	DIVUW	C	2	25	–	$AX \text{ (Quotient)}, C \text{ (Remainder)} \leftarrow AX \div C$			
Increment/decrement	INC	r	1	2	–	$r \leftarrow r + 1$	x	x	
		saddr	2	4	6	$(\text{saddr}) \leftarrow (\text{saddr}) + 1$	x	x	
	DEC	r	1	2	–	$r \leftarrow r - 1$	x	x	
		saddr	2	4	6	$(\text{saddr}) \leftarrow (\text{saddr}) - 1$	x	x	
	INCW	rp	1	4	–	$rp \leftarrow rp + 1$			
	DECW	rp	1	4	–	$rp \leftarrow rp - 1$			
Rotate	ROR	A, 1	1	2	–	$(CY, A_7 \leftarrow A_0, A_{m-1} \leftarrow A_m) \times 1 \text{ time}$			x
	ROL	A, 1	1	2	–	$(CY, A_0 \leftarrow A_7, A_{m+1} \leftarrow A_m) \times 1 \text{ time}$			x
	RORC	A, 1	1	2	–	$(CY \leftarrow A_0, A_7 \leftarrow CY, A_{m-1} \leftarrow A_m) \times 1 \text{ time}$			x
	ROLC	A, 1	1	2	–	$(CY \leftarrow A_7, A_0 \leftarrow CY, A_{m+1} \leftarrow A_m) \times 1 \text{ time}$			x
	ROR4	[HL]	2	10	12	$A_{3-0} \leftarrow (HL)_{3-0}, (HL)_{7-4} \leftarrow A_{3-0}, (HL)_{3-0} \leftarrow (HL)_{7-4}$			
	ROL4	[HL]	2	10	12	$A_{3-0} \leftarrow (HL)_{7-4}, (HL)_{3-0} \leftarrow A_{3-0}, (HL)_{7-4} \leftarrow (HL)_{3-0}$			
BCD adjustment	ADJBA		2	4	–	Decimal Adjust Accumulator after Addition	x	x	x
	ADJBS		2	4	–	Decimal Adjust Accumulator after Subtract	x	x	x
Bit manipulate	MOV1	CY, saddr.bit	3	6	7	$CY \leftarrow (\text{saddr.bit})$			x
		CY, sfr.bit	3	–	7	$CY \leftarrow \text{sfr.bit}$			x
		CY, A.bit	2	4	–	$CY \leftarrow A.\text{bit}$			x
		CY, PSW.bit	3	–	7	$CY \leftarrow \text{PSW.bit}$			x
		CY, [HL].bit	2	6	7	$CY \leftarrow (HL).\text{bit}$			x
		saddr.bit, CY	3	6	8	$(\text{saddr.bit}) \leftarrow CY$			
		sfr.bit, CY	3	–	8	$\text{sfr.bit} \leftarrow CY$			
		A.bit, CY	2	4	–	$A.\text{bit} \leftarrow CY$			
		PSW.bit, CY	3	–	8	$\text{PSW.bit} \leftarrow CY$			x
[HL].bit, CY	2	6	8	$(HL).\text{bit} \leftarrow CY$					

- Notes**
1. When the internal high-speed RAM area is accessed or for an instruction with no data access
 2. When an area except the internal high-speed RAM area is accessed

- Remarks**
1. One instruction clock cycle is one cycle of the CPU clock (f_{CPU}) selected by the processor clock control register (PCC).
 2. This clock cycle applies to the internal ROM program.

Instruction Group	Mnemonic	Operands	Bytes	Clocks		Operation	Flag		
				Note 1	Note 2		Z	AC	CY
Bit manipulate	AND1	CY, saddr.bit	3	6	7	$CY \leftarrow CY \wedge (\text{saddr.bit})$			×
		CY, sfr.bit	3	–	7	$CY \leftarrow CY \wedge \text{sfr.bit}$			×
		CY, A.bit	2	4	–	$CY \leftarrow CY \wedge A.\text{bit}$			×
		CY, PSW.bit	3	–	7	$CY \leftarrow CY \wedge \text{PSW.bit}$			×
		CY, [HL].bit	2	6	7	$CY \leftarrow CY \wedge (\text{HL}).\text{bit}$			×
	OR1	CY, saddr.bit	3	6	7	$CY \leftarrow CY \vee (\text{saddr.bit})$			×
		CY, sfr.bit	3	–	7	$CY \leftarrow CY \vee \text{sfr.bit}$			×
		CY, A.bit	2	4	–	$CY \leftarrow CY \vee A.\text{bit}$			×
		CY, PSW.bit	3	–	7	$CY \leftarrow CY \vee \text{PSW.bit}$			×
		CY, [HL].bit	2	6	7	$CY \leftarrow CY \vee (\text{HL}).\text{bit}$			×
	XOR1	CY, saddr.bit	3	6	7	$CY \leftarrow CY \oplus (\text{saddr.bit})$			×
		CY, sfr.bit	3	–	7	$CY \leftarrow CY \oplus \text{sfr.bit}$			×
		CY, A.bit	2	4	–	$CY \leftarrow CY \oplus A.\text{bit}$			×
		CY, PSW.bit	3	–	7	$CY \leftarrow CY \oplus \text{PSW.bit}$			×
		CY, [HL].bit	2	6	7	$CY \leftarrow CY \oplus (\text{HL}).\text{bit}$			×
	SET1	saddr.bit	2	4	6	$(\text{saddr.bit}) \leftarrow 1$			
		sfr.bit	3	–	8	$\text{sfr.bit} \leftarrow 1$			
		A.bit	2	4	–	$A.\text{bit} \leftarrow 1$			
		PSW.bit	2	–	6	$\text{PSW.bit} \leftarrow 1$	×	×	×
		[HL].bit	2	6	8	$(\text{HL}).\text{bit} \leftarrow 1$			
	CLR1	saddr.bit	2	4	6	$(\text{saddr.bit}) \leftarrow 0$			
		sfr.bit	3	–	8	$\text{sfr.bit} \leftarrow 0$			
		A.bit	2	4	–	$A.\text{bit} \leftarrow 0$			
		PSW.bit	2	–	6	$\text{PSW.bit} \leftarrow 0$	×	×	×
		[HL].bit	2	6	8	$(\text{HL}).\text{bit} \leftarrow 0$			
	SET1	CY	1	2	–	$CY \leftarrow 1$			1
	CLR1	CY	1	2	–	$CY \leftarrow 0$			0
	NOT1	CY	1	2	–	$CY \leftarrow \overline{CY}$			×

- Notes**
1. When the internal high-speed RAM area is accessed or for an instruction with no data access
 2. When an area except the internal high-speed RAM area is accessed

- Remarks**
1. One instruction clock cycle is one cycle of the CPU clock (f_{CPU}) selected by the processor clock control register (PCC).
 2. This clock cycle applies to the internal ROM program.

Instruction Group	Mnemonic	Operands	Bytes	Clocks		Operation	Flag		
				Note 1	Note 2		Z	AC	CY
Call/return	CALL	!addr16	3	7	–	$(SP - 1) \leftarrow (PC + 3)_H, (SP - 2) \leftarrow (PC + 3)_L,$ $PC \leftarrow \text{addr16}, SP \leftarrow SP - 2$			
	CALLF	!addr11	2	5	–	$(SP - 1) \leftarrow (PC + 2)_H, (SP - 2) \leftarrow (PC + 2)_L,$ $PC_{15-11} \leftarrow 00001, PC_{10-0} \leftarrow \text{addr11},$ $SP \leftarrow SP - 2$			
	CALLT	[addr5]	1	6	–	$(SP - 1) \leftarrow (PC + 1)_H, (SP - 2) \leftarrow (PC + 1)_L,$ $PC_H \leftarrow (00000000, \text{addr5} + 1),$ $PC_L \leftarrow (00000000, \text{addr5}),$ $SP \leftarrow SP - 2$			
	BRK		1	6	–	$(SP - 1) \leftarrow PSW, (SP - 2) \leftarrow (PC + 1)_H,$ $(SP - 3) \leftarrow (PC + 1)_L, PC_H \leftarrow (003FH),$ $PC_L \leftarrow (003EH), SP \leftarrow SP - 3, IE \leftarrow 0$			
	RET		1	6	–	$PC_H \leftarrow (SP + 1), PC_L \leftarrow (SP),$ $SP \leftarrow SP + 2$			
	RETI		1	6	–	$PC_H \leftarrow (SP + 1), PC_L \leftarrow (SP),$ $PSW \leftarrow (SP + 2), SP \leftarrow SP + 3$	R	R	R
	RETB		1	6	–	$PC_H \leftarrow (SP + 1), PC_L \leftarrow (SP),$ $PSW \leftarrow (SP + 2), SP \leftarrow SP + 3$	R	R	R
Stack manipulate	PUSH	PSW	1	2	–	$(SP - 1) \leftarrow PSW, SP \leftarrow SP - 1$			
		rp	1	4	–	$(SP - 1) \leftarrow rp_H, (SP - 2) \leftarrow rp_L,$ $SP \leftarrow SP - 2$			
	POP	PSW	1	2	–	$PSW \leftarrow (SP), SP \leftarrow SP + 1$	R	R	R
		rp	1	4	–	$rp_H \leftarrow (SP + 1), rp_L \leftarrow (SP),$ $SP \leftarrow SP + 2$			
	MOVW	SP, #word	4	–	10	$SP \leftarrow \text{word}$			
		SP, AX	2	–	8	$SP \leftarrow AX$			
AX, SP		2	–	8	$AX \leftarrow SP$				
Unconditional branch	BR	!addr16	3	6	–	$PC \leftarrow \text{addr16}$			
		\$addr16	2	6	–	$PC \leftarrow PC + 2 + \text{jdisp8}$			
		AX	2	8	–	$PC_H \leftarrow A, PC_L \leftarrow X$			
Conditional branch	BC	\$addr16	2	6	–	$PC \leftarrow PC + 2 + \text{jdisp8}$ if CY = 1			
		\$addr16	2	6	–	$PC \leftarrow PC + 2 + \text{jdisp8}$ if CY = 0			
		\$addr16	2	6	–	$PC \leftarrow PC + 2 + \text{jdisp8}$ if Z = 1			
		\$addr16	2	6	–	$PC \leftarrow PC + 2 + \text{jdisp8}$ if Z = 0			

- Notes**
1. When the internal high-speed RAM area is accessed or for an instruction with no data access
 2. When an area except the internal high-speed RAM area is accessed

- Remarks**
1. One instruction clock cycle is one cycle of the CPU clock (f_{CPU}) selected by the processor clock control register (PCC).
 2. This clock cycle applies to the internal ROM program.

Instruction Group	Mnemonic	Operands	Bytes	Clocks		Operation	Flag		
				Note 1	Note 2		Z	AC	CY
Conditional branch	BT	saddr.bit, \$addr16	3	8	9	PC ← PC + 3 + jdisp8 if (saddr.bit) = 1			
		sfr.bit, \$addr16	4	–	11	PC ← PC + 4 + jdisp8 if sfr.bit = 1			
		A.bit, \$addr16	3	8	–	PC ← PC + 3 + jdisp8 if A.bit = 1			
		PSW.bit, \$addr16	3	–	9	PC ← PC + 3 + jdisp8 if PSW.bit = 1			
		[HL].bit, \$addr16	3	10	11	PC ← PC + 3 + jdisp8 if (HL).bit = 1			
	BF	saddr.bit, \$addr16	4	10	11	PC ← PC + 4 + jdisp8 if (saddr.bit) = 0			
		sfr.bit, \$addr16	4	–	11	PC ← PC + 4 + jdisp8 if sfr.bit = 0			
		A.bit, \$addr16	3	8	–	PC ← PC + 3 + jdisp8 if A.bit = 0			
		PSW.bit, \$addr16	4	–	11	PC ← PC + 4 + jdisp8 if PSW.bit = 0			
		[HL].bit, \$addr16	3	10	11	PC ← PC + 3 + jdisp8 if (HL).bit = 0			
	BTCLR	saddr.bit, \$addr16	4	10	12	PC ← PC + 4 + jdisp8 if (saddr.bit) = 1 then reset (saddr.bit)			
		sfr.bit, \$addr16	4	–	12	PC ← PC + 4 + jdisp8 if sfr.bit = 1 then reset sfr.bit			
		A.bit, \$addr16	3	8	–	PC ← PC + 3 + jdisp8 if A.bit = 1 then reset A.bit			
		PSW.bit, \$addr16	4	–	12	PC ← PC + 4 + jdisp8 if PSW.bit = 1 then reset PSW.bit	×	×	×
		[HL].bit, \$addr16	3	10	12	PC ← PC + 3 + jdisp8 if (HL).bit = 1 then reset (HL).bit			
	DBNZ	B, \$addr16	2	6	–	B ← B – 1, then PC ← PC + 2 + jdisp8 if B ≠ 0			
		C, \$addr16	2	6	–	C ← C – 1, then PC ← PC + 2 + jdisp8 if C ≠ 0			
		saddr, \$addr16	3	8	10	(saddr) ← (saddr) – 1, then PC ← PC + 3 + jdisp8 if (saddr) ≠ 0			
CPU control	SEL	RBn	2	4	–	RBS1, 0 ← n			
	NOP		1	2	–	No Operation			
	EI		2	–	6	IE ← 1 (Enable Interrupt)			
	DI		2	–	6	IE ← 0 (Disable Interrupt)			
	HALT		2	6	–	Set HALT Mode			
	STOP		2	6	–	Set STOP Mode			

- Notes**
1. When the internal high-speed RAM area is accessed or for an instruction with no data access
 2. When an area except the internal high-speed RAM area is accessed

- Remarks**
1. One instruction clock cycle is one cycle of the CPU clock (f_{CPU}) selected by the processor clock control register (PCC).
 2. This clock cycle applies to the internal ROM program.

23.3 Instructions Listed by Addressing Type

(1) 8-bit instructions

MOV, XCH, ADD, ADDC, SUB, SUBC, AND, OR, XOR, CMP, MULU, DIVUW, INC, DEC, ROR, ROL, RORC, ROLC, ROR4, ROL4, PUSH, POP, DBNZ

Second Operand First Operand	#byte	A	r ^{Note}	sfr	saddr	!addr16	PSW	[DE]	[HL]	[HL + byte] [HL + B] [HL + C]	\$addr16	1	None
A	ADD ADDC SUB SUBC AND OR XOR CMP		MOV XCH ADD ADDC SUB SUBC AND OR XOR CMP	MOV XCH	MOV XCH ADD ADDC SUB SUBC AND OR XOR CMP	MOV XCH ADD ADDC SUB SUBC AND OR XOR CMP	MOV	MOV XCH	MOV XCH ADD ADDC SUB SUBC AND OR XOR CMP	MOV XCH ADD ADDC SUB SUBC AND OR XOR CMP		ROR ROL RORC ROLC	
r	MOV	MOV ADD ADDC SUB SUBC AND OR XOR CMP											INC DEC
B, C											DBNZ		
sfr	MOV	MOV											
saddr	MOV ADD ADDC SUB SUBC AND OR XOR CMP	MOV									DBNZ		INC DEC
!addr16		MOV											
PSW	MOV	MOV											PUSH POP
[DE]		MOV											
[HL]		MOV											ROR4 ROL4
[HL + byte] [HL + B] [HL + C]		MOV											
X													MULU
C													DIVUW

Note Except "r = A"

(2) 16-bit instructions

MOVW, XCHW, ADDW, SUBW, CMPW, PUSH, POP, INCW, DECW

Second Operand First Operand	#word	AX	rp ^{Note}	sfrp	saddrp	laddr16	SP	None
AX	ADDW SUBW CMPW		MOVW XCHW	MOVW	MOVW	MOVW	MOVW	
rp	MOVW	MOVW ^{Note}						INCW DECW PUSH POP
sfrp	MOVW	MOVW						
saddrp	MOVW	MOVW						
laddr16		MOVW						
SP	MOVW	MOVW						

Note Only when rp = BC, DE, HL

(3) Bit manipulation instructions

MOV1, AND1, OR1, XOR1, SET1, CLR1, NOT1, BT, BF, BTCLR

Second Operand First Operand	A.bit	sfr.bit	saddr.bit	PSW.bit	[HL].bit	CY	\$addr16	None
A.bit						MOV1	BT BF BTCLR	SET1 CLR1
sfr.bit						MOV1	BT BF BTCLR	SET1 CLR1
saddr.bit						MOV1	BT BF BTCLR	SET1 CLR1
PSW.bit						MOV1	BT BF BTCLR	SET1 CLR1
[HL].bit						MOV1	BT BF BTCLR	SET1 CLR1
CY	MOV1 AND1 OR1 XOR1	MOV1 AND1 OR1 XOR1	MOV1 AND1 OR1 XOR1	MOV1 AND1 OR1 XOR1	MOV1 AND1 OR1 XOR1			SET1 CLR1 NOT1

(4) Call instructions/branch instructions

CALL, CALLF, CALLT, BR, BC, BNC, BZ, BNZ, BT, BF, BTCLR, DBNZ

Second Operand First Operand	AX	!addr16	!addr11	[addr5]	\$addr16
Basic instruction	BR	CALL BR	CALLF	CALLT	BR BC BNC BZ BNZ
Compound instruction					BT BF BTCLR DBNZ

(5) Other instructions

ADJBA, ADJBS, BRK, RET, RETI, RETB, SEL, NOP, EI, DI, HALT, STOP

CHAPTER 24 ELECTRICAL SPECIFICATIONS (STANDARD PRODUCTS)

Target products: μ PD78F0500, 78F0501, 78F0502, 78F0503, 78F0503D

Caution The μ PD78F0503D has an on-chip debug function. Do not use this product for mass production because its reliability cannot be guaranteed after the on-chip debug function has been used, given the issue of the number of times the flash memory can be rewritten. NEC Electronics does not accept complaints concerning this product.

Absolute Maximum Ratings ($T_A = 25^\circ\text{C}$) (1/2)

Parameter	Symbol	Conditions	Ratings	Unit	
Supply voltage	V_{DD}		-0.5 to +6.5	V	
	EV_{DD}		-0.5 to +6.5	V	
	V_{SS}		-0.5 to +0.3	V	
	EV_{SS}		-0.5 to +0.3	V	
	AV_{REF}		-0.5 to $V_{DD} + 0.3^{\text{Note}}$	V	
	AV_{SS}		-0.5 to +0.3	V	
Input voltage	V_{I1}	P00, P01, P10 to P17, P20 to P23, P30 to P33, P120 to P122, X1, X2, RESET	-0.3 to $V_{DD} + 0.3^{\text{Note}}$	V	
	V_{I2}	P60, P61 (N-ch open drain)	-0.3 to +6.5	V	
Output voltage	V_O		-0.3 to $V_{DD} + 0.3^{\text{Note}}$	V	
Analog input voltage	V_{AN}	ANI0 to ANI3	-0.3 to $AV_{REF} + 0.3^{\text{Note}}$ and -0.3 to $V_{DD} + 0.3^{\text{Note}}$	V	
Output current, high	I_{OH}	Per pin	P00, P01, P10 to P17, P30 to P33, P120	-10	mA
		Total of all pins -80 mA	P00, P01, P120	-25	mA
			P10 to P17, P30 to P33	-55	mA
		Per pin	P20 to P23	-0.5	mA
		Total of all pins		-2	mA
		Per pin	P121, P122	-1	mA
		Total of all pins		-4	mA

Note Must be 6.5 V or lower.

Caution Product quality may suffer if the absolute maximum rating is exceeded even momentarily for any parameter. That is, the absolute maximum ratings are rated values at which the product is on the verge of suffering physical damage, and therefore the product must be used under conditions that ensure that the absolute maximum ratings are not exceeded.

Remark Unless specified otherwise, the characteristics of alternate-function pins are the same as those of port pins.

Absolute Maximum Ratings ($T_A = 25^\circ\text{C}$) (2/2)

Parameter	Symbol	Conditions		Ratings	Unit
<R> Output current, low	I_{OL}	Per pin	P00, P01, P10 to P17, P30 to P33, P60, P61, P120	30	mA
		Total of all pins 200 mA	P00, P01, P120	60	mA
			P10 to P17, P30 to P33, P60, P61	140	mA
		Per pin	P20 to P23	1	mA
		Total of all pins		5	mA
		Per pin	P121, P122	4	mA
		Total of all pins		10	mA
Operating ambient temperature	T_A	In normal operation mode		-40 to +85	$^\circ\text{C}$
		In flash memory programming mode			
Storage temperature	T_{stg}			-40 to +150	$^\circ\text{C}$

Caution Product quality may suffer if the absolute maximum rating is exceeded even momentarily for any parameter. That is, the absolute maximum ratings are rated values at which the product is on the verge of suffering physical damage, and therefore the product must be used under conditions that ensure that the absolute maximum ratings are not exceeded.

Remark Unless specified otherwise, the characteristics of alternate-function pins are the same as those of port pins.

X1 Oscillator Characteristics(T_A = -40 to +85°C, 1.8 V ≤ V_{DD} = EV_{DD} ≤ 5.5 V, V_{SS} = EV_{SS} = AV_{SS} = 0 V)

Resonator	Recommended Circuit	Parameter	Conditions	MIN.	TYP.	MAX.	Unit
Ceramic resonator		X1 clock oscillation frequency (f _x) ^{Note}	4.0 V ≤ V _{DD} ≤ 5.5 V	1.0		20.0	MHz
			2.7 V ≤ V _{DD} < 4.0 V	1.0		10.0	
			1.8 V ≤ V _{DD} < 2.7 V	1.0		5.0	
Crystal resonator		X1 clock oscillation frequency (f _x) ^{Note}	4.0 V ≤ V _{DD} ≤ 5.5 V	1.0		20.0	MHz
			2.7 V ≤ V _{DD} < 4.0 V	1.0		10.0	
			1.8 V ≤ V _{DD} < 2.7 V	1.0		5.0	

Note Indicates only oscillator characteristics. Refer to **AC Characteristics** for instruction execution time.**Cautions 1.** When using the X1 oscillator, wire as follows in the area enclosed by the broken lines in the above figures to avoid an adverse effect from wiring capacitance.

- Keep the wiring length as short as possible.
- Do not cross the wiring with the other signal lines.
- Do not route the wiring near a signal line through which a high fluctuating current flows.
- Always make the ground point of the oscillator capacitor the same potential as V_{SS}.
- Do not ground the capacitor to a ground pattern through which a high current flows.
- Do not fetch signals from the oscillator.

2. Since the CPU is started by the internal high-speed oscillation clock after a reset release, check the X1 clock oscillation stabilization time using the oscillation stabilization time counter status register (OSTC) by the user. Determine the oscillation stabilization time of the OSTC register and oscillation stabilization time select register (OSTS) after sufficiently evaluating the oscillation stabilization time with the resonator to be used.

Internal Oscillator Characteristics(T_A = -40 to +85°C, 1.8 V ≤ V_{DD} = EV_{DD} ≤ 5.5 V, V_{SS} = EV_{SS} = AV_{SS} = 0 V)

Resonator	Parameter	Conditions	MIN.	TYP.	MAX.	Unit	
<R> 8 MHz internal oscillator	Internal high-speed oscillation clock frequency (f _{RH}) ^{Note}	RSTS = 1	2.7 V ≤ V _{DD} ≤ 5.5 V	7.6	8.0	8.4	MHz
			1.8 V ≤ V _{DD} < 2.7 V	7.6	8.0	10.4	MHz
		RSTS = 0		2.48	5	9.86	MHz
<R> 240 kHz internal oscillator	Internal low-speed oscillation clock frequency (f _{RL})		2.7 V ≤ V _{DD} ≤ 5.5 V	216	240	264	kHz
			1.8 V ≤ V _{DD} < 2.7 V	192	240	264	kHz

Note Indicates only oscillator characteristics. Refer to **AC Characteristics** for instruction execution time.**Remark** RSTS: Bit 7 of the internal oscillation mode register (RCM))

<R>

Recommended Oscillator Constants

X1 oscillation: Ceramic resonator (T_A = -40 to +85°C) (1/2)

Manufacturer	Part Number	SMD/ Lead	Frequency (MHz)	Recommended Circuit Constants		Oscillation Voltage Range		
				C1 (pF)	C2 (pF)	MIN. (V)	MAX. (V)	
Murata Mfg. Co., Ltd.	CSTCC2M00G56-R0	SMD	2.00	Internal (47)	Internal (47)	1.8	5.5	
	CSTLS4M00G56-B0	Lead	4.00	Internal (47)	Internal (47)			
	CSTCR4M00G55-R0	SMD		Internal (39)	Internal (39)			
	CSTLS4M19G56-B0	Lead	4.194	Internal (47)	Internal (47)			
	CSTCR4M19G55-R0	SMD		Internal (39)	Internal (39)			
	CSTLS4M91G56-B0	Lead	4.915	Internal (47)	Internal (47)			
	CSTCR4M91G55-R0	SMD		Internal (39)	Internal (39)			
	CSTLS5M00G56-B0	Lead	5.00	Internal (47)	Internal (47)			1.9
	CSTCR5M00G55-R0	SMD		Internal (39)	Internal (39)			1.8
	CSTLS6M00G56-B0	Lead	6.00	Internal (47)	Internal (47)			2.4
	CSTCR6M00G55-R0	SMD		Internal (39)	Internal (39)			1.8
	CSTLS8M00G56-B0	Lead	8.00	Internal (47)	Internal (47)			2.3
	CSTCE8M00G55-R0	SMD		Internal (33)	Internal (33)			1.9
	CSTLS8M38G56-B0	Lead	8.388	Internal (47)	Internal (47)			2.3
	CSTCE8M38G55-R0	SMD		Internal (33)	Internal (33)			1.9
	CSTLS10M0G56-B0	Lead	10.0	Internal (47)	Internal (47)			2.5
	CSTCE10M0G55-R0	SMD		Internal (33)	Internal (33)			2.3
	CSTCE12M0G55-R0	SMD	12.0	Internal (33)	Internal (33)			2.3
	CSTCE16M0V53-R0	SMD	16.0	Internal (15)	Internal (15)			2.3
	CSTCE20M0V53-R0	SMD	20.0	Internal (15)	Internal (15)			2.6
Murata Mfg. Co., Ltd. (low-capacitance products)	CSTLS6M00G53-B0	Lead	6.00	Internal (15)	Internal (15)	1.8	5.5	
	CSTLS8M00G53-B0	Lead	8.00	Internal (15)	Internal (15)			
	CSTLS8M38G53-B0	Lead	8.388	Internal (15)	Internal (15)			
	CSTLS10M0G53-B0	Lead	10.0	Internal (15)	Internal (15)			
	CSTCE12M0G52-R0	SMD	12.0	Internal (10)	Internal (10)			
	CSTCE16M0V51-R0	SMD	16.0	Internal (5)	Internal (5)			
	CSTCE20M0V51-R0	SMD	20.0	Internal (5)	Internal (5)			

Caution The oscillator constants shown above are reference values based on evaluation in a specific environment by the resonator manufacturer. If it is necessary to optimize the oscillator characteristics in the actual application, apply to the resonator manufacturer for evaluation on the implementation circuit. The oscillation voltage and oscillation frequency only indicate the oscillator characteristic. Use the 78K0/KB2 so that the internal operation conditions are within the specifications of the DC and AC characteristics.

X1 oscillation: Ceramic resonator ($T_A = -40$ to $+85^\circ\text{C}$) (2/2)

Manufacturer	Part Number	SMD/ Lead	Frequency (MHz)	Recommended Circuit Constants		Oscillation Voltage Range	
				C1 (pF)	C2 (pF)	MIN. (V)	MAX. (V)
TDK Corporation	CCR4.0MUC8	SMD	4.00	Internal (27)	Internal (27)	1.8	5.5
	FCR4.0MC5	Lead		Internal (30)	Internal (30)		
	CCR8.0MXC8	SMD	8.00	Internal (18)	Internal (30)		
	FCR8.0MC5	Lead		Internal (20)	Internal (20)		

Caution The oscillator constants shown above are reference values based on evaluation in a specific environment by the resonator manufacturer. If it is necessary to optimize the oscillator characteristics in the actual application, apply to the resonator manufacturer for evaluation on the implementation circuit. The oscillation voltage and oscillation frequency only indicate the oscillator characteristic. Use the 78K0/KB2 so that the internal operation conditions are within the specifications of the DC and AC characteristics.

DC Characteristics (1/4)

(T_A = -40 to +85°C, 1.8 V ≤ V_{DD} = EV_{DD} ≤ 5.5 V, AV_{REF} ≤ V_{DD}, V_{SS} = EV_{SS} = AV_{SS} = 0 V)

Parameter	Symbol	Conditions	MIN.	TYP.	MAX.	Unit
Output current, high ^{Note 1}	IOH1	Per pin for P00, P01, P10 to P17, P30 to P33, P120	4.0 V ≤ V _{DD} ≤ 5.5 V		-3.0	mA
			2.7 V ≤ V _{DD} < 4.0 V		-2.5	mA
			1.8 V ≤ V _{DD} < 2.7 V		-1.0	mA
		Total of P00, P01, P120 ^{Note 3}	4.0 V ≤ V _{DD} ≤ 5.5 V		-12.9	mA
			2.7 V ≤ V _{DD} < 4.0 V		-10	mA
			1.8 V ≤ V _{DD} < 2.7 V		-4.3	mA
		Total of P10 to P17, P30 to P33 ^{Note 3}	4.0 V ≤ V _{DD} ≤ 5.5 V		-30.0	mA
			2.7 V ≤ V _{DD} < 4.0 V		-19.0	mA
			1.8 V ≤ V _{DD} < 2.7 V		-10.0	mA
	Total ^{Note 3} of all pins	4.0 V ≤ V _{DD} ≤ 5.5 V		-50.0	mA	
		2.7 V ≤ V _{DD} < 4.0 V		-29.0	mA	
		1.8 V ≤ V _{DD} < 2.7 V		-15.0	mA	
	IOH2	Per pin for P20 to P23	AV _{REF} = V _{DD}		-0.1	mA
			Per pin for P121, P122		-0.1	mA
	Output current, low ^{Note 2}	IOL1	Per pin for P00, P01, P10 to P17, P30 to P33, P120	4.0 V ≤ V _{DD} ≤ 5.5 V		8.5
2.7 V ≤ V _{DD} < 4.0 V					5.0	mA
1.8 V ≤ V _{DD} < 2.7 V					2.0	mA
Per pin for P60, P61			4.0 V ≤ V _{DD} ≤ 5.5 V		15.0	mA
			2.7 V ≤ V _{DD} < 4.0 V		5.0	mA
			1.8 V ≤ V _{DD} < 2.7 V		2.0	mA
Total of P00, P01, P120 ^{Note 3}			4.0 V ≤ V _{DD} ≤ 5.5 V		20.0	mA
			2.7 V ≤ V _{DD} < 4.0 V		15.0	mA
			1.8 V ≤ V _{DD} < 2.7 V		8.6	mA
Total of P10 to P17, P30 to P33, P60, P61 ^{Note 3}		4.0 V ≤ V _{DD} ≤ 5.5 V		45.0	mA	
		2.7 V ≤ V _{DD} < 4.0 V		35.0	mA	
		1.8 V ≤ V _{DD} < 2.7 V		20.0	mA	
Total of all pins ^{Note 3}		4.0 V ≤ V _{DD} ≤ 5.5 V		65.0	mA	
		2.7 V ≤ V _{DD} < 4.0 V		50.0	mA	
		1.8 V ≤ V _{DD} < 2.7 V		28.6	mA	
IOL2		Per pin for P20 to P23	AV _{REF} = V _{DD}		0.4	mA
			Per pin for P121, P122		0.4	mA

Notes 1. Value of current at which the device operation is guaranteed even if the current flows from V_{DD} to an output pin.

2. Value of current at which the device operation is guaranteed even if the current flows from an output pin to GND.

3. Specification under conditions where the duty factor is 70% (time for which current is output is 0.7 × t and time for which current is not output is 0.3 × t, where t is a specific time). The total output current of the pins at a duty factor of other than 70% can be calculated by the following expression.

- Where the duty factor of I_{OH} is n%: Total output current of pins = (I_{OH} × 0.7)/(n × 0.01)

<Example> Where the duty factor is 50%, I_{OH} = 20.0 mA

$$\text{Total output current of pins} = (20.0 \times 0.7)/(50 \times 0.01) = 28.0 \text{ mA}$$

However, the current that is allowed to flow into one pin does not vary depending on the duty factor. A current higher than the absolute maximum rating must not flow into one pin.

Remark Unless specified otherwise, the characteristics of alternate-function pins are the same as those of port pins.

DC Characteristics (2/4)

(T_A = -40 to +85°C, 1.8 V ≤ V_{DD} = EV_{DD} ≤ 5.5 V, AV_{REF} ≤ V_{DD}, V_{SS} = EV_{SS} = AV_{SS} = 0 V)

Parameter	Symbol	Conditions	MIN.	TYP.	MAX.	Unit
Input voltage, high	V _{IH1}	P12, P13, P15, P121, P122	0.7V _{DD}		V _{DD}	V
	V _{IH2}	P00, P01, P10, P11, P14, P16, P17, P30 to P33, P120, RESET	0.8V _{DD}		V _{DD}	V
	V _{IH3}	P20 to P23	AV _{REF} = V _{DD}		AV _{REF}	V
	V _{IH4}	P60, P61			6.0	V
Input voltage, low	V _{IL1}	P12, P13, P15, P60, P61, P121, P122	0		0.3V _{DD}	V
	V _{IL2}	P00, P01, P10, P11, P14, P16, P17, P30 to P33, P120, RESET	0		0.2V _{DD}	V
	V _{IL3}	P20 to P23	AV _{REF} = V _{DD}		0.3AV _{REF}	V
Output voltage, high	V _{OH1}	P00, P01, P10 to P17, P30 to P33, P120	4.0 V ≤ V _{DD} ≤ 5.5 V, I _{OH1} = -3.0 mA		V _{DD} - 0.7	V
			2.7 V ≤ V _{DD} < 4.0 V, I _{OH1} = -2.5 mA		V _{DD} - 0.5	V
			1.8 V ≤ V _{DD} < 2.7 V, I _{OH1} = -1.0 mA		V _{DD} - 0.5	V
	V _{OH2}	P20 to P23 P121, P122	AV _{REF} = V _{DD} , I _{OH2} = -100 μA		V _{DD} - 0.5	V
			I _{OH2} = -100 μA		V _{DD} - 0.5	V
Output voltage, low	V _{OL1}	P00, P01, P10 to P17, P30 to P33, P120	4.0 V ≤ V _{DD} ≤ 5.5 V, I _{OL1} = 8.5 mA		0.7	V
			2.7 V ≤ V _{DD} < 4.0 V, I _{OL1} = 5.0 mA		0.7	V
			1.8 V ≤ V _{DD} < 2.7 V, I _{OL1} = 2.0 mA		0.5	V
			1.8 V ≤ V _{DD} < 2.7 V, I _{OL1} = 0.5 mA		0.4	V
	V _{OL2}	P20 to P23 P121, P122	AV _{REF} = V _{DD} , I _{OL2} = 0.4 mA		0.4	V
			I _{OL2} = 0.4 mA		0.4	V
	V _{OL3}	P60, P61	4.0 V ≤ V _{DD} ≤ 5.5 V, I _{OL1} = 15.0 mA		2.0	V
			4.0 V ≤ V _{DD} ≤ 5.5 V, I _{OL1} = 5.0 mA		0.4	V
			2.7 V ≤ V _{DD} < 4.0 V, I _{OL1} = 5.0 mA		0.6	V
			2.7 V ≤ V _{DD} < 4.0 V, I _{OL1} = 3.0 mA		0.4	V
			1.8 V ≤ V _{DD} < 2.7 V, I _{OL1} = 2.0 mA		0.4	V

Remark Unless specified otherwise, the characteristics of alternate-function pins are the same as those of port pins.

DC Characteristics (3/4)

(T_A = -40 to +85°C, 1.8 V ≤ V_{DD} = E_{VDD} ≤ 5.5 V, A_{VREF} ≤ V_{DD}, V_{SS} = E_{VSS} = A_{VSS} = 0 V)

Parameter	Symbol	Conditions		MIN.	TYP.	MAX.	Unit	
Input leakage current, high	I _{LIH1}	P00, P01, P10 to P17, P30 to P33, P120	V _I = V _{DD}			1	μA	
	I _{LIH2}	P20 to P23	V _I = A _{VREF} = V _{DD}			1	μA	
	I _{LIH3}	P121, P122 (X1, X2)	V _I = V _{DD}	I/O port mode			1	μA
				OSC mode			20	μA
Input leakage current, low	I _{LIL1}	P00, P01, P10 to P17, P30 to P33, P60, P61, P120	V _I = V _{SS}			-1	μA	
	I _{LIL2}	P20 to P23	V _I = V _{SS} , A _{VREF} = V _{DD}			-1	μA	
	I _{LIL3}	P121, P122 (X1, X2)	V _I = V _{SS}	I/O port mode			-1	μA
				OSC mode			-20	μA
Pull-up resistor	R _U	V _I = V _{DD}		10	20	100	kΩ	
FLMD0 supply voltage	V _{IL}	In normal operation mode		0		0.2V _{DD}	V	
	V _{IH}	In self-programming mode		0.8V _{DD}		V _{DD}	V	
<R> External clock input voltage	V _{IL}	P122	In external clock input mode	0		0.3V _{DD}	V	
	V _{IH}			0.7V _{DD}		V _{DD}	V	

Remark Unless specified otherwise, the characteristics of alternate-function pins are the same as those of port pins.

DC Characteristics (4/4)

(T_A = -40 to +85°C, 1.8 V ≤ V_{DD} = EV_{DD} ≤ 5.5 V, AV_{REF} ≤ V_{DD}, V_{SS} = EV_{SS} = AV_{SS} = 0 V)

Parameter	Symbol	Conditions		MIN.	TYP.	MAX.	Unit	
<R> Supply current	I _{DD1} ^{Note 1}	Operating mode	f _{XH} = 20 MHz ^{Note 2} , V _{DD} = 5.0 V	Square wave input		3.2	5.5	mA
				Resonator connection		4.5	6.9	
			f _{XH} = 10 MHz ^{Notes 2, 3} , V _{DD} = 5.0 V	Square wave input		1.6	2.8	mA
				Resonator connection		2.3	3.9	
			f _{XH} = 10 MHz ^{Notes 2, 3} , V _{DD} = 3.0 V	Square wave input		1.5	2.7	mA
				Resonator connection		2.2	3.2	
			f _{XH} = 5 MHz ^{Notes 2, 3} , V _{DD} = 3.0 V	Square wave input		0.9	1.6	mA
				Resonator connection		1.3	2.0	
	f _{XH} = 5 MHz ^{Notes 2, 3} , V _{DD} = 2.0 V	Square wave input		0.7	1.4	mA		
		Resonator connection		1.0	1.6			
	f _{RH} = 8 MHz, V _{DD} = 5.0 V				1.4	2.5	mA	
	I _{DD2} ^{Note 4}	HALT mode	f _{XH} = 20 MHz ^{Note 2} , V _{DD} = 5.0 V	Square wave input		0.8	2.6	mA
				Resonator connection		2.0	4.4	
			f _{XH} = 10 MHz ^{Notes 2, 3} , V _{DD} = 5.0 V	Square wave input		0.4	1.3	mA
Resonator connection					1.0	2.4		
f _{XH} = 5 MHz ^{Notes 2, 3} , V _{DD} = 3.0 V			Square wave input		0.2	0.65	mA	
			Resonator connection		0.5	1.1		
f _{RH} = 8 MHz, V _{DD} = 5.0 V				0.4	1.2	mA		
I _{DD3} ^{Note 4}			STOP mode	V _{DD} = 5.0 V			1	20
	V _{DD} = 5.0 V, T _A = -40 to +70°C				1	10	μA	
<R> A/D converter operating current	I _{ADC} ^{Note 5}	During conversion at maximum speed	2.3 V ≤ AV _{REF} ≤ V _{DD}		0.86	1.9	mA	
		Not during conversion (comparator operation) ^{Note 6}			0.6	1.2		
Watchdog timer operating current	I _{WDT} ^{Note 7}	During 240 kHz internal low-speed oscillation clock operation			5	10	μA	
<R> LVI operating current	I _{LVI} ^{Note 8}				9	18	μA	

Remarks 1. f_{XH}: High-speed system clock frequency (X1 clock oscillation frequency or external main system clock frequency)

2. f_{RH}: Internal high-speed oscillation clock frequency

(Notes on next page)

- <R> **Notes** 1. Total current flowing into the internal power supply (V_{DD} , EV_{DD} , AV_{REF}), including the peripheral operation current (however, the current flowing into the pull-up resistors of the port, and A/D converter is not included).
- <R> 2. Not including the operating current of the internal high-speed clock (f_{RH})
- <R> 3. When AMPH (bit 0 of clock operation mode select register (OSCCTL)) = 0.
- <R> 4. Total current flowing into the internal power supply (V_{DD} , EV_{DD} , AV_{REF}), including the peripheral operating current (however, the current flowing into the pull-up resistor of the port, A/D converter, watchdog timer, and LVI circuit is not included)
- <R> 5. Current flowing only to the A/D converter. The current value of the 78K0/KB2 is the sum of I_{DD1} or I_{DD2} and I_{ADC} when the A/D converter operates in an operation mode or the HALT mode.
- <R> 6. Current when ADCE (bit 0 of A/D converter mode register (ADM)) = 1 and ADCS (bit 7 of ADM) = 0
- <R> 7. Current flowing only to the watchdog timer. The current value of the 78K0/KB2 is the sum of I_{DD2} or I_{DD3} and I_{WDT} when the watchdog timer operates in the HALT or STOP mode.
- <R> 8. Current flowing only to the LVI circuit. The current value of the 78K0/KB2 is the sum of I_{DD2} or I_{DD3} and I_{LVI} when the LVI circuit operates in the HALT or STOP mode.

AC Characteristics

(1) Basic operation

(T_A = -40 to +85°C, 1.8 V ≤ V_{DD} = EV_{DD} ≤ 5.5 V, AV_{REF} ≤ V_{DD}, V_{SS} = EV_{SS} = AV_{SS} = 0 V)

Parameter	Symbol	Conditions	MIN.	TYP.	MAX.	Unit	
Instruction cycle (minimum instruction execution time)	T _{CY}	Main system clock (f _{XP}) operation	4.0 V ≤ V _{DD} ≤ 5.5 V	0.1		32	μs
			2.7 V ≤ V _{DD} < 4.0 V	0.2		32	μs
			1.8 V ≤ V _{DD} < 2.7 V	0.4 ^{Note 1}		32	μs
External main system clock frequency	f _{EXCLK}	4.0 V ≤ V _{DD} ≤ 5.5 V	1.0		20.0	MHz	
		2.7 V ≤ V _{DD} < 4.0 V	1.0		10.0	MHz	
		1.8 V ≤ V _{DD} < 2.7 V	1.0		5.0	MHz	
External main system clock input high-level width, low-level width	t _{EXCLKH} , t _{EXCLKL}		(1/f _{EXCLK} × 1/2) - 1			ns	
TI000, TI010 input high-level width, low-level width	t _{TIH0} , t _{TIL0}	4.0 V ≤ V _{DD} ≤ 5.5 V	2/f _{sam} + 0.1 ^{Note 2}			μs	
		2.7 V ≤ V _{DD} < 4.0 V	2/f _{sam} + 0.2 ^{Note 2}			μs	
		1.8 V ≤ V _{DD} < 2.7 V	2/f _{sam} + 0.5 ^{Note 2}			μs	
TI50, TI51 input frequency	f _{TI5}	4.0 V ≤ V _{DD} ≤ 5.5 V			10	MHz	
		2.7 V ≤ V _{DD} < 4.0 V			10	MHz	
		1.8 V ≤ V _{DD} < 2.7 V			5	MHz	
TI50, TI51 input high-level width, low-level width	t _{TIH5} , t _{TIL5}	4.0 V ≤ V _{DD} ≤ 5.5 V	50			ns	
		2.7 V ≤ V _{DD} < 4.0 V	50			ns	
		1.8 V ≤ V _{DD} < 2.7 V	100			ns	
Interrupt input high-level width, low-level width	t _{INTH} , t _{INTL}		1			μs	
RESET low-level width	t _{RSL}		10			μs	

Notes 1. 0.38 μs when operating with the 8 MHz internal oscillator.

2. Selection of f_{sam} = f_{PRS}, f_{PRS}/4, f_{PRS}/256 is possible using bits 0 and 1 (PRM000, PRM001) of prescaler mode registers 00 (PRM00). Note that when selecting the TI000 valid edge as the count clock, f_{sam} = f_{PRS}.

T_{CY} vs. V_{DD} (Main System Clock Operation)

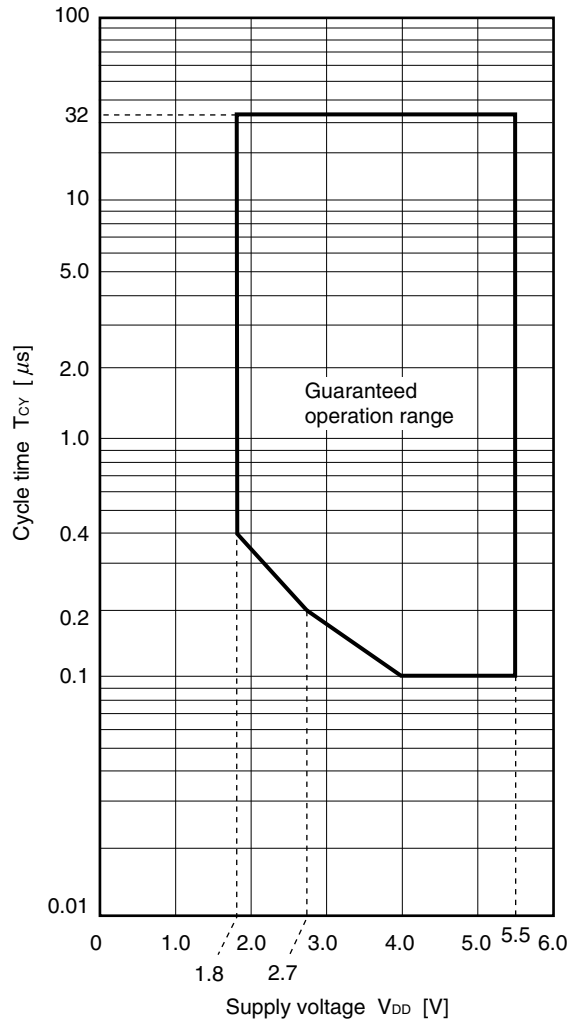

AC Timing Test Points (Excluding External Main System Clock)

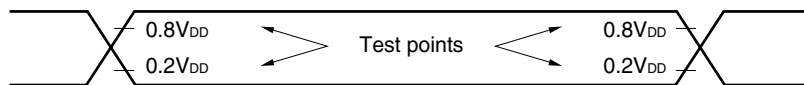

External Main System Clock Timing

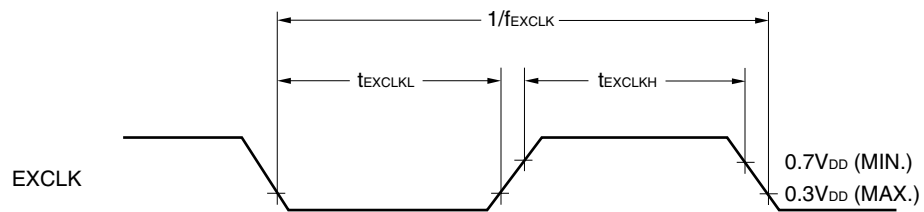

TI Timing

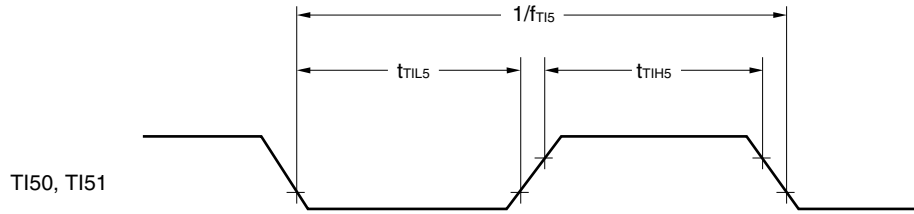
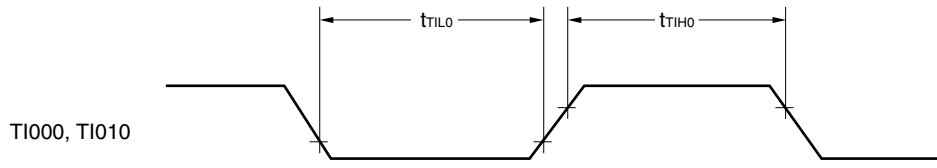

Interrupt Request Input Timing

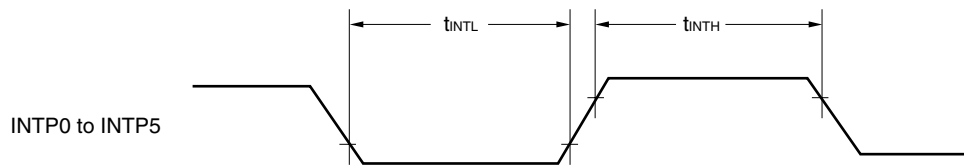

RESET Input Timing

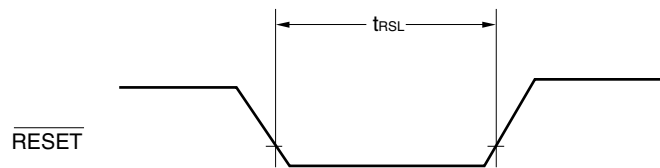

(2) Serial interface $(T_A = -40 \text{ to } +85^\circ\text{C}, 1.8 \text{ V} \leq V_{DD} = EV_{DD} \leq 5.5 \text{ V}, AV_{REF} \leq V_{DD}, V_{SS} = EV_{SS} = AV_{SS} = 0 \text{ V})$ **(a) UART6 (dedicated baud rate generator output)**

<R>

Parameter	Symbol	Conditions	MIN.	TYP.	MAX.	Unit
Transfer rate					625	kbps

(b) UART0 (dedicated baud rate generator output)

<R>

Parameter	Symbol	Conditions	MIN.	TYP.	MAX.	Unit
Transfer rate					625	kbps

(c) IIC0

Parameter	Symbol	Standard Mode		High-Speed Mode		Unit
		MIN.	MAX.	MIN.	MAX.	
SCL0 clock frequency	f_{SCL}	0	100	0	400	kHz
Setup time of start/restart condition ^{Note 1}	$t_{SU:STA}$	4.8	–	0.7	–	μs
Hold time	$t_{HD:STA}$	4.1	–	0.7	–	μs
Hold time when SCL0 = “L”	t_{LOW}	5.0	–	1.25	–	μs
Hold time when SCL0 = “H”	t_{HIGH}	5.0	–	1.25	–	μs
Data setup time (reception)	$t_{SU:DAT}$	0	–	0	–	μs
Data hold time (transmission) ^{Note 2}	$t_{HD:DAT}$	0.47	4.0	0.23	1.00	μs

Notes 1. The first clock pulse is generated after this period when the start/restart condition is detected.2. The maximum value (MAX.) of $t_{HD:DAT}$ is during normal transfer and a wait state is inserted in the ACK (acknowledge) timing.**(d) CSI10 (master mode, $\overline{\text{SCK10}}$... internal clock output)**

Parameter	Symbol	Conditions	MIN.	TYP.	MAX.	Unit
$\overline{\text{SCK10}}$ cycle time	t_{KCY1}	$4.0 \text{ V} \leq V_{DD} \leq 5.5 \text{ V}$	100			ns
		$2.7 \text{ V} \leq V_{DD} < 4.0 \text{ V}$	200			ns
		$1.8 \text{ V} \leq V_{DD} < 2.7 \text{ V}$	400			ns
$\overline{\text{SCK10}}$ high-/low-level width	$t_{KH1},$ t_{KL1}		$t_{KCY1}/2 -$ $10^{\text{Note 1}}$			ns
SI10 setup time (to $\overline{\text{SCK10}}\uparrow$)	t_{SIK1}		30			ns
SI10 hold time (from $\overline{\text{SCK10}}\uparrow$)	t_{KSI1}		30			ns
Delay time from $\overline{\text{SCK10}}\downarrow$ to SO10 output	t_{KSO1}	$C = 50 \text{ pF}^{\text{Note 2}}$			40	ns

Notes 1. This value is when high-speed system clock (f_{XH}) is used.2. C is the load capacitance of the $\overline{\text{SCK10}}$ and SO10 output lines.

(e) CSI10 (slave mode, SCK10... external clock input)

Parameter	Symbol	Conditions	MIN.	TYP.	MAX.	Unit
$\overline{\text{SCK10}}$ cycle time	t_{KCY2}		400			ns
$\overline{\text{SCK10}}$ high-/low-level width	t_{KH2} , t_{KL2}		$t_{\text{KCY2}}/2$			ns
SI10 setup time (to $\overline{\text{SCK10}}\uparrow$)	t_{SIK2}		80			ns
SI10 hold time (from $\overline{\text{SCK10}}\uparrow$)	t_{KSI2}		50			ns
Delay time from $\overline{\text{SCK10}}\downarrow$ to SO10 output	t_{KSO2}	$C = 50 \text{ pF}^{\text{Note}}$			120	ns

Note C is the load capacitance of the SO10 output line.

Serial Transfer Timing (1/2)

IIC0:

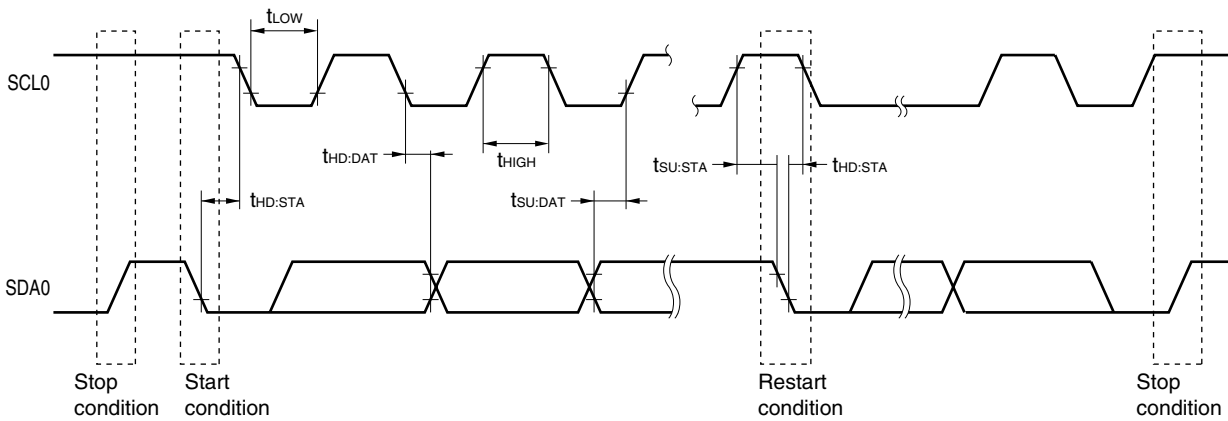

CSI10:

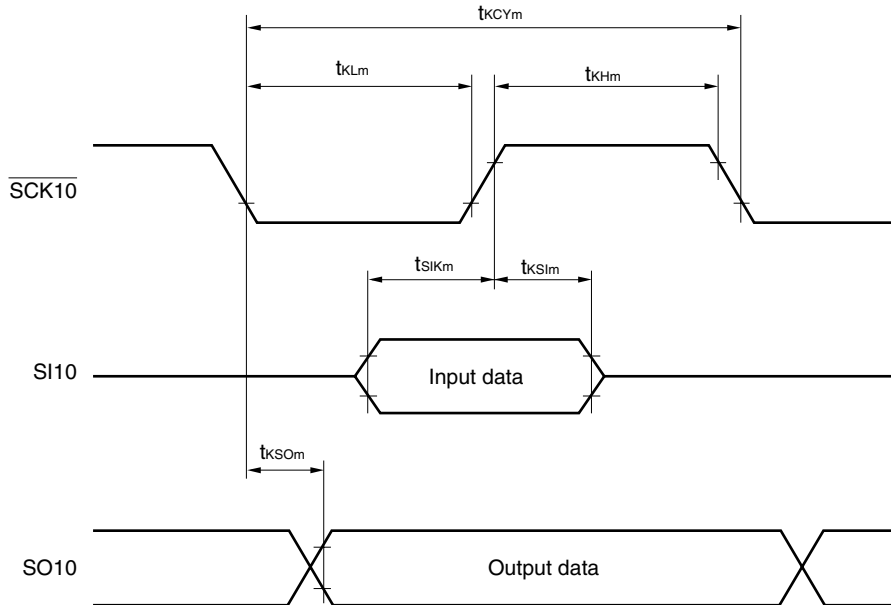

Remark $m = 1, 2$

A/D Converter Characteristics**($T_A = -40$ to $+85^\circ\text{C}$, $1.8\text{ V} \leq V_{DD} = EV_{DD} \leq 5.5\text{ V}$, $2.3\text{ V} \leq AV_{REF} \leq V_{DD}$, $V_{SS} = EV_{SS} = AV_{SS} = 0\text{ V}$)**

Parameter	Symbol	Conditions	MIN.	TYP.	MAX.	Unit
Resolution	R_{ES}				10	bit
Overall error ^{Notes 1, 2}	A_{INL}	$4.0\text{ V} \leq AV_{REF} \leq 5.5\text{ V}$			± 0.4	%FSR
		$2.7\text{ V} \leq AV_{REF} < 4.0\text{ V}$			± 0.6	%FSR
		$2.3\text{ V} \leq AV_{REF} < 2.7\text{ V}$			± 1.2	%FSR
Conversion time	t_{CONV}	$4.0\text{ V} \leq AV_{REF} \leq 5.5\text{ V}$	6.1		36.7	μs
		$2.7\text{ V} \leq AV_{REF} < 4.0\text{ V}$	12.2		36.7	μs
		$2.3\text{ V} \leq AV_{REF} < 2.7\text{ V}$	27		66.6	μs
Zero-scale error ^{Notes 1, 2}	E_{ZS}	$4.0\text{ V} \leq AV_{REF} \leq 5.5\text{ V}$			± 0.4	%FSR
		$2.7\text{ V} \leq AV_{REF} < 4.0\text{ V}$			± 0.6	%FSR
		$2.3\text{ V} \leq AV_{REF} < 2.7\text{ V}$			± 0.6	%FSR
Full-scale error ^{Notes 1, 2}	E_{FS}	$4.0\text{ V} \leq AV_{REF} \leq 5.5\text{ V}$			± 0.4	%FSR
		$2.7\text{ V} \leq AV_{REF} < 4.0\text{ V}$			± 0.6	%FSR
		$2.3\text{ V} \leq AV_{REF} < 2.7\text{ V}$			± 0.6	%FSR
Integral non-linearity error ^{Note 1}	I_{LE}	$4.0\text{ V} \leq AV_{REF} \leq 5.5\text{ V}$			± 2.5	LSB
		$2.7\text{ V} \leq AV_{REF} < 4.0\text{ V}$			± 4.5	LSB
		$2.3\text{ V} \leq AV_{REF} < 2.7\text{ V}$			± 6.5	LSB
Differential non-linearity error ^{Note 1}	D_{LE}	$4.0\text{ V} \leq AV_{REF} \leq 5.5\text{ V}$			± 1.5	LSB
		$2.7\text{ V} \leq AV_{REF} < 4.0\text{ V}$			± 2.0	LSB
		$2.3\text{ V} \leq AV_{REF} < 2.7\text{ V}$			± 2.0	%FSR
Analog input voltage	V_{AIN}		AV_{SS}		AV_{REF}	V

Notes 1. Excludes quantization error ($\pm 1/2$ LSB).

2. This value is indicated as a ratio (%FSR) to the full-scale value.

1.59 V POC Circuit Characteristics ($T_A = -40$ to $+85^\circ\text{C}$, $V_{SS} = EV_{SS} = 0\text{ V}$)

Parameter	Symbol	Conditions	MIN.	TYP.	MAX.	Unit
Detection voltage	V_{POC}		1.44	1.59	1.74	V
<R> Power voltage rise inclination	t_{PTH}	$V_{DD}: 0\text{ V} \rightarrow$ change inclination of V_{POC}	0.5			V/ms
Minimum pulse width	t_{PW}		200			μs

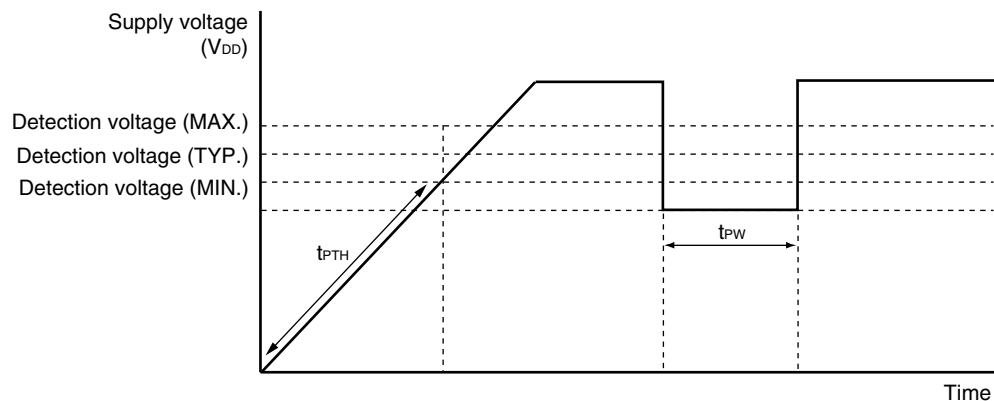
POC Circuit Timing

Supply Voltage Rise Time ($T_A = -40$ to $+85^\circ\text{C}$, $V_{SS} = EV_{SS} = 0\text{ V}$)

Parameter	Symbol	Conditions	MIN.	TYP.	MAX.	Unit
Maximum time to rise to 1.8 V (V_{DD} (MIN.)) ($V_{DD}: 0\text{ V} \rightarrow 1.8\text{ V}$)	t_{PUP1}	POCMODE (option byte) = 0, when $\overline{\text{RESET}}$ input is not used			3.6	ms
Maximum time to rise to 1.8 V (V_{DD} (MIN.)) (releasing $\overline{\text{RESET}}$ input $\rightarrow V_{DD}: 1.8\text{ V}$)	t_{PUP2}	POCMODE (option byte) = 0, when $\overline{\text{RESET}}$ input is used			1.9	ms

Supply Voltage Rise Time Timing

- When $\overline{\text{RESET}}$ pin input is not used

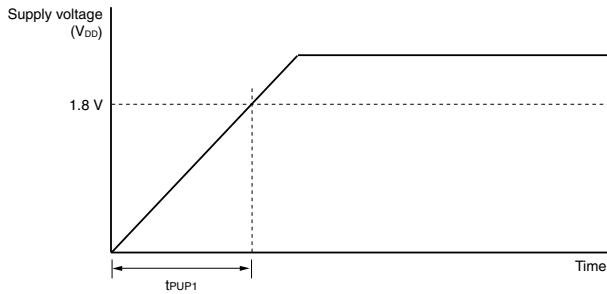

- When $\overline{\text{RESET}}$ pin input is used

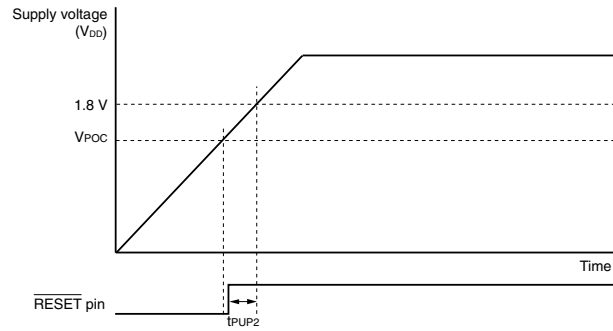

2.7 V POC Circuit Characteristics ($T_A = -40$ to $+85^\circ\text{C}$, $V_{SS} = EV_{SS} = 0\text{ V}$)

Parameter	Symbol	Conditions	MIN.	TYP.	MAX.	Unit
Detection voltage on application of supply voltage	V_{DDPOC}	POCMODE (option byte) = 1	2.50	2.70	2.90	V

LVI Circuit Characteristics ($T_A = -40$ to $+85^\circ\text{C}$, $V_{POC} \leq V_{DD} = EV_{DD} \leq 5.5$ V, $AV_{REF} \leq V_{DD}$, $V_{SS} = EV_{SS} = 0$ V)

Parameter	Symbol	Conditions	MIN.	TYP.	MAX.	Unit	
Detection voltage	Supply voltage level	V_{LV10}		4.14	4.24	4.34	V
		V_{LV11}		3.99	4.09	4.19	V
		V_{LV12}		3.83	3.93	4.03	V
		V_{LV13}		3.68	3.78	3.88	V
		V_{LV14}		3.52	3.62	3.72	V
		V_{LV15}		3.37	3.47	3.57	V
		V_{LV16}		3.22	3.32	3.42	V
		V_{LV17}		3.06	3.16	3.26	V
		V_{LV18}		2.91	3.01	3.11	V
		V_{LV19}		2.75	2.85	2.95	V
		V_{LV10}		2.60	2.70	2.80	V
		V_{LV11}		2.45	2.55	2.65	V
		V_{LV12}		2.29	2.39	2.49	V
		V_{LV13}		2.14	2.24	2.34	V
		V_{LV14}		1.98	2.08	2.18	V
		V_{LV15}		1.83	1.93	2.03	V
External input pin ^{Note 1}	EXLVI	$EXLVI < V_{DD}$, $1.8\text{ V} \leq V_{DD} \leq 5.5\text{ V}$	1.11	1.21	1.31	V	
Minimum pulse width	t_{LW}		200			μs	
Operation stabilization wait time ^{Note 2}	t_{LWAIT}				10	μs	

<R>

Notes 1. The EXLVI/P120/INTP0 pin is used.

2. Time required from setting bit 7 (LVION) of the low-voltage detection register (LVIM) to 1 to operation stabilization

Remark $V_{LV(n-1)} > V_{LVn}$; $n = 1$ to 15

LVI Circuit Timing

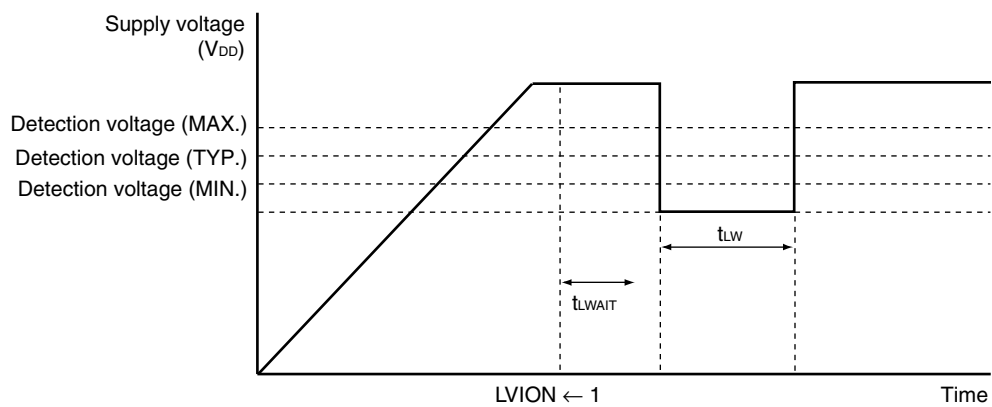

Data Memory STOP Mode Low Supply Voltage Data Retention Characteristics (T_A = -40 to +85°C)

Parameter	Symbol	Conditions	MIN.	TYP.	MAX.	Unit
Data retention supply voltage	V _{DDDR}		1.44 ^{Note}		5.5	V

Note The value depends on the POC detection voltage. When the voltage drops, the data is retained until a POC reset is effected, but data is not retained when a POC reset is effected.

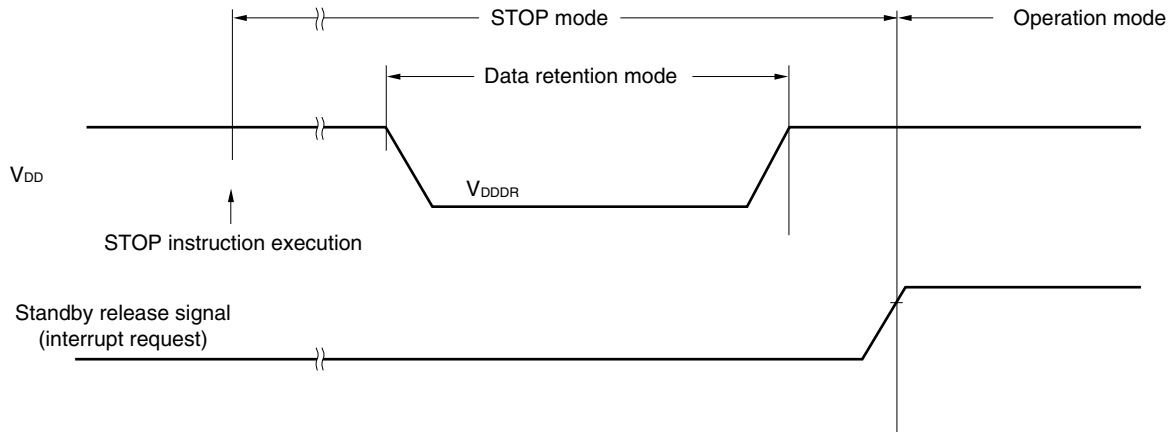

Flash Memory Programming Characteristics

(T_A = -40 to +85°C, 2.7 V ≤ V_{DD} = EV_{DD} ≤ 5.5 V, AV_{REF} ≤ V_{DD}, V_{SS} = EV_{SS} = AV_{SS} = 0 V)

• **Basic characteristics**

Parameter	Symbol	Conditions	MIN.	TYP.	MAX.	Unit
V _{DD} supply current	I _{DD}	f _{XP} = 10 MHz (TYP.), 20 MHz (MAX.)		4.5	11.0	mA
Erase time ^{Notes 1, 2}	All block	T _{eraca}		20	200	ms
	Block unit	T _{erasa}		20	200	ms
Write time (in 8-bit units) ^{Note 1}	T _{wrwa}			10	100	μs
Number of rewrites per chip	C _{erwr}	Retention: 10 years 1 erase + 1 write after erase = 1 rewrite ^{Note 3}	100			Times

- <R> **Notes**
1. Characteristic of the flash memory. For the characteristic when a dedicated flash memory programmer, PG-FP4, is used and the rewrite time during self programming, see **Tables 21-12** and **21-13**.
 2. The prewrite time before erasure and the erase verify time (writeback time) are not included.
 3. When a product is first written after shipment, “erase → write” and “write only” are both taken as one rewrite.

Remarks 1. f_{XP}: Main system clock oscillation frequency

- <R> 2. For serial write operation characteristics, refer to **78K0/Kx2 Flash Memory Programming (Programmer) Application Note (U17739E)**.

CHAPTER 25 ELECTRICAL SPECIFICATIONS ((A) GRADE PRODUCTS, TARGET)

Target products: μ PD78F0500(A), 78F0501(A), 78F0502(A), 78F0503(A)

Absolute Maximum Ratings ($T_A = 25^\circ\text{C}$) (1/2)

Parameter	Symbol	Conditions		Ratings	Unit
Supply voltage	V_{DD}			-0.5 to +6.5	V
	V_{SS}			-0.5 to +0.3	V
	AV_{REF}			-0.5 to $V_{DD} + 0.3^{\text{Note}}$	V
	AV_{SS}			-0.5 to +0.3	V
Input voltage	V_{I1}	P00, P01, P10 to P17, P20 to P23, P30 to P33, P120 to P122, X1, X2, RESET		-0.3 to $V_{DD} + 0.3^{\text{Note}}$	V
	V_{I2}	P60, P61 (N-ch open drain)		-0.3 to +6.5	V
Output voltage	V_O			-0.3 to $V_{DD} + 0.3^{\text{Note}}$	V
Analog input voltage	V_{AN}	ANI0 to ANI3		-0.3 to $AV_{REF} + 0.3^{\text{Note}}$ and -0.3 to $V_{DD} + 0.3^{\text{Note}}$	V
Output current, high	I_{OH}	Per pin	P00, P01, P10 to P17, P30 to P33, P120	-10	mA
		Total of all pins -80 mA	P00, P01, P120	-25	mA
			P10 to P17, P30 to P33	-55	mA
		Per pin	P20 to P23	-0.5	mA
		Total of all pins		-2	mA
		Per pin	P121, P122	-1	mA
Total of all pins	-4	mA			

Note Must be 6.5 V or lower.

Caution Product quality may suffer if the absolute maximum rating is exceeded even momentarily for any parameter. That is, the absolute maximum ratings are rated values at which the product is on the verge of suffering physical damage, and therefore the product must be used under conditions that ensure that the absolute maximum ratings are not exceeded.

Remark Unless specified otherwise, the characteristics of alternate-function pins are the same as those of port pins.

Absolute Maximum Ratings (T_A = 25°C) (2/2)

Parameter	Symbol	Conditions		Ratings	Unit
Output current, low	I _{OL}	Per pin	P00, P01, P10 to P17, P30 to P33, P60, P61, P120	30	mA
		Total of all pins 200 mA	P00, P01, P120	60	mA
			P10 to P17, P30 to P33, P60, P61	140	mA
		Per pin	P20 to P23	1	mA
		Total of all pins		5	mA
		Per pin	P121, P122	4	mA
		Total of all pins		10	mA
Operating ambient temperature	T _A	In normal operation mode		-40 to +85	°C
		In flash memory programming mode			
Storage temperature	T _{stg}			-65 to +150	°C

Caution Product quality may suffer if the absolute maximum rating is exceeded even momentarily for any parameter. That is, the absolute maximum ratings are rated values at which the product is on the verge of suffering physical damage, and therefore the product must be used under conditions that ensure that the absolute maximum ratings are not exceeded.

Remark Unless specified otherwise, the characteristics of alternate-function pins are the same as those of port pins.

X1 Oscillator Characteristics(T_A = -40 to +85°C, 1.8 V ≤ V_{DD} ≤ 5.5 V, V_{SS} = AV_{SS} = 0 V)

Resonator	Recommended Circuit	Parameter	Conditions	MIN.	TYP.	MAX.	Unit
Ceramic resonator		X1 clock oscillation frequency (f _x) ^{Note}	4.0 V ≤ V _{DD} ≤ 5.5 V	1.0		20.0	MHz
			2.7 V ≤ V _{DD} < 4.0 V	1.0		10.0	
			1.8 V ≤ V _{DD} < 2.7 V	1.0		5.0	
Crystal resonator		X1 clock oscillation frequency (f _x) ^{Note}	4.0 V ≤ V _{DD} ≤ 5.5 V	1.0		20.0	MHz
			2.7 V ≤ V _{DD} < 4.0 V	1.0		10.0	
			1.8 V ≤ V _{DD} < 2.7 V	1.0		5.0	

Note Indicates only oscillator characteristics. Refer to **AC Characteristics** for instruction execution time.

Cautions 1. When using the X1 oscillator, wire as follows in the area enclosed by the broken lines in the above figures to avoid an adverse effect from wiring capacitance.

- Keep the wiring length as short as possible.
 - Do not cross the wiring with the other signal lines.
 - Do not route the wiring near a signal line through which a high fluctuating current flows.
 - Always make the ground point of the oscillator capacitor the same potential as V_{SS}.
 - Do not ground the capacitor to a ground pattern through which a high current flows.
 - Do not fetch signals from the oscillator.
2. Since the CPU is started by the internal high-speed oscillation clock after a reset release, check the X1 clock oscillation stabilization time using the oscillation stabilization time counter status register (OSTC) by the user. Determine the oscillation stabilization time of the OSTC register and oscillation stabilization time select register (OSTS) after sufficiently evaluating the oscillation stabilization time with the resonator to be used.

Remark For the resonator selection and oscillator constant, customers are requested to either evaluate the oscillation themselves or apply to the resonator manufacturer for evaluation.

Internal Oscillator Characteristics**($T_A = -40$ to $+85^\circ\text{C}$, $1.8\text{ V} \leq V_{DD} \leq 5.5\text{ V}$, $V_{SS} = AV_{SS} = 0\text{ V}$)**

Resonator	Parameter	Conditions	MIN.	TYP.	MAX.	Unit	
8 MHz internal oscillator	Internal high-speed oscillation clock frequency (f_{RH}) ^{Note}	RSTS = 1	$2.7\text{ V} \leq V_{DD} \leq 5.5\text{ V}$	7.6	8.0	8.4	MHz
			$1.8\text{ V} \leq V_{DD} < 2.7\text{ V}$	7.6	8.0	10.4	MHz
		RSTS = 0		2.48	5	9.86	MHz
240 kHz internal oscillator	Internal low-speed oscillation clock frequency (f_{RL})		$2.7\text{ V} \leq V_{DD} \leq 5.5\text{ V}$	216	240	264	kHz
			$1.8\text{ V} \leq V_{DD} < 2.7\text{ V}$	192	240	264	kHz

Note Indicates only oscillator characteristics. Refer to **AC Characteristics** for instruction execution time.

Remark RSTS: Bit 7 of the internal oscillation mode register (RCM))

DC Characteristics (1/4)

(T_A = -40 to +85°C, 1.8 V ≤ V_{DD} ≤ 5.5 V, AV_{REF} ≤ V_{DD}, V_{SS} = AV_{SS} = 0 V)

Parameter	Symbol	Conditions	MIN.	TYP.	MAX.	Unit
Output current, high ^{Note 1}	IOH1	Per pin for P00, P01, P10 to P17, P30 to P33, P120	4.0 V ≤ V _{DD} ≤ 5.5 V		-3.0	mA
			2.7 V ≤ V _{DD} < 4.0 V		-2.5	mA
			1.8 V ≤ V _{DD} < 2.7 V		-1.0	mA
		Total of pins ^{Note 3} P00, P01, P120	4.0 V ≤ V _{DD} ≤ 5.5 V		-12.0	mA
			2.7 V ≤ V _{DD} < 4.0 V		-7.0	mA
			1.8 V ≤ V _{DD} < 2.7 V		-5.0	mA
		Total of pins ^{Note 3} P10 to P17, P30 to P33	4.0 V ≤ V _{DD} ≤ 5.5 V		-18.0	mA
			2.7 V ≤ V _{DD} < 4.0 V		-15.0	mA
			1.8 V ≤ V _{DD} < 2.7 V		-10.0	mA
	Total of all pins ^{Note 3}	4.0 V ≤ V _{DD} ≤ 5.5 V		-23.0	mA	
		2.7 V ≤ V _{DD} < 4.0 V		-20.0	mA	
		1.8 V ≤ V _{DD} < 2.7 V		-15.0	mA	
	IOH2	Per pin for P20 to P23	AV _{REF} = V _{DD}		-0.1	mA
			Per pin for P121, P122		-0.1	mA
	Output current, low ^{Note 2}	IOL1	Per pin for P00, P01, P10 to P17, P30 to P33, P120	4.0 V ≤ V _{DD} ≤ 5.5 V		8.5
2.7 V ≤ V _{DD} < 4.0 V					5.0	mA
1.8 V ≤ V _{DD} < 2.7 V					2.0	mA
Per pin for P60, P61			4.0 V ≤ V _{DD} ≤ 5.5 V		15.0	mA
			2.7 V ≤ V _{DD} < 4.0 V		5.0	mA
			1.8 V ≤ V _{DD} < 2.7 V		2.0	mA
Total of pins ^{Note 3} P00, P01, P120,			4.0 V ≤ V _{DD} ≤ 5.5 V		20.0	mA
			2.7 V ≤ V _{DD} < 4.0 V		15.0	mA
			1.8 V ≤ V _{DD} < 2.7 V		9.0	mA
Total of pins ^{Note 3} P10 to P17, P30 to P33, P60, P61		4.0 V ≤ V _{DD} ≤ 5.5 V		45.0	mA	
		2.7 V ≤ V _{DD} < 4.0 V		35.0	mA	
		1.8 V ≤ V _{DD} < 2.7 V		20.0	mA	
Total of all pins ^{Note 3}		4.0 V ≤ V _{DD} ≤ 5.5 V		65.0	mA	
		2.7 V ≤ V _{DD} < 4.0 V		50.0	mA	
		1.8 V ≤ V _{DD} < 2.7 V		29.0	mA	
IOL2		Per pin for P20 to P23	AV _{REF} = V _{DD}		0.4	mA
			Per pin for P121, 122		0.4	mA

Notes 1. Value of current at which the device operation is guaranteed even if the current flows from V_{DD} to an output pin.

2. Value of current at which the device operation is guaranteed even if the current flows from an output pin to GND.

3. Specification under conditions where the duty factor is 70% (time for which current is output is 0.7 × t and time for which current is not output is 0.3 × t, where t is a specific time). The total output current of the pins at a duty factor of other than 70% can be calculated by the following expression.

- Where the duty factor of I_{OH} is n%: Total output current of pins = (I_{OH} × 0.7) / (n × 0.01)

<Example> Where the duty factor is 50%, I_{OH} = 20.0 mA

$$\text{Total output current of pins} = (20.0 \times 0.7) / (50 \times 0.01) = 28.0 \text{ mA}$$

However, the current that is allowed to flow into one pin does not vary depending on the duty factor. A current higher than the absolute maximum rating must not flow into one pin.

Remark Unless specified otherwise, the characteristics of alternate-function pins are the same as those of port pins.

DC Characteristics (2/4)

(T_A = -40 to +85°C, 1.8 V ≤ V_{DD} ≤ 5.5 V, AV_{REF} ≤ V_{DD}, V_{SS} = AV_{SS} = 0 V)

Parameter	Symbol	Conditions	MIN.	TYP.	MAX.	Unit
Input voltage, high	V _{IH1}	P12, P13, P15, P121, P121	0.7V _{DD}		V _{DD}	V
	V _{IH2}	P00, P01, P10, P11, P14, P16, P17, P30 to P33, P120, RESET	0.8V _{DD}		V _{DD}	V
	V _{IH3}	P20 to P23	AV _{REF} = V _{DD}		AV _{REF}	V
	V _{IH4}	P60, P61			6.0	V
Input voltage, low	V _{IL1}	P12, P13, P15, P60, P61, P121, P122	0		0.3V _{DD}	V
	V _{IL2}	P00, P01, P10, P11, P14, P16, P17, P30 to P33, P120, RESET	0		0.2V _{DD}	V
	V _{IL3}	P20 to P23	AV _{REF} = V _{DD}		0.3AV _{REF}	V
Output voltage, high	V _{OH1}	P00, P01, P10 to P17, P30 to P33, P120	4.0 V ≤ V _{DD} ≤ 5.5 V, I _{OH1} = -3.0 mA		V _{DD} - 0.7	V
			2.7 V ≤ V _{DD} < 4.0 V, I _{OH1} = -2.5 mA		V _{DD} - 0.5	V
			1.8 V ≤ V _{DD} < 2.7 V, I _{OH1} = -1.0 mA		V _{DD} - 0.5	V
	V _{OH2}	P20 to P23 P121, P122	AV _{REF} = V _{DD} , I _{OH2} = -100 μA		V _{DD} - 0.5	V
			I _{OH2} = -100 μA		V _{DD} - 0.5	V
Output voltage, low	V _{OL1}	P00, P01, P10 to P17, P30 to P33, P120	4.0 V ≤ V _{DD} ≤ 5.5 V, I _{OL1} = 8.5 mA		0.7	V
			2.7 V ≤ V _{DD} < 4.0 V, I _{OL1} = 5.0 mA		0.7	V
			1.8 V ≤ V _{DD} < 2.7 V, I _{OL1} = 2.0 mA		0.5	V
			1.8 V ≤ V _{DD} < 2.7 V, I _{OL1} = 0.5 mA		0.4	V
	V _{OL2}	P20 to P23 P121, P122	AV _{REF} = V _{DD} , I _{OL2} = 0.4 mA		0.4	V
			I _{OL2} = 0.4 mA		0.4	V
	V _{OL3}	P60, P61	4.0 V ≤ V _{DD} ≤ 5.5 V, I _{OL1} = 15.0 mA		2.0	V
			4.0 V ≤ V _{DD} ≤ 5.5 V, I _{OL1} = 5.0 mA		0.4	V
			2.7 V ≤ V _{DD} < 4.0 V, I _{OL1} = 5.0 mA		0.6	V
			2.7 V ≤ V _{DD} < 4.0 V, I _{OL1} = 3.0 mA		0.4	V
1.8 V ≤ V _{DD} < 2.7 V, I _{OL1} = 2.0 mA				0.4	V	

Remark Unless specified otherwise, the characteristics of alternate-function pins are the same as those of port pins.

DC Characteristics (3/4)

(T_A = -40 to +85°C, 1.8 V ≤ V_{DD} ≤ 5.5 V, AV_{REF} ≤ V_{DD}, V_{SS} = AV_{SS} = 0 V)

Parameter	Symbol	Conditions		MIN.	TYP.	MAX.	Unit
Input leakage current, high	I _{LIH1}	P00, P01, P10 to P17, P30 to P33, P120	V _I = V _{DD}			1	μA
	I _{LIH2}	P20 to P23	V _I = AV _{REF} = V _{DD}			1	μA
	I _{LIH3}	P121, 122 (X1, X2)	V _I = V _{DD}	I/O port mode			1
OSC mode						20	μA
Input leakage current, low	I _{LIL1}	P00, P01, P10 to P17, P30 to P33, P60, P61, P120	V _I = V _{SS}			-1	μA
	I _{LIL2}	P20 to P23	V _I = V _{SS} , AV _{REF} = V _{DD}			-1	μA
	I _{LIL3}	P121, P122 (X1, X2)	V _I = V _{SS}	I/O port mode			-1
OSC mode						-20	μA
Pull-up resistor	R _U	V _I = V _{DD}		10	20	100	kΩ
FLMD0 supply voltage	V _{IL}	In normal operation mode		0		0.2V _{DD}	V
	V _{IH}	In self-programming mode		0.8V _{DD}		V _{DD}	V
External clock input voltage	V _{IL}	P122	In external clock input mode	0		0.2V _{DD}	V
	V _{IH}			0.8V _{DD}		V _{DD}	V

Remark Unless specified otherwise, the characteristics of alternate-function pins are the same as those of port pins.

DC Characteristics (4/4)

(T_A = -40 to +85°C, 1.8 V ≤ V_{DD} ≤ 5.5 V, AV_{REF} ≤ V_{DD}, V_{SS} = AV_{SS} = 0 V)

Parameter	Symbol	Conditions		MIN.	TYP.	MAX.	Unit	
Supply current	I _{DD1} ^{Note 1}	Operating mode	f _{XH} = 20 MHz ^{Note 2} , V _{DD} = 5.0 V	Square wave input		3.2	5.5	mA
				Resonator connection		4.5	6.9	
			f _{XH} = 10 MHz ^{Notes 2, 3} , V _{DD} = 5.0 V	Square wave input		1.6	2.8	mA
				Resonator connection		2.3	3.9	
			f _{XH} = 10 MHz ^{Notes 2, 3} , V _{DD} = 3.0 V	Square wave input		1.5	2.7	mA
				Resonator connection		2.2	3.2	
			f _{XH} = 5 MHz ^{Notes 2, 3} , V _{DD} = 3.0 V	Square wave input		0.9	1.6	mA
	Resonator connection			1.3	2.0			
	f _{XH} = 5 MHz ^{Notes 2, 3} , V _{DD} = 2.0 V	Square wave input		0.7	1.4	mA		
		Resonator connection		1.0	1.6			
	I _{DD2} ^{Note 4}	HALT mode	f _{XH} = 20 MHz ^{Note 2} , V _{DD} = 5.0 V	Square wave input		0.8	2.6	mA
				Resonator connection		2.0	4.4	
			f _{XH} = 10 MHz ^{Notes 2, 3} , V _{DD} = 5.0 V	Square wave input		0.4	1.3	mA
				Resonator connection		1.0	2.4	
f _{XH} = 5 MHz ^{Notes 2, 3} , V _{DD} = 3.0 V			Square wave input		0.2	0.65	mA	
			Resonator connection		0.5	1.1		
f _{RH} = 8 MHz, V _{DD} = 5.0 V				0.4	1.2	mA		
I _{DD3} ^{Note 4}	STOP mode	V _{DD} = 5.0 V			1	20	μA	
		V _{DD} = 5.0 V, T _A = -40 to +70°C			1	10	μA	
A/D converter operating current	I _{ADC} ^{Note 5}	During conversion at maximum speed	2.3 V ≤ AV _{REF} ≤ V _{DD}		0.86	1.9	mA	
		Not during conversion (comparator operation) ^{Note 6}			0.6	1.2	mA	
Watchdog timer operating current	I _{WDT} ^{Note 7}	During 240 kHz internal low-speed oscillation clock operation			5	10	μA	
LVI operating current	I _{LVI} ^{Note 8}				9	18	μA	

Remarks 1. f_{XH}: High-speed system clock frequency (X1 clock oscillation frequency or external main system clock frequency)

2. f_{RH}: Internal high-speed oscillation clock frequency

(Notes on next page)

- Notes**
1. Total current flowing into the internal power supply (V_{DD} , AV_{REF}), including the peripheral operation current (however, the current flowing into the pull-up resistors of the port, and A/D converter is not included).
 2. Not including the operating current of the internal high-speed clock (f_{RH})
 3. When AMPH (bit 0 of clock operation mode select register (OSCCTL)) = 0.
 4. Total current flowing into the internal power supply (V_{DD} , AV_{REF}), including the peripheral operating current (however, the current flowing into the pull-up resistor of the port, A/D converter, watchdog timer, and LVI circuit is not included)
 5. Current flowing only to the A/D converter. The current value of the 78K0/KB2 is the sum of I_{DD1} or I_{DD2} and I_{ADC} when the A/D converter operates in an operation mode or the HALT mode.
 6. Current when ADCE (bit 0 of A/D converter mode register (ADM)) = 1 and ADCS (bit 7 of ADM) = 0
 7. Current flowing only to the watchdog timer. The current value of the 78K0/KB2 is the sum of I_{DD2} or I_{DD3} and I_{WDT} when the watchdog timer operates in the HALT or STOP mode.
 8. Current flowing only to the LVI circuit. The current value of the 78K0/KB2 is the sum of I_{DD2} or I_{DD3} and I_{LVI} when the LVI circuit operates in the HALT or STOP mode.

AC Characteristics

(1) Basic operation

(T_A = -40 to +85°C, 1.8 V ≤ V_{DD} ≤ 5.5 V, AV_{REF} ≤ V_{DD}, V_{SS} = AV_{SS} = 0 V)

Parameter	Symbol	Conditions	MIN.	TYP.	MAX.	Unit	
Instruction cycle (minimum instruction execution time)	T _{CY}	Main system clock (f _{XP}) operation	4.0 V ≤ V _{DD} ≤ 5.5 V	0.1		32	μs
			2.7 V ≤ V _{DD} < 4.0 V	0.2		32	μs
			1.8 V ≤ V _{DD} < 2.7 V	0.4 ^{Note 1}		32	μs
External main system clock frequency	f _{EXCLK}	4.0 V ≤ V _{DD} ≤ 5.5 V	1.0		20.0	MHz	
		2.7 V ≤ V _{DD} < 4.0 V	1.0		10.0	MHz	
		1.8 V ≤ V _{DD} < 2.7 V	1.0		5.0	MHz	
External main system clock input high-level width, low-level width	t _{EXCLKH} , t _{EXCLKL}		(1/f _{EXCLK} × 1/2) - 1			ns	
TI000, TI010 input high-level width, low-level width	t _{TIH0} , t _{TIL0}	4.0 V ≤ V _{DD} ≤ 5.5 V	2/f _{sam} + 0.1 ^{Note 2}			μs	
		2.7 V ≤ V _{DD} < 4.0 V	2/f _{sam} + 0.2 ^{Note 2}			μs	
		1.8 V ≤ V _{DD} < 2.7 V	2/f _{sam} + 0.5 ^{Note 2}			μs	
TI50, TI51 input frequency	f _{TI5}	4.0 V ≤ V _{DD} ≤ 5.5 V			10	MHz	
		2.7 V ≤ V _{DD} < 4.0 V			10	MHz	
		1.8 V ≤ V _{DD} < 2.7 V			5	MHz	
TI50, TI51 input high-level width, low-level width	t _{TIH5} , t _{TIL5}	4.0 V ≤ V _{DD} ≤ 5.5 V	50			ns	
		2.7 V ≤ V _{DD} < 4.0 V	50			ns	
		1.8 V ≤ V _{DD} < 2.7 V	100			ns	
Interrupt input high-level width, low-level width	t _{INTH} , t _{INTL}		1			μs	
RESET low-level width	t _{RSL}		10			μs	

Notes 1. 0.38 μs when operating with the 8 MHz internal oscillator.

2. Selection of f_{sam} = f_{PRS}, f_{PRS}/4, f_{PRS}/256 is possible using bits 0 and 1 (PRM000, PRM001) of prescaler mode register 00 (PRM00). Note that when selecting the TI000 valid edge as the count clock, f_{sam} = f_{PRS}.

T_{CY} vs. V_{DD} (Main System Clock Operation)

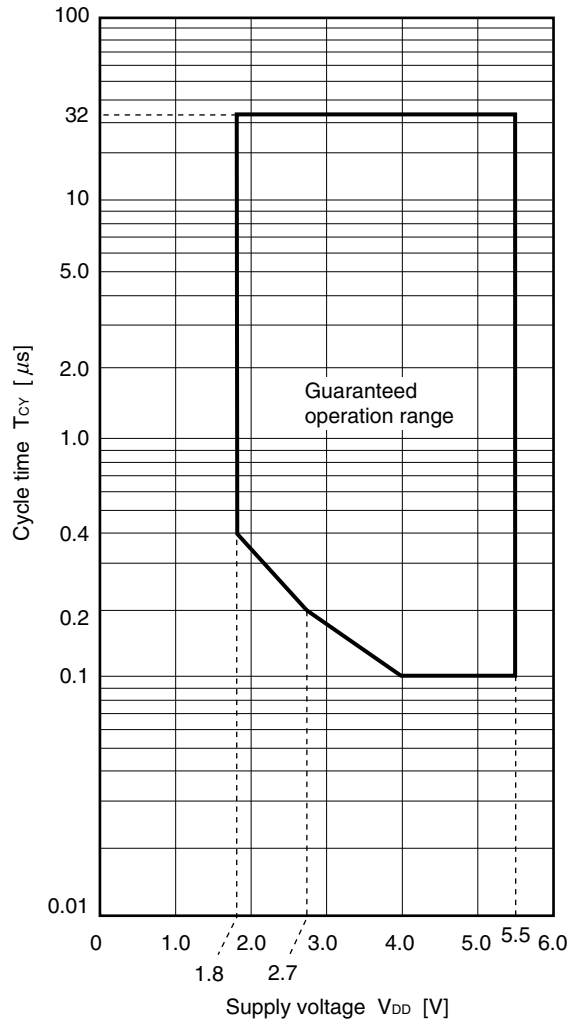

AC Timing Test Points (Excluding External Main System Clock and External Subsystem Clock)

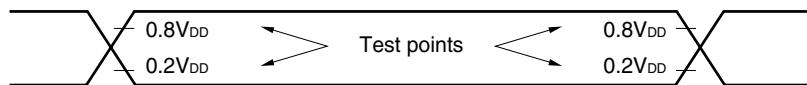

External Main System Clock Timing, External Subsystem Clock Timing

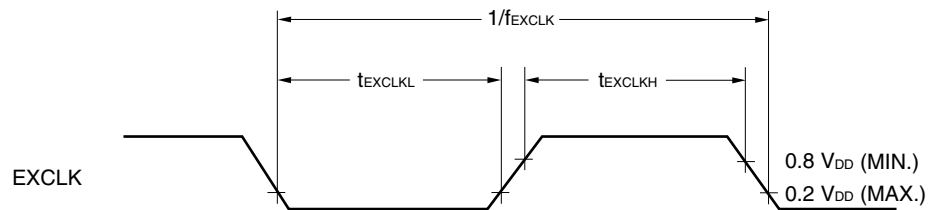

TI Timing

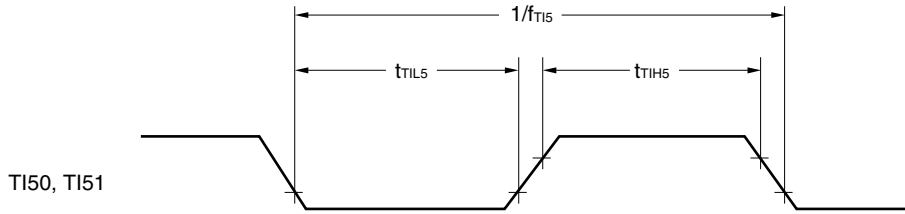
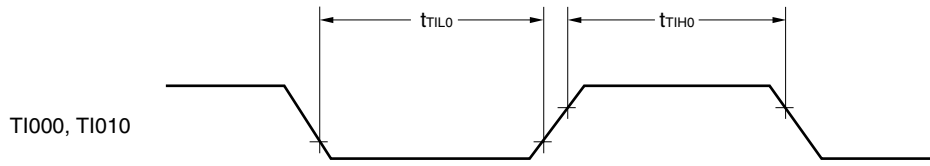

Interrupt Request Input Timing

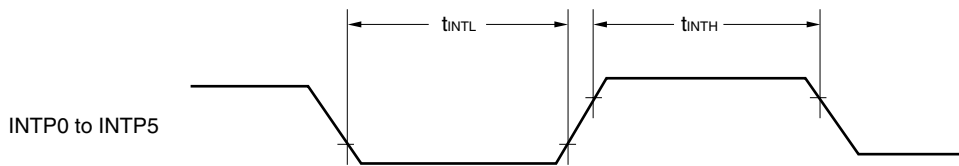

RESET Input Timing

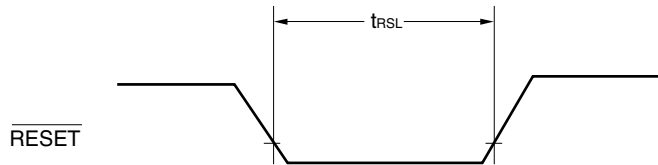

(2) Serial interface $(T_A = -40 \text{ to } +85^\circ\text{C}, 1.8 \text{ V} \leq V_{DD} \leq 5.5 \text{ V}, AV_{REF} \leq V_{DD}, V_{SS} = AV_{SS} = 0 \text{ V})$ **(a) UART6 (dedicated baud rate generator output)**

Parameter	Symbol	Conditions	MIN.	TYP.	MAX.	Unit
Transfer rate					625	kbps

(b) UART0 (dedicated baud rate generator output)

Parameter	Symbol	Conditions	MIN.	TYP.	MAX.	Unit
Transfer rate					625	kbps

(c) IIC0

Parameter	Symbol	Standard Mode		High-Speed Mode		Unit
		MIN.	MAX.	MIN.	MAX.	
SCL0 clock frequency	f_{SCL}	0	100	0	400	kHz
Setup time of start/restart condition ^{Note 1}	$t_{SU:STA}$	4.8	–	0.7	–	μs
Hold time	$t_{HD:STA}$	4.1	–	0.7	–	μs
Hold time when SCL0 = "L"	t_{LOW}	5.0	–	1.25	–	μs
Hold time when SCL0 = "H"	t_{HIGH}	5.0	–	1.25	–	μs
Data setup time (reception)	$t_{SU:DAT}$	0	–	0	–	μs
Data hold time (transmission) ^{Note 2}	$t_{HD:DAT}$	0.47	4.0	0.23	1.00	μs

Notes 1. The first clock pulse is generated after this period when the start/restart condition is detected.

2. The maximum value (MAX.) of $t_{HD:DAT}$ is during normal transfer and a wait state is inserted in the \overline{ACK} (acknowledge) timing.

(d) CSI10 (master mode, $\overline{\text{SCK10}}$... internal clock output)

Parameter	Symbol	Conditions	MIN.	TYP.	MAX.	Unit
$\overline{\text{SCK10}}$ cycle time	t_{KCY1}	$4.0 \text{ V} \leq V_{\text{DD}} \leq 5.5 \text{ V}$	100			ns
		$2.7 \text{ V} \leq V_{\text{DD}} < 4.0 \text{ V}$	200			ns
		$1.8 \text{ V} \leq V_{\text{DD}} < 2.7 \text{ V}$	400			ns
$\overline{\text{SCK10}}$ high-/low-level width	t_{KH1} , t_{KL1}		$t_{\text{KCY1}}/2 - 10^{\text{Note 1}}$			ns
SI10 setup time (to $\overline{\text{SCK10}}\uparrow$)	t_{SIK1}		30			ns
SI10 hold time (from $\overline{\text{SCK10}}\uparrow$)	t_{KSI1}		30			ns
Delay time from $\overline{\text{SCK10}}\downarrow$ to SO10 output	t_{KSO1}	$C = 50 \text{ pF}^{\text{Note 2}}$			40	ns

- Notes**
1. This value is when high-speed system clock (f_{XH}) is used.
 2. C is the load capacitance of the $\overline{\text{SCK10}}$ and SO10 output lines.

(e) CSI10 (slave mode, $\overline{\text{SCK10}}$... external clock input)

Parameter	Symbol	Conditions	MIN.	TYP.	MAX.	Unit
$\overline{\text{SCK10}}$ cycle time	t_{KCY2}		400			ns
$\overline{\text{SCK10}}$ high-/low-level width	t_{KH2} , t_{KL2}		$t_{\text{KCY2}}/2$			ns
SI10 setup time (to $\overline{\text{SCK10}}\uparrow$)	t_{SIK2}		80			ns
SI10 hold time (from $\overline{\text{SCK10}}\uparrow$)	t_{KSI2}		50			ns
Delay time from $\overline{\text{SCK10}}\downarrow$ to SO10 output	t_{KSO2}	$C = 50 \text{ pF}^{\text{Note}}$			120	ns

Note C is the load capacitance of the SO10 output line.

Serial Transfer Timing

IIC0:

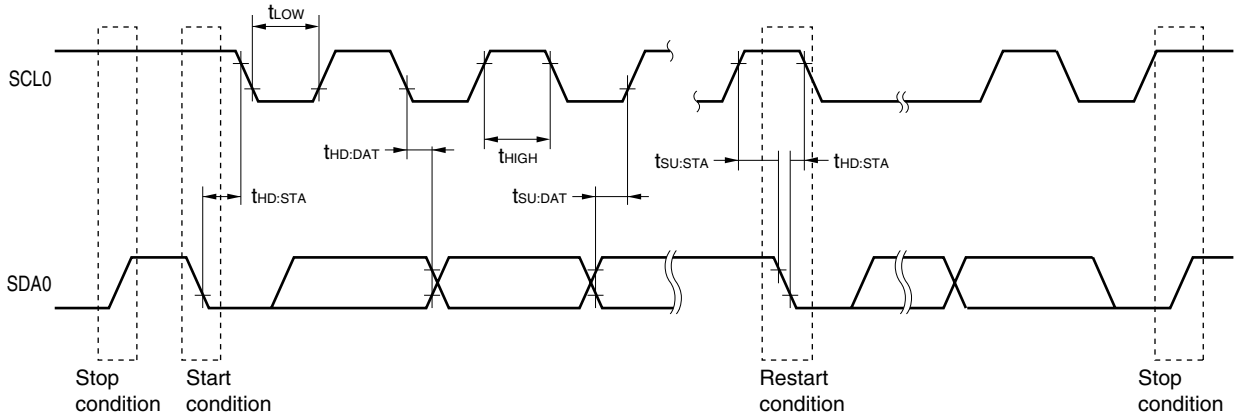

CSI10:

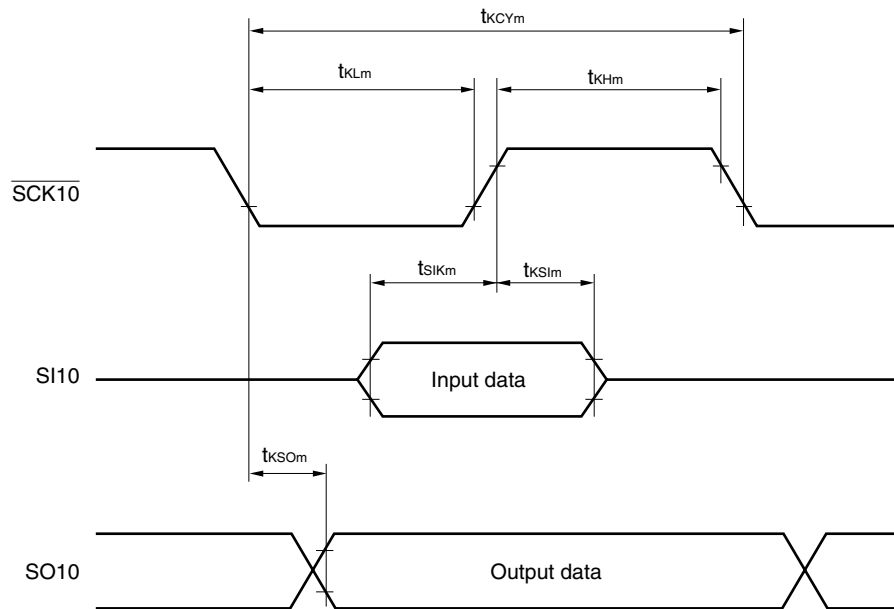

Remark $m = 1, 2$

A/D Converter Characteristics

 (T_A = -40 to +85°C, 1.8 V ≤ V_{DD} ≤ 5.5 V, AV_{REF} ≤ V_{DD}, V_{SS} = AV_{SS} = 0 V)

Parameter	Symbol	Conditions	MIN.	TYP.	MAX.	Unit
Resolution	RES				10	bit
Overall error ^{Notes 1, 2}	A _{INL}	4.0 V ≤ AV _{REF} ≤ 5.5 V			±0.4	%FSR
		2.7 V ≤ AV _{REF} < 4.0 V			±0.6	%FSR
		2.3 V ≤ AV _{REF} < 2.7 V			±1.2	%FSR
Conversion time	t _{CONV}	4.0 V ≤ AV _{REF} ≤ 5.5 V	6.1		36.7	μs
		2.7 V ≤ AV _{REF} < 4.0 V	12.2		36.7	μs
		2.3 V ≤ AV _{REF} < 2.7 V	27		66.6	μs
Zero-scale error ^{Notes 1, 2}	E _{ZS}	4.0 V ≤ AV _{REF} ≤ 5.5 V			±0.4	%FSR
		2.7 V ≤ AV _{REF} < 4.0 V			±0.6	%FSR
		2.3 V ≤ AV _{REF} < 2.7 V			±0.6	%FSR
Full-scale error ^{Notes 1, 2}	E _{FS}	4.0 V ≤ AV _{REF} ≤ 5.5 V			±0.4	%FSR
		2.7 V ≤ AV _{REF} < 4.0 V			±0.6	%FSR
		2.3 V ≤ AV _{REF} < 2.7 V			±0.6	%FSR
Integral non-linearity error ^{Note 1}	I _{LE}	4.0 V ≤ AV _{REF} ≤ 5.5 V			±2.5	LSB
		2.7 V ≤ AV _{REF} < 4.0 V			±4.5	LSB
		2.3 V ≤ AV _{REF} < 2.7 V			±6.5	LSB
Differential non-linearity error ^{Note 1}	D _{LE}	4.0 V ≤ AV _{REF} ≤ 5.5 V			±1.5	LSB
		2.7 V ≤ AV _{REF} < 4.0 V			±2.0	LSB
		2.3 V ≤ AV _{REF} < 2.7 V			±2.0	LSB
Analog input voltage	V _{AIN}		AV _{SS}		AV _{REF}	V

- Notes**
- Excludes quantization error (±1/2 LSB).
 - This value is indicated as a ratio (%FSR) to the full-scale value.

1.59 V POC Circuit Characteristics (T_A = -40 to +85°C, V_{SS} = 0 V)

Parameter	Symbol	Conditions	MIN.	TYP.	MAX.	Unit
Detection voltage	V _{POC}		1.44	1.59	1.74	V
Power voltage rise inclination	t _{PTH}	V _{DD} : 0 V → change inclination of V _{POC}	0.5			V/ms
Minimum pulse width	t _{PW}		200			μs

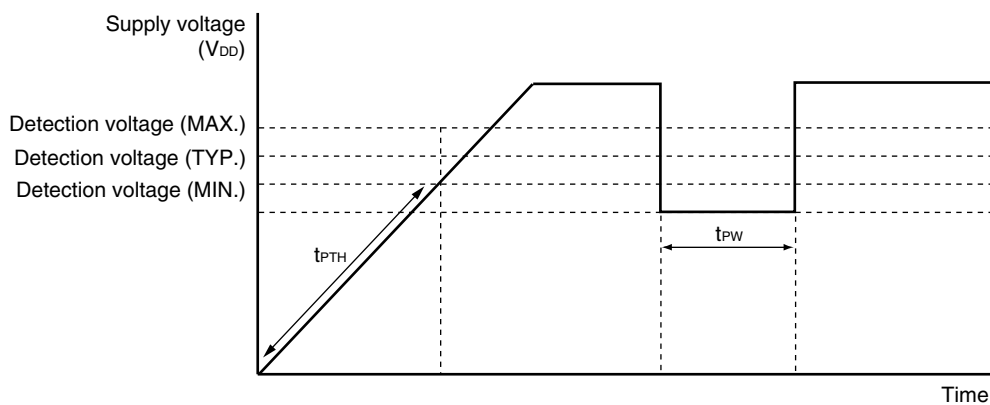
POC Circuit Timing

Supply Voltage Rise Time ($T_A = -40$ to $+85^\circ\text{C}$, $V_{SS} = 0$ V)

Parameter	Symbol	Conditions	MIN.	TYP.	MAX.	Unit
Maximum time to rise to 1.8 V (V_{DD} (MIN.)) ($V_{DD}: 0$ V \rightarrow 1.8 V)	t_{PUP1}	POCMODE (option byte) = 0, when $\overline{\text{RESET}}$ input is not used			3.6	ms
Maximum time to rise to 1.8 V (V_{DD} (MIN.)) (releasing $\overline{\text{RESET}}$ input \rightarrow $V_{DD}: 1.8$ V)	t_{PUP2}	POCMODE (option byte) = 0, when $\overline{\text{RESET}}$ input is used			1.9	ms

Supply Voltage Rise Time Timing

- When $\overline{\text{RESET}}$ pin input is not used

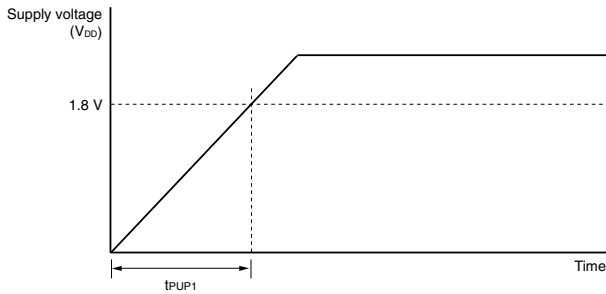

- When $\overline{\text{RESET}}$ pin input is used

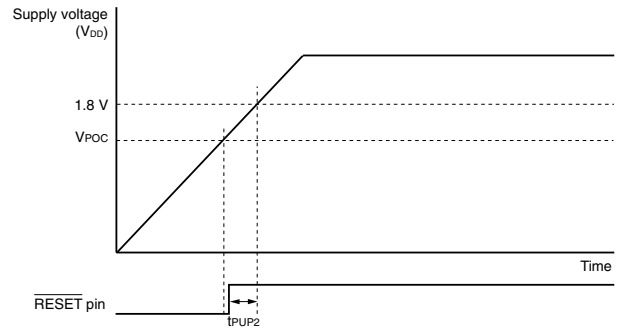

2.7 V POC Circuit Characteristics ($T_A = -40$ to $+85^\circ\text{C}$, $V_{SS} = 0$ V)

Parameter	Symbol	Conditions	MIN.	TYP.	MAX.	Unit
Detection voltage on application of supply voltage	V_{DDPOC}	POCMODE (option byte) = 1	2.50	2.70	2.90	V

LVI Circuit Characteristics ($T_A = -40$ to $+85^\circ\text{C}$, $V_{POC} \leq V_{DD} \leq 5.5$ V, $AV_{REF} \leq V_{DD}$, $V_{SS} = 0$ V)

Parameter	Symbol	Conditions	MIN.	TYP.	MAX.	Unit	
Detection voltage	Supply voltage level	V_{LVI0}		4.14	4.24	4.34	V
		V_{LVI1}		3.99	4.09	4.19	V
		V_{LVI2}		3.83	3.93	4.03	V
		V_{LVI3}		3.68	3.78	3.88	V
		V_{LVI4}		3.52	3.62	3.72	V
		V_{LVI5}		3.37	3.47	3.57	V
		V_{LVI6}		3.22	3.32	3.42	V
		V_{LVI7}		3.06	3.16	3.26	V
		V_{LVI8}		2.91	3.01	3.11	V
		V_{LVI9}		2.75	2.85	2.95	V
		V_{LVI10}		2.60	2.70	2.80	V
		V_{LVI11}		2.45	2.55	2.65	V
		V_{LVI12}		2.29	2.39	2.49	V
		V_{LVI13}		2.14	2.24	2.34	V
		V_{LVI14}		1.98	2.08	2.18	V
V_{LVI15}		1.83	1.93	2.03	V		
External input pin ^{Note 1}	EXLVI	$EXLVI < V_{DD}$, 1.8 V $\leq V_{DD} \leq 5.5$ V	1.11	1.21	1.31	V	
Minimum pulse width	t_{LW}		200			μs	
Operation stabilization wait time ^{Note 2}	t_{LWAIT}				10	μs	

Notes 1. The EXLVI/P120/INTP0 pin is used.

2. Time required from setting bit 7 (LVION) of the low-voltage detection register (LVIM) to 1 to operation stabilization

Remark $V_{LVI(n-1)} > V_{LVI n}$; $n = 1$ to 15

LVI Circuit Timing

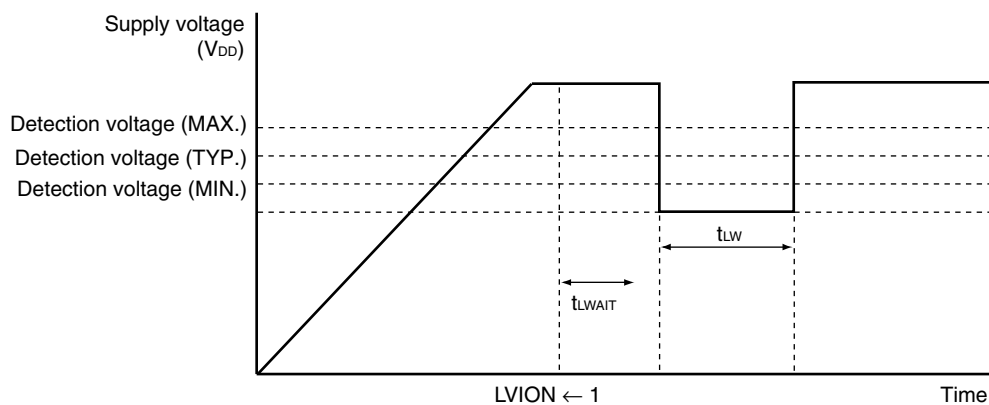

Data Memory STOP Mode Low Supply Voltage Data Retention Characteristics (T_A = -40 to +85°C)

Parameter	Symbol	Conditions	MIN.	TYP.	MAX.	Unit
Data retention supply voltage	V _{DDDR}		1.44 ^{Note}		5.5	V

Note The value depends on the POC detection voltage. When the voltage drops, the data is retained until a POC reset is effected, but data is not retained when a POC reset is effected.

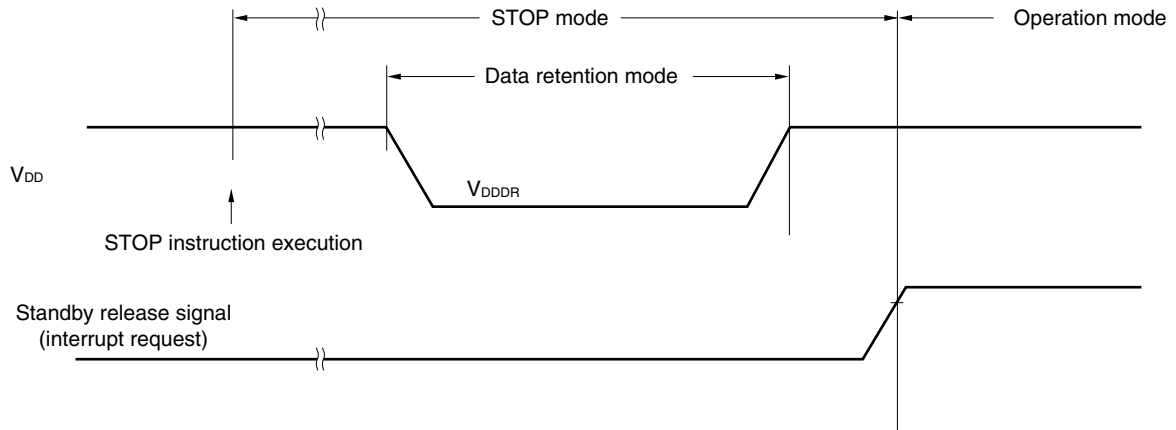
**Flash Memory Programming Characteristics**

(T_A = -40 to +85°C, 2.7 V ≤ V_{DD} ≤ 5.5 V, AV_{REF} ≤ V_{DD}, V_{SS} = AV_{SS} = 0 V)

• Basic characteristics

Parameter	Symbol	Conditions	MIN.	TYP.	MAX.	Unit
V _{DD} supply current	I _{DD}	f _{XP} = 10 MHz (TYP.), 20 MHz (MAX.)		4.5	11.0	mA
Erase time ^{Notes 1, 2}	All block	T _{eraca}		20	200	ms
	Block unit	T _{erasa}		20	200	ms
Write time (in 8-bit units) ^{Note 1}	T _{wrwa}			10	100	μs
Number of rewrites per chip	C _{erwr}	Retention: 10 years 1 erase + 1 write after erase = 1 rewrite ^{Note 3}	T.B.D.			Times

- Notes**
- Characteristic of the flash memory. For the characteristic when a dedicated flash memory programmer, PG-FP4, is used and the rewrite time during self programming, see **Tables 21-12** and **21-13**.
 - The prewrite time before erasure and the erase verify time (writeback time) are not included.
 - When a product is first written after shipment, “erase → write” and “write only” are both taken as one rewrite.

Remarks 1. f_{XP}: Main system clock oscillation frequency

- For serial write operation characteristics, refer to **78K0/Kx2 Flash Memory Programming (Programmer) Application Note (U17739E)**.

CHAPTER 26 PACKAGE DRAWING

- μ PD78F0500MC-5A4-A, 78F0501MC-5A4-A, 78F0502MC-5A4-A, 78F0503MC-5A4-A, 78F0503DMC-5A4-A

30-PIN PLASTIC SSOP (7.62 mm (300))

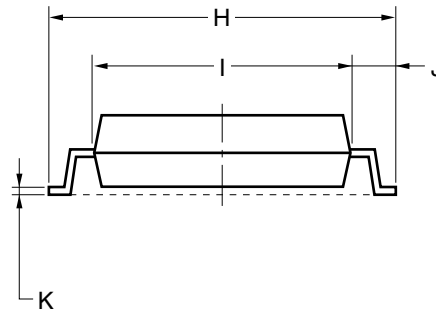
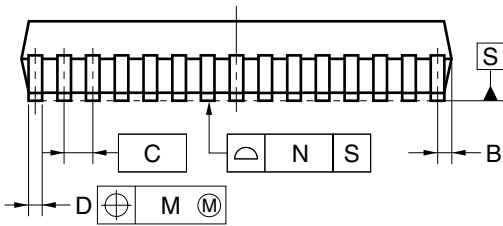
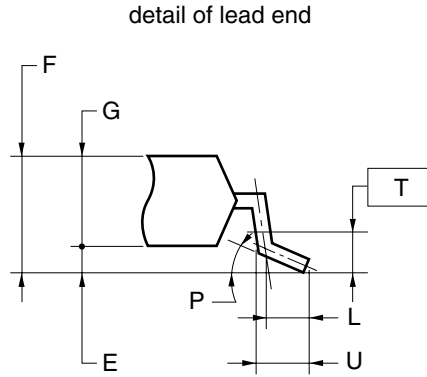
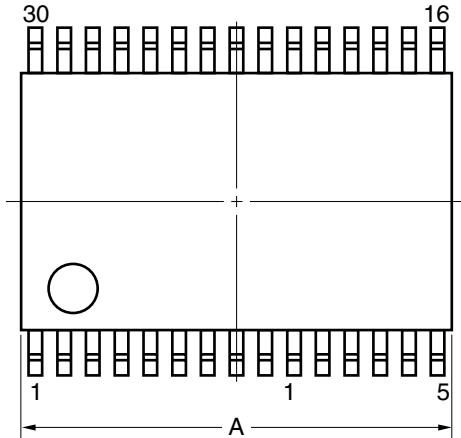

NOTE

Each lead centerline is located within 0.13 mm of its true position (T.P.) at maximum material condition.

ITEM	MILLIMETERS
A	9.85±0.15
B	0.45 MAX.
C	0.65 (T.P.)
D	0.24 ^{+0.08} _{-0.07}
E	0.1±0.05
F	1.3±0.1
G	1.2
H	8.1±0.2
I	6.1±0.2
J	1.0±0.2
K	0.17±0.03
L	0.5
M	0.13
N	0.10
P	3° ^{+5°} _{-3°}
T	0.25
U	0.6±0.15

S30MC-65-5A4-2

<R> • μ PD78F0500MC(A)-CAB-AX, 78F0501MC(A)-CAB-AX, 78F0502MC(A)-CAB-AX, 78F0503MC(A)-CAB-AX

30-PIN PLASTIC SSOP (7.62mm (300))

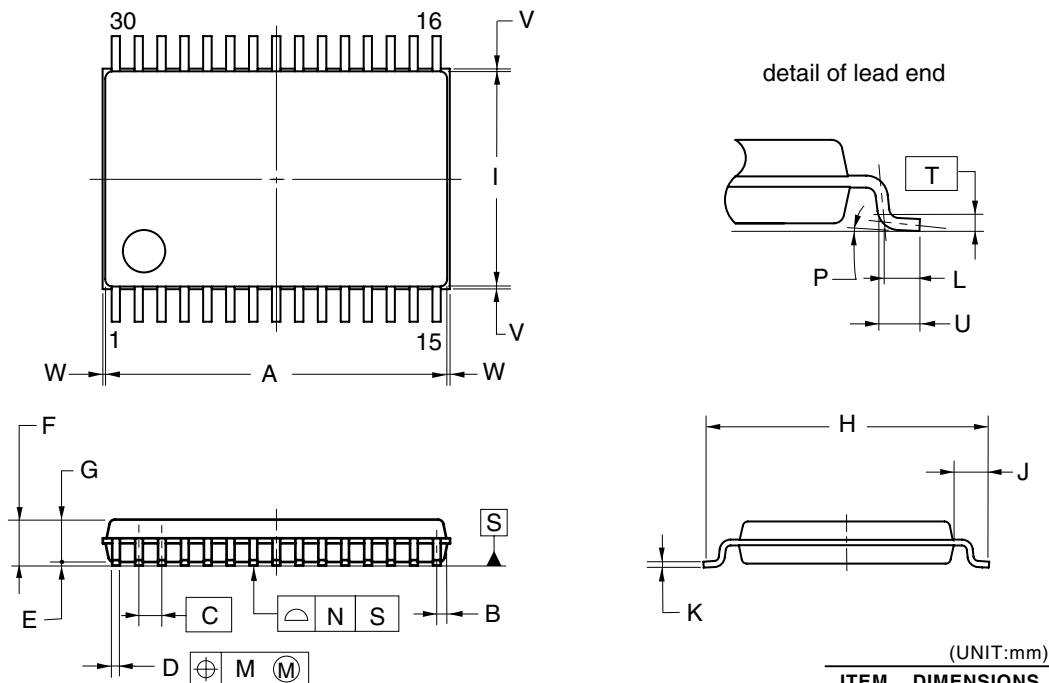

NOTE

Each lead centerline is located within 0.13 mm of its true position (T.P.) at maximum material condition.

(UNIT:mm)

ITEM	DIMENSIONS
A	9.70±0.10
B	0.30
C	0.65 (T.P.)
D	0.22 ^{+0.10} _{-0.05}
E	0.10±0.05
F	1.30±0.10
G	1.20
H	8.10±0.20
I	6.10±0.10
J	1.00±0.20
K	0.15 ^{+0.05} _{-0.01}
L	0.50
M	0.13
N	0.10
P	3° ^{+5°} _{-3°}
T	0.25(T.P.)
U	0.60±0.15
V	0.25 MAX.
W	0.15 MAX.

P30MC-65-CAB

© NEC Electronics Corporation 2005

- μ PD78F0500FC-AA3-A, 78F0501FC-AA3-A, 78F0501FC-AA3-A, 78F0501FC-AA3-A, 78F0503DFC-AA3-A

36-PIN PLASTIC FLGA (4X4)

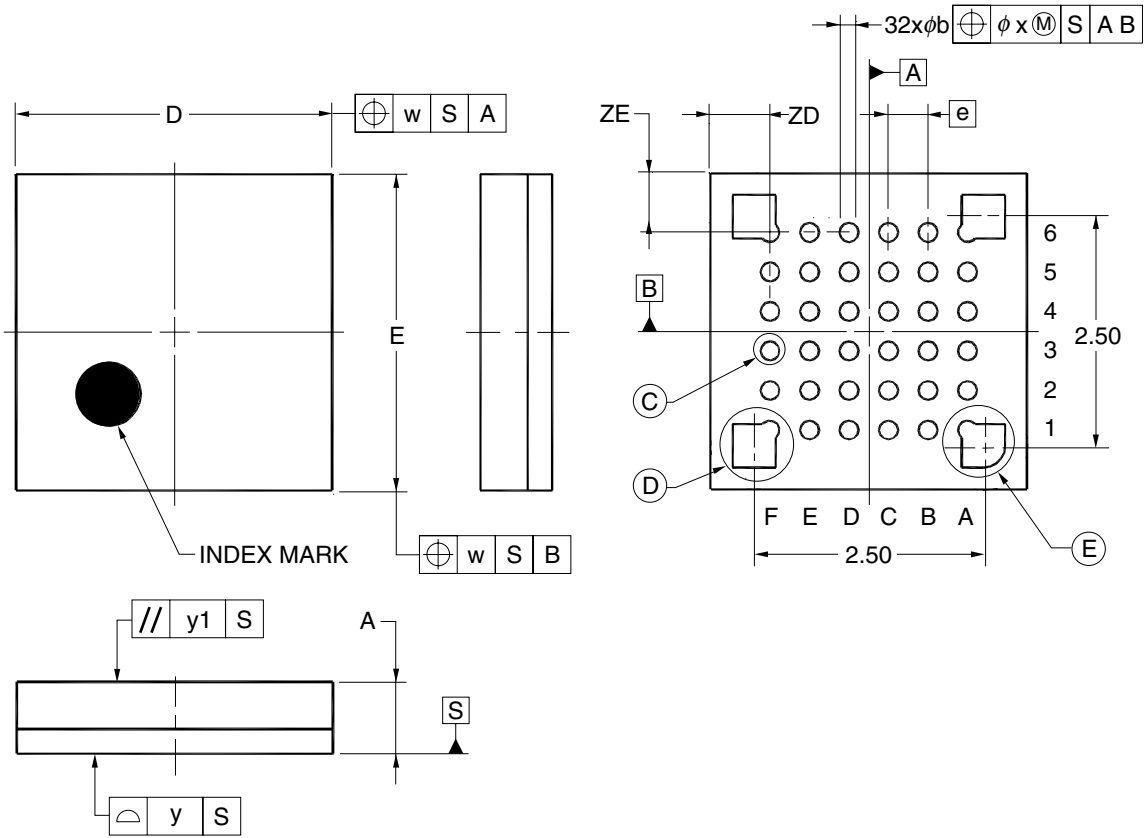

DETAIL OF © PART

DETAIL OF © PART

DETAIL OF © PART

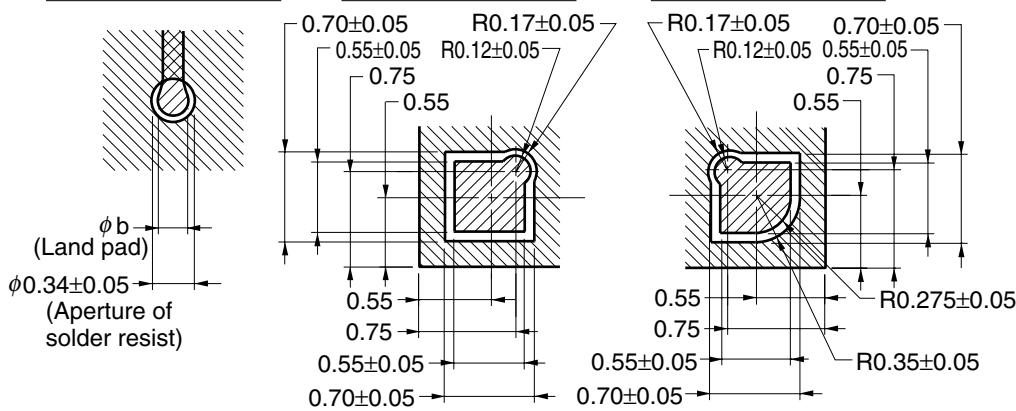

(UNIT:mm)

ITEM	DIMENSIONS
D	4.00±0.10
E	4.00±0.10
w	0.20
e	0.50
A	0.91±0.07
b	0.24±0.05
x	0.05
y	0.08
y1	0.20
ZD	0.75
ZE	0.75

P36FC-50-AA3-1

CHAPTER 27 RECOMMENDED SOLDERING CONDITIONS

These products should be soldered and mounted under the following recommended conditions.

For soldering methods and conditions other than those recommended below, please contact an NEC Electronics sales representative.

For technical information, see the following website.

Semiconductor Device Mount Manual (<http://www.necel.com/pkg/en/mount/index.html>)

Remark Evaluation of the soldering conditions for the (A) standard products is incomplete because these products are under development.

Table 27-1. Surface Mounting Type Soldering Conditions

• **30-pin plastic SSOP (7.62 mm (300))**

μ PD78F0500MC-5A4-A, 78F0501MC-5A4-A, 78F0502MC-5A4-A, 78F0503MC-5A4-A, 78F0503DMC-5A4-A^{Note 1}

• **36-pin plastic FLGA (4 × 4)**

μ PD78F0500FC-AA3-A, 78F0501FC-AA3-A, 78F0502FC-AA3-A, 78F0503FC-AA3-A, 78F0503DFC-AA3-A^{Note 1}

Soldering Method	Soldering Conditions	Recommended Condition Symbol
Infrared reflow	Package peak temperature: 260°C, Time: 60 seconds max. (at 220°C or higher), Count: 3 times or less, Exposure limit: 7 days ^{Note 2} (after that, prebake at 125°C for 20 to 72 hours)	IR60-207-3
Partial heating	Pin temperature: 350°C max., Time: 3 seconds max. (per pin row)	–

Notes 1. The μ PD78F0503D has an on-chip debug function. Do not use this product for mass production because its reliability cannot be guaranteed after the on-chip debug function has been used, due to issues with respect to the number of times the flash memory can be rewritten. NEC Electronics does not accept complaints concerning this product.

2. After opening the dry pack, store it at 25°C or less and 65% RH or less for the allowable storage period.

Caution Do not use different soldering methods together (except for partial heating).

Remark Products with –A at the end of the part number are lead-free products.

CHAPTER 28 CAUTIONS FOR WAIT

28.1 Cautions for Wait

This product has two internal system buses.

One is a CPU bus and the other is a peripheral bus that interfaces with the low-speed peripheral hardware.

Because the clock of the CPU bus and the clock of the peripheral bus are asynchronous, unexpected illegal data may be passed if an access to the CPU conflicts with an access to the peripheral hardware.

When accessing the peripheral hardware that may cause a conflict, therefore, the CPU repeatedly executes processing, until the correct data is passed.

As a result, the CPU does not start the next instruction processing but waits. If this happens, the number of execution clocks of an instruction increases by the number of wait clocks (for the number of wait clocks, see **Tables 28-1**). This must be noted when real-time processing is performed.

28.2 Peripheral Hardware That Generates Wait

Table 28-1 lists the registers that issue a wait request when accessed by the CPU.

Table 28-1. Registers That Generate Wait and Number of CPU Wait Clocks

Peripheral Hardware	Register	Access	Number of Wait Clocks
Serial interface UART0	ASIS0	Read	1 clock (fixed)
Serial interface UART6	ASIS6	Read	1 clock (fixed)
Serial interface IIC0	IICS0	Read	1 clock (fixed)
A/D converter	ADM	Write	1 to 5 clocks (when $f_{AD} = f_{PRS}/2$ is selected)
	ADS	Write	1 to 7 clocks (when $f_{AD} = f_{PRS}/3$ is selected)
	ADPC	Write	1 to 9 clocks (when $f_{AD} = f_{PRS}/4$ is selected)
	ADCR	Read	2 to 13 clocks (when $f_{AD} = f_{PRS}/6$ is selected) 2 to 17 clocks (when $f_{AD} = f_{PRS}/8$ is selected) 2 to 25 clocks (when $f_{AD} = f_{PRS}/12$ is selected)
<p>The above number of clocks is when the same source clock is selected for f_{CPU} and f_{PRS}. The number of wait clocks can be calculated by the following expression and under the following conditions.</p> <p><Calculating number of wait clocks></p> <ul style="list-style-type: none"> • Number of wait clocks = $\frac{2 f_{CPU}}{f_{AD}} + 1$ <p>* Fraction is truncated if the number of wait clocks ≤ 0.5 and rounded up if the number of wait clocks > 0.5.</p> <p>f_{AD}: A/D conversion clock frequency ($f_{PRS}/2$ to $f_{PRS}/12$) f_{CPU}: CPU clock frequency f_{PRS}: Peripheral hardware clock frequency f_{XP}: Main system clock frequency</p> <p><Conditions for maximum/minimum number of wait clocks></p> <ul style="list-style-type: none"> • Maximum number of times: Maximum speed of CPU (f_{XP}), lowest speed of A/D conversion clock ($f_{PRS}/12$) • Minimum number of times: Minimum speed of CPU ($f_{XP}/16$), highest speed of A/D conversion clock ($f_{PRS}/2$) 			

Remark The clock is the CPU clock (f_{CPU}).

APPENDIX A DEVELOPMENT TOOLS

The following development tools are available for the development of systems that employ the 78K0/KB2. Figure A-1 shows the development tool configuration.

- **Support for PC98-NX series**

Unless otherwise specified, products supported by IBM PC/AT™ compatibles are compatible with PC98-NX series computers. When using PC98-NX series computers, refer to the explanation for IBM PC/AT compatibles.

- **Windows™**

Unless otherwise specified, "Windows" means the following OSs.

- Windows 98
- Windows NT™
- Windows 2000
- Windows XP

Figure A-1. Development Tool Configuration (1/2)

(1) When using the in-circuit emulator QB-78K0KX2

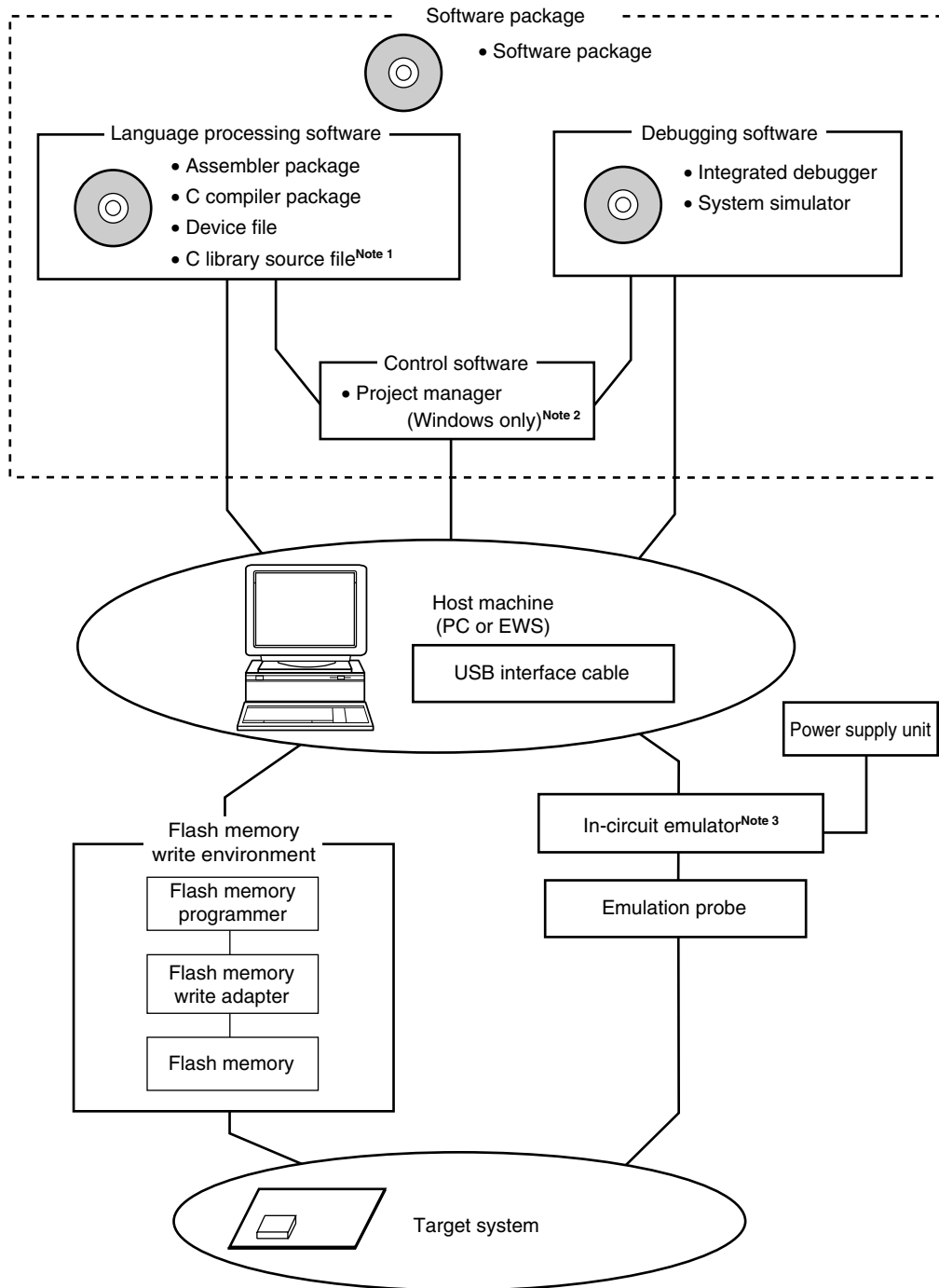

- Notes**
1. The C library source file is not included in the software package.
 2. The project manager PM+ is included in the assembler package. The PM+ is only used for Windows.
 3. In-circuit emulator QB-78K0KX2 is supplied with integrated debugger ID78K0-QB, simple flash memory programmer PG-FPL3, power supply unit, and USB interface cable. Any other products are sold separately.

Figure A-1. Development Tool Configuration (2/2)

(2) When using the on-chip debug emulator QB-78K0MINI

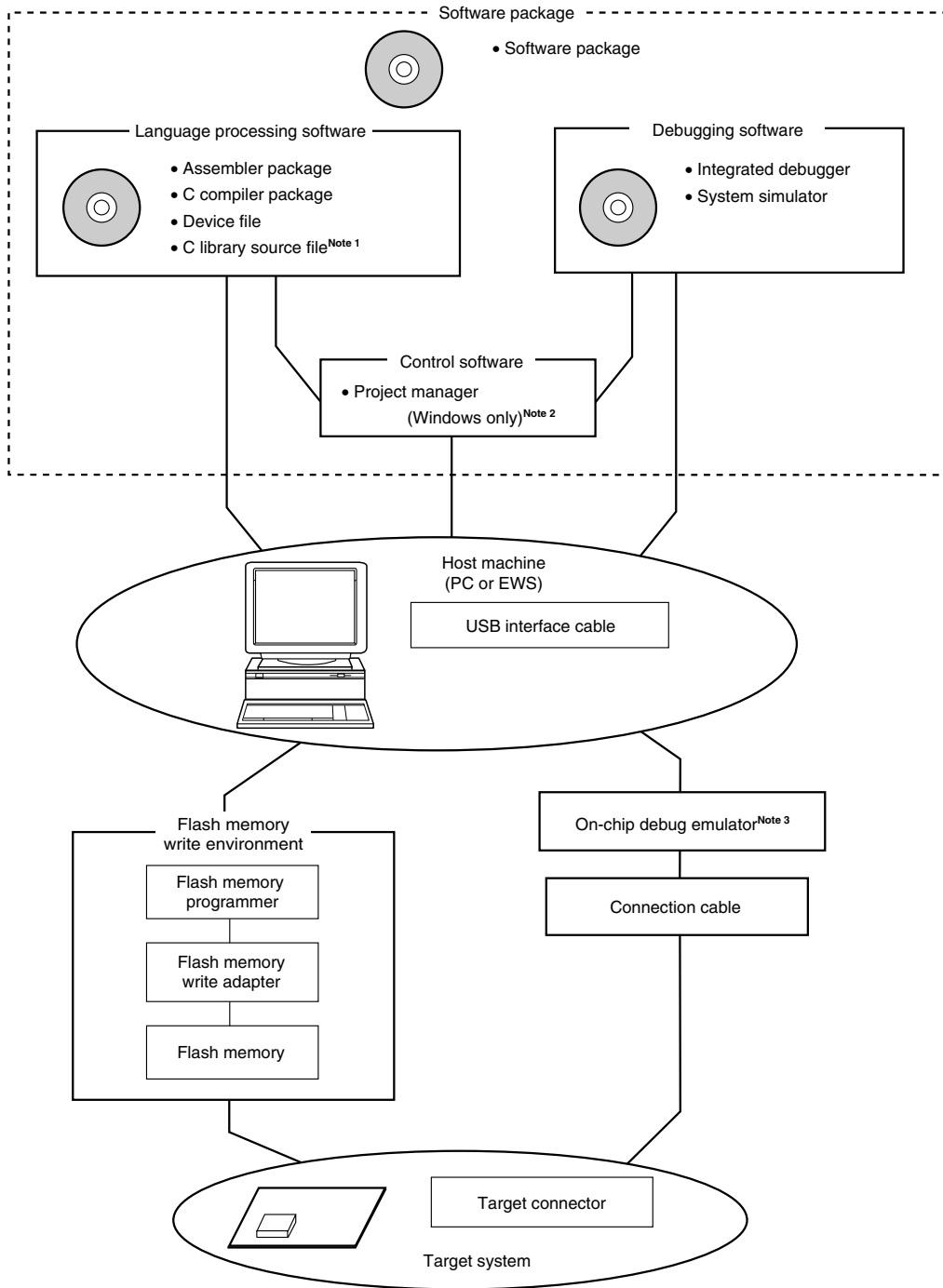

- Notes**
1. The C library source file is not included in the software package.
 2. The project manager PM+ is included in the assembler package. The PM+ is only used for Windows.
 3. The on-chip debug emulator QB-78K0MINI is supplied with integrated debugger ID78K0-QB, USB interface cable, and connection cable. Any other products are sold separately.

A.1 Software Package

SP78K0 78K/0 Series software package	Development tools (software) common to the 78K/0 Series are combined in this package.
	Part number: μ SxxxxSP78K0

Remark xxxx in the part number differs depending on the host machine and OS used.

μ SxxxxSP78K0

xxxx	Host Machine	OS	Supply Medium
AB17	PC-9800 series,	Windows (Japanese version)	CD-ROM
BB17	IBM PC/AT compatibles	Windows (English version)	

A.2 Language Processing Software

RA78K0 Assembler package	<p>This assembler converts programs written in mnemonics into object codes executable with a microcontroller.</p> <p>This assembler is also provided with functions capable of automatically creating symbol tables and branch instruction optimization.</p> <p>This assembler should be used in combination with a device file (DF780547) (sold separately).</p> <p><Precaution when using RA78K0 in PC environment> This assembler package is a DOS-based application. It can also be used in Windows, however, by using the Project Manager (included in assembler package) on Windows.</p> <p>Part number: μSxxxxRA78K0</p>
CC78K0 C compiler package	<p>This compiler converts programs written in C language into object codes executable with a microcontroller.</p> <p>This compiler should be used in combination with an assembler package and device file (both sold separately).</p> <p><Precaution when using CC78K0 in PC environment> This C compiler package is a DOS-based application. It can also be used in Windows, however, by using the Project Manager (included in assembler package) on Windows.</p> <p>Part number: μSxxxxCC78K0</p>
DF780547 ^{Note 1} Device file	<p>This file contains information peculiar to the device.</p> <p>This device file should be used in combination with a tool (RA78K0, CC78K0, SM+ for 78K0/KX2, and ID78K0-QB) (all sold separately).</p> <p>The corresponding OS and host machine differ depending on the tool to be used.</p> <p>Part number: μSxxxxDF780547</p>
CC78K0-L ^{Note 2} C library source file	<p>This is a source file of the functions that configure the object library included in the C compiler package.</p> <p>This file is required to match the object library included in the C compiler package to the user's specifications.</p> <p>Part number: μSxxxxCC78K0-L</p>

- Notes**
1. The DF780547 can be used in common with the RA78K0, CC78K0, SM+ for 78K0/KX2, and ID78K0-QB.
 2. The CC78K0-L is not included in the software package (SP78K0).

Remark xxxx in the part number differs depending on the host machine and OS used.

μSxxxxRA78K0
 μSxxxxCC78K0
 μSxxxxCC78K0-L

xxxx	Host Machine	OS	Supply Medium
AB17	PC-9800 series, IBM PC/AT compatibles	Windows (Japanese version)	CD-ROM
BB17		Windows (English version)	
3P17	HP9000 series 700™	HP-UX™ (Rel. 10.10)	
3K17	SPARCstation™	SunOS™ (Rel. 4.1.4) Solaris™ (Rel. 2.5.1)	

μSxxxxDF780547

xxxx	Host Machine	OS	Supply Medium
AB13	PC-9800 series, IBM PC/AT compatibles	Windows (Japanese version)	3.5-inch 2HD FD
BB13		Windows (English version)	

A.3 Control Software

PM+ Project manager	This is control software designed to enable efficient user program development in the Windows environment. All operations used in development of a user program, such as starting the editor, building, and starting the debugger, can be performed from the project manager. <Caution> The project manager is included in the assembler package (RA78K0). It can only be used in Windows.
------------------------	---

A.4 Flash Memory Writing Tools

PG-FP4, FL-PR4 Flash memory programmer	Flash memory programmer dedicated to microcontrollers with on-chip flash memory.
<R> PG-FPL3, FP-LITE3 Simple flash memory programmer	Simple flash memory programmer dedicated to microcontrollers with on-chip flash memory.
<R> FA-30MC-5A4-A <R> FA-78F0503MC-5A4-MX FA-78F0503FC-AA3-MX Flash memory writing adapter	Flash memory writing adapter used connected to the FlashPro4. <ul style="list-style-type: none"> FA-30MC-5A4-A, FA-78F0503MC-5A4-MX: For 30-pin plastic SSOP (MC-5A4, MC-CAB type) FA-78F0503FC-AA3-MX: For 36-pin plastic FLGA (FC-AA3 type)

Remarks 1. FL-PR4, FP-LITE3, FA-30GC-5A4-A, FA-78F0503MC-5A4-MX, and FA-78F0503FC-AA3-MX, are products of Naito Densai Machida Mfg. Co., Ltd.

TEL: +81-45-475-4191 Naito Densai Machida Mfg. Co., Ltd.

<R> **2.** Use the latest version of the flash memory programming adapter.

A.5 Debugging Tools (Hardware)

A.5.1 When using in-circuit emulator QB-78K0KX2

QB-78K0KX2 ^{Note 1} In-circuit emulator	This in-circuit emulator serves to debug hardware and software when developing application systems using the 78K0/Kx2. It supports to the integrated debugger (ID78K0-QB). This emulator should be used in combination with a power supply unit and emulation probe, and the USB is used to connect this emulator to the host machine.
QB-144-CA-01 Check pin adapter	This check pin adapter is used in waveform monitoring using the oscilloscope, etc.
QB-80-EP-01T Emulation probe	This emulation probe is flexible type and used to connect the in-circuit emulator and target system.
QB-30MC-EA-02T QB-36FC-EA-01T ^{Note 2} Exchange adapter	This exchange adapter is used to perform pin conversion from the in-circuit emulator to target connector. <ul style="list-style-type: none"> • QB-30GC-EA-02T: 30-pin plastic SSOP (MC-5A4, MC-CAB type) • QB-36FC-EA-01T: 36-pin plastic FLGA (FC-AA3 type)
QB-30MC-YS-01T Space adapter	This space adapter is used to adjust the height between the target system and in-circuit emulator. <ul style="list-style-type: none"> • QB-30MC-YS-01T: 30-pin plastic SSOP (MC-5A4, MC-CAB type)
QB-30MC-YQ-01T YQ connector	This YQ connector is used to connect the target connector and exchange adapter. <ul style="list-style-type: none"> • QB-30MC-YQ-01T: 30-pin plastic SSOP (MC-5A4, MC-CAB type)
QB-30MC-HQ-01T Mount adapter	This mount adapter is used to mount the target device with socket. <ul style="list-style-type: none"> • QB-30MC-HQ-01T: 30-pin plastic SSOP (MC-5A4, MC-CAB type)
QB-30MC-NQ-01T, QB-36FC-NQ-01T ^{Note 2} Target connector	This target connector is used to mount on the target system. <ul style="list-style-type: none"> • QB-30MC-NQ-01T: 30-pin plastic SSOP (MC-5A4, MC-CAB type) • QB-36FC-NQ-01T: 36-pin plastic FLGA (FC-AA3 type)

- Notes**
1. The QB-78K0KX2 is supplied with a power supply unit and USB interface cable. As control software, the integrated debugger ID78K0-QB and simple flash memory programmer PG-FPL3 are supplied.
 2. Under development

Remark The packed contents differ depending on the part number, as follows.

Packed Contents Part Number	In-Circuit Emulator	Emulation Probe	Exchange Adapter	YQ Connector	Target Connector
QB-78K0KX2-ZZZ	QB-78K0KX2	None			
QB-78K0KX2-T30MC		QB-80-EP-01T	QB-30MC-EA-02T	QB-30MC-YQ-01T	QB-30MC-NQ-01T
QB-78K0KX2-T36FC ^{Note}			QB-36FC-EA-01T <small>Note</small>	None	QB-36FC-NQ-01T <small>Note</small>

Note Under development

A.5.2 When using on-chip debug emulator QB-78K0MINI

QB-78K0MINI ^{Note} On-chip debug emulator	This on-chip debug emulator serves to debug hardware and software when developing application systems using the 78K0/Kx2. It supports the integrated debugger (ID78K0-QB). This emulator should be used in combination with a connection cable and a USB interface cable that is used to connect the host machine.
Target connector specifications	10-pin general-purpose connector (2.54 mm pitch)

Note The QB-78K0MINI is supplied with a USB interface cable and a connection cable. As control software, the integrated debugger ID78K0-QB is supplied.

A.6 Debugging Tools (Software)

SM+ for 78K0/KX2 System simulator	The SM+ for 78K0/KX2 is Windows-based software. It is used to perform debugging at the C source level or assembler level while simulating the operation of the target system on a host machine. Use of the SM+ for 78K0/KX2 allows the execution of application logical testing and performance testing on an independent basis from hardware development, thereby providing higher development efficiency and software quality. The SM+ for 78K0/KX2 should be used in combination with the device file (DF780547) (sold separately).
	Part number: SM780547-B
ID78K0-QB Integrated debugger	This debugger supports the in-circuit emulators for the 78K/0 Series. The ID78K0-QB is Windows-based software. It has improved C-compatible debugging functions and can display the results of tracing with the source program using an integrating window function that associates the source program, disassemble display, and memory display with the trace result. It should be used in combination with the device file (sold separately).
	Part number: μ SxxxxID78K0-QB

Remark xxxx in the part number differs depending on the host machine and OS used.

μ SxxxxSM780547-B

μ SxxxxID78K0-QB

xxxx	Host Machine	OS	Supply Medium
AB17	PC-9800 series,	Windows (Japanese version)	CD-ROM
BB17	IBM PC/AT compatibles	Windows (English version)	

APPENDIX B NOTES ON TARGET SYSTEM DESIGN

This chapter shows areas on the target system where component mounting is prohibited and areas where there are component mounting height restrictions when the QB-78K0KX2 is used.

Figure B-1. For 30-Pin MC Package

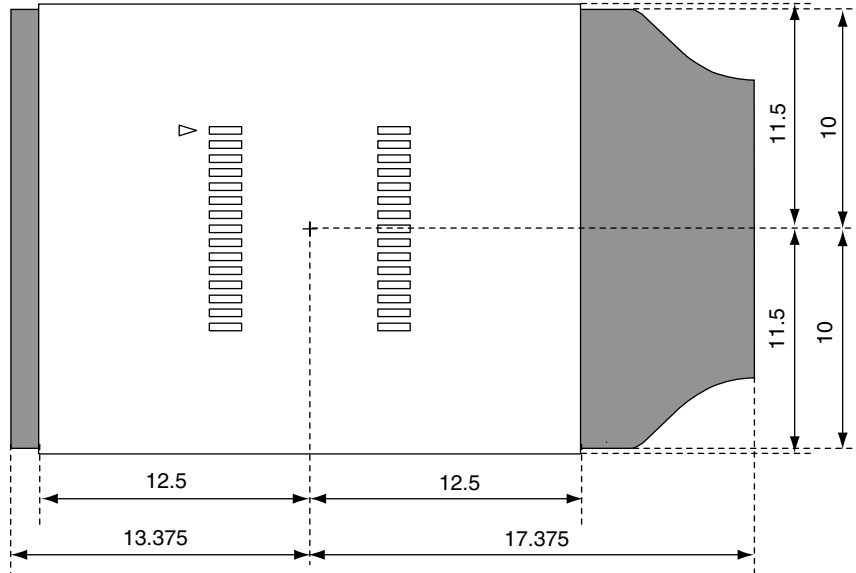

- : Exchange adapter area: Components up to 17.45 mm in height can be mounted^{Note}
■: Emulation probe tip area: Components up to 24.45 mm in height can be mounted^{Note}

Note Height can be adjusted by using space adapters (each adds 2.4 mm)

Figure B-2. For 36-Pin FC Package

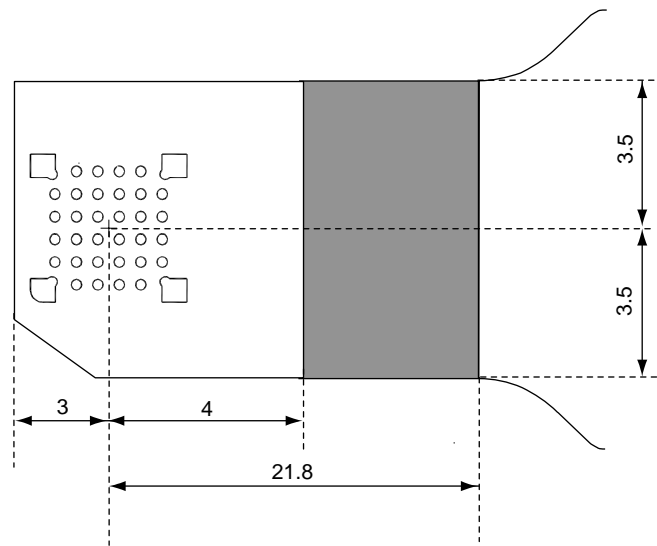

- : Exchange adapter area: Components up to 2.5 mm in height can be mounted
- : Emulation probe tip area: Components up to 4.5 mm in height can be mounted

APPENDIX C REGISTER INDEX

C.1 Register Index (In Alphabetical Order with Respect to Register Names)

1	
10-bit A/D conversion result register (ADCR).....	254
16-bit timer capture/compare register 000 (CR000).....	132
16-bit timer capture/compare register 010 (CR010).....	132
16-bit timer counter 00 (TM00).....	132
16-bit timer mode control register 00 (TMC00)	136
16-bit timer output control register 00 (TOC00).....	139
8	
8-bit A/D conversion result register (ADCRH).....	255
8-bit timer compare register 50 (CR50).....	199
8-bit timer compare register 51 (CR51).....	199
8-bit timer counter 50 (TM50).....	199
8-bit timer counter 51 (TM51).....	199
8-bit timer H carrier control register 1 (TMCYC1).....	222
8-bit timer H compare register 00 (CMP00)	217
8-bit timer H compare register 01 (CMP01)	217
8-bit timer H compare register 10 (CMP10)	217
8-bit timer H compare register 11 (CMP11)	217
8-bit timer H mode register 0 (TMHMD0).....	218
8-bit timer H mode register 1 (TMHMD1).....	218
8-bit timer mode control register 50 (TMC50)	202
8-bit timer mode control register 51 (TMC51)	202
A	
A/D converter mode register (ADM).....	250
A/D port configuration register (ADPC)	95, 257
ADCR: 10-bit A/D conversion result register.....	254
ADCRH: 8-bit A/D conversion result register	255
ADM: A/D converter mode register	250
ADPC: A/D port configuration register	95, 257
ADS: Analog input channel specification register.....	256
Analog input channel specification register (ADS)	256
ASICL6: Asynchronous serial interface control register 6	305
ASIF6: Asynchronous serial interface transmission status register 6.....	302
ASIM0: Asynchronous serial interface operation mode register 0.....	274
ASIM6: Asynchronous serial interface operation mode register 6.....	299
ASIS0: Asynchronous serial interface reception error status register 0	276
ASIS6: Asynchronous serial interface reception error status register 6	301
Asynchronous serial interface control register 6 (ASICL6).....	305
Asynchronous serial interface operation mode register 0 (ASIM0)	274

Asynchronous serial interface operation mode register 6 (ASIM6)	299
Asynchronous serial interface reception error status register 0 (ASIS0)	276
Asynchronous serial interface reception error status register 6 (ASIS6)	301
Asynchronous serial interface transmission status register 6 (ASIF6)	302
B	
Baud rate generator control register 0 (BRGC0)	277
Baud rate generator control register 6 (BRGC6)	304
BRGC0: Baud rate generator control register 0	277
BRGC6: Baud rate generator control register 6	304
C	
Capture/compare control register 00 (CRC00).....	138
CKSR6: Clock selection register 6	303
Clock operation mode select register (OSCCTL)	103
Clock selection register 6 (CKSR6).....	303
CMP00: 8-bit timer H compare register 00	217
CMP01: 8-bit timer H compare register 01	217
CMP10: 8-bit timer H compare register 10	217
CMP11: 8-bit timer H compare register 11	217
CR000: 16-bit timer capture/compare register 000	132
CR010: 16-bit timer capture/compare register 010	132
CR50: 8-bit timer compare register 50	199
CR51: 8-bit timer compare register 51	199
CRC00: Capture/compare control register 00	138
CSIC10: Serial clock selection register 10	333
CSIM10: Serial operation mode register 10	332
E	
EGN: External interrupt falling edge enable register	426
EGP: External interrupt rising edge enable register	426
External interrupt falling edge enable register (EGN).....	426
External interrupt rising edge enable register (EGP).....	426
I	
IF0H: Interrupt request flag register 0H.....	422
IF0L: Interrupt request flag register 0L	422
IF1H: Interrupt request flag register 1H.....	422
IF1L: Interrupt request flag register 1L	422
IIC clock selection register 0 (IICCL0).....	361
IIC control register 0 (IICC0)	352
IIC flag register 0 (IICF0).....	359
IIC function expansion register 0 (IICX0)	362
IIC shift register 0 (IIC0)	349
IIC status register 0 (IICS0).....	357
IIC0: IIC shift register 0	349
IICC0: IIC control register 0.....	352
IICCL0: IIC clock selection register 0	361

IICF0: IIC flag register 0	359
IICS0: IIC status register 0	357
IICX0: IIC function expansion register 0.....	362
IMS: Internal memory size switching register.....	486
Input switch control register (ISC)	307
Internal memory size switching register (IMS)	486
Internal oscillation mode register (RCM).....	106
Interrupt mask flag register 0H (MK0H)	424
Interrupt mask flag register 0L (MK0L).....	424
Interrupt mask flag register 1H (MK1H)	424
Interrupt mask flag register 1L (MK1L).....	424
Interrupt request flag register 0H (IF0H)	422
Interrupt request flag register 0L (IF0L)	422
Interrupt request flag register 1H (IF1H)	422
Interrupt request flag register 1L (IF1L)	422
ISC: Input switch control register	307
L	
Low-voltage detection level selection register (LVIS).....	466
Low-voltage detection register (LVIM)	464
LVIM: Low-voltage detection register.....	464
LVIS: Low-voltage detection level selection register	466
M	
Main clock mode register (MCM)	108
Main OSC control register (MOC).....	107
MCM: Main clock mode register.....	108
MK0H: Interrupt mask flag register 0H.....	424
MK0L: Interrupt mask flag register 0L.....	424
MK1H: Interrupt mask flag register 1H.....	424
MK1L: Interrupt mask flag register 1L.....	424
MOC: Main OSC control register	107
O	
OSCCCTL: Clock operation mode select register	103
Oscillation stabilization time counter status register (OSTC)	109, 436
Oscillation stabilization time select register (OSTS).....	110, 437
OSTC: Oscillation stabilization time counter status register.....	109, 436
OSTS: Oscillation stabilization time select register	110, 437
P	
P0: Port register 0	93
P1: Port register 1	93
P12: Port register 12	93
P2: Port register 2	93
P3: Port register 3	93
P6: Port register 6	93
PCC: Processor clock control register	105

PM0: Port mode register 0	91, 142
PM1: Port mode register 1	91, 204, 223, 278, 307, 334
PM12: Port mode register 12	91, 467
PM2: Port mode register 2	91, 258
PM3: Port mode register 3	91, 204
PM6: Port mode register 6	91, 364
Port mode register 0 (PM0)	91, 142
Port mode register 1 (PM1)	91, 204, 223, 278, 307, 334
Port mode register 12 (PM12)	91, 467
Port mode register 2 (PM2)	91, 258
Port mode register 3 (PM3)	91, 204
Port mode register 6 (PM6)	91, 364
Port register 0 (P0)	93
Port register 1 (P1)	93
Port register 12 (P12)	93
Port register 2 (P2)	93
Port register 3 (P3)	93
Port register 6 (P6)	93
PR0H: Priority specification flag register 0H	425
PR0L: Priority specification flag register 0L	425
PR1H: Priority specification flag register 1H	425
PR1L: Priority specification flag register 1L	425
Prescaler mode register 00 (PRM00)	141
Priority specification flag register 0H (PR0H)	425
Priority specification flag register 0L (PR0L)	425
Priority specification flag register 1H (PR1H)	425
Priority specification flag register 1L (PR1L)	425
PRM00: Prescaler mode register 00	141
Processor clock control register (PCC)	105
PU0: Pull-up resistor option register 0	94
PU1: Pull-up resistor option register 1	94
PU12: Pull-up resistor option register 12	94
PU3: Pull-up resistor option register 3	94
Pull-up resistor option register 0 (PU0)	94
Pull-up resistor option register 1 (PU1)	94
Pull-up resistor option register 12 (PU12)	94
Pull-up resistor option register 3 (PU3)	94
R	
RCM: Internal oscillation mode register	106
Receive buffer register 0 (RXB0)	273
Receive buffer register 6 (RXB6)	298
Receive shift register 0 (RXS0)	273
Receive shift register 6 (RXS6)	298
Reset control flag register (RESF)	456
RESF: Reset control flag register	456

RXB0: Receive buffer register 0.....	273
RXB6: Receive buffer register 6.....	298
RXS0: Receive shift register 0.....	273
RXS6: Receive shift register 6.....	298
S	
Serial clock selection register 10 (CSIC10).....	333
Serial I/O shift register 10 (SIO10).....	331
Serial operation mode register 10 (CSIM10).....	332
SIO10: Serial I/O shift register 10.....	331
Slave address register 0 (SVA0).....	349
SOTB10: Transmit buffer register 10.....	331
SVA0: Slave address register 0.....	349
T	
TCL50: Timer clock selection register 50.....	200
TCL51: Timer clock selection register 51.....	200
Timer clock selection register 50 (TCL50).....	200
Timer clock selection register 51 (TCL51).....	200
TM00: 16-bit timer counter 00.....	132
TM50: 8-bit timer counter 50.....	199
TM51: 8-bit timer counter 51.....	199
TMC00: 16-bit timer mode control register 00.....	136
TMC50: 8-bit timer mode control register 50.....	202
TMC51: 8-bit timer mode control register 51.....	202
TMCYC1: 8-bit timer H carrier control register 1.....	222
TMHMD0: 8-bit timer H mode register 0.....	218
TMHMD1: 8-bit timer H mode register 1.....	218
TOC00: 16-bit timer output control register 00.....	139
Transmit buffer register 10 (SOTB10).....	331
Transmit buffer register 6 (TXB6).....	298
Transmit shift register 0 (TXS0).....	273
Transmit shift register 6 (TXS6).....	298
TXB6: Transmit buffer register 6.....	298
TXS0: Transmit shift register 0.....	273
TXS6: Transmit shift register 6.....	298
W	
Watchdog timer enable register (WDTE).....	242
WDTE: Watchdog timer enable register.....	242

C.2 Register Index (In Alphabetical Order with Respect to Register Symbol)

1	
10-bit A/D conversion result register (ADCR)	254
16-bit timer capture/compare register 000 (CR000)	132
16-bit timer capture/compare register 010 (CR010)	132
16-bit timer counter 00 (TM00)	132
16-bit timer mode control register 00 (TMC00)	136
16-bit timer output control register 00 (TOC00)	139
8	
8-bit A/D conversion result register (ADCRH)	255
8-bit timer compare register 50 (CR50)	199
8-bit timer compare register 51 (CR51)	199
8-bit timer counter 50 (TM50)	199
8-bit timer counter 51 (TM51)	199
8-bit timer H carrier control register 1 (TMCYC1)	222
8-bit timer H compare register 00 (CMP00)	217
8-bit timer H compare register 01 (CMP01)	217
8-bit timer H compare register 10 (CMP10)	217
8-bit timer H compare register 11 (CMP11)	217
8-bit timer H mode register 0 (TMHMD0)	218
8-bit timer H mode register 1 (TMHMD1)	218
8-bit timer mode control register 50 (TMC50)	202
8-bit timer mode control register 51 (TMC51)	202
A	
A/D converter mode register (ADM)	250
A/D port configuration register (ADPC)	95, 257
ADCR: 10-bit A/D conversion result register	254
ADCRH: 8-bit A/D conversion result register	255
ADM: A/D converter mode register	250
ADPC: A/D port configuration register	95, 257
ADS: Analog input channel specification register	256
Analog input channel specification register (ADS)	256
ASICL6: Asynchronous serial interface control register 6	305
ASIF6: Asynchronous serial interface transmission status register 6	302
ASIM0: Asynchronous serial interface operation mode register 0	274
ASIM6: Asynchronous serial interface operation mode register 6	299
ASIS0: Asynchronous serial interface reception error status register 0	276
ASIS6: Asynchronous serial interface reception error status register 6	301
Asynchronous serial interface control register 6 (ASICL6)	305
Asynchronous serial interface operation mode register 0 (ASIM0)	274
Asynchronous serial interface operation mode register 6 (ASIM6)	299
Asynchronous serial interface reception error status register 0 (ASIS0)	276
Asynchronous serial interface reception error status register 6 (ASIS6)	301

Asynchronous serial interface transmission status register 6 (ASIF6)	302
B	
Baud rate generator control register 0 (BRGC0)	277
Baud rate generator control register 6 (BRGC6)	304
BRGC0: Baud rate generator control register 0	277
BRGC6: Baud rate generator control register 6	304
C	
Capture/compare control register 00 (CRC00)	138
CKSR6: Clock selection register 6	303
Clock operation mode select register (OSCCTL)	103
Clock selection register 6 (CKSR6)	303
CMP00: 8-bit timer H compare register 00	217
CMP01: 8-bit timer H compare register 01	217
CMP10: 8-bit timer H compare register 10	217
CMP11: 8-bit timer H compare register 11	217
CR000: 16-bit timer capture/compare register 000	132
CR010: 16-bit timer capture/compare register 010	132
CR50: 8-bit timer compare register 50	199
CR51: 8-bit timer compare register 51	199
CRC00: Capture/compare control register 00	138
CSIC10: Serial clock selection register 10	333
CSIM10: Serial operation mode register 10	332
E	
EGN: External interrupt falling edge enable register	426
EGP: External interrupt rising edge enable register	426
External interrupt falling edge enable register (EGN)	426
External interrupt rising edge enable register (EGP)	426
I	
IF0H: Interrupt request flag register 0H	422
IF0L: Interrupt request flag register 0L	422
IF1H: Interrupt request flag register 1H	422
IF1L: Interrupt request flag register 1L	422
IIC clock selection register 0 (IICCL0)	361
IIC control register 0 (IICC0)	352
IIC flag register 0 (IICF0)	359
IIC function expansion register 0 (IICX0)	362
IIC shift register 0 (IIC0)	349
IIC status register 0 (IICS0)	357
IIC0: IIC shift register 0	349
IICC0: IIC control register 0	352
IICCL0: IIC clock selection register 0	361
IICF0: IIC flag register 0	359
IICS0: IIC status register 0	357
IICX0: IIC function expansion register 0	362

IMS: Internal memory size switching register	486
Input switch control register (ISC)	307
Internal memory size switching register (IMS)	486
Internal oscillation mode register (RCM)	106
Interrupt mask flag register 0H (MK0H)	424
Interrupt mask flag register 0L (MK0L)	424
Interrupt mask flag register 1H (MK1H)	424
Interrupt mask flag register 1L (MK1L)	424
Interrupt request flag register 0H (IF0H)	422
Interrupt request flag register 0L (IF0L)	422
Interrupt request flag register 1H (IF1H)	422
Interrupt request flag register 1L (IF1L)	422
ISC: Input switch control register	307
L	
Low-voltage detection level selection register (LVIS)	466
Low-voltage detection register (LVIM)	464
LVIM: Low-voltage detection register	464
LVIS: Low-voltage detection level selection register	466
M	
Main clock mode register (MCM)	108
Main OSC control register (MOC)	107
MCM: Main clock mode register	108
MK0H: Interrupt mask flag register 0H	424
MK0L: Interrupt mask flag register 0L	424
MK1H: Interrupt mask flag register 1H	424
MK1L: Interrupt mask flag register 1L	424
MOC: Main OSC control register	107
O	
OSCCTL: Clock operation mode select register	103
Oscillation stabilization time counter status register (OSTC)	109, 436
Oscillation stabilization time select register (OSTS)	110, 437
OSTC: Oscillation stabilization time counter status register	109, 436
OSTS: Oscillation stabilization time select register	110, 437
P	
P0: Port register 0	93
P1: Port register 1	93
P12: Port register 12	93
P2: Port register 2	93
P3: Port register 3	93
P6: Port register 6	93
PCC: Processor clock control register	105
PM0: Port mode register 0	91, 142
PM1: Port mode register 1	91, 204, 223, 278, 307, 334
PM12: Port mode register 12	91, 467

PM2: Port mode register 2	91, 258
PM3: Port mode register 3	91, 204
PM6: Port mode register 6	91, 364
Port mode register 0 (PM0)	91, 142
Port mode register 1 (PM1)	91, 204, 223, 278, 307, 334
Port mode register 12 (PM12)	91, 467
Port mode register 2 (PM2)	91, 258
Port mode register 3 (PM3)	91, 204
Port mode register 6 (PM6)	91, 364
Port register 0 (P0)	93
Port register 1 (P1)	93
Port register 12 (P12)	93
Port register 2 (P2)	93
Port register 3 (P3)	93
Port register 6 (P6)	93
PR0H: Priority specification flag register 0H	425
PR0L: Priority specification flag register 0L	425
PR1H: Priority specification flag register 1H	425
PR1L: Priority specification flag register 1L	425
Prescaler mode register 00 (PRM00)	141
Priority specification flag register 0H (PR0H)	425
Priority specification flag register 0L (PR0L)	425
Priority specification flag register 1H (PR1H)	425
Priority specification flag register 1L (PR1L)	425
PRM00: Prescaler mode register 00	141
Processor clock control register (PCC)	105
PU0: Pull-up resistor option register 0	94
PU1: Pull-up resistor option register 1	94
PU12: Pull-up resistor option register 12	94
PU3: Pull-up resistor option register 3	94
Pull-up resistor option register 0 (PU0)	94
Pull-up resistor option register 1 (PU1)	94
Pull-up resistor option register 12 (PU12)	94
Pull-up resistor option register 3 (PU3)	94
R	
RCM: Internal oscillation mode register	106
Receive buffer register 0 (RXB0)	273
Receive buffer register 6 (RXB6)	298
Receive shift register 0 (RXS0)	273
Receive shift register 6 (RXS6)	298
Reset control flag register (RESF)	456
RESF: Reset control flag register	456
RXB0: Receive buffer register 0	273
RXB6: Receive buffer register 6	298
RXS0: Receive shift register 0	273

RXS6: Receive shift register 6	298
S	
Serial clock selection register 10 (CSIC10)	333
Serial I/O shift register 10 (SIO10)	331
Serial operation mode register 10 (CSIM10)	332
SIO10: Serial I/O shift register 10	331
Slave address register 0 (SVA0)	349
SOTB10: Transmit buffer register 10	331
SVA0: Slave address register 0	349
T	
TCL50: Timer clock selection register 50	200
TCL51: Timer clock selection register 51	200
Timer clock selection register 50 (TCL50)	200
Timer clock selection register 51 (TCL51)	200
TM00: 16-bit timer counter 00	132
TM50: 8-bit timer counter 50	199
TM51: 8-bit timer counter 51	199
TMC00: 16-bit timer mode control register 00	136
TMC50: 8-bit timer mode control register 50	202
TMC51: 8-bit timer mode control register 51	202
TMCYC1: 8-bit timer H carrier control register 1	222
TMHMD0: 8-bit timer H mode register 0	218
TMHMD1: 8-bit timer H mode register 1	218
TOC00: 16-bit timer output control register 00	139
Transmit buffer register 10 (SOTB10)	331
Transmit buffer register 6 (TXB6)	298
Transmit shift register 0 (TXS0)	273
Transmit shift register 6 (TXS6)	298
TXB6: Transmit buffer register 6	298
TXS0: Transmit shift register 0	273
TXS6: Transmit shift register 6	298
W	
Watchdog timer enable register (WDTE)	242
WDTE: Watchdog timer enable register	242

APPENDIX D LIST OF CAUTIONS

This appendix lists cautions described in this document.
 “Classification (hard/soft)” in table is as follows.

Hard: Cautions for microcontroller internal/external hardware
 Soft: Cautions for software such as register settings or programs

(1/24)

Chapter	Classification	Function	Details of Function	Cautions	Page
Chapter 1	Hard	Pin function	AV _{SS}	Make AV _{SS} the same potential as V _{SS} .	p. 19 <input type="checkbox"/>
			AV _{SS} , EV _{SS}	Make AV _{SS} and EV _{SS} the same potential as V _{SS} .	p. 20 <input type="checkbox"/>
			EV _{DD}	Make EV _{DD} the same potential as V _{DD} .	p. 20 <input type="checkbox"/>
			REGC	Connect the REGC pin to V _{SS} via a capacitor (0.47 to 1 μF: recommended).	p. 20 <input type="checkbox"/>
			ANI0/P20 to ANI3/P23	ANI0/P20 to ANI3/P23 are set in the analog input mode after release of reset.	p. 20 <input type="checkbox"/>
Chapter 2	Hard	Pin function	ANI0/P20 to ANI3/P23	ANI0/P20 to ANI3/P23 are set in the analog input mode after release of reset.	p. 32 <input type="checkbox"/>
			P31/INTP2/OCD1A	In the products with an on-chip debug function (μPD78F0503D), be sure to pull the P31/INTP2/OCD1A pin down before a reset release, to prevent malfunction.	p. 33 <input type="checkbox"/>
				For the products with an on-chip debug function (μPD78F0503D), connect P31/INTP2/OCD1A as follows when writing the flash memory with a flash memory programmer • P31/INTP2/OCD1A: Connect to V _{SS} via a resistor (10 kΩ: recommended). The above connection is not necessary when writing the flash memory by means of self programming.	p. 33 <input type="checkbox"/>
			P121/X1/OCD0A	For the product with an on-chip debug function (μPD78F0503D), connect P121/X1/OCD0A as follows when writing the flash memory with a flash memory programmer. • P121/X1/OCD0A: When using this pin as a port, connect it to V _{SS} via a resistor (10 kΩ: recommended) (in the input mode) or leave it open (in the output mode). The above connection is not necessary when writing the flash memory by means of self programming.	p. 34 <input type="checkbox"/>
			REGC pin	Keep the wiring length as short as possible for the broken-line part in the above figure.	p. 35 <input type="checkbox"/>
Chapter 3	Soft	Memory space	IMS: Internal memory size switching register,	Regardless of the internal memory capacity, the initial values of the internal memory size switching register (IMS) of all products in the 78K0/KB2 are fixed (IMS = CFH). Therefore, set the value corresponding to each product as indicated below.	p. 40 <input type="checkbox"/>
			SFR: Special function register	Do not access addresses to which SFRs are not assigned.	p. 48 <input type="checkbox"/>
			SP: Stack pointer	Since reset signal generation makes the SP contents undefined, be sure to initialize the SP before using the stack.	p. 54 <input type="checkbox"/>
Chapter 4	Soft	Soft function	P10/SCK10/TxD0, P12/SO10	To use P10/SCK10/TxD0 and P12/SO10 as general-purpose ports, set serial operation mode register 10 (CSIM10) and serial clock selection register 10 (CSIC10) to the default status (00H).	p. 78 <input type="checkbox"/>
	Hard		Port 2	Make the AV _{REF} pin the same potential as the V _{DD} pin when port 2 is used as a digital port.	p. 83 <input type="checkbox"/>

Chapter	Classification	Function	Details of Function	Cautions	Page
Chapter 4	Hard	Soft function	P31/INTP2/OCD1A	In the products with an on-chip debug function (μ PD78F0503D), be sure to pull the P31/INTP2/OCD1A pin down before a reset release, to prevent malfunction.	p. 84 <input type="checkbox"/>
				For the products with an on-chip debug function (μ PD78F0503D), connect P31/INTP2/OCD1A as follows when writing the flash memory with a flash memory programmer. <ul style="list-style-type: none"> • P31/INTP2/OCD1A: Connect to V_{SS} via a resistor (10 kΩ: recommended). The above connection is not necessary when writing the flash memory by means of self programming. 	p. 84 <input type="checkbox"/>
	Soft		P121/X1/OCD0A, P122/X2/EXCLK/OCD0B	When using the P121 and P122 pins to connect a resonator for the main system clock (X1, X2), or to input an external clock for the main system clock (EXCLK), the X1 oscillation mode, or external clock input mode must be set by using the clock operation mode select register (OSCCTL) (for details, see 5.3 (1) Clock operation mode select register (OSCCTL). The reset value of OSCCTL is 00H (all of the P121 and P122 pins are I/O port pins). At this time, setting of the PM121 and PM122 and P121 and P122 pins is not necessary.	p. 88 <input type="checkbox"/>
				For the product with an on-chip debug function (μ PD78F0503D), connect P121/X1/OCD0A as follows when writing the flash memory with a flash memory programmer. <ul style="list-style-type: none"> • P121/X1/OCD0A: When using this pin as a port, connect it to V_{SS} via a resistor (10 kΩ: recommended) (in the input mode) or leave it open (in the output mode). The above connection is not necessary when writing the flash memory by means of self programming. 	p. 88 <input type="checkbox"/>
			Port mode registers	Be sure to set bits 2 to 7 of PM0, bits 4 to 7 of PM2, bits 4 to 7 of PM3, bits 2 to 7 of PM6, bits 3 to 7 of PM12 to 1.	p. 92 <input type="checkbox"/>
			ADPC: A/D port configuration register	Set the channel used for A/D conversion to the input mode by using port mode register 2 (PM2).	p. 95 <input type="checkbox"/>
				If data is written to ADPC, a wait cycle is generated. For details, see CHAPTER 28 CAUTIONS FOR WAIT.	p. 95 <input type="checkbox"/>
				Be sure to clear bits 3 to 7 to 0.	p. 95 <input type="checkbox"/>
			1-bit manipulation instruction for port register n (Pn)	When a 1-bit manipulation instruction is executed on a port that provides both input and output functions, the output latch value of an input port that is not subject to manipulation may be written in addition to the targeted bit. Therefore, it is recommended to rewrite the output latch when switching a port from input mode to output mode.	p. 99 <input type="checkbox"/>
			Chapter 5	Soft	Clock generator
Set AMPH before setting the peripheral functions after a reset release. The value of AMPH can be changed only once after a reset release. When the high-speed system clock (X1 oscillation) is selected as the CPU clock, supply of the CPU clock is stopped for 4.06 to 16.12 μ s after AMPH is set to 1. When the high-speed system clock (external clock input) is selected as the CPU clock, supply of the CPU clock is stopped for the duration of 160 external clocks after AMPH is set to 1.	p. 104 <input type="checkbox"/>				

Chapter	Classification	Function	Details of Function	Caution	Page		
Chapter 5	Soft	Clock generator	OSCCTL: Clock operation mode select register	If the STOP instruction is executed when AMPH = 1, supply of the CPU clock is stopped for 4.06 to 16.12 μ s after the STOP mode is released when the internal high-speed oscillation clock is selected as the CPU clock, or for the duration of 160 external clocks when the high-speed system clock (external clock input) is selected as the CPU clock. When the high-speed system clock (X1 oscillation) is selected as the CPU clock, the oscillation stabilization time is counted after the STOP mode is released.	p. 104 <input type="checkbox"/>		
				To change the value of EXCLK and OSCSEL, be sure to confirm that bit 7 (MSTOP) of the main OSC control register (MOC) is 1 (the X1 oscillator stops or the external clock from the EXCLK pin is disabled).	p. 104 <input type="checkbox"/>		
				Be sure to clear bits 1 to 5 to 0.	p. 104 <input type="checkbox"/>		
					PCC: Processor clock control register	Be sure to clear bits 3 to 7 to "0".	p. 105 <input type="checkbox"/>
					RCM: Internal oscillation mode register	When setting RSTOP to 1, be sure to confirm that the CPU operates with the high-speed system clock (MCS = 1). In addition, stop peripheral hardware that is operating on the internal high-speed oscillation clock before setting RSTOP to 1.	p. 106 <input type="checkbox"/>
					MOC: Main OSC control register	When setting MSTOP to 1, be sure to confirm that the CPU operates with the internal high-speed oscillation clock (MCS = 0). In addition, stop peripheral hardware that is operating on the high-speed system clock before setting MSTOP to 1.	p. 107 <input type="checkbox"/>
						Do not clear MSTOP to 0 while bit 6 (OSCSEL) of the clock operation mode select register (OSCCTL) is 0 (I/O port mode).	p. 107 <input type="checkbox"/>
						The peripheral hardware cannot operate when the peripheral hardware clock is stopped. To resume the operation of the peripheral hardware after the peripheral hardware clock has been stopped, initialize the peripheral hardware.	p. 107 <input type="checkbox"/>
					MCM: Main clock mode register	XSEL can be changed only once after a reset release.	p. 108 <input type="checkbox"/>
						A clock other than f_{PRS} is supplied to the following peripheral functions regardless of the setting of XSEL and MCM0. <ul style="list-style-type: none"> • Watchdog timer (operates with internal low-speed oscillation clock) • When "f_{RL}", "f_{RL}/2ⁿ", or "f_{RL}/2³ⁿ" is selected as the count clock for 8-bit timer H1 (operates with internal low-speed oscillation clock) • Peripheral hardware selects the external clock as the clock source (Except when the external count clock of TM00 is selected (TI000 pin valid edge)) 	p. 108 <input type="checkbox"/>
				Soft	OSTC: Oscillation stabilization time counter status register	After the above time has elapsed, the bits are set to 1 in order from MOST11 and remain 1.	p. 109 <input type="checkbox"/>
							The oscillation stabilization time counter counts up to the oscillation stabilization time set by OSTC. If the STOP mode is entered and then released while the internal high-speed oscillation clock is being used as the CPU clock, set the oscillation stabilization time as follows. <ul style="list-style-type: none"> • Desired OSTC oscillation stabilization time \leq Oscillation stabilization time set by OSTC Note, therefore, that only the status up to the oscillation stabilization time set by OSTC is set to OSTC after STOP mode is released.
				Hard		The X1 clock oscillation stabilization wait time does not include the time until clock oscillation starts ("a" below).	p. 109 <input type="checkbox"/>

Chapter	Classification	Function	Details of Function	Cautions	Page		
Chapter 5	Soft	Clock generator	OSTS: Oscillation stabilization time select register	To set the STOP mode when the X1 clock is used as the CPU clock, set OSTS before executing the STOP instruction.	p. 110 <input type="checkbox"/>		
				Do not change the value of the OSTS register during the X1 clock oscillation stabilization time.	p. 110 <input type="checkbox"/>		
				The oscillation stabilization time counter counts up to the oscillation stabilization time set by OSTS. If the STOP mode is entered and then released while the internal high-speed oscillation clock is being used as the CPU clock, set the oscillation stabilization time as follows. <ul style="list-style-type: none"> Desired OSTC oscillation stabilization time ≤ Oscillation stabilization time set by OSTS Note, therefore, that only the status up to the oscillation stabilization time set by OSTS is set to OSTC after STOP mode is released.	p. 110 <input type="checkbox"/>		
				The X1 clock oscillation stabilization wait time does not include the time until clock oscillation starts ("a" below).	p. 110 <input type="checkbox"/>		
	Hard	X1/XT1 oscillator	-	When using the X1 oscillator and XT1 oscillator, wire as follows in the area enclosed by the broken lines in the Figures 5-9 to avoid an adverse effect from wiring capacitance. <ul style="list-style-type: none"> Keep the wiring length as short as possible. Do not cross the wiring with the other signal lines. Do not route the wiring near a signal line through which a high fluctuating current flows. Always make the ground point of the oscillator capacitor the same potential as V_{SS}. Do not ground the capacitor to a ground pattern through which a high current flows. Do not fetch signals from the oscillator. 	p. 111 <input type="checkbox"/>		
		Clock generator operation when power supply voltage is turned on	-	If the voltage rises with a slope of less than 0.5 V/ms (MIN.) from power application until the voltage reaches 1.8 V, input a low level to the <u>RESET</u> pin from power application until the voltage reaches 1.8 V, or set the 2.7 V/1.59 V POC mode by using the option byte (POCMODE = 1) (see Figure 5-12). By doing so, the CPU operates with the same timing as <2> and thereafter in Figure 5-12 after reset release by the <u>RESET</u> pin. It is not necessary to wait for the oscillation stabilization time when an external clock input from the EXCLK pin is used.	p. 115 <input type="checkbox"/>		
					-	A voltage oscillation stabilization time of 1.93 to 5.39 ms is required after the power supply voltage reaches 1.59 V (TYP.). If the supply voltage rises from 1.59 V (TYP.) to 2.7 V (TYP.) within 1.93 ms, the power supply oscillation stabilization time of 0 to 5.39 ms is automatically generated before reset processing.	pp. 115, 116 <input type="checkbox"/>
							p. 116 <input type="checkbox"/>
		Controlling high-speed system clock	X1/P121, X2/EXCLK/P122	-	The X1/P121 and X2/EXCLK/P122 pins are in the I/O port mode after a reset release.	p. 117 <input type="checkbox"/>	
					X1 clock	Do not change the value of EXCLK and OSCSEL while the X1 clock is operating. Set the X1 clock after the supply voltage has reached the operable voltage of the clock to be used (see CHAPTER 24 ELECTRICAL SPECIFICATIONS (STANDARD PRODUCTS) and CHAPTER 25 ELECTRICAL SPECIFICATIONS ((A) GRADE PRODUCTS, TARGET)).	p. 118 <input type="checkbox"/> p. 118 <input type="checkbox"/>
			External main system clock	-	Do not change the value of EXCLK and OSCSEL while the external main system clock is operating.	p. 118 <input type="checkbox"/>	
					Set the external main system clock after the supply voltage has reached the operable voltage of the clock to be used (see CHAPTER 24 ELECTRICAL SPECIFICATIONS (STANDARD PRODUCTS) and CHAPTER 25 ELECTRICAL SPECIFICATIONS ((A) GRADE PRODUCTS, TARGET)).	p. 118 <input type="checkbox"/>	

Chapter	Classification	Function	Details of Function	Cautions	Page		
Chapter 5	Soft	Controlling high-speed system clock	Main system clock	If the high-speed system clock is selected as the main system clock, a clock other than the high-speed system clock cannot be set as the peripheral hardware clock.	p. 119 <input type="checkbox"/>		
			High-speed system clock	Be sure to confirm that MCS = 0 when setting MSTOP to 1. In addition, stop peripheral hardware that is operating on the high-speed system clock.	p. 120 <input type="checkbox"/>		
		Controlling internal high-speed oscillation clock	Internal high-speed oscillation clock	Be sure to confirm that MCS = 1 when setting RSTOP to 1. In addition, stop peripheral hardware that is operating on the internal high-speed oscillation clock.	p. 122 <input type="checkbox"/>		
		Controlling internal low-speed oscillation clock	Internal low-speed oscillation clock	If "Internal low-speed oscillator cannot be stopped" is selected by the option byte, oscillation of the internal low-speed oscillation clock cannot be controlled.	p. 122 <input type="checkbox"/>		
		CPU clock	–	Set the clock after the supply voltage has reached the operable voltage of the clock to be set (see CHAPTER 24 ELECTRICAL SPECIFICATIONS (STANDARD PRODUCTS) or CHAPTER 25 ELECTRICAL SPECIFICATIONS ((A) GRADE PRODUCTS, TARGET)). When switching the internal high-speed oscillation clock to the high-speed system clock, bit 2 (XSEL) of MCM must be set to 1 in advance. The value of XSEL can be changed only once after a reset release.	pp. 125, 126 <input type="checkbox"/> p. 128 <input type="checkbox"/>		
Chapter 6	Soft	16-bit timer/event counters 00	–	The valid edge of TI010 and timer output (TO00) cannot be used for the P01 pin at the same time. Select either of the functions.	p. 131 <input type="checkbox"/>		
				If clearing of bits 3 and 2 (TMC003 and TMC002) of 16-bit timer mode control register 00 (TMC00) to 00 and input of the capture trigger conflict, then the captured data is undefined.	p. 132 <input type="checkbox"/>		
				To change the mode from the capture mode to the comparison mode, first clear the TMC003 and TMC002 bits to 00, and then change the setting. A value that has been once captured remains stored in CR000 unless the device is reset. If the mode has been changed to the comparison mode, be sure to set a comparison value.	p. 132 <input type="checkbox"/>		
					TM00: 16-bit timer counter 00	Even if TM00 is read, the value is not captured by CR010. When TM00 is read, input of the count clock is temporarily stopped and it is resumed after the timer has been read. Therefore, no clock miss occurs.	p. 132 <input type="checkbox"/> p. 132 <input type="checkbox"/>
					CR000, CR010: 16-bit timer capture/compare registers 000, 010	CR000 does not perform the capture operation when it is set in the comparison mode, even if a capture trigger is input to it.	p. 133 <input type="checkbox"/>
						CR010 does not perform the capture operation when it is set in the comparison mode, even if a capture trigger is input to it.	p. 133 <input type="checkbox"/>
					TMC00: 16-bit timer mode control register 00	16-bit timer/event counter 00 starts operation at the moment TMC002 and TMC003 are set to values other than 00 (operation stop mode), respectively. Set TMC002 and TMC003 to 00 to stop the operation.	p. 136 <input type="checkbox"/>
					CRC00: Capture/compare control register 00	To ensure that the capture operation is performed properly, the capture trigger requires a pulse two cycles longer than the count clock selected by prescaler mode register 00 (PRM00).	p. 138 <input type="checkbox"/>
		Hard					

Chapter	Chapter Classification	Function	Details of Function	Cautions	Page
Chapter 6	Soft	16-bit timer/event counters 00	TOC00: 16-bit timer output control register 00	Be sure to set TOC00 using the following procedure. <1> Set TOC004 and TOC001 to 1. <2> Set only TOE00 to 1. <3> Set either of LVS00 or LVR00 to 1.	p. 139 <input type="checkbox"/>
			PRM00: Prescaler mode register 00	Do not apply the following setting when setting the PRM001 and PRM000 bits to 11 (to specify the valid edge of the TI000 pin as a count clock). • Clear & start mode entered by the TI000 pin valid edge • Setting the TI000 pin as a capture trigger	p. 141 <input type="checkbox"/>
				If the operation of the 16-bit timer/event counter 00 is enabled when the TI000 or TI010 pin is at high level and when the valid edge of the TI000 or TI010 pin is specified to be the rising edge or both edges, the high level of the TI000 or TI010 pin is detected as a rising edge. Note this when the TI000 or TI010 pin is pulled up. However, the rising edge is not detected when the timer operation has been once stopped and then is enabled again.	p. 141 <input type="checkbox"/>
				The valid edge of TI010 and timer output (TO00) cannot be used for the P01 pin at the same time. Select either of the functions.	p. 141 <input type="checkbox"/>
	Soft		Clear & start mode entered by TI000 pin valid edge input	Do not set the count clock as the valid edge of the TI000 pin (PRM001 and PRM000 = 11). When PRM001 and PRM000 = 11, TM00 is cleared.	p. 153 <input type="checkbox"/>
			PPG output	To change the duty factor (value of CR010) during operation, see 6.5.1 Rewriting CR010 during TM00 operation. Set values to CR000 and CR010 such that the condition $0000H \leq CR010 < CR000 \leq FFFFH$ is satisfied.	p. 175 <input type="checkbox"/> p. 176 <input type="checkbox"/>
	Soft		One-shot pulse output	Do not input the trigger again (setting OSPT00 to 1 or detecting the valid edge of the TI000 pin) while the one-shot pulse is output. To output the one-shot pulse again, generate the trigger after the current one-shot pulse output has completed.	p. 178 <input type="checkbox"/>
				To use only the setting of OSPT00 to 1 as the trigger of one-shot pulse output, do not change the level of the TI000 pin or its alternate function port pin. Otherwise, the pulse will be unexpectedly output.	p. 178 <input type="checkbox"/>
				Do not set the same value to CR000 and CR010.	p. 180 <input type="checkbox"/>
	Hard		LVS00, LVR00	Be sure to set LVS00 and LVR00 following steps <1>, <2>, and <3> above. Step <2> can be performed after <1> and before <3>.	p. 192 <input type="checkbox"/>
			Timer start errors	An error of up to one clock may occur in the time required for a match signal to be generated after timer start. This is because counting TM00 is started asynchronously to the count pulse.	p. 193 <input type="checkbox"/>
	Soft		CR000, CR010: 16-bit timer capture/compare registers 000, 010	Set a value other than 0000H to CR000 and CR010 (TM00 cannot count one pulse when it is used as an external event counter).	p. 193 <input type="checkbox"/>

Chapter	Classification	Function	Details of Function	Caution	Page	
Chapter 6	Soft	16-bit timer/event counters 00	CR000, CR010: 16-bit timer capture/compare registers 000, 010	When the valid edge is input to the TI000/TI010 pin and the reverse phase of the TI000 pin is detected while CR000/CR010 is read, CR010 performs a capture operation but the read value of CR000/CR010 is not guaranteed. At this time, an interrupt signal (INTTM000/INTTM010) is generated when the valid edge of the TI000/TI010 pin is detected (the interrupt signal is not generated when the reverse-phase edge of the TI000 pin is detected). When the count value is captured because the valid edge of the TI000/TI010 pin was detected, read the value of CR000/CR010 after INTTM000/INTTM010 is generated.	p. 194 <input type="checkbox"/>	
				The values of CR000 and CR010 are not guaranteed after 16-bit timer/event counter 00 stops.	p. 194 <input type="checkbox"/>	
			ES000, ES001	Set the valid edge of the TI000 pin while the timer operation is stopped (TMC003 and TMC002 = 00). Set the valid edge by using ES000 and ES001.	p. 194 <input type="checkbox"/>	
			Re-triggering one-shot pulse	Make sure that the trigger is not generated while an active level is being output in the one-shot pulse output mode. Be sure to input the next trigger after the current active level is output.	p. 194 <input type="checkbox"/>	
			OVF00	The OVF00 flag is set to 1 in the following case, as well as when TM00 overflows. Select the clear & start mode entered upon a match between TM00 and CR000. →Set CR000 to FFFFH. →When TM00 matches CR000 and TM00 is cleared from FFFFH to 0000H	p. 195 <input type="checkbox"/>	
				Even if the OVF00 flag is cleared to 0 after TM00 overflows and before the next count clock is counted (before the value of TM00 becomes 0001H), it is set to 1 again and clearing is invalid.	p. 195 <input type="checkbox"/>	
			One-shot pulse output	One-shot pulse output operates correctly in the free-running timer mode or the clear & start mode entered by the TI000 pin valid edge. The one-shot pulse cannot be output in the clear & start mode entered upon a match between TM00 and CR000.	p. 195 <input type="checkbox"/>	
			TI000	When the valid edge of TI000 is specified as the count clock, the capture register for which TI000 is specified as a trigger does not operate correctly.	p. 196 <input type="checkbox"/>	
			TI000, TI010	To accurately capture the count value, the pulse input to the TI000 and TI010 pins as a capture trigger must be wider than two count clocks selected by PRM00 (see Figure 6-7).	p. 196 <input type="checkbox"/>	
			INTTM000, INTTM010	The capture operation is performed at the falling edge of the count clock but the interrupt signals (INTTM000 and INTTM010) are generated at the rising edge of the next count clock (see Figure 6-7).	p. 196 <input type="checkbox"/>	
			Soft	CRC001 = 1	When the count value of the TM00 register is captured to the CR000 register in the phase reverse to the signal input to the TI000 pin, the interrupt signal (INTTM000) is not generated after the count value is captured. If the valid edge is detected on the TI010 pin during this operation, the capture operation is not performed but the INTTM000 signal is generated as an external interrupt signal. Mask the INTTM000 signal when the external interrupt is not used.	p. 196 <input type="checkbox"/>
				Hard	Specifying valid edge after reset	If the operation of the 16-bit timer/event counter 00 is enabled after reset and while the TI000 or TI010 pin is at high level and when the rising edge or both the edges are specified as the valid edge of the TI000 or TI010 pin, then the high level of the TI000 or TI010 pin is detected as the rising edge. Note this when the TI000 or TI010 pin is pulled up. However, the rising edge is not detected when the operation is once stopped and then enabled again.
			Sampling clock for eliminating noise		The sampling clock for eliminating noise differs depending on whether the valid edge of TI000 is used as the count clock or capture trigger. In the former case, the sampling clock is fixed to f _{PRS} . In the latter, the count clock selected by PRM00 is used for sampling. When the signal input to the TI000 pin is sampled and the valid level is detected two times in a row, the valid edge is detected. Therefore, noise having a short pulse width can be eliminated (see Figure 6-7).	p. 196 <input type="checkbox"/>
			TI000/TI010		The signal input to the TI000/TI010 pin is not acknowledged while the timer is stopped, regardless of the operation mode of the CPU.	p. 196 <input type="checkbox"/>

Chapter	Classification	Function	Details of Function	Cautions	Page
Chapter 7	Soft	8-bit timer/event counters 50, 51	CR5n: 8-bit timer compare register 5n	In the mode in which clear & start occurs on a match of TM5n and CR5n (TMC5n6 = 0), do not write other values to CR5n during operation.	p. 199 <input type="checkbox"/>
				In PWM mode, make the CR5n rewrite period 3 count clocks of the count clock (clock selected by TCL5n) or more.	p. 199 <input type="checkbox"/>
			TCL50: Timer clock selection register 50	When rewriting TCL50 to other data, stop the timer operation beforehand.	p. 200 <input type="checkbox"/>
				Be sure to clear bits 3 to 7 to "0".	p. 200 <input type="checkbox"/>
			TCL51: Timer clock selection register 51	When rewriting TCL51 to other data, stop the timer operation beforehand.	p. 201 <input type="checkbox"/>
				Be sure to clear bits 3 to 7 to "0".	p. 201 <input type="checkbox"/>
			TMC5n: 8-bit timer mode control register 51 (TMC51)	The settings of LVS5n and LVR5n are valid in other than PWM mode.	p. 203 <input type="checkbox"/>
				Perform <1> to <4> below in the following order, not at the same time. <1> Set TMC5n1, TMC5n6: Operation mode setting <2> Set TOE5n to enable output: Timer output enable <3> Set LVS5n, LVR5n (see Caution 1): Timer F/F setting <4> Set TCE5n	p. 203 <input type="checkbox"/>
				When TCE5n = 1, setting the other bits of TMC5n is prohibited.	p. 203 <input type="checkbox"/>
			Interval timer	Do not write other values to CR5n during operation.	p. 205 <input type="checkbox"/>
			Square-wave output	Do not write other values to CR5n during operation.	p. 208 <input type="checkbox"/>
			PWM output	In PWM mode, make the CR5n rewrite period 3 count clocks of the count clock (clock selected by TCL5n) or more.	p. 209 <input type="checkbox"/>
				When reading from CR5n between <1> and <2> in Figure 7-15, the value read differs from the actual value (read value: M, actual value of CR5n: N).	p. 212 <input type="checkbox"/>
Timer start error	An error of up to one clock may occur in the time required for a match signal to be generated after timer start. This is because 8-bit timer counters 50 and 51 (TM50, TM51) are started asynchronously to the count clock.	p. 213 <input type="checkbox"/>			
Chapter 8	Soft	8-bit timers H0, H1	CMP0n: 8-bit timer H compare register 0n (CMP0n)	CMP0n cannot be rewritten during timer count operation. CMP0n can be refreshed (the same value is written) during timer count operation.	p. 217 <input type="checkbox"/>
			CMP1n: 8-bit timer H compare register 1n (CMP1n)	In the PWM output mode and carrier generator mode, be sure to set CMP1n when starting the timer count operation (TMHEn = 1) after the timer count operation was stopped (TMHEn = 0) (be sure to set again even if setting the same value to CMP1n).	p. 217 <input type="checkbox"/>
			TMHMD0: 8-bit timer H mode register 0	When TMHE0 = 1, setting the other bits of TMHMD0 is prohibited. However, TMHMD0 can be refreshed (the same value is written).	p. 220 <input type="checkbox"/>
				In the PWM output mode, be sure to set the 8-bit timer H compare register 10 (CMP10) when starting the timer count operation (TMHE0 = 1) after the timer count operation was stopped (TMHE0 = 0) (be sure to set again even if setting the same value to CMP10).	p. 220 <input type="checkbox"/>
			TMHMD1: 8-bit timer H mode register 1	When TMHE1 = 1, setting the other bits of TMHMD1 is prohibited. However, TMHMD1 can be refreshed (the same value is written).	p. 222 <input type="checkbox"/>
				In the PWM output mode and carrier generator mode, be sure to set the 8-bit timer H compare register 11 (CMP11) when starting the timer count operation (TMHE1 = 1) after the timer count operation was stopped (TMHE1 = 0) (be sure to set again even if setting the same value to CMP11).	p. 222 <input type="checkbox"/>
	When the carrier generator mode is used, set so that the count clock frequency of TMH1 becomes more than 6 times the count clock frequency of TM51.	p. 222 <input type="checkbox"/>			
TMCYC1: 8-bit timer H carrier register 1	Do not rewrite RMC1 when TMHE = 1. However, TMCYC1 can be refreshed (the same value is written).	p. 222 <input type="checkbox"/>			

Chapter	Classification	Function	Details of Function	Cautions	Page				
Chapter 8	Hard	8-bit timers H0, H1	PWM output	The set value of the CMP1n register can be changed while the timer counter is operating. However, this takes a duration of three operating clocks (signal selected by the CKSn2 to CKSn0 bits of the TMHMDn register) from when the value of the CMP1n register is changed until the value is transferred to the register.	p. 228 <input type="checkbox"/>				
				Be sure to set the CMP1n register when starting the timer count operation (TMHEN = 1) after the timer count operation was stopped (TMHEN = 0) (be sure to set again even if setting the same value to the CMP1n register).	p. 228 <input type="checkbox"/>				
	Make sure that the CMP1n register setting value (M) and CMP0n register setting value (N) are within the following range. 00H ≤ CMP1n (M) < CMP0n (N) ≤ FFH			p. 228 <input type="checkbox"/>					
	Soft		Carrier generator (8-bit timer H1 only)	Do not rewrite the NRZB1 bit again until at least the second clock after it has been rewritten, or else the transfer from the NRZB1 bit to the NRZ1 bit is not guaranteed.	p. 234 <input type="checkbox"/>				
				When the 8-bit timer/event counter 51 is used in the carrier generator mode, an interrupt is generated at the timing of <1>. When the 8-bit timer/event counter 51 is used in a mode other than the carrier generator mode, the timing of the interrupt generation differs.	p. 234 <input type="checkbox"/>				
				Be sure to set the CMP11 register when starting the timer count operation (TMHE1 = 1) after the timer count operation was stopped (TMHE1 = 0) (be sure to set again even if setting the same value to the CMP11 register).	p. 236 <input type="checkbox"/>				
				Set so that the count clock frequency of TMH1 becomes more than 6 times the count clock frequency of TM51.	p. 236 <input type="checkbox"/>				
				Set the values of the CMP01 and CMP11 registers in a range of 01H to FFH.	p. 236 <input type="checkbox"/>				
				The set value of the CMP11 register can be changed while the timer counter is operating. However, it takes the duration of three operating clocks (signal selected by the CKS12 to CKS10 bits of the TMHMD1 register) since the value of the CMP11 register has been changed until the value is transferred to the register.	p. 236 <input type="checkbox"/>				
				Be sure to set the RMC1 bit before the count operation is started.	p. 236 <input type="checkbox"/>				
				Chapter 9	Soft	Watchdog timer	WDTE: Watchdog timer enable register	If a value other than ACH is written to WDTE, an internal reset signal is generated. If the source clock to the watchdog timer is stopped, however, an internal reset signal is generated when the source clock to the watchdog timer resumes operation.	p. 242 <input type="checkbox"/>
								If a 1-bit memory manipulation instruction is executed for WDTE, an internal reset signal is generated. If the source clock to the watchdog timer is stopped, however, an internal reset signal is generated when the source clock to the watchdog timer resumes operation.	p. 242 <input type="checkbox"/>
								The value read from WDTE is 9AH/1AH (this differs from the written value (ACH)).	p. 242 <input type="checkbox"/>
Operation control	The first writing to WDTE after a reset release clears the watchdog timer, if it is made before the overflow time regardless of the timing of the writing, and the watchdog timer starts counting again.	p. 243 <input type="checkbox"/>							
	If the watchdog timer is cleared by writing "ACH" to WDTE, the actual overflow time may be different from the overflow time set by the option byte by up to 2/frL seconds.	p. 243 <input type="checkbox"/>							
	The watchdog timer can be cleared immediately before the count value overflows (FFFFH).	p. 243 <input type="checkbox"/>							

Chapter	Classification	Function	Details of Function	Cautions	Page
Chapter 9	Soft	Watchdog timer	Operation control	The operation of the watchdog timer in the HALT and STOP modes differs as follows depending on the set value of bit 0 (LSROSC) of the option byte (see Table on p. 271). If LSROSC = 0, the watchdog timer resumes counting after the HALT or STOP mode is released. At this time, the counter is not cleared to 0 but starts counting from the value at which it was stopped. If oscillation of the internal low-speed oscillator is stopped by setting LSRSTOP (bit 1 of the internal oscillation mode register (RCM) = 1) when LSROSC = 0, the watchdog timer stops operating. At this time, the counter is not cleared to 0.	p. 244 <input type="checkbox"/>
			Setting overflow time of watchdog timer,	The combination of WDCS2 = WDCS1 = WDCS0 = 0 and WINDOW1 = WINDOW0 = 0 is prohibited.	pp. 244, 245 <input type="checkbox"/>
			Setting window open period of watchdog time	The watchdog timer continues its operation during self-programming and EEPROM emulation of the flash memory. During processing, the interrupt acknowledge time is delayed. Set the overflow time and window size taking this delay into consideration.	pp. 244, 245 <input type="checkbox"/>
			Setting window open period of watchdog timer	The first writing to WDTE after a reset release clears the watchdog timer, if it is made before the overflow time regardless of the timing of the writing, and the watchdog timer starts counting again.	p. 245 <input type="checkbox"/>
Chapter 10	Soft	A/D converter	ADCR: 10-bit A/D conversion register, ADCRH: 8-bit A/D conversion register	When data is read from ADCR and ADCRH, a wait cycle is generated. For details, see CHAPTER 28 CAUTIONS FOR WAIT.	p. 249 <input type="checkbox"/>
			ADM: A/D converter mode register	A/D conversion must be stopped before rewriting bits FR0 to FR2, LV1, and LV0 to values other than the identical data. If data is written to ADM, a wait cycle is generated. For details, see CHAPTER 28 CAUTIONS FOR WAIT.	p. 251 <input type="checkbox"/>
			A/D conversion timer selection	Set the conversion times with the following conditions. • 4.0 V ≤ AV _{REF} ≤ 5.5 V: f _{AD} = 0.6 to 3.6 MHz • 2.7 V ≤ AV _{REF} < 4.0 V: f _{AD} = 0.6 to 1.8 MHz • 2.3 V ≤ AV _{REF} < 2.7 V: f _{AD} = 0.6 to 1.48 MHz	p. 252 <input type="checkbox"/>
				When rewriting FR2 to FR0, LV1, and LV0 to other than the same data, stop A/D conversion once (ADCS = 0) beforehand.	p. 252 <input type="checkbox"/>
				Change LV1 and LV0 from the default value, when 2.3 V ≤ AV _{REF} < 2.7 V.	p. 252 <input type="checkbox"/>
				The above conversion time does not include clock frequency errors. Select conversion time, taking clock frequency errors into consideration.	p. 252 <input type="checkbox"/>
			ADCR: 10-bit A/D conversion register	When writing to the A/D converter mode register (ADM), analog input channel specification register (ADS), and A/D port configuration register (ADPC), the contents of ADCR may become undefined. Read the conversion result following conversion completion before writing to ADM, ADS, and ADPC. Using timing other than the above may cause an incorrect conversion result to be read.	p. 254 <input type="checkbox"/>
				If data is read from ADCR, a wait cycle is generated. For details, see CHAPTER 28 CAUTIONS FOR WAIT.	p. 254 <input type="checkbox"/>

Chapter	Classification	Function	Details of Function	Cautions	Page	
Chapter 10	Soft	A/D converter	ADCRH: 8-bit A/D conversion register	When writing to the A/D converter mode register (ADM), analog input channel specification register (ADS), and A/D port configuration register (ADPC), the contents of ADCRH may become undefined. Read the conversion result following conversion completion before writing to ADM, ADS, and ADPC. Using timing other than the above may cause an incorrect conversion result to be read.	p. 255	<input type="checkbox"/>
				If data is read from ADCR, a wait cycle is generated. For details, see CHAPTER 28 CAUTIONS FOR WAIT.	p. 255	<input type="checkbox"/>
			ADS: Analog input channel specification register	Be sure to clear bits 2 to 7 to 0.	p. 256	<input type="checkbox"/>
				If data is written to ADS, a wait cycle is generated. For details, see CHAPTER 28 CAUTIONS FOR WAIT.	p. 256	<input type="checkbox"/>
			ADS: Analog input channel specification register, ADPC: A/D port configuration register (ADPC)	Set a channel to be used for A/D conversion in the input mode by using port mode register 2 (PM2).	pp. 256, 257	<input type="checkbox"/>
				ADPC: A/D port configuration register (ADPC)	Be sure to clear bits 3 to 7 to 0.	p. 257
			ADPC: A/D port configuration register (ADPC)		If data is written to ADPC, a wait cycle is generated. For details, see CHAPTER 28 CAUTIONS FOR WAIT.	p. 257
				Basic operations of A/D converter	Make sure the period of <1> to <5> is 1 μ s or more.	p. 259
			A/D conversion operation	Make sure the period of <1> to <5> is 1 μ s or more.	p. 263	<input type="checkbox"/>
				<1> may be done between <2> and <4>.	p. 263	<input type="checkbox"/>
				<1> can be omitted. However, ignore data of the first conversion after <5> in this case.	p. 263	<input type="checkbox"/>
				The period from <6> to <9> differs from the conversion time set using bits 5 to 1 (FR2 to FR0, LV1, LV0) of ADM. The period from <8> to <9> is the conversion time set using FR2 to FR0, LV1, and LV0.	p. 263	<input type="checkbox"/>
	Operating current in STOP mode	The A/D converter stops operating in the STOP mode. At this time, the operating current can be reduced by clearing bit 7 (ADCS) and bit 0 (ADCE) of the A/D converter mode register (ADM) to 0. To restart from the standby status, clear bit 0 (ADIF) of interrupt request flag register 1L (IF1L) to 0 and start operation.	p. 266	<input type="checkbox"/>		
	Hard	Input range of ANI0 to ANI3	Observe the rated range of the ANI0 to ANI3 input voltage. If a voltage of AV_{REF} or higher and AV_{SS} or lower (even in the range of absolute maximum ratings) is input to an analog input channel, the converted value of that channel becomes undefined. In addition, the converted values of the other channels may also be affected.	p. 266	<input type="checkbox"/>	
			Soft	Conflicting operations	If conflict occurs between A/D conversion result register (ADCR, ADCRH) write and ADCR or ADCRH read by instruction upon the end of conversion, ADCR or ADCRH read has priority. After the read operation, the new conversion result is written to ADCR or ADCRH.	p. 266
If conflict occurs between ADCR or ADCRH write and A/D converter mode register (ADM) write, analog input channel specification register (ADS), or A/D port configuration register (ADPC) write upon the end of conversion, ADM, ADS, or ADPC write has priority. ADCR or ADCRH write is not performed, nor is the conversion end interrupt signal (INTAD) generated.	p. 266	<input type="checkbox"/>				

Chapter	Classification	Function	Details of Function	Cautions	Page		
Chapter 10	Hard	A/D converter	Noise countermeasures	To maintain the 10-bit resolution, attention must be paid to noise input to the AV _{REF} pin and pins ANI0 to ANI3. <ul style="list-style-type: none"> • Connect a capacitor with a low equivalent resistance and a good frequency response to the power supply. • The higher the output impedance of the analog input source, the greater the influence. To reduce the noise, connecting external C as shown in Figure 10-20 is recommended. • Do not switch these pins with other pins during conversion. • The accuracy is improved if the HALT mode is set immediately after the start of conversion. 	p. 266	<input type="checkbox"/>	
			ANI0/P20 to ANI3/P23	The analog input pins (ANI0 to ANI3) are also used as input port pins (P20 to P23). When A/D conversion is performed with any of ANI0 to ANI3 selected, do not access P20 to P23 while conversion is in progress; otherwise the conversion resolution may be degraded. It is recommended to select pins used as P20 to P23 starting with the ANI0/P20 that is the furthest from AV _{REF} . If a digital pulse is applied to the pins adjacent to the pins currently used for A/D conversion, the expected value of the A/D conversion may not be obtained due to coupling noise. Therefore, do not apply a pulse to the pins adjacent to the pin undergoing A/D conversion.	p. 267	<input type="checkbox"/>	
			Input impedance of ANI0 to ANI7 pins	This A/D converter charges a sampling capacitor for sampling during sampling time. Therefore, only a leakage current flows when sampling is not in progress, and a current that charges the capacitor flows during sampling. Consequently, the input impedance fluctuates depending on whether sampling is in progress, and on the other states. To make sure that sampling is effective, however, it is recommended to keep the output impedance of the analog input source to within 10 kΩ, and to connect a capacitor of about 100 pF to the ANI0 to ANI3 pins (see Figure 12-20).	p. 267	<input type="checkbox"/>	
			AV _{REF} pin input impedance	A series resistor string of several tens of kΩ is connected between the AV _{REF} and AV _{SS} pins. Therefore, if the output impedance of the reference voltage source is high, this will result in a series connection to the series resistor string between the AV _{REF} and AV _{SS} pins, resulting in a large reference voltage error.	p. 267	<input type="checkbox"/>	
			Interrupt request flag (ADIF)	The interrupt request flag (ADIF) is not cleared even if the analog input channel specification register (ADS) is changed. Therefore, if an analog input pin is changed during A/D conversion, the A/D conversion result and ADIF for the pre-change analog input may be set just before the ADS rewrite. Caution is therefore required since, at this time, when ADIF is read immediately after the ADS rewrite, ADIF is set despite the fact A/D conversion for the post-change analog input has not ended. When A/D conversion is stopped and then resumed, clear ADIF before the A/D conversion operation is resumed.	p. 268	<input type="checkbox"/>	
	Conversion results just after A/D conversion start		The first A/D conversion value immediately after A/D conversion starts may not fall within the rating range if the ADCS bit is set to 1 within 1 μs after the ADCE bit was set to 1, or if the ADCS bit is set to 1 with the ADCE bit = 0. Take measures such as polling the A/D conversion end interrupt request (INTAD) and removing the first conversion result.	p. 268	<input type="checkbox"/>		
	A/D conversion result register (ADCR, ADCRH) read operation		When a write operation is performed to the A/D converter mode register (ADM), analog input channel specification register (ADS), and A/D port configuration register (ADPC), the contents of ADCR and ADCRH may become undefined. Read the conversion result following conversion completion before writing to ADM, ADS, and ADPC. Using a timing other than the above may cause an incorrect conversion result to be read.	p. 268	<input type="checkbox"/>		
	Soft						

Chapter	Chapter Classification	Function	Details of Function	Cautions	Page	
Chapter 11	Soft	Serial interface UART0	UART mode	If clock supply to serial interface UART0 is not stopped (e.g., in the HALT mode), normal operation continues. If clock supply to serial interface UART0 is stopped (e.g., in the STOP mode), each register stops operating, and holds the value immediately before clock supply was stopped. The TxD0 pin also holds the value immediately before clock supply was stopped and outputs it. However, the operation is not guaranteed after clock supply is resumed. Therefore, reset the circuit so that POWER0 = 0, RXE0 = 0, and TXE0 = 0.	p. 270 <input type="checkbox"/>	
				Set POWER0 = 1 and then set TXE0 = 1 (transmission) or RXE0 = 1 (reception) to start communication.	p. 270 <input type="checkbox"/>	
				TXE0 and RXE0 are synchronized by the base clock (f _{CLK0}) set by BRGC0. To enable transmission or reception again, set TXE0 or RXE0 to 1 at least two clocks of base clock after TXE0 or RXE0 has been cleared to 0. If TXE0 or RXE0 is set within two clocks of base clock, the transmission circuit or reception circuit may not be initialized.	p. 270 <input type="checkbox"/>	
				Set transmit data to TXS0 at least one base clock (f _{CLK0}) after setting TXE0 = 1.	pp. 270 <input type="checkbox"/> 273	
			TXS0: Transmit shift register 0	Do not write the next transmit data to TXS0 before the transmission completion interrupt signal (INTST0) is generated.	p. 273 <input type="checkbox"/>	
			ASIM0: Asynchronous serial interface operation mode register 0	To start the transmission, set POWER0 to 1 and then set TXE0 to 1. To stop the transmission, clear TXE0 to 0, and then clear POWER0 to 0.	p. 275 <input type="checkbox"/>	
				To start the reception, set POWER0 to 1 and then set RXE0 to 1. To stop the reception, clear RXE0 to 0, and then clear POWER0 to 0.	p. 275 <input type="checkbox"/>	
				Set POWER0 to 1 and then set RXE0 to 1 while a high level is input to the RxD0 pin. If POWER0 is set to 1 and RXE0 is set to 1 while a low level is input, reception is started.	p. 275 <input type="checkbox"/>	
				TXE0 and RXE0 are synchronized by the base clock (f _{CLK0}) set by BRGC0. To enable transmission or reception again, set TXE0 or RXE0 to 1 at least two clocks of base clock after TXE0 or RXE0 has been cleared to 0. If TXE0 or RXE0 is set within two clocks of base clock, the transmission circuit or reception circuit may not be initialized.	p. 275 <input type="checkbox"/>	
				Set transmit data to TXS0 at least one base clock (f _{CLK0}) after setting TXE0 = 1.	p. 275 <input type="checkbox"/>	
				Clear the TXE0 and RXE0 bits to 0 before rewriting the PS01, PS00, and CL0 bits.	p. 275 <input type="checkbox"/>	
				Make sure that TXE0 = 0 when rewriting the SL0 bit. Reception is always performed with “number of stop bits = 1”, and therefore, is not affected by the set value of the SL0 bit.	p. 275 <input type="checkbox"/>	
				Be sure to set bit 0 to 1.	p. 275 <input type="checkbox"/>	
			ASIS0: Asynchronous serial interface reception error status register 0	The operation of the PE0 bit differs depending on the set values of the PS01 and PS00 bits of asynchronous serial interface operation mode register 0 (ASIM0).	p. 276 <input type="checkbox"/>	
				For the stop bit of the receive data, only the first stop bit is checked regardless of the number of the stops bits.	p. 276 <input type="checkbox"/>	
				If an overrun error occurs, the next receive data is not written to receive buffer register 0 (RXB0) but discarded.	p. 276 <input type="checkbox"/>	
				If data is read from ASIS0, a wait cycle is generated. For details, see CHAPTER 28 CAUTIONS FOR WAIT.	p. 276 <input type="checkbox"/>	
			BRGC0: Baud rate generator control register 0	Make sure that bit 6 (TXE0) and bit 5 (RXE0) of the ASIM0 register = 0 when rewriting the MDL04 to MDL00 bits.	p. 278 <input type="checkbox"/>	
				The baud rate value is the output clock of the 5-bit counter divided by 2.	p. 278 <input type="checkbox"/>	
			Soft	POWER0, TXE0, RXE0: Bits 7, 6, 5 of ASIM0	Clear POWER0 to 0 after clearing TXE0 and RXE0 to 0 to set the operation stop mode.	p. 279 <input type="checkbox"/>
					To start the communication, set POWER0 to 1, and then set TXE0 or RXE0 to 1.	
				UART mode	Take relationship with the other party of communication when setting the port mode register and port register.	p. 280 <input type="checkbox"/>

APPENDIX D LIST OF CAUTIONS

(14/24)

Chapter	Classification	Function	Details of Function	Cautions	Page
Chapter 11	Soft	Serial interface UART0	UART transmission	After transmit data is written to TXS0, do not write the next transmit data before the transmission completion interrupt signal (INTST0) is generated.	p. 283 <input type="checkbox"/>
			UART reception	If a reception error occurs, read asynchronous serial interface reception error status register 0 (ASIS0) and then read receive buffer register 0 (RXB0) to clear the error flag. Otherwise, an overrun error will occur when the next data is received, and the reception error status will persist.	p. 284 <input type="checkbox"/>
			UART reception	Reception is always performed with the "number of stop bits = 1". The second stop bit is ignored.	p. 284 <input type="checkbox"/>
			Error of baud rate	Keep the baud rate error during transmission to within the permissible error range at the reception destination.	p. 288 <input type="checkbox"/>
				Make sure that the baud rate error during reception satisfies the range shown in (4) Permissible baud rate range during reception.	p. 288 <input type="checkbox"/>
Permissible baud rate range during reception	Make sure that the baud rate error during reception is within the permissible error range, by using the calculation expression shown below.	p. 290 <input type="checkbox"/>			
Chapter 12	Soft	Serial interface UART6	UART mode	The TxD6 output inversion function inverts only the transmission side and not the reception side. To use this function, the reception side must be ready for reception of inverted data.	p. 292 <input type="checkbox"/>
				If clock supply to serial interface UART6 is not stopped (e.g., in the HALT mode), normal operation continues. If clock supply to serial interface UART6 is stopped (e.g., in the STOP mode), each register stops operating, and holds the value immediately before clock supply was stopped. The TxD6 pin also holds the value immediately before clock supply was stopped and outputs it. However, the operation is not guaranteed after clock supply is resumed. Therefore, reset the circuit so that POWER6 = 0, RXE6 = 0, and TXE6 = 0.	p. 292 <input type="checkbox"/>
				Set POWER6 = 1 and then set TXE6 = 1 (transmission) or RXE6 = 1 (reception) to start communication.	p. 292 <input type="checkbox"/>
				TXE6 and RXE6 are synchronized by the base clock (f _{CLK6}) set by CKSR6. To enable transmission or reception again, set TXE6 or RXE6 to 1 at least two clocks of the base clock after TXE6 or RXE6 has been cleared to 0. If TXE6 or RXE6 is set within two clocks of the base clock, the transmission circuit or reception circuit may not be initialized.	p. 292 <input type="checkbox"/>
				Set transmit data to TXB6 at least one base clock (f _{CLK6}) after setting TXE6 = 1.	p. 292 <input type="checkbox"/>
				If data is continuously transmitted, the communication timing from the stop bit to the next start bit is extended two operating clocks of the macro. However, this does not affect the result of communication because the reception side initializes the timing when it has detected a start bit. Do not use the continuous transmission function if the interface is used in LIN communication operation.	p. 292 <input type="checkbox"/>
				TXB6: Transmit buffer register 6	Do not write data to TXB6 when bit 1 (TXBF6) of asynchronous serial interface transmission status register 6 (ASIF6) is 1.
			Do not refresh (write the same value to) TXB6 by software during a communication operation (when bits 7 and 6 (POWER6, TXE6) of asynchronous serial interface operation mode register 6 (ASIM6) are 1 or when bits 7 and 5 (POWER6, RXE6) of ASIM6 are 1).		p. 298 <input type="checkbox"/>
			Set transmit data to TXB6 at least one base clock (f _{CLK6}) after setting TXE6 = 1.		p. 298 <input type="checkbox"/>
			ASIM6: Asynchronous serial interface operation mode register 6	To start the transmission, set POWER6 to 1 and then set TXE6 to 1. To stop the transmission, clear TXE6 to 0, and then clear POWER6 to 0.	p. 300 <input type="checkbox"/>
				To start the reception, set POWER6 to 1 and then set RXE6 to 1. To stop the reception, clear RXE6 to 0, and then clear POWER6 to 0.	p. 300 <input type="checkbox"/>
				Set POWER6 to 1 and then set RXE6 to 1 while a high level is input to the RxD6 pin. If POWER6 is set to 1 and RXE6 is set to 1 while a low level is input, reception is started.	p. 300 <input type="checkbox"/>

Chapter	Classification	Function	Details of Function	Caution	Page
Chapter 12	Soft	Serial interface UART6	ASIM6: Asynchronous serial interface operation mode register 6	TXE6 and RXE6 are synchronized by the base clock (fxCLK6) set by CKSR6. To enable transmission or reception again, set TXE6 or RXE6 to 1 at least two clocks of the base clock after TXE6 or RXE6 has been cleared to 0. If TXE6 or RXE6 is set within two clocks of the base clock, the transmission circuit or reception circuit may not be initialized.	p. 300 <input type="checkbox"/>
				Set transmit data to TXB6 at least one base clock (fxCLK6) after setting TXE6 = 1.	p. 300 <input type="checkbox"/>
				Clear the TXE6 and RXE6 bits to 0 before rewriting the PS61, PS60, and CL6 bits.	p. 300 <input type="checkbox"/>
				Fix the PS61 and PS60 bits to 0 when used in LIN communication operation.	p. 300 <input type="checkbox"/>
				Clear TXE6 to 0 before rewriting the SL6 bit. Reception is always performed with "the number of stop bits = 1", and therefore, is not affected by the set value of the SL6 bit.	p. 300 <input type="checkbox"/>
				Make sure that RXE6 = 0 when rewriting the ISRM6 bit.	p. 300 <input type="checkbox"/>
			ASIS6: Asynchronous serial interface reception error status register 6	The operation of the PE6 bit differs depending on the set values of the PS61 and PS60 bits of asynchronous serial interface operation mode register 6 (ASIM6).	p. 301 <input type="checkbox"/>
				For the stop bit of the receive data, only the first stop bit is checked regardless of the number of stop bits.	p. 301 <input type="checkbox"/>
				If an overrun error occurs, the next receive data is not written to receive buffer register 6 (RXB6) but discarded.	p. 301 <input type="checkbox"/>
				If data is read from ASIS6, a wait cycle is generated. Do not read data from ASIS6 when the CPU is operating on the subsystem clock and the peripheral hardware clock is stopped. For details, see CHAPTER 28 CAUTIONS FOR WAIT.	p. 301 <input type="checkbox"/>
			ASIF6: Asynchronous serial interface transmission status register 6	To transmit data continuously, write the first transmit data (first byte) to the TXB6 register. Be sure to check that the TXBF6 flag is "0". If so, write the next transmit data (second byte) to the TXB6 register. If data is written to the TXB6 register while the TXBF6 flag is "1", the transmit data cannot be guaranteed.	p. 302 <input type="checkbox"/>
				To initialize the transmission unit upon completion of continuous transmission, be sure to check that the TXSF6 flag is "0" after generation of the transmission completion interrupt, and then execute initialization. If initialization is executed while the TXSF6 flag is "1", the transmit data cannot be guaranteed.	p. 302 <input type="checkbox"/>
	CKSR6: Clock selection register 6	Make sure POWER6 = 0 when rewriting TPS63 to TPS60.	p. 303 <input type="checkbox"/>		
		BRGC6: Baud rate generator control register 6	Make sure that bit 6 (TXE6) and bit 5 (RXE6) of the ASIM6 register = 0 when rewriting the MDL67 to MDL60 bits. The baud rate is the output clock of the 8-bit counter divided by 2.	p. 304 <input type="checkbox"/> p. 304 <input type="checkbox"/>	
	Soft	ASICL6: Asynchronous serial interface control register 6	ASICL6 can be refreshed (the same value is written) by software during a communication operation (when bits 7 and 6 (POWER6, TXE6) of ASIM6 = 1 or bits 7 and 5 (POWER6, RXE6) of ASIM6 = 1). However, do not set both SBRT6 and SBTT6 to 1 by a refresh operation during SBF reception (SBRT6 = 1) or SBF transmission (until INTST6 occurs since SBTT6 has been set (1)), because it may re-trigger SBF reception or SBF transmission.	p. 305 <input type="checkbox"/>	
			In the case of an SBF reception error, the mode returns to the SBF reception mode. The status of the SBRF6 flag is held (1).	p. 306 <input type="checkbox"/>	
			Before setting the SBRT6 bit, make sure that bit 7 (POWER6) and bit 5 (RXE6) of ASIM6 = 1. After setting the SBRT6 bit to 1, do not clear it to 0 before SBF reception is completed (before an interrupt request signal is generated).	p. 306 <input type="checkbox"/>	
			The read value of the SBRT6 bit is always 0. SBRT6 is automatically cleared to 0 after SBF reception has been correctly completed.	p. 306 <input type="checkbox"/>	
			Before setting the SBTT6 bit to 1, make sure that bit 7 (POWER6) and bit 6 (TXE6) of ASIM6 = 1. After setting the SBTT6 bit to 1, do not clear it to 0 before SBF transmission is completed (before an interrupt request signal is generated).	p. 306 <input type="checkbox"/>	
			The read value of the SBTT6 bit is always 0. SBTT6 is automatically cleared to 0 at the end of SBF transmission.	p. 306 <input type="checkbox"/>	

Chapter	Classification	Function	Details of Function	Cautions	Page	
Chapter 12	Soft	Serial interface UART6	ASICL6: Asynchronous serial interface control register 6	Do not set the SBRT6 bit to 1 during reception, and do not set the SBTT6 bit to 1 during transmission.	p. 306 <input type="checkbox"/>	
				Before rewriting the DIR6 and TXDLV6 bits, clear the TXE6 and RXE6 bits to 0.	p. 306 <input type="checkbox"/>	
			POWER6, TXE6, RXE6: Bits 7, 6, 5 of ASIM6	Clear POWER6 to 0 after clearing TXE6 and RXE6 to 0 to stop the operation. To start the communication, set POWER6 to 1, and then set TXE6 or RXE6 to 1.	p. 308 <input type="checkbox"/>	
			UART mode	Take relationship with the other party of communication when setting the port mode register and port register.	p. 309 <input type="checkbox"/>	
			Parity types and operation	Fix the PS61 and PS60 bits to 0 when the device is used in LIN communication operation.	p. 312 <input type="checkbox"/>	
			Continuous transmission	The TXBF6 and TXSF6 flags of the ASIF6 register change from "10" to "11", and to "01" during continuous transmission. To check the status, therefore, do not use a combination of the TXBF6 and TXSF6 flags for judgment. Read only the TXBF6 flag when executing continuous transmission.	p. 314 <input type="checkbox"/>	
				When the device is use in LIN communication operation, the continuous transmission function cannot be used. Make sure that asynchronous serial interface transmission status register 6 (ASIF6) is 00H before writing transmit data to transmit buffer register 6 (TXB6).	p. 314 <input type="checkbox"/>	
				To transmit data continuously, write the first transmit data (first byte) to the TXB6 register. Be sure to check that the TXBF6 flag is "0". If so, write the next transmit data (second byte) to the TXB6 register. If data is written to the TXB6 register while the TXBF6 flag is "1", the transmit data cannot be guaranteed.	p. 314 <input type="checkbox"/>	
				To initialize the transmission unit upon completion of continuous transmission, be sure to check that the TXSF6 flag is "0" after generation of the transmission completion interrupt, and then execute initialization. If initialization is executed while the TXSF6 flag is "1", the transmit data cannot be guaranteed.	p. 314 <input type="checkbox"/>	
				During continuous transmission, the next transmission may complete before execution of INTST6 interrupt servicing after transmission of one data frame. As a countermeasure, detection can be performed by developing a program that can count the number of transmit data and by referencing the TXSF6 flag.	p. 314 <input type="checkbox"/>	
				Normal reception	If a reception error occurs, read ASIS6 and then RXB6 to clear the error flag. Otherwise, an overrun error will occur when the next data is received, and the reception error status will persist.	p. 318 <input type="checkbox"/>
					Reception is always performed with the "number of stop bits = 1". The second stop bit is ignored.	p. 318 <input type="checkbox"/>
			Be sure to read asynchronous serial interface reception error status register 6 (ASIS6) before reading RXB6.		p. 318 <input type="checkbox"/>	
			Error of baud rate	Keep the baud rate error during transmission to within the permissible error range at the reception destination.	p. 324 <input type="checkbox"/>	
				Make sure that the baud rate error during reception satisfies the range shown in (4) Permissible baud rate range during reception.	p. 324 <input type="checkbox"/>	
Permissible baud rate range during reception	Make sure that the baud rate error during reception is within the permissible error range, by using the calculation expression shown below.	p. 326 <input type="checkbox"/>				
Chapter 13	Soft	Serial interface CSI10	SOTB10: Transmit buffer register 10	Do not access SOTB10 when CSOT10 = 1 (during serial communication).	p. 331 <input type="checkbox"/>	
			SIO10: Serial I/O shift register 10	Do not access SIO10 when CSOT10 = 1 (during serial communication).	p. 331 <input type="checkbox"/>	
			CSIM10: Serial operation mode register 10	Be sure to clear bit 5 and 3 through 1 to 0.	p. 332 <input type="checkbox"/>	

Chapter	Classification	Function	Details of Function	Cautions	Page
Chapter 13	Soft	Serial interface CSI10	CSIC10: Serial clock selection register 10	Do not write to CSIC10 while CSIE10 = 1 (operation enabled).	p. 333 <input type="checkbox"/>
				To use P10/SCK10/TxD0 and P12/SO10 as general-purpose ports, set CSIC10 in the default status (00H).	p. 333 <input type="checkbox"/>
				The phase type of the data clock is type 1 after reset.	p. 333 <input type="checkbox"/>
			3-wire serial I/O mode	Take relationship with the other party of communication when setting the port mode register and port register.	p. 336 <input type="checkbox"/>
			Communication operation	Do not access the control register and data register when CSOT10 = 1 (during serial communication).	p. 337 <input type="checkbox"/>
		SO10 output	If a value is written to TRMD10, DAP10, and DIR10, the output value of SO10 changes.	p. 345 <input type="checkbox"/>	
Chapter 14	Soft	Serial interface IIC0	IIC0: IIC shift register 0	Do not write data to IIC0 during data transfer.	p. 349 <input type="checkbox"/>
				Write or read IIC0 only during the wait period. Accessing IIC0 in a communication state other than during the wait period is prohibited. When the device serves as the master, however, IIC0 can be written only once after the communication trigger bit (STT0) is set to 1.	p. 349 <input type="checkbox"/>
			IICC0: IIC control register 0	The start condition is detected immediately after I ² C is enabled to operate (IICE0 = 1) while the SCL0 line is at high level and the SDA0 line is at low level. Immediately after enabling I ² C to operate (IICE0 = 1), set LRELO (1) by using a 1-bit memory manipulation instruction.	p. 353 <input type="checkbox"/>
				When bit 3 (TRC0) of IIC status register 0 (IICS0) is set to 1, WRELO is set to 1 during the ninth clock and wait is canceled, after which TRC0 is cleared and the SDA0 line is set to high impedance.	p. 356 <input type="checkbox"/>
			IICS0: IIC status register 0	If data is read from IICS0, a wait cycle is generated. For details, see CHAPTER 26 CAUTIONS FOR WAIT.	p. 357 <input type="checkbox"/>
			IICF0: IIC flag register 0	Write to STCEN only when the operation is stopped (IICE0 = 0).	p. 360 <input type="checkbox"/>
				As the bus release status (IICBSY = 0) is recognized regardless of the actual bus status when STCEN = 1, when generating the first start condition (STT0 = 1), it is necessary to verify that no third party communications are in progress in order to prevent such communications from being destroyed.	p. 360 <input type="checkbox"/>
				Write to IICRSV only when the operation is stopped (IICE0 = 0).	p. 360 <input type="checkbox"/>
Selection clock setting	Determine the transfer clock frequency of I ² C by using CLX0, SMC0, CL01, and CL00 before enabling the operation (by setting bit 7 (IICE0) of IIC control register 0 (IICC0) to 1). To change the transfer clock frequency, clear IICE0 once to 0.	p. 363 <input type="checkbox"/>			
When STCEN = 0	Immediately after I ² C operation is enabled (IICE0 = 1), the bus communication status (IICBSY (bit 6 of IICF0) = 1) is recognized regardless of the actual bus status. When changing from a mode in which no stop condition has been detected to a master device communication mode, first generate a stop condition to release the bus, then perform master device communication. When using multiple masters, it is not possible to perform master device communication when the bus has not been released (when a stop condition has not been detected). Use the following sequence for generating a stop condition. <ul style="list-style-type: none"> • Set IIC clock selection register 0 (IICCL0). • Set bit 7 (IICE0) of IIC control register 0 (IICC0) to 1. • Set bit 0 (SPT0) of IICC0 to 1. 	p. 380 <input type="checkbox"/>			
When STCEN = 1	Immediately after I ² C operation is enabled (IICE0 = 1), the bus released status (IICBSY = 0) is recognized regardless of the actual bus status. To generate the first start condition (STT0 (bit 1 of IIC control register 0 (IICC0)) = 1), it is necessary to confirm that the bus has been released, so as to not disturb other communications.	p. 380 <input type="checkbox"/>			

Chapter	Classification	Function	Details of Function	Cautions	Page
Chapter 14	Soft	Serial interface IIC0	If other I ² C communications are already in progress	If I ² C operation is enabled and the device participates in communication already in progress when the SDA0 pin is low and the SCL0 pin is high, the macro of I ² C recognizes that the SDA0 pin has gone low (detects a start condition). If the value on the bus at this time can be recognized as an extension code, ACK is returned, but this interferes with other I ² C communications. To avoid this, start I ² C in the following sequence. <1> Clear bit 4 (SPIE0) of IICC0 to 0 to disable generation of an interrupt request signal (INTIIC0) when the stop condition is detected. <2> Set bit 7 (IICE0) of IICC0 to 1 to enable the operation of I ² C. <3> Wait for detection of the start condition. <4> Set bit 6 (LRELO) of IICC0 to 1 before ACK is returned (4 to 80 clocks after setting IICE0 to 1), to forcibly disable detection.	p. 380 <input type="checkbox"/>
			Transfer clock frequency setting	Determine the transfer clock frequency by using SMC0, CL01, CL00 (bits 3, 1, and 0 of IICL0), and CLX0 (bit 0 of IICX0) before enabling the operation (IICE0 = 1). To change the transfer clock frequency, clear IICE0 to 0 once.	p. 380 <input type="checkbox"/>
			STT0, SPT0: Bits 1, 0 of IIC control register 0 (IICC0)	Setting STT0 and SPT0 (bits 1 and 0 of IICC0) again after they are set and before they are cleared to 0 is prohibited.	p. 381 <input type="checkbox"/>
			Transmission reserve	When transmission is reserved, set SPIE0 (bit 4 of IICL0) to 1 so that an interrupt request is generated when the stop condition is detected. Transfer is started when communication data is written to IIC0 after the interrupt request is generated. Unless the interrupt is generated when the stop condition is detected, the device stops in the wait state because the interrupt request is not generated when communication is started. However, it is not necessary to set SPIE0 to 1 when MSTSO (bit 7 of IICS0) is detected by software.	p. 381 <input type="checkbox"/>
Chapter 15	Soft	Interrupt function	1F0L, 1F0H, 1F1L, 1F1H: Interrupt request flag registers	Be sure to clear bits 2, 4 to 7 of IF1L and bits 1 to 7 of IF1H to 0.	p. 422 <input type="checkbox"/>
				When operating a timer, serial interface, or A/D converter after standby release, operate it once after clearing the interrupt request flag. An interrupt request flag may be set by noise.	p. 422 <input type="checkbox"/>
				When manipulating a flag of the interrupt request flag register, use a 1-bit memory manipulation instruction (CLR1). When describing in C language, use a bit manipulation instruction such as "IF0L.0 = 0;" or "_asm("clr1 IF0L, 0");" because the compiled assembler must be a 1-bit memory manipulation instruction (CLR1). If a program is described in C language using an 8-bit memory manipulation instruction such as "IF0L &= 0xfe;" and compiled, it becomes the assembler of three instructions. <pre>mov a, IF0L and a, #0FEH mov IF0L, a</pre> In this case, even if the request flag of another bit of the same interrupt request flag register (IF0L) is set to 1 at the timing between "mov a, IF0L" and "mov IF0L, a", the flag is cleared to 0 at "mov IF0L, a". Therefore, care must be exercised when using an 8-bit memory manipulation instruction in C language.	p. 423 <input type="checkbox"/>
			MK0L, MK0H, MK1L, MK1H: Interrupt mask flag registers	Be sure to set bits 2, 4 to 7 of MK1L and bits 1 to 7 of MK1H to 1.	p. 424 <input type="checkbox"/>
		PROL, PROH, PR1L, PR1H: Priority specification flag registers	Be sure to set bits 2, 4 to 7 of PR1L and bits 1 to 7 of PR1H to 1.	p. 425 <input type="checkbox"/>	

Chapter	Chapter Classification	Function	Details of Function	Cautions	Page	
Chapter 15	Soft	Interrupt function	EGP, EGN: External interrupt rising edge, falling edge enable registers	Select the port mode by clearing EGPn and EGNn to 0 because an edge may be detected when the external interrupt function is switched to the port function.	p. 426 <input type="checkbox"/>	
			Software interrupt request	Do not use the RETI instruction for restoring from the software interrupt.	p. 430 <input type="checkbox"/>	
			BRK instruction	The BRK instruction is not one of the above-listed interrupt request hold instructions. However, the software interrupt activated by executing the BRK instruction causes the IE flag to be cleared. Therefore, even if a maskable interrupt request is generated during execution of the BRK instruction, the interrupt request is not acknowledged.	p. 434 <input type="checkbox"/>	
Chapter 16	Soft	Standby function	Standby function	When shifting to the STOP mode, be sure to stop the peripheral hardware operation operating with main system clock before executing STOP instruction.	p. 435 <input type="checkbox"/>	
				The following sequence is recommended for operating current reduction of the A/D converter when the standby function is used: First clear bit 7 (ADCS) and bit 0 (ADCE) of the A/D converter mode register (ADM) to 0 to stop the A/D conversion operation, and then execute the STOP instruction.	p. 435 <input type="checkbox"/>	
			OSTC: Oscillation stabilization time counter status register	After the above time has elapsed, the bits are set to 1 in order from MOST11 and remain 1.	p. 436 <input type="checkbox"/>	
				The oscillation stabilization time counter counts up to the oscillation stabilization time set by OSTs. If the STOP mode is entered and then released while the internal high-speed oscillation clock is being used as the CPU clock, set the oscillation stabilization time as follows. • Desired OSTC oscillation stabilization time ≤ Oscillation stabilization time set by OSTs Note, therefore, that only the status up to the oscillation stabilization time set by OSTs is set to OSTC after STOP mode is released.	p. 436 <input type="checkbox"/>	
	Hard			The X1 clock oscillation stabilization wait time does not include the time until clock oscillation starts ("a" below).	p. 436 <input type="checkbox"/>	
	Soft			OSTS: Oscillation stabilization time select register	To set the STOP mode when the X1 clock is used as the CPU clock, set OSTs before executing the STOP instruction.	p. 437 <input type="checkbox"/>
					Do not change the value of the OSTs register during the X1 clock oscillation stabilization time.	p. 437 <input type="checkbox"/>
					The oscillation stabilization time counter counts up to the oscillation stabilization time set by OSTs. If the STOP mode is entered and then released while the internal high-speed oscillation clock is being used as the CPU clock, set the oscillation stabilization time as follows. • Desired OSTC oscillation stabilization time ≤ Oscillation stabilization time set by OSTs Note, therefore, that only the status up to the oscillation stabilization time set by OSTs is set to OSTC after STOP mode is released.	p. 437 <input type="checkbox"/>
					The X1 clock oscillation stabilization wait time does not include the time until clock oscillation starts ("a" below).	p. 437 <input type="checkbox"/>
Hard				The X1 clock oscillation stabilization wait time does not include the time until clock oscillation starts ("a" below).	p. 437 <input type="checkbox"/>	

APPENDIX D LIST OF CAUTIONS

(20/24)

Chapter	Classification	Function	Details of Function	Cautions	Page	
Chapter 16	Soft	Standby function	STOP mode	Because the interrupt request signal is used to clear the standby mode, if there is an interrupt source with the interrupt request flag set and the interrupt mask flag reset, the standby mode is immediately cleared if set. Thus, the STOP mode is reset to the HALT mode immediately after execution of the STOP instruction and the system returns to the operating mode as soon as the wait time set using the oscillation stabilization time select register (OSTS) has elapsed.	p. 442 <input type="checkbox"/>	
				To use the peripheral hardware that stops operation in the STOP mode, and the peripheral hardware for which the clock that stops oscillating in the STOP mode after the STOP mode is released, restart the peripheral hardware.	p. 444 <input type="checkbox"/>	
				Even if "internal low-speed oscillator can be stopped by software" is selected by the option byte, the internal low-speed oscillation clock continues in the STOP mode in the status before the STOP mode is set. To stop the internal low-speed oscillator's oscillation in the STOP mode, stop it by software and then execute the STOP instruction.	p. 444 <input type="checkbox"/>	
				To shorten oscillation stabilization time after the STOP mode is released when the CPU operates with the high-speed system clock (X1 oscillation), temporarily switch the CPU clock to the internal high-speed oscillation clock before the next execution of the STOP instruction. Before changing the CPU clock from the internal high-speed oscillation clock to the high-speed system clock (X1 oscillation) after the STOP mode is released, check the oscillation stabilization time with the oscillation stabilization time counter status register (OSTC).	p. 444 <input type="checkbox"/>	
				If the STOP instruction is executed when AMPH = 1, supply of the CPU clock is stopped for 4.06 to 16.12 μ s after the STOP mode is released when the internal high-speed oscillation clock is selected as the CPU clock, or for the duration of 160 external clocks when the high-speed system clock (external clock input) is selected as the CPU clock.	p. 444 <input type="checkbox"/>	
Chapter 17	Hard	Reset function	-	For an external reset, input a low level for 10 μ s or more to the RESET pin.	p. 448 <input type="checkbox"/>	
				During reset input, the X1 clock, XT1 clock, internal high-speed oscillation clock, and internal low-speed oscillation clock stop oscillating. External main system clock input and external subsystem clock input become invalid.	p. 448 <input type="checkbox"/>	
				When the STOP mode is released by a reset, the STOP mode contents are held during reset input. However, the port pins become high-impedance.	p. 448 <input type="checkbox"/>	
				Block diagram of reset function	An LVI circuit internal reset does not reset the LVI circuit.	p. 449 <input type="checkbox"/>
				Watchdog timer overflow	A watchdog timer internal reset resets the watchdog timer.	p. 450 <input type="checkbox"/>
	Soft	RESF: Reset control flag register	Do not read data by a 1-bit memory manipulation instruction.	p. 456 <input type="checkbox"/>		
Chapter 18	Soft	Power-on-clear circuit	-	If an internal reset signal is generated in the POC circuit, the reset control flag register (RESF) is cleared to 00H.	p. 457 <input type="checkbox"/>	
				Set the low-voltage detector by software after the reset status is released (see CHAPTER 19 LOW-VOLTAGE DETECTOR).	pp. 459 <input type="checkbox"/> 460	
				In 2.7 V/1.59 V POC mode	A voltage oscillation stabilization time of 1.93 to 5.39 ms is required after the power supply voltage reaches 1.59 V (TYP.). If the supply voltage rises from 1.59 V (TYP.) to 2.7 V (TYP.) within 1.93 ms, the power supply oscillation stabilization time of 0 to 5.39 ms is automatically generated before reset processing.	p. 460 <input type="checkbox"/>
				Cautions for power-on-clear circuit	In a system where the supply voltage (V_{DD}) fluctuates for a certain period in the vicinity of the POC detection voltage (V_{POC}), the system may be repeatedly reset and released from the reset status. In this case, the time from release of reset to the start of the operation of the microcontroller can be arbitrarily set by taking the following action.	p. 461 <input type="checkbox"/>

Chapter	Classification	Function	Details of Function	Cautions	Page
Chapter 19	Soft	Low-voltage detector	LVIM: Low-voltage detection register	To stop LVI, follow either of the procedures below. <ul style="list-style-type: none"> When using 8-bit memory manipulation instruction: Write 00H to LVIM. When using 1-bit memory manipulation instruction: Clear LVION to 0. 	p. 465 <input type="checkbox"/>
				Input voltage from external input pin (EXLVI) must be $EXLVI < V_{DD}$.	p. 465 <input type="checkbox"/>
	Soft		LVIS: Low-voltage detection level selection register	Be sure to clear bits 4 to 7 to "0".	p. 466 <input type="checkbox"/>
				Do not change the value of LVIS during LVI operation.	p. 466 <input type="checkbox"/>
				When an input voltage from the external input pin (EXLVI) is detected, the detection voltage ($V_{EXLVI} = 1.21 \text{ V (TYP.)}$) is fixed. Therefore, setting of LVIS is not necessary.	p. 466 <input type="checkbox"/>
	Hard		When detecting level of supply voltage (V_{DD})	<1> must always be executed. When LVIMK = 0, an interrupt may occur immediately after the processing in <4>.	p. 468 <input type="checkbox"/>
				If supply voltage (V_{DD}) \geq detection voltage (V_{LVI}) when LVIMD is set to 1, an internal reset signal is not generated.	p. 468 <input type="checkbox"/>
				<1> must always be executed. When LVIMK = 0, an interrupt may occur immediately after the processing in <3>.	p. 471 <input type="checkbox"/>
				If input voltage from external input pin (EXLVI) \geq detection voltage ($V_{EXLVI} = 1.21 \text{ V (TYP.)}$) when LVIMD is set to 1, an internal reset signal is not generated.	p. 471 <input type="checkbox"/>
	Hard		When detecting level of input voltage from external input pin (EXLVI)	Input voltage from external input pin (EXLVI) must be $EXLVI < V_{DD}$.	p. 471 <input type="checkbox"/>
When detecting level of input voltage from external input pin (EXLVI)		Input voltage from external input pin (EXLVI) must be $EXLVI < V_{DD}$.		p. 476 <input type="checkbox"/>	
Soft	When detecting level of input voltage from external input pin (EXLVI)	Caution for low-voltage detector In a system where the supply voltage (V_{DD}) fluctuates for a certain period in the vicinity of the LVI detection voltage (V_{LVI}), the operation is as follows depending on how the low-voltage detector is used. (1) When used as reset The system may be repeatedly reset and released from the reset status. In this case, the time from release of reset to the start of the operation of the microcontroller can be arbitrarily set by taking action (1) below. (2) When used as interrupt Interrupt requests may be frequently generated. Take (b) of action (2) below.	p. 478 <input type="checkbox"/>		
Chapter 20	Soft	Option byte	0082H, 0083H/1082H, 1083H	Be sure to set 00H to 0082H and 0083H (0082H/1082H and 0083H/1083H when the boot swap function is used).	p. 481 <input type="checkbox"/>
			0080H/1080H	Set a value that is the same as that of 0080H to 1080H because 0080H and 1080H are switched during the boot swap operation.	p. 481 <input type="checkbox"/>
			0081H/1081H	POCMODE can only be written by using a dedicated flash memory programmer. It cannot be set during self-programming or boot swap operation during self-programming (at this time, 1.59 V POC mode (default) is set). However, because the value of 1081H is copied to 0081H during the boot swap operation, it is recommended to set a value that is the same as that of 0081H to 1081H when the boot swap function is used.	p. 481 <input type="checkbox"/>
			0084H/1084H	Be sure to set 00H (disabling on-chip debug operation) to 0084H for products not equipped with the on-chip debug function (μ PD78F0500, 78F0501, 78F0502, and 78F0503). Also set 00H to 1084H because 0084H and 1084H are switched at boot swapping.	p. 482 <input type="checkbox"/>
				To use the on-chip debug function with a product equipped with the on-chip debug function (μ PD78F0503D), set 02H or 03H to 0084H. Set a value that is the same as that of 0084H to 1084H because 0084H and 1084H are switched at boot swapping.	p. 482 <input type="checkbox"/>

APPENDIX D LIST OF CAUTIONS

(22/24)

Chapter	Classification	Function	Details of Function	Cautions	Page	
Chapter 20	Soft	Option byte	0080H/1080H	The combination of WDCS2 = WDCS1 = WDCS0 = 0 and WINDOW1 = WINDOW0 = 0 is prohibited.	p. 483 <input type="checkbox"/>	
				The watchdog timer continues its operation during self-programming and EEPROM emulation of the flash memory. During processing, the interrupt acknowledge time is delayed. Set the overflow time and window size taking this delay into consideration.	p. 483 <input type="checkbox"/>	
				If LSROSC = 0 (oscillation can be stopped by software), the count clock is not supplied to the watchdog timer in the HALT and STOP modes, regardless of the setting of bit 0 (LSRSTOP) of the internal oscillation mode register (RCM). When 8-bit timer H1 operates with the internal low-speed oscillation clock, the count clock is supplied to 8-bit timer H1 even in the HALT/STOP mode.	p. 483 <input type="checkbox"/>	
				Be sure to clear bit 7 to 0.	p. 483 <input type="checkbox"/>	
			0081H/1081H	Be sure to clear bits 7 to 1 to "0".	p. 484 <input type="checkbox"/>	
Chapter 21	Soft	Flash memory	IMS: Internal memory size switching register, IXS: internal expansion RAM size switching register	Be sure to set each product to the values shown in Table 21-1 after a reset release.	p. 486 <input type="checkbox"/>	
				Operation clock	Only the internal high-speed oscillation clock (f_{RH}) can be used when CSI10 is used.	p. 494 <input type="checkbox"/>
					Only the X1 clock (f_x) or external main system clock (f_{EXCLK}) can be used when UART6 is used.	p. 494 <input type="checkbox"/>
				Processing of X1, P31 pins	For the product with an on-chip debug function (μ PD78F0503D), connect P31/INTP2/OCD1A and P121/X1/OCD0A as follows when writing the flash memory with a flash memory programmer. <ul style="list-style-type: none"> P31/INTP2/OCD1A: Connect to V_{SS} via a resistor (10 kΩ: recommended). P121/X1/OCD0A: When using this pin as a port, connect it to V_{SS} via a resistor (10 kΩ: recommended) (in the input mode) or leave it open (in the output mode). The above connection is not necessary when writing the flash memory by means of self programming.	p. 495 <input type="checkbox"/>
				Selecting communication mode	When UART6 is selected, the receive clock is calculated based on the reset command sent from the dedicated flash memory programmer after the FLMD0 pulse has been received.	p. 497 <input type="checkbox"/>
	Hard	Security Settings	After the security setting for the batch erase is set, erasure cannot be performed for the device. In addition, even if a write command is executed, data different from that which has already been written to the flash memory cannot be written, because the erase command is disabled.	p. 499 <input type="checkbox"/>		
			If a security setting that rewrites boot cluster 0 has been applied, boot cluster 0 of that device will not be rewritten.	p. 499 <input type="checkbox"/>		
Soft	Flash memory programming by self-programming	Input a high level to the FLMD0 pin during self-programming.	p. 502 <input type="checkbox"/>			
		Be sure to execute the DI instruction before starting self-programming. The self-programming function checks the interrupt request flags (IF0L, IF0H, IF1L, and IF1H). If an interrupt request is generated, self-programming is stopped.	p. 502 <input type="checkbox"/>			
		Self-programming is also stopped by an interrupt request that is not masked even in the DI status. To prevent this, mask the interrupt by using the interrupt mask flag registers (MK0L, MK0H, MK1L, and MK1H).	p. 502 <input type="checkbox"/>			

Chapter	Classification	Function	Details of Function	Cautions	Page
Chapter 22	Hard	On-chip debug function (μ PD78F0513D and 78F0515D only)	μ PD78F0503D	The μ PD78F0503D has an on-chip debug function. Do not use these products for mass production because its reliability cannot be guaranteed after the on-chip debug function has been used, given the issue of the number of times the flash memory can be rewritten. NEC Electronics does not accept complaints concerning these products.	p. 510 <input type="checkbox"/>
			When OCD0A/X1 and OCD0B/X2 are used	Input the clock from the OCD0A/X1 pin during on-chip debugging.	p. 510 <input type="checkbox"/>
				Control the OCD0A/X1 and OCD0B/X2 pins by externally pulling down the OCD1A/P31 pin.	p. 510 <input type="checkbox"/>
Chapter 24	Hard	Electrical specifications (standard products)	μ PD78F0503D	The μ PD78F0503D has an on-chip debug function. Do not use this product for mass production because its reliability cannot be guaranteed after the on-chip debug function has been used, given the issue of the number of times the flash memory can be rewritten. NEC Electronics does not accept complaints concerning these products.	p. 526 <input type="checkbox"/>
			Absolute maximum ratings	Product quality may suffer if the absolute maximum rating is exceeded even momentarily for any parameter. That is, the absolute maximum ratings are rated values at which the product is on the verge of suffering physical damage, and therefore the product must be used under conditions that ensure that the absolute maximum ratings are not exceeded.	pp. 526 527
			X1 oscillator characteristics	When using the X1 oscillator, wire as follows in the area enclosed by the broken lines in the above figures to avoid an adverse effect from wiring capacitance. <ul style="list-style-type: none"> • Keep the wiring length as short as possible. • Do not cross the wiring with the other signal lines. • Do not route the wiring near a signal line through which a high fluctuating current flows. • Always make the ground point of the oscillator capacitor the same potential as V_{SS}. • Do not ground the capacitor to a ground pattern through which a high current flows. • Do not fetch signals from the oscillator. 	p. 528 <input type="checkbox"/>
				Since the CPU is started by the internal high-speed oscillation clock after a reset release, check the X1 clock oscillation stabilization time using the oscillation stabilization time counter status register (OSTC) by the user. Determine the oscillation stabilization time of the OSTC register and oscillation stabilization time select register (OSTS) after sufficiently evaluating the oscillation stabilization time with the resonator to be used.	p. 528 <input type="checkbox"/>
			Oscillator constants	The oscillator constants shown above are reference values based on evaluation in a specific environment by the resonator manufacturer. If it is necessary to optimize the oscillator characteristics in the actual application, apply to the resonator manufacturer for evaluation on the implementation circuit. The oscillation voltage and oscillation frequency only indicate the oscillator characteristic. Use the 78K0/KB2 so that the internal operation conditions are within the specifications of the DC and AC characteristics.	pp. 529 530 <input type="checkbox"/>
Chapter 25	Hard	Electrical specifications ((A) grade products, target)	Absolute maximum ratings	Product quality may suffer if the absolute maximum rating is exceeded even momentarily for any parameter. That is, the absolute maximum ratings are rated values at which the product is on the verge of suffering physical damage, and therefore the product must be used under conditions that ensure that the absolute maximum ratings are not exceeded.	pp. 545 546 <input type="checkbox"/>

APPENDIX D LIST OF CAUTIONS

(24/24)

Chapter	Classification	Function	Details of Function	Cautions	Page
Chapter 25	Hard	Electrical specifications ((A) grade products, target)	X1 oscillator characteristics	<p>When using the X1 oscillator, wire as follows in the area enclosed by the broken lines in the above figures to avoid an adverse effect from wiring capacitance.</p> <ul style="list-style-type: none"> • Keep the wiring length as short as possible. • Do not cross the wiring with the other signal lines. • Do not route the wiring near a signal line through which a high fluctuating current flows. • Always make the ground point of the oscillator capacitor the same potential as V_{SS}. • Do not ground the capacitor to a ground pattern through which a high current flows. • Do not fetch signals from the oscillator. 	p.547 <input type="checkbox"/>
			X1 oscillator characteristics	<p>Since the CPU is started by the internal high-speed oscillation clock after a reset release, check the X1 clock oscillation stabilization time using the oscillation stabilization time counter status register (OSTC) by the user. Determine the oscillation stabilization time of the OSTC register and oscillation stabilization time select register (OSTS) after sufficiently evaluating the oscillation stabilization time with the resonator to be used.</p>	p. 547 <input type="checkbox"/>
Chapter 27	Hard	Recommended soldering conditions	-	Do not use different soldering methods together (except for partial heating).	p. 567 <input type="checkbox"/>

APPENDIX E REVISION HISTORY

E.1 Major Revisions in This Edition

(1/6)

Page	Description	Classification
Throughout	Addition of (A) standard products μ PD78F0500MC(A)-CAB-AX, 78F0501MC(A)-CAB-AX, 78F0502MC(A)-CAB-AX, 78F0503MC(A)-CAB-AX	(d)
	Partial change of description of how to make connections for P31/INTP2/OCD1A and P121/X1/OCD0A pins when writing the flash memory with a flash memory programmer	(a)
	Extending value range of capacitor (“0.47 μ F: target” → “0.47 to 1 μ F: recommended)	(b)
	Change of power supply voltage inclination t_{PTH} from “0.5 V/ms (MAX.)” to “0.5 V/ms (MIN.)”	(b)
INTRODUCTION		
pp. 7, 8	Addition of following related documents of device <ul style="list-style-type: none"> • 78K0/Kx2 Flash Memory Programming (Programmer) Application Note • 78K0/Kx2 Flash Memory Self Programming User’s Manual • PG-FPL3 Flash Memory Programmer User’s Manual 	(e)
CHAPTER 1 OUTLINE		
p. 16	Deletion of description concerning production process division management from 1.1 Features	(d)
p. 18	Change of 1.3 Ordering Information	(d)
pp. 19, 20	Change of following contents to 1.4 Pin Configuration (Top View) <ul style="list-style-type: none"> • Change of Caution 2 to 30-pin plastic SSOP (7.62 mm (300)) • Change of Cautions 1 and 3, and addition of Caution 2 to 36-pin plastic FLGA (4x4) 	(b)
p. 22	Deletion of description concerning production process division management from 1.5 78K0/Kx2 Series Lineup	(d)
p. 27	Deletion of description concerning production process division management from 1.7 Outline of Functions	(d)
CHAPTER 2 PIN FUNCTIONS		
p. 33	Addition of Caution 2 and Note to 2.2.4 P30 to P33 (port 3)	(c)
p. 34	Addition of Caution and Note to 2.2.6 P120 to P122 (port 12)	(c)
pp. 36, 37	Addition of following contents to Table 2-2 Pin I/O Circuit Types <ul style="list-style-type: none"> • Addition of Notes 2 and 3 to P31/INTP2/OCD1A pin • Addition of Note 3 to P32/INTP2/OCD1B pin • Addition of Notes 2 and 5 to P121/X1/OCD0A pin • Addition of Note 4 to FLMD0 pin • Addition of connection of RESET pin when not used 	(a), (c)
CHAPTER 3 CPU ARCHITECTURE		
pp. 41 to 45	Addition of Remark and block number figure to Figures 3-1 Memory Map (μPD78F0500) to 3-5 Memory Map (μPD78F0503D)	(c)
p. 46	Addition of Table 3-2 Correspondence Between Address Values and Block Numbers of Flash Memory	(c)
CHAPTER 4 PORT FUNCTIONS		
p. 83	Change of setting of digital input and output in Table 4-4 Setting Functions of P20/ANI0 to P23/ANI3 Pins	(a)

Remark “Classification” in the above table classifies revisions as follows.

- (a): Error correction, (b): Addition/change of specifications, (c): Addition/change of description or note, (d): Addition/change of package, part number, or management division, (e): Addition/change of related documents

Page	Description	Classification
p. 83	Addition of Caution to 4.2.3 Port 2	(c)
p. 84	Addition of Caution 2 and Note to 4.2.4 Port 3	(c)
p. 88	Addition of Caution 2 and Note to 4.2.6 Port 12	(c)
p. 92	Addition of Caution to Figure 4-15 Format of Port Mode Register	(c)
p. 93	Addition of Note to Figure 4-16 Format of Port Register	(c)
p. 98	Change of setting of digital input and output in Table 4-6 Setting Functions of ANI0/P20 to ANI3/P23 Pins	(a)
p. 99	Addition of 4.6 Cautions on 1-Bit Manipulation Instruction for Port Register n (Pn)	(c)
CHAPTER 5 CLOCK GENERATOR		
p. 104	Change of Cautions 2 and 3 (description concerning stopping time of supplying CPU clock) in Figure 5-2 Format of Clock Operation Mode Select Register (OSCCTL)	(b)
p. 111	Addition of description of external clock input to 5.4.1 X1 oscillator	(c)
p. 115	Change of voltage oscillation stabilization time and reset processing time in and addition of Note 1 concerning waiting for oscillation accuracy stabilization to Figure 5-11 Clock Generator Operation When Power Supply Voltage Is Turned On (When 1.59 V POC Mode Is Set (Option Byte: POCMODE = 0))	(b), (c)
p. 116	Addition of Caution 1 and waiting time for oscillation accuracy stabilization to and change of reset processing time in Figure 5-12 Clock Generator Operation When Power Supply Voltage Is Turned On (When 2.7 V/1.59 V POC Mode Is Set (Option Byte: POCMODE = 1))	(c)
pp.117, 118	Partial change (CPU clock supply stop time when AMPH = 1) of Note in 5.6.1 (1) <1> Setting frequency (OSCCTL register) and 5.6.1 (2) <1> Setting frequency (OSCCTL register)	(b)
p. 124	Change of Remark in Figure 5-13 CPU Clock Status Transition Diagram (When 1.59 V POC Mode Is Set (Option Byte: POCMODE = 0))	(c)
p. 127	Change of CPU clock supply stop time when AMPH = 1 in Table 5-5 Changing CPU Clock	(b)
CHAPTER 6 16-BIT TIMER/EVENT COUNTERS 00		
p. 134	Addition of (iii) Setting range when CR000 or CR010 is used as a compare register	(a), (c)
p. 137	Partial change of description of bits 3 and 2 (TMC003, TMC002) in Figure 6-5 Format of 16-Bit Timer Mode Control Register 00 (TMC00)	(c)
p. 147	Change of (c) 16-bit timer output control register 00 (TOC00) of Figure 6-17 Example of Register Settings for Square Wave Output Operation	(a)
p. 148	Change of timing chart in Figure 6-18 Example of Software Processing for Square-Wave Output Function	(a)
p. 150	Change of (c) 16-bit timer output control register 00 (TOC00) of Figure 6-20 Example of Register Settings in External Event Counter Mode	(a)
p. 152	Change of Figure 6-21 Example of Software Processing in External Event Counter Mode	(a)
p. 168	Change of Figure 6-35 Timing Example of Free-Running Timer Mode (CR000: Compare Register, CR010: Capture Register) (change of figure to that where CR000 = 0000H)	(c)
p. 176	Change of Caution in Figure 6-41 Example of Register Settings for PPG Output Operation	(a)
p. 180	Change of Caution in Figure 6-44 Example of Register Settings for One-Shot Pulse Output Operation	(a)

Remark "Classification" in the above table classifies revisions as follows.

- (a): Error correction, (b): Addition/change of specifications, (c): Addition/change of description or note,
- (d): Addition/change of package, part number, or management division, (e): Addition/change of related documents

Page	Description	Classification
p. 193	Change of restrictions on operations as external event counter, as PPG output, and as one-shot pulse output in Table 6-3 Restrictions for Each Channel of 16-Bit Timer/Event Counter 00	(c)
CHAPTER 7 8-BIT TIMER/EVENT COUNTERS 50 AND 51		
p. 203	Change of Caution 3 in Figure 7-7 Format of 8-Bit Timer Mode Control Register 50 (TMC50) and Figure 7-8 Format of 8-Bit Timer Mode Control Register 51 (TMC51)	(c)
p. 207	Change of set value of TMC5n in Setting <1> in 7.4.2 Operation as external event counter	(a)
CHAPTER 8 8-BIT TIMER/EVENT COUNTERS H0 AND H1		
p. 217	Change of Caution in Figure 8-3 Format of 8-Bit Timer H Compare Register 0n (CMP0n)	(c)
p. 217	Partial addition of description to 8.2 (2) 8-bit timer H compare register 1n (CMP1n)	(c)
pp. 220, 222	Change of Caution 1 of Figure 8-5 Format of 8-Bit Timer H Mode Register 0 (TMHMD0) and Figure 8-6 Format of 8-Bit Timer H Mode Register 1 (TMHMD1)	(c)
p. 222	Partial change of description of RMC1 and NRZB1 bits in and addition of Caution to Figure 8-7 Format of 8-Bit Timer H Carrier Control Register 1 (TMCYC1)	(c)
p. 226	Change of (c) Operation when CMP0n = 00H in Figure 8-10 Timing of Interval Timer/Square-Wave Output Operation	(a)
p. 233	Partial change of description of RMC1 and NRZB1 bits in 8.4.3 (2) Carrier output control	(c)
CHAPTER 10 A/D CONVERTER		
p. 258	Change of setting of digital input and output in Table 10-3 Setting Functions of ANI0/P20 to ANI3/P23 Pins	(a)
CHAPTER 11 SERIAL INTERFACE UART0		
p. 270	Change of maximum transfer rate in 11.1 Functions of Serial Interface UART0	(b)
p. 289	Addition of setting data when target baud rate is 312500 bps and 625000 bps to Table 11-5 Set Data of Baud Rate Generator	(b), (c)
CHAPTER 12 SERIAL INTERFACE UART6		
p. 292	Change of maximum transfer rate in 12.1 Functions of Serial Interface UART6	(b)
p. 304	Change of output clock selection range and Remark 2 in Figure 12-9 Format of Baud Rate Generator Control Register 6 (BRGC6)	(b)
p. 323	Partial change of description in 12.4.3 (2) Generation of serial clock	(b)
p. 325	Addition of data to be set where target baud rate is 625000 bps to and change of Remark in Table 12-5 Set Data of Baud Rate Generator	(b), (c)
p. 327	Addition of error if division ratio (k) is 4 to Table 12-6 Maximum/Minimum Permissible Baud Rate Error	(b)
CHAPTER 14 SERIAL INTERFACE IIC0		
p. 360	Partial change of condition in which STCEN bit is cleared in Figure 14-7 Format of IIC Flag Register 0 (IICF0)	(a)
p. 381	Addition of descriptions (1) Master operation in single master system, (2) Master operation in multimaster system, and (3) Slave operation to 14.5.16 Communication operations	(c)
p. 382	Partial change of Figure 14-23 Master Operation in Single-Master System	(c)
p. 387	Partial change of Figure 14-25 Slave Operation Flowchart (1)	(c)

Remark "Classification" in the above table classifies revisions as follows.

- (a): Error correction, (b): Addition/change of specifications, (c): Addition/change of description or note, (d): Addition/change of package, part number, or management division, (e): Addition/change of related documents

Page	Description	Classification
CHAPTER 16 STANDBY FUNCTION		
p. 441	Addition of oscillation accuracy stabilization time to and change of reset processing time in Figure 16-4 HALT Mode Release by Reset	(c)
p. 443	Addition of Note to and change of description of Serial interface IIC0 in Table 16-3 Operating Statuses in STOP Mode	(a), (c)
p. 444	Change of Caution 4 in 16.2.2 (1) STOP mode setting and operating statuses	(b), (c)
p. 444	Addition of oscillation accuracy stabilization time to and change of CPU clock supply stop time after STOP mode is released when AMPH = 1 in Figure 16-5 Operation Timing When STOP Mode Is Released	(b), (c)
p. 445	Addition of oscillation accuracy stabilization time to (2) When internal high-speed oscillation clock is used as CPU clock in Figure 16-6 STOP Mode Release by Interrupt Request Generation	(c)
p. 447	Addition of oscillation accuracy stabilization time to and change of reset processing time in Figure 16-7 STOP Mode Release by Reset	(c)
CHAPTER 17 RESET FUNCTION		
pp. 450, 451	Addition of oscillation accuracy stabilization time to Figures 17-2 Timing of Reset by RESET Input to 17-4 Timing of Reset in STOP Mode by RESET Input , change of reset processing time	(a)
CHAPTER 18 POWER-ON-CLEAR CIRCUIT		
pp. 457, 458	Partial change of description in 18.1 Functions of Power-on-Clear Circuit and 18.3 Operation of Power-on-Clear Circuit	(a)
p. 459	Change of voltage stabilization wait time and reset processing time in and addition of oscillation accuracy stabilization wait time, Notes 2 , and 3 to (1) In 1.59 V POC mode (option byte: POCMODE = 0) in Figure 18-2 Timing of Generation of Internal Reset Signal by Power-on-Clear Circuit and Low-Voltage Detector	(b), (c)
p. 460	Change of reset processing time in and addition of oscillation accuracy stabilization wait time and Caution 2 to (2) In 2.7 V/1.59 V POC mode (option byte: POCMODE = 1) in Figure 18-2 Timing of Generation of Internal Reset Signal by Power-on-Clear Circuit and Low-Voltage Detector	(b), (c)
CHAPTER 19 LOW-VOLTAGE DETECTOR		
p. 463	Change and addition of description in 19.1 Functions of Low-Voltage Detector	(a), (c)
p. 465	Change of description of LVIMD bit in Figure 19-2 Format of Low-Voltage Detection Register (LVIM)	(a)
p. 467	Change and addition of description in 19.4 Operation of Low-Voltage Detector	(a), (c)
pp. 473, 476	Change of description in 19.4.2 When used as interrupt	(a), (c)
pp. 474, 475, 477	Change of Figure 19-7 Timing of Low-Voltage Detector Interrupt Signal Generation (Detects Level of Supply Voltage (V_{DD})) and Figure 19-8 Timing of Low-Voltage Detector Interrupt Signal Generation (Detects Level of Input Voltage from External Input Pin (EXLVI))	(a)
p. 478	Change of description in (2) When used as interrupt in 19.5 Cautions for Low-Voltage Detector	(a), (c)

Remark "Classification" in the above table classifies revisions as follows.

- (a): Error correction, (b): Addition/change of specifications, (c): Addition/change of description or note, (d): Addition/change of package, part number, or management division, (e): Addition/change of related documents

Page	Description	Classification
CHAPTER 20 OPTION BYTE		
p. 481	Addition of Caution to (1) 0080H/1080H and (2) 0081H/1081H in 20.1 Functions of Option Bytes	(c)
CHAPTER 21 FLASH MEMORY		
p. 487	Change of Note 2 in Table 21-2 Wiring Between 78K0/KB2 (30-pin Plastic SSOP (MC-5A4 and MC-CAB Types)) and Dedicated Flash Memory Programmer	(c)
p. 489	Addition of Note to Figure 21-3 Example of Wiring Adapter for Flash Memory Writing in UART (UART6) Mode (30-pin Plastic SSOP (MC-5A4 and MC-CAB Types))	(c)
p. 491	Addition of Note 2 to Figure 21-6 Communication with Dedicated Flash Memory Programmer (UART6)	(c)
p. 491	Addition of Note 2 in Table 21-3 Pin Connection	(c)
p. 492	Change of Figure 21-7 FLMD0 Pin Connection Example and change of description	(a)
pp. 494, 495	Addition of Caution 3 , and Note to 21.5.6 Other signal pins	(c)
p. 495	Addition of description to 21.5.7 Power supply	(c)
p. 497	Change of Table 21-6 Communication Modes	(a)
p. 498	Change of Table 21-7 Flash Memory Control Commands	(c)
p. 499	Partial change of description in and addition of description to 21.7 Security Settings	(a), (c)
p. 500	Change of Table 21-9 Relationship Between Enabling Security Function and Command	(a), (c)
p. 500	Change of Table 21-10 Setting Security in Each Programming Mode	(a), (c)
p. 501	Addition of 21.8 Processing Time for Each Command When PG-FP4 Is Used (Reference)	(c)
p. 502	Deletion of Caution 4 from 21.9 Flash Memory Programming by Self-Programming	(c)
p. 503	Change of Figure 21-14 Flow of Self Programming (Rewriting Flash Memory)	(c)
pp. 504 to 507	Addition of Table 21-12 Processing Time and Interrupt Response Time for Self Programming Sample Library	(c)
p. 508	Partial change of boot start position in Figure 21-15 Boot Swap Function	(a)
CHAPTER 22 ON-CHIP DEBUG FUNCTION (μPD78F0503D ONLY)		
pp. 510, 511	Addition of recommended resistance to Note of Figure 22-1 Connection Example of QB-78K0MINI and μPD78F0503D (When OCD0A/X1 and OCD0B/X2 Are Used) and Figure 22-2 Connection Example of QB-78K0MINI and μPD78F0503D (When OCD1A/P31 and OCD1B/P32 Are Used)	(c)
p. 511	Addition of Figure 22-3 Connection of FLMD0 Pin for Self Programming or On-Chip Debugging	(c)
CHAPTER 24 ELECTRICAL SPECIFICATIONS (STANDARD PRODUCTS)		
pp. 526, 527	Change of following items of Absolute Maximum Ratings <ul style="list-style-type: none"> • Output current, high (addition of values of P20 to P23 and P121, P122) • Output current, low (addition of values of P20 to P23 and P121, P122) 	(b)
p. 528	Addition of value when RSTS = 0 to 8 MHz internal oscillator in Internal Oscillator Characteristics	(b)
p. 528	Change of MIN. value in condition where $1.8\text{ V} \leq V_{DD} < 2.7\text{ V}$ of internal low-speed oscillation clock frequency (f_{RL}) in Internal Oscillator Characteristics	(b)
p. 529	Addition of recommended oscillator for X1 oscillation	(c)

Remark "Classification" in the above table classifies revisions as follows.

- (a): Error correction, (b): Addition/change of specifications, (c): Addition/change of description or note, (d): Addition/change of package, part number, or management division, (e): Addition/change of related documents

Page	Description	Classification
pp. 532 to 535	Change of following items of DC Characteristics <ul style="list-style-type: none"> • Input voltage, high (change of values of P60, P61) • Input voltage, low (change of values of P60, P61) • Output voltage, low (addition of values in this condition: P60, P61, $2.7\text{ V} \leq V_{DD} < 4.0\text{ V}$, $I_{OL1} = 5.0\text{ mA}$) • Supply current (change of values when square wave is input in operation mode and HALT mode, and addition of values for oscillator connection). Addition of values where $T_A = -40$ to $+70^\circ\text{C}$ in STOP mode. Addition of Note 2. Change of Notes 1 and 4 • A/D converter operating current (addition of values while converter is not operating (when comparator operates). Addition of Note 6) • LVI operating current (change of MAX. value) 	(b)
p. 533	Addition of following item of DC Characteristics <ul style="list-style-type: none"> • External clock input voltage 	(b)
pp. 536, 539	Change of following items of AC Characteristics <ul style="list-style-type: none"> • T1000, T1010 input high-level width, low-level width (addition of values in condition where $1.8\text{ V} \leq V_{DD} < 2.7\text{ V}$) in (1) Basic operation • Transfer rate (change of values) in (2) Serial interface (a) UART6 and (b) UART0 	(b)
p. 543	Addition of MIN. and MAX. values as detection voltages of external input pin in LVI Circuit Characteristics	(b)
p. 544	Addition of Note 1 and value of write time to Basic Characteristics of Flash Memory Programming Characteristics . Deletion of “ (2) Serial write operation characteristics ” of old edition, and introduction of other manual	(b), (c)
CHAPTER 25 ELECTRICAL SPECIFICATIONS ((A) GRADE PRODUCTS, TARGET)		
p. 545	Addition of chapter	(c)
CHAPTER 26 PACKAGE DRAWINGS		
p. 565	Addition of the package drawings of (A) grade products	(c)
CHAPTER 27 RECOMMENDED SOLDERING CONDITIONS		
p. 567	Addition of chapter	(c)
APPENDIX A DEVELOPMENT TOOLS		
p. 574	Addition of FP-LITE3, FA-78F0503MC-5A4-MX and Remark 2 to A.4 Flash Memory Writing Tools	(d)
APPENDIX D LIST OF CAUTIONS		
p. 589	Addition of chapter	(c)
APPENDIX E REVISION HISTORY		
p. 619	Addition of E.2 Revision History of Preceding Editions	(c)

Remark “Classification” in the above table classifies revisions as follows.

- (a): Error correction, (b): Addition/change of specifications, (c): Addition/change of description or note,
- (d): Addition/change of package, part number, or management division, (e): Addition/change of related documents

<R>

E.2 Revision History of Preceding Editions

Here is the revision history of the preceding editions. Chapter indicates the chapter of each edition.

(1/6)

Edition	Description	Chapter
2nd	Addition of Note on a product with on-chip debug function to and modification of operating ambient temperature in 1.1 Features	CHAPTER 1 OUTLINE
	Addition of special grade products supporting automotive equipment to 1.2 Applications	
	Modification of 1.3 Ordering Information	
	Modification and addition of the following contents in 1.4 Pin Configuration (Top View) <ul style="list-style-type: none"> • Addition of note to and modification of caution 1 in 30-pin plastic SSOP (7.62 mm (300)) • Addition of 36-pin plastic FLGA (4x4) • Addition of Note to Pin Identification 	
	Modification of the following items on the function list in 1.5 78K0/Kx2 Series Lineup <ul style="list-style-type: none"> • Supply voltage range of internal low-speed oscillation clock • Detection voltage of POC • Operating ambient temperature 	
	Addition of pin to “On-chip debug” in 1.6 Block Diagram	
	Modification and addition of the following contents in 1.7 Outline of Functions <ul style="list-style-type: none"> • Modification of oscillation frequency range of high-speed system clock • Modification of supply voltage range of internal low-speed oscillation clock • Addition of operating ambient temperature of (T2) product • Addition of the package 	
	Modification of outline of timer in 1.7 Outline of Functions	
	Modification of Table 2-1 Pin I/O Buffer Power Supplies	
	Addition of Note to (1) Port functions (1/2) to (2) Non-port functions (1/2) in 2.1 Pin Function List	
	Addition of Notes 1 and 2 to (2) Non-port functions (2/2) in 2.1 Pin Function List	
	Addition of Note to 2.2.10 REGC	
	Addition of description of EV_{DD} in 2.2.11 V_{DD} and EV_{DD}	
	Addition of description of EV_{SS} in 2.2.12 V_{SS} and EV_{SS}	
	Addition of Note 3 and Remark to Table 2-2 Pin I/O Circuit Types	
	Addition of Remark to Figure 2-1 Pin I/O Circuit List	
	Modification of Table 3-1 Set Values of Internal Memory Size Switching Register (IMS)	CHAPTER 3 CPU ARCHITECTURE
	Modification of Figure 3-1 Memory Map (μPD78F0500) to Figure 3-5 Memory Map (μPD78F0503D)	
	Modification of description in (3) Option byte area and (5) On-chip debug security ID setting area (μPD78F0503D only) in 3.1.1	
	Modification of [Description example] in 3.4.4 Short direct addressing	CHAPTER 4 PORT FUNCTIONS
	Modification of Table 4-1 Pin I/O Buffer Power Supplies	
	Addition of Remark to the following figures <ul style="list-style-type: none"> • Figure 4-2 Block Diagram of P00 • Figure 4-3 Block Diagram of P01 • Figure 4-4 Block Diagram of P10 • Figure 4-5 Block Diagram of P11 and P14 • Figure 4-6 Block Diagram of P12 and P15 • Figure 4-7 Block Diagram of P13 • Figure 4-8 Block Diagram of P16 and P17 • Figure 4-10 Block Diagram of P30 to P32 • Figure 4-11 Block Diagram of P33 • Figure 4-13 Block Diagram of P120 	
	Addition of Caution to 4.2.2 Port 1	
	Addition of description to 4.2.3 Port 2 and addition of Table 4-3 Setting Functions of P20/ANI0 to P23/ANI3 Pins	

Edition	Description	Chapter
2nd	Addition of Remark to and modification of Caution in 4.2.6 Port 12 Modification of Figure 4-13 Block Diagram of P120 Modification of Figure 4-14 Block Diagram of P121 and P122 Addition of (4) A/D port configuration register (ADPC) to 4.3 Registers Controlling Port Function Addition of Remark 2 and Notes 1 and 2 to Table 4-4 Settings of Port Mode Register and Output Latch When Using Alternate Function (2/2)	CHAPTER 4 PORT FUNCTIONS
	Modification of oscillation frequency range X1 oscillator and external main system clock in 5.1 (1) Main system clock , and addition to description in 5.1 (3) Internal low-speed oscillation clock Modification of description in 5.3 (7) Oscillation stabilization time select register (OSTS) Modification of oscillation frequency range in 5.4.1 X1 oscillator Addition of Figure 5-11 Clock Generator Operation When Power Supply Voltage Is Turned On (When 1.59 V POC Mode Is Set (Option Byte: POCMODE = 0)) Addition of Figure 5-12 Clock Generator Operation When Power Supply Voltage Is Turned On (When 2.7 V/1.59 V POC Mode Is Set (Option Byte: POCMODE = 1)) Modification of 5.6.1 Controlling high-speed system clock Modification of 5.6.2 Example of controlling internal high-speed oscillation clock Modification of description in Table 5-3 Clocks Supplied to CPU and Peripheral Hardware, and Register Setting Addition of Remark to Figure 5-13 CPU Clock Status Transition Diagram (When 1.59 V POC Mode Is Set (Option Byte: POCMODE = 0)) Modification of description of (3) CPU clock changing from internal high-speed oscillation clock (B) to high-speed system clock (C) in Table 5-4 CPU Clock Transition and SFR Register Setting Examples Modification of Table 5-5 Changing CPU Clock Addition of 5.6.7 Time required for switchover main system clock Addition of 5.6.8 Conditions before clock oscillation is stopped Addition of 5.6.9 Peripheral Hardware and Source Clocks	CHAPTER 5 CLOCK GENERATOR
	Revision of chapter	CHAPTER 6 16-BIT TIMER/EVENT COUNTERS 00
	Modification of description in 7.2 (2) 8-bit timer compare register 5n (CR5n)	CHAPTER 7 8-BIT TIMER/EVENT COUNTERS 50 AND 51
	Modification of Figure 8-2 Block Diagram of 8-Bit Timer H1 Modification of description in (1) 8-bit timer H compare register 0n (CMP0n) and (2) 8-bit timer H compare register 1n (CMP1n) in 8.2 Modification of Figure 8-6 Format of 8-Bit Timer H Mode Register 1 (TMHMD1) Modification of Figure 8-12 (e) Operation by changing CMP1n (CMP1n = 02H → 03H, CMP0n = A5H) Modification of description in 8.4.3 Carrier generator operation (8-bit timer H1 only) Addition of <3> to Figure 8-13 Transfer Timing Addition of <8> to Setting in 8.4.3	CHAPTER 8 8-BIT TIMERS H0 AND H1

Edition	Description	Chapter	
2nd	Modification of (a) Operation when CMP01 = N, CMP11 = N and (b) Operation when CMP01 = N, CMP11 = M in Figure 8-15	CHAPTER 8 8-BIT TIMERS H0 AND H1	
	Modification of description in Figure 8-15 (c) Operation when CMP11 is changed		
	Modification of description in 9.1 Functions of Watchdog Timer	CHAPTER 9 WATCHDOG TIMER	
	Addition to description in and addition of Caution 4 to 9.4.1 Controlling operation of watchdog timer		
	Modification of the following items in 10.2 Configuration of A/D Converter (2) Sample & hold circuit (3) Series resistor string (5) Successive approximation register (SAR) (9) AV_{REF} pin	CHAPTER 10 A/D CONVERTER	
	Addition to Caution 1 in and addition of Caution 4 to Table 10-2 A/D Conversion Time Selection		
	Modification of Cautions 2 and 3 in Figure 10-8 Format of Analog Input Channel Specification Register (ADS)		
	Modification of description in 10.3 (5) A/D port configuration register (ADPC)		
	Modification of Cautions 2 and 3 in Figure 10-9 Format of A/D Port Configuration Register (ADPC)		
	Modification of Table 10-3 Setting Functions of ANI0/P20 to ANI3/P23 Pins		
	Modification of 10.4.1 Basic operations of A/D converter		
	Modification of description in Figure 10-11 Basic Operation of A/D Converter		
	Modification of expression in 10.4.2 Input voltage and conversion results		
	Modification of description in 10.4.3 A/D converter operation mode		
	Modification of the description of the following items in 10.6 Cautions for A/D Converter (1) Operating current in STOP mode (4) Noise countermeasures (6) Input impedance of ANI0 to ANI7 pins (11) Internal equivalent circuit		
	Addition of maximum transfer rate and Caution 4 to 11.1 (2) Asynchronous serial interface (UART) mode		CHAPTER 11 SERIAL INTERFACE UART0
	Addition of Caution 1 to 11.2 (3) Transmit shift register 0 (TXS0)		
	Addition of Caution 5 to Figure 11-2 Format of Asynchronous Serial Interface Operation Mode Register 0 (ASIM0)		
	Modification of description in 11.3 (2) Asynchronous serial interface reception error status register 0 (ASIS0)		
	Modification of Caution 1 in Figure 11-9 Reception Completion Interrupt Request Timing		
	Addition of Table 11-4 Set Value of TPS01 and TPS00		
	Addition of maximum transfer rate and Cautions 4 and 5 to 12.1 (2) Asynchronous serial interface (UART) mode	CHAPTER 12 SERIAL INTERFACE UART6	
	Modification of Figure 12-1 LIN Transmission Operation		
	Modification of Figure 12-2 LIN Reception Operation		
	Addition of Caution 3 to 12.2 (3) Transmit buffer register 6 (TXB6)		
	Addition of Cautions 4 and 5 to Figure 12-5 Format of Asynchronous Serial Interface Operation Mode Register 6 (ASIM6)		

Edition	Description	Chapter
2nd	Modification of description in 12.3 (2) Asynchronous serial interface reception error status register 6 (ASIS6)	CHAPTER 12 SERIAL INTERFACE UART6
	Addition of Caution 6 to Figure 12-10 Format of Asynchronous Serial Interface Control Register 6 (ASICL6)	
	Modification of description in 12.3 (7) Input switch control register (ISC)	
	Modification of Caution 1 in 12.4.2 (2) (e) Normal reception	
	Modification of Figure 13-1 Block Diagram of Serial Interface CSI10	CHAPTER 13 SERIAL INTERFACE CSI10
	Modification of Note 2 in Figure 13-2 Format of Serial Operation Mode Register 10 (CSIM10)	
	Modification of Caution 2 in Figure 13-3 Format of Serial Clock Selection Register 10 (CSIC10)	
	Modification of Note 1 of CSIM10 and CSIM11 in 13.4.1 (1) Register used	
	Addition of (b) Type 3: CKP10 = 1, DAP10 = 0 and (d) Type 4: CKP1n = 1, DAP1n = 1 to Figure 13-7 Output Operation of First Bit	
	Addition of (b) Type 3: CKP10 = 1, DAP10 = 0 and (d) Type 4: CKP10 = 1, DAP10 = 1 in Figure 13-8 Output Value of SO10 Pin (Last Bit)	
	Modification of Figure 14-1 Block Diagram of Serial Interface IIC0	CHAPTER 14 SERIAL INTERFACE IIC0
	Addition of Caution 2 to 14.2 (1) IIC shift register 0 (IIC0) and addition to description in (2) Slave address register 0 (SVA0)	
	Addition of 14.2 (13) Stop condition generator	
	Addition of description to IICE0 and addition of Caution to Figure 14-5 Format of IIC Control Register 0 (IICC0) (1/4)	
	Addition of Note 2 to Figure 14-5 Format of IIC Control Register 0 (IICC0) (2/4)	
	Addition of description to STT0 in Figure 14-5 Format of IIC Control Register 0 (IICC0) (3/4)	
	Addition of clearing condition to STCF and IICBSY in Figure 14-7 Format of IIC Flag Register 0 (IICF0)	
	Modification of description in 14.3 (4) IIC clock selection register 0 (IICCL0)	
	Modification of description in 14.3 (6) I²C transfer clock setting method	
	Modification of Table 14-2 Selection Clock Setting	
	Addition of cause that ACK is not returned to 14.5.4 Acknowledge (ACK)	
	Addition of 14.5.7 Canceling wait	
	Modification of Table 14-6 Wait Periods and Figure 14-20 Communication Reservation Timing	
	Modification of Table 14-7 Wait Periods	
	Addition of (4) to (6) to 14.5.15 Cautions	
	Modification of 14.5.16 (1) Master operation (single-master system) and (2) Master operation (multi-master system)	
	Modification of Figure 14-25 Slave Operation Flowchart (1) and Figure 14-26 Slave Operation Flowchart (2)	
	Addition of Note to (a) (i) When WTIMO = 0 to and modification of (ii) When WTIMO = 1 in 14.5.17 (1) Master device operation	
	Addition of Notes 1 to 3 to (b) (i) When WTIMO = 0 in 14.5.17 (1) Master device operation	
	Addition of Note to (c) (i) When WTIMO = 0 in 14.5.17 (1) Master device operation	

Edition	Description	Chapter
2nd	<p>Modification of the value of the following items of IICS0 register in 14.5.17</p> <p>(2) (d) (i) When WTIM0 = 0 (after restart, does not match with address (= not extension code))</p> <p>(2) (d) (ii) When WTIM0 = 1 (after restart, does not match with address (= not extension code))</p> <p>(3) (d) (i) When WTIM0 = 0 (after restart, does not match with address (= not extension code))</p> <p>(3) (d) (ii) When WTIM0 = 1 (after restart, does not match with address (= not extension code))</p> <p>(6) (d) (ii) Extension code</p> <p>(6) (e) When loss occurs due to stop condition during data transfer</p> <p>(6) (h) (ii) When WTIM0 = 1</p> <p>Addition of description to 14.5.17 (5) Arbitration loss operation (operation as slave after arbitration loss) and (6) Operation when arbitration loss occurs (no communication after arbitration loss)</p> <p>Addition of description when (i) When WTIM0 = 0 to the following items in 14.5.17 (6) Operation when arbitration loss occurs (no communication after arbitration loss)</p> <p>(f) When arbitration loss occurs due to low-level data when attempting to generate a restart condition</p> <p>(g) When arbitration loss occurs due to a stop condition when attempting to generate a restart condition</p> <p>(h) When arbitration loss occurs due to low-level data when attempting to generate a stop condition</p> <p>Modification of Figure 14-27 Example of Master to Slave Communication (When 9-Clock Wait Is Selected for Both Master and Slave) and Figure 14-28 Example of Slave to Master Communication (When 8-Clock Wait Is Selected for Master, 9-Clock Wait Is Selected for Slave)</p>	CHAPTER 14 SERIAL INTERFACE IIC0
	Modification of Caution 2 in 16.1.1 Standby function	CHAPTER 16 STANDBY FUNCTION
	Modification of description in 16.1.2 (2) Oscillation stabilization time select register (OSTS)	
	Modification of Figure 16-4 HALT Mode Release by Reset	
	Modification of Figure 16-5 Operation Timing When STOP Mode Is Released	
	Modification of Figure 16-7 STOP Mode Release by Reset	
	Modification of Figure 17-2 Timing of Reset by RESET Input	CHAPTER 17 RESET FUNCTION
	Modification of Figure 17-3 Timing of Reset Due to Watchdog Timer Overflow	
	Modification of Figure 17-4 Timing of Reset in STOP Mode by RESET Input	
	Modification of table in Note of Table 17-2 Hardware Statuses After Reset Acknowledgment (3/3)	
	Addition of description of 2.7 V/1.59 V POC mode to 18.1 Functions of Power-on-Clear Circuit	CHAPTER 18 POWER-ON-CLEAR CIRCUIT
	Modification of Figure 18-3 Example of Software Processing After Reset Release (1/2)	
	Modification of Figure 19-1 Block Diagram of Low-Voltage Detector	CHAPTER 19 LOW- VOLTAGE DETECTOR
	Modification of Figure 19-3 Format of Low-Voltage Detection Level Selection Register (LVIS)	
	Addition of (2) In 2.7 V/1.59 V POC mode (option byte: POCMODE = 1) to Figure 19-5 Timing of Low-Voltage Detector Internal Reset Signal Generation (Detects Level of Supply Voltage (V _{DD}))	
	Modification of (1) In 1.59 V POC mode (option byte: POCMODE = 0) in and addition of (2) In 2.7 V/1.59 V POC mode (option byte: POCMODE = 1) to Figure 19-7 Timing of Low-Voltage Detector Interrupt Signal Generation (Detects Level of Supply Voltage (V _{DD}))	

Edition	Description	Chapter
2nd	Modification of Figure 19-8 Timing of Low-Voltage Detector Interrupt Signal Generation (Detects Level of Input Voltage from External Input Pin (EXLVI))	CHAPTER 19 LOW-VOLTAGE DETECTOR
	Modification of Figure 19-9 Example of Software Processing After Reset Release (1/2)	
	Modification of description in 20.1 Functions of Option Bytes Modification of Note in and addition of setting of area 0081H/1081H to 0084H/1084H to Figure 20-1 Format of Option Byte	CHAPTER 20 OPTION BYTE
	Modification of description example of software for setting the option bytes	
	Modification of pin numbers in Table 21-2 Wiring Between 78K0/KB2 (30-pin Plastic SSOP (MC-5A4 Type)) and Dedicated Flash Programmer	CHAPTER 21 FLASH MEMORY
	Modification of Figure 21-2 Example of Wiring Adapter for Flash Memory Writing in 3-Wire Serial I/O (CSI10) Mode (30-pin Plastic SSOP (MC-5A4 Type))	
	Modification of Figure 21-3 Example of Wiring Adapter for Flash Memory Writing in UART (UART6) Mode (30-pin Plastic SSOP (MC-5A4 Type))	
	Modification of transfer rate in (1) CSI10 and (2) UART6 in 21.4	
	Modification of transfer rate in Speed column of Table 21-6 Communication Modes	
	Addition of 21.7 Security Settings	
	Modification of 21.8.1 Boot swap function	
	Revision of chapter	CHAPTER 22 ON-CHIP DEBUG FUNCTION (μPD78F0503D ONLY)
	Revision of chapter	CHAPTER 24 ELECTRICAL SPECIFICATIONS (TARGET)
	Addition of package drawing	CHAPTER 25 PACKAGE DRAWINGS
	Modification of <Conditions for maximum/minimum number of wait clocks> of A/D converter in Table 26-1 Registers That Generate Wait and Number of CPU Wait Clocks	CHAPTER 26 CAUTIONS FOR WAIT
	Addition of (2) When using the on-chip debug emulator QB-78K0MINI to Figure A-1 Development Tool Configuration	APPENDIX A DEVELOPMENT TOOLS
	Addition of FA-78F0503FC-AA3-MX to A.4 Flash Memory Writing Tools	
	Addition of QB-36FC-EA-01T, QB-36FC-NQ-01T, and QB-78K0KX2-T36FC to A.5.1 When using in-circuit emulator QB-78K0KX2	
	Addition of A.5.2 When using on-chip debug emulator QB-78K0MINI	
	Addition of chapter	APPENDIX B NOTES ON TARGET SYSTEM DESIGN
	Addition of chapter	APPENDIX D REVISION HISTORY

[MEMO]

*For further information,
please contact:*

NEC Electronics Corporation
1753, Shimonumabe, Nakahara-ku,
Kawasaki, Kanagawa 211-8668,
Japan
Tel: 044-435-5111
<http://www.necel.com/>

[America]

NEC Electronics America, Inc.
2880 Scott Blvd.
Santa Clara, CA 95050-2554, U.S.A.
Tel: 408-588-6000
800-366-9782
<http://www.am.necel.com/>

[Europe]

NEC Electronics (Europe) GmbH
Arcadiastrasse 10
40472 Düsseldorf, Germany
Tel: 0211-65030
<http://www.eu.necel.com/>

Hanover Office
Podbielski Strasse 166 B
30177 Hanover
Tel: 0 511 33 40 2-0

Munich Office
Werner-Eckert-Strasse 9
81829 München
Tel: 0 89 92 10 03-0

Stuttgart Office
Industriestrasse 3
70565 Stuttgart
Tel: 0 711 99 01 0-0

United Kingdom Branch
Cygnus House, Sunrise Parkway
Linford Wood, Milton Keynes
MK14 6NP, U.K.
Tel: 01908-691-133

Succursale Française
9, rue Paul Dautier, B.P. 52180
78142 Velizy-Villacoublay Cédex
France
Tel: 01-3067-5800

Sucursal en España
Juan Esplandiú, 15
28007 Madrid, Spain
Tel: 091-504-2787

Tyskland Filial
Täby Centrum
Entrance S (7th floor)
18322 Täby, Sweden
Tel: 08 638 72 00

Filiale Italiana
Via Fabio Filzi, 25/A
20124 Milano, Italy
Tel: 02-667541

Branch The Netherlands
Limburglaan 5
5616 HR Eindhoven
The Netherlands
Tel: 040 265 40 10

[Asia & Oceania]

NEC Electronics (China) Co., Ltd
7th Floor, Quantum Plaza, No. 27 ZhiChunLu Haidian
District, Beijing 100083, P.R.China
TEL: 010-8235-1155
<http://www.cn.necel.com/>

NEC Electronics Shanghai Ltd.
Room 2509-2510, Bank of China Tower,
200 Yincheng Road Central,
Pudong New Area, Shanghai P.R. China P.C:200120
Tel: 021-5888-5400
<http://www.cn.necel.com/>

NEC Electronics Hong Kong Ltd.
12/F., Cityplaza 4,
12 Taikoo Wan Road, Hong Kong
Tel: 2886-9318
<http://www.hk.necel.com/>

Seoul Branch
11F., Samik Lavied'or Bldg., 720-2,
Yeoksam-Dong, Kangnam-Ku,
Seoul, 135-080, Korea
Tel: 02-558-3737

NEC Electronics Taiwan Ltd.
7F, No. 363 Fu Shing North Road
Taipei, Taiwan, R. O. C.
Tel: 02-2719-2377

NEC Electronics Singapore Pte. Ltd.
238A Thomson Road,
#12-08 Novena Square,
Singapore 307684
Tel: 6253-8311
<http://www.sg.necel.com/>