

The RF Line  
**NPN Silicon**  
**RF Power Transistor**

... designed primarily for wideband large-signal output amplifier stages in the 100 to 500 MHz frequency range.

- Guaranteed Performance @ 400 MHz, 28 Vdc  
Output Power = 80 Watts over 225 to 400 MHz Band  
Minimum Gain = 7.3 dB @ 400 MHz
- Built-In Matching Network for Broadband Operation Using Double Match Technique
- 100% Tested for Load Mismatch at all Phase Angles with 30:1 VSWR
- Gold Metallization System for High Reliability Applications
- Characterized for 100 to 500 MHz

**MAXIMUM RATINGS**

Rating	Symbol	Value	Unit
Collector-Emitter Voltage	$V_{CEO}$	33	Vdc
Collector-Base Voltage	$V_{CBO}$	60	Vdc
Emitter-Base Voltage	$V_{EBO}$	4.0	Vdc
Collector Current — Continuous	$I_C$	9.0	Adc
— Peak		12	
Total Device Dissipation @ $T_C = 25^\circ\text{C}$ (1)	$P_D$	250	Watts
Derate above $25^\circ\text{C}$		1.43	W/ $^\circ\text{C}$
Storage Temperature Range	$T_{stg}$	-65 to +150	$^\circ\text{C}$

**THERMAL CHARACTERISTICS**

Characteristic	Symbol	Max	Unit
Thermal Resistance, Junction to Case	$R_{\theta JC}$	0.7	$^\circ\text{C/W}$

**ELECTRICAL CHARACTERISTICS** ( $T_C = 25^\circ\text{C}$  unless otherwise noted.)

Characteristic	Symbol	Min	Typ	Max	Unit
----------------	--------	-----	-----	-----	------

**OFF CHARACTERISTICS**

Collector-Emitter Breakdown Voltage ( $I_C = 80\text{ mAdc}$ , $I_B = 0$ )	$V_{(BR)CEO}$	33	—	—	Vdc
Collector-Emitter Breakdown Voltage ( $I_C = 80\text{ mAdc}$ , $V_{BE} = 0$ )	$V_{(BR)CES}$	60	—	—	Vdc
Emitter-Base Breakdown Voltage ( $I_E = 8.0\text{ mAdc}$ , $I_C = 0$ )	$V_{(BR)EBO}$	4.0	—	—	Vdc
Collector-Base Breakdown Voltage ( $I_C = 80\text{ mAdc}$ , $I_C = 0$ )	$V_{(BR)CBO}$	60	—	—	Vdc
Collector Cutoff Current ( $V_{CB} = 30\text{ Vdc}$ , $I_E = 0$ )	$I_{CBO}$	—	—	5.0	mAdc

**ON CHARACTERISTICS**

DC Current Gain ( $I_C = 4.0\text{ Adc}$ , $V_{CE} = 5.0\text{ Vdc}$ )	$h_{FE}$	20	—	80	—
--	----------	----	---	----	---

**DYNAMIC CHARACTERISTICS**

Output Capacitance ( $V_{CB} = 28\text{ Vdc}$ , $I_E = 0$ , $f = 1.0\text{ MHz}$ )	$C_{ob}$	—	95	125	pF
---	----------	---	----	-----	----

NOTE:

1. This device is designed for RF operation. The total device dissipation rating applies only when the device is operated as an RF amplifier.

**MRF327**

**80 W, 100 to 500 MHz**  
**CONTROLLED "Q"**  
**BROADBAND RF POWER**  
**TRANSISTOR**  
**NPN SILICON**

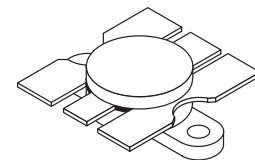

**CASE 316-01, STYLE 1**

NOT RECOMMENDED FOR NEW DESIGN

NOT RECOMMENDED FOR NEW DESIGN

**ELECTRICAL CHARACTERISTICS – continued** ( $T_C = 25^\circ\text{C}$  unless otherwise noted.)

Characteristic	Symbol	Min	Typ	Max	Unit
<b>FUNCTIONAL TESTS</b> (Figure 1)					
Common-Emitter Amplifier Power Gain ( $V_{CC} = 28\text{ Vdc}$ , $P_{Out} = 80\text{ W}$ , $f = 400\text{ MHz}$ )	$G_{PE}$	7.3	9.0	—	dB
Collector Efficiency ( $V_{CC} = 28\text{ Vdc}$ , $P_{Out} = 80\text{ W}$ , $f = 400\text{ MHz}$ )	$\eta$	50	60	—	%
Load Mismatch ( $V_{CC} = 28\text{ Vdc}$ , $P_{Out} = 80\text{ W}$ , $f = 400\text{ MHz}$ , $VSWR = 30:1$ All Phase Angles)	$\psi$	No Degradation in Output Power			

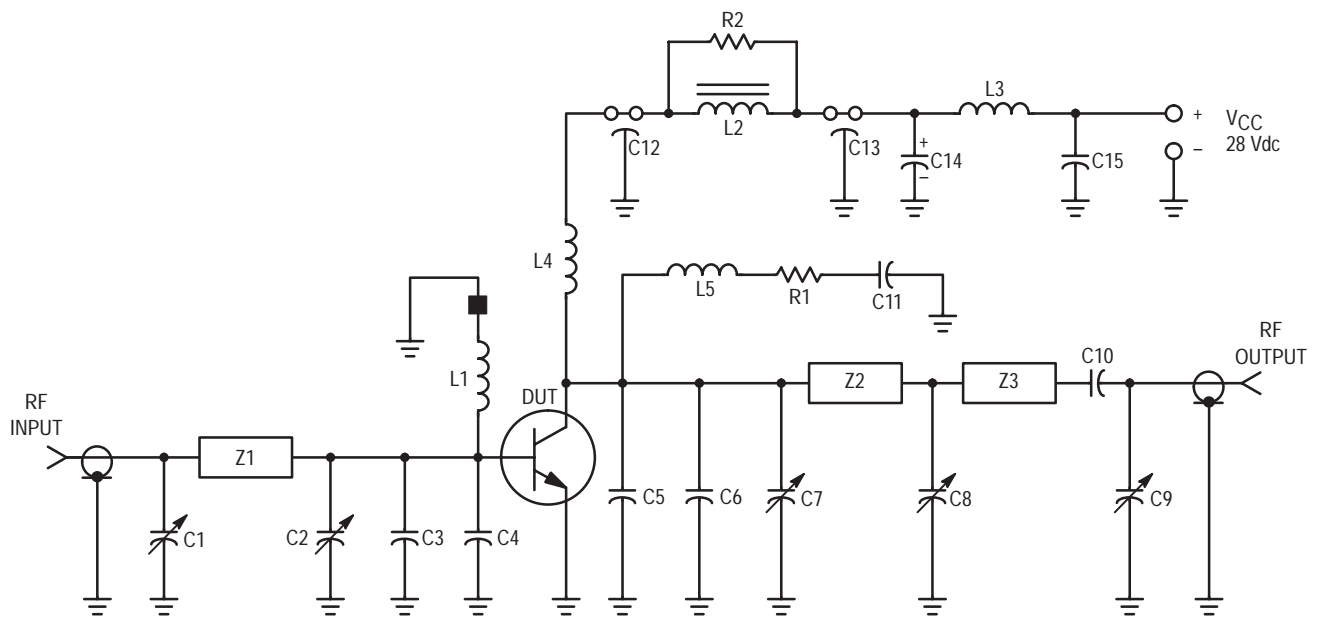

C1, C2, C7, C8, C9 — 1.0–20 pF Piston Trimmer (Johanson JMC 5501)

C3, C4 — 36 pF ATC 100 mil Chip Capacitor

C5, C6 — 43 pF ATC 100 mil Chip Capacitor

C10 — 100 pF UNELCO

C11, C15 — 0.1  $\mu\text{F}$  Erie Redcap

C12, C13 — 680 pF Feedthru

C14 — 1.0  $\mu\text{F}$  50 V Tantalum

L1 — 4 Turns #22 AWG Enameled, 3/16" ID Closewound with Ferroxcube Bead (#56–590–65/4B) on Ground End of Coil

L2 — Ferroxcube VK200–19/4B Ferrite Choke

L3 — 7 Turns #18 AWG, 11/16" Long, Wound on a 100 k $\Omega$  2.0 Watt

L4 — 6 Turns #20 AWG Enameled, 3/16" ID Closewound

L5 — 4 Turns #22 AWG Enameled, 1/8" ID Closewound

Z1 — Microstrip 0.2" W x 1.5" L

Z2 — Microstrip 0.17" W x 1.16" L

Z3 — Microstrip 0.17" W x 0.63" L

R1, R2 — 10  $\Omega$  2.0 Watt

Board — Glass Teflon  $\epsilon_r = 2.56$ ,  $t = 0.062"$

Input/Output Connectors Type N

DUT Socket Lead Frame Etched from 80–mil–Thick Copper

**Figure 1. 400 MHz Test Circuit**

NOT RECOMMENDED FOR NEW DESIGN

NOT RECOMMENDED FOR NEW DESIGN

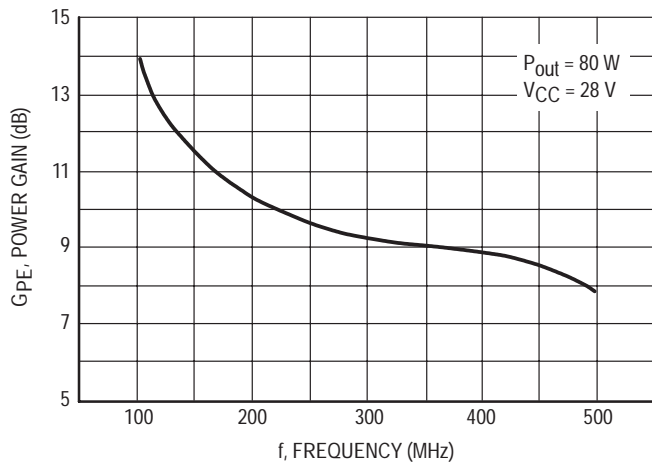

Figure 2. Power Gain versus Frequency

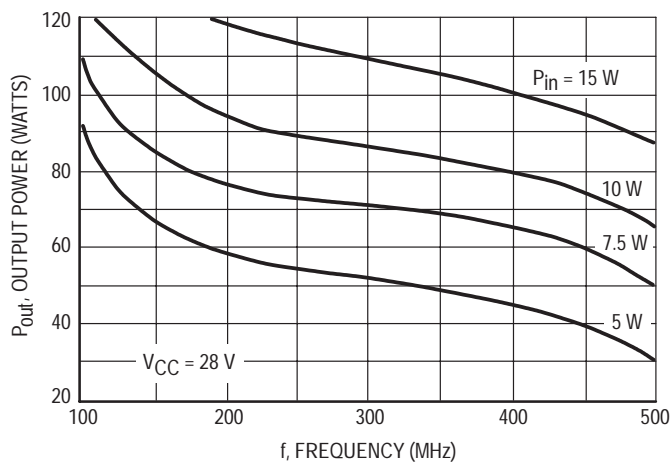

Figure 3. Output Power versus Frequency

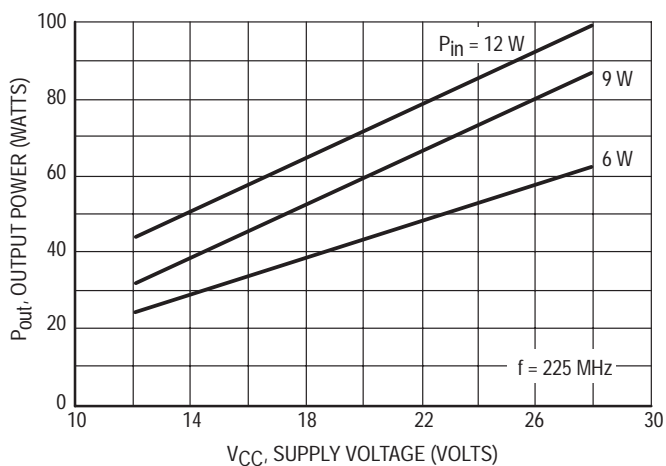

Figure 4. Output Power versus Supply Voltage

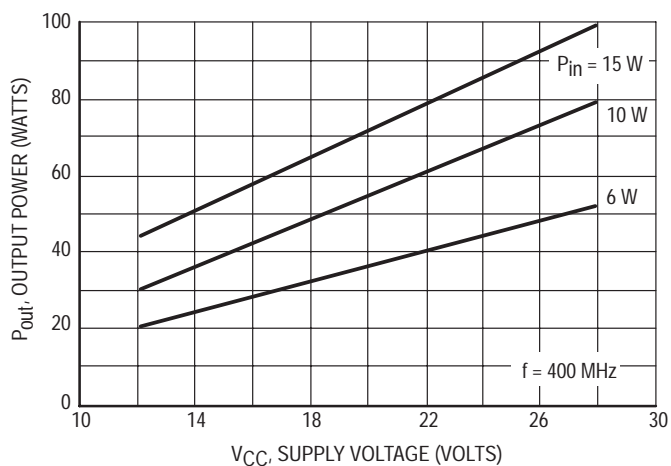

Figure 5. Output Power versus Supply Voltage

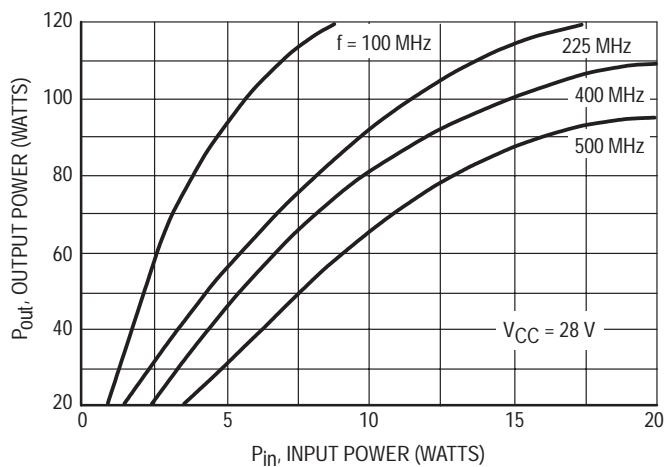

Figure 6. Output Power versus Input Power

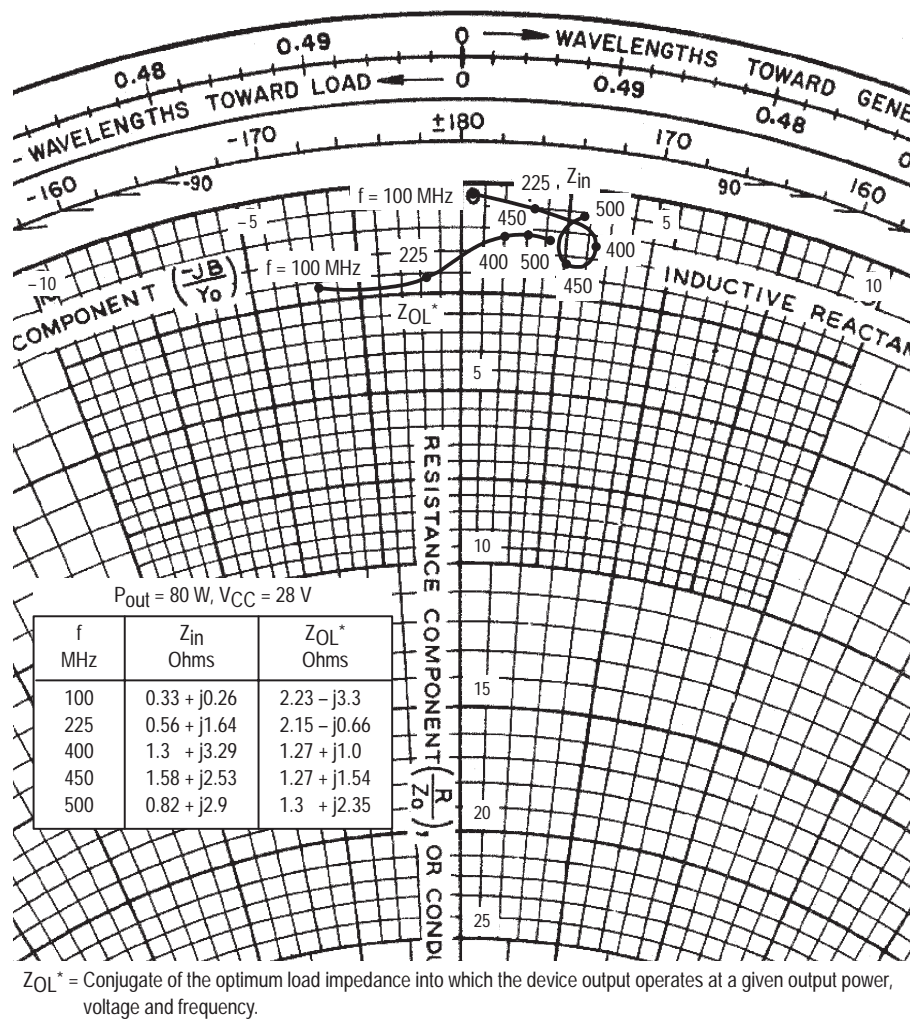
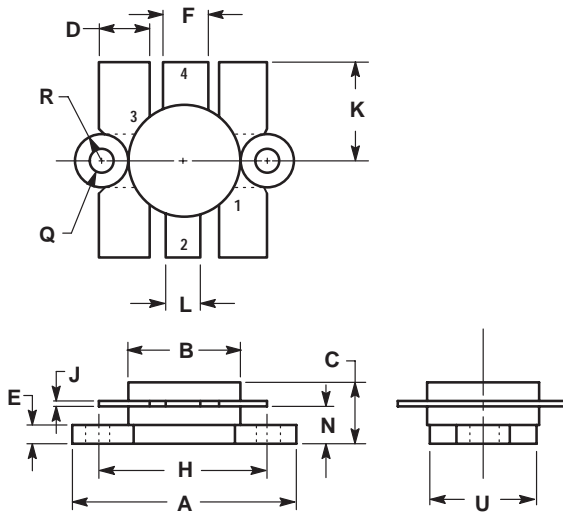

Figure 7. Series Equivalent Input-Output Impedance

# PACKAGE DIMENSIONS

NOT RECOMMENDED FOR NEW DESIGN

NOT RECOMMENDED FOR NEW DESIGN



NOTES:  
1. FLANGE IS ISOLATED IN ALL STYLES.

DIM	INCHES		MILLIMETERS	
	MIN	MAX	MIN	MAX
A	24.38	25.14	0.960	0.990
B	12.45	12.95	0.490	0.510
C	5.97	7.62	0.235	0.300
D	5.33	5.58	0.210	0.220
E	2.16	3.04	0.085	0.120
F	5.08	5.33	0.200	0.210
H	18.29	18.54	0.720	0.730
J	0.10	0.15	0.004	0.006
K	10.29	11.17	0.405	0.440
L	3.81	4.06	0.150	0.160
N	3.81	4.31	0.150	0.170
Q	2.92	3.30	0.115	0.130
R	3.05	3.30	0.120	0.130
U	11.94	12.57	0.470	0.495

STYLE 1:  
PIN 1. EMITTER  
2. COLLECTOR  
3. EMITTER  
4. BASE

**CASE 316-01  
ISSUE D**

NOT RECOMMENDED FOR NEW DESIGN

NOTES

NOT RECOMMENDED FOR NEW DESIGN

NOT RECOMMENDED FOR NEW DESIGN

NOTES

NOT RECOMMENDED FOR NEW DESIGN

NOT RECOMMENDED FOR NEW DESIGN

Motorola reserves the right to make changes without further notice to any products herein. Motorola makes no warranty, representation or guarantee regarding the suitability of its products for any particular purpose, nor does Motorola assume any liability arising out of the application or use of any product or circuit, and specifically disclaims any and all liability, including without limitation consequential or incidental damages. "Typical" parameters which may be provided in Motorola data sheets and/or specifications can and do vary in different applications and actual performance may vary over time. All operating parameters, including "typicals" must be validated for each customer application by customer's technical experts. Motorola does not convey any license under its patent rights nor the rights of others. Motorola products are not designed, intended, or authorized for use as components in systems intended for surgical implant into the body, or other applications intended to support or sustain life, or for any other application in which the failure of the Motorola product could create a situation where personal injury or death may occur. Should Buyer purchase or use Motorola products for any such unintended or unauthorized application, Buyer shall indemnify and hold Motorola and its officers, employees, subsidiaries, affiliates, and distributors harmless against all claims, costs, damages, and expenses, and reasonable attorney fees arising out of, directly or indirectly, any claim of personal injury or death associated with such unintended or unauthorized use, even if such claim alleges that Motorola was negligent regarding the design or manufacture of the part. Motorola and  are registered trademarks of Motorola, Inc. Motorola, Inc. is an Equal Opportunity/Affirmative Action Employer.

Mfax is a trademark of Motorola, Inc.

**How to reach us:**

**USA/EUROPE/Locations Not Listed:** Motorola Literature Distribution,  
P.O. Box 5405, Denver, Colorado 80217. 1-303-675-2140 or 1-800-441-2447

**JAPAN:** Motorola Japan Ltd.; SPS, Technical Information Center,  
3-20-1, Minami-Azabu, Minato-ku, Tokyo 106-8573 Japan.  
81-3-3440-3569

**Customer Focus Center: 1-800-521-6274**

**Mfax™:** RMFAXO@email.sps.mot.com – TOUCHSTONE 1-602-244-6609  
Motorola Fax Back System – US & Canada ONLY 1-800-774-1848

**ASIA/PACIFIC:** Motorola Semiconductors H.K. Ltd.; Silicon Harbour Centre,  
2, Dai King Street, Tai Po Industrial Estate, Tai Po, N.T., Hong Kong.  
852-2668334

**HOME PAGE:** <http://motorola.com/spc/>  
– <http://sps.motorola.com/mfax/>



**MOTOROLA**



**MRF327/D**

NOT RECOMMENDED FOR NEW DESIGN