

The RF Line
NPN Silicon
RF Power Transistor

... designed primarily for wideband large-signal output amplifier stages in the 225 to 400 MHz frequency range.

- Guaranteed Performance in 225 to 400 MHz Broadband Amplifier @ 28 Vdc
Output Power = 60 Watts over 225 to 400 MHz Band
Minimum Gain = 7.8 dB @ 400 MHz
- Built-In Matching Network for Broadband Operation Using Double Match Technique
- 100% Tested for Load Mismatch at all Phase Angles with 30:1 VSWR
- Gold Metallization System for High Reliability Applications

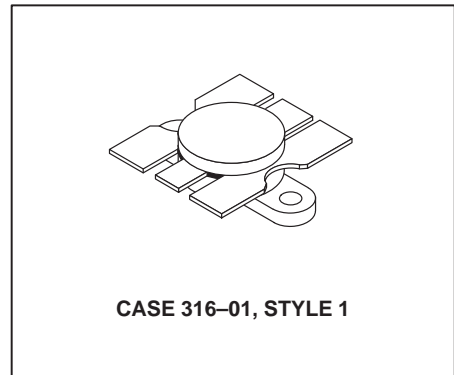
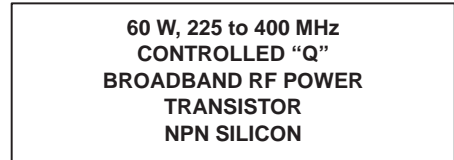

LIFETIME BUY

LAST SHIP 06/07/00
LAST ORDER 06/01/00

MAXIMUM RATINGS*

Rating	Symbol	Value	Unit
Collector-Emitter Voltage	V_{CEO}	33	Vdc
Collector-Base Voltage	V_{CBO}	60	Vdc
Emitter-Base Voltage	V_{EBO}	4.0	Vdc
Total Device Dissipation @ $T_C = 25^\circ\text{C}$ (1) Derate above 25°C	P_D	146 0.83	Watts $\text{W}/^\circ\text{C}$
Storage Temperature Range	T_{stg}	-65 to +200	$^\circ\text{C}$

THERMAL CHARACTERISTICS

Characteristic	Symbol	Max	Unit
Thermal Resistance, Junction to Case	$R_{\theta JC}$	1.2	$^\circ\text{C}/\text{W}$

ELECTRICAL CHARACTERISTICS* ($T_C = 25^\circ\text{C}$ unless otherwise noted.)

Characteristic	Symbol	Min	Typ	Max	Unit
----------------	--------	-----	-----	-----	------

OFF CHARACTERISTICS

Collector-Emitter Breakdown Voltage ($I_C = 50 \text{ mAdc}$, $I_B = 0$)	$V_{(BR)CEO}$	33	—	—	Vdc
Collector-Emitter Breakdown Voltage ($I_C = 50 \text{ mAdc}$, $V_{BE} = 0$)	$V_{(BR)CES}$	60	—	—	Vdc
Emitter-Base Breakdown Voltage ($I_E = 5.0 \text{ mAdc}$, $I_C = 0$)	$V_{(BR)EBO}$	4.0	—	—	Vdc
Collector Cutoff Current ($V_{CB} = 30 \text{ Vdc}$, $I_E = 0$)	I_{CBO}	—	—	2.0	mAdc

NOTE:

(continued)

1. These devices are designed for RF operation. The total device dissipation rating applies only when the devices are operated as RF amplifiers.

* Indicates JEDEC Registered Data.

ELECTRICAL CHARACTERISTICS* — continued ($T_C = 25^\circ\text{C}$ unless otherwise noted.)

Characteristic	Symbol	Min	Typ	Max	Unit
ON CHARACTERISTICS					
DC Current Gain ($I_C = 1.0\text{ Adc}$, $V_{CE} = 5.0\text{ Vdc}$)	h_{FE}	10	—	100	—

DYNAMIC CHARACTERISTICS

Output Capacitance ($V_{CB} = 28\text{ Vdc}$, $I_E = 0$, $f = 1.0\text{ MHz}$)	C_{ob}	—	67	75	pF
---	----------	---	----	----	----

BROADBAND FUNCTIONAL TESTS (Figure 6)

Common-Emitter Amplifier Power Gain ($V_{CC} = 28\text{ Vdc}$, $P_{out} = 60\text{ W}$, $f = 225\text{--}400\text{ MHz}$)	G_{PE}	7.8	8.5	—	dB
Electrical Ruggedness ($P_{out} = 60\text{ W}$, $V_{CC} = 28\text{ Vdc}$, $f = 400\text{ MHz}$, VSWR 30:1 all phase angles)	ψ	No Degradation in Output Power			—

NARROW BAND FUNCTIONAL TESTS (Figure 1)

Common-Emitter Amplifier Power Gain ($V_{CC} = 28\text{ Vdc}$, $P_{out} = 60\text{ W}$, $f = 400\text{ MHz}$)	G_{PE}	7.8	10	—	dB
Collector Efficiency ($V_{CC} = 28\text{ Vdc}$, $P_{out} = 60\text{ W}$, $f = 400\text{ MHz}$)	η	55	—	—	%

* Indicates JEDEC Registered Data.

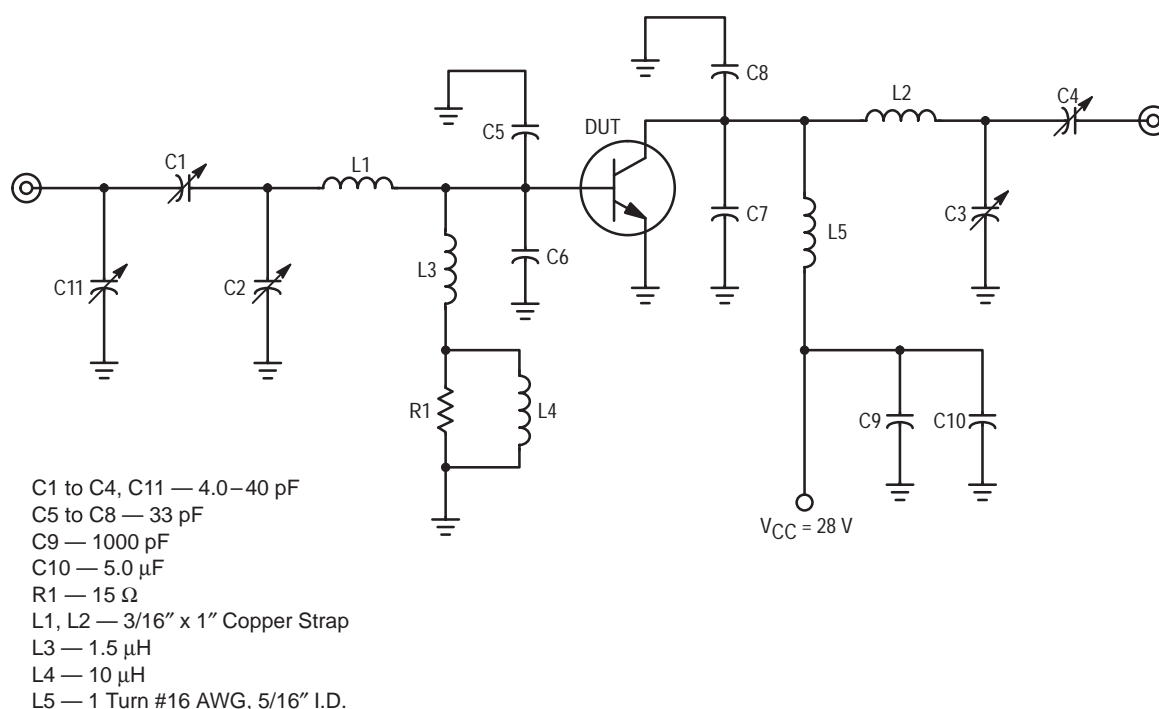

Figure 1. 400 MHz Test Amplifier (Narrow Band)

LIFETIME BUY

LAST SHIP 06/07/00 LAST ORDER 06/01/00

NARROW BAND DATA

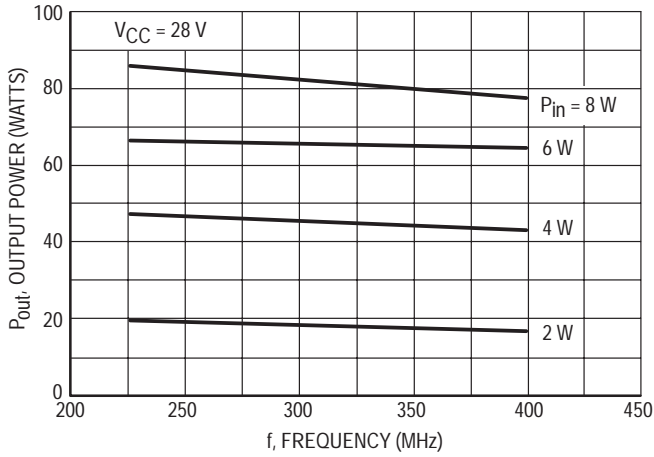

Figure 2. P_{out} versus Frequency

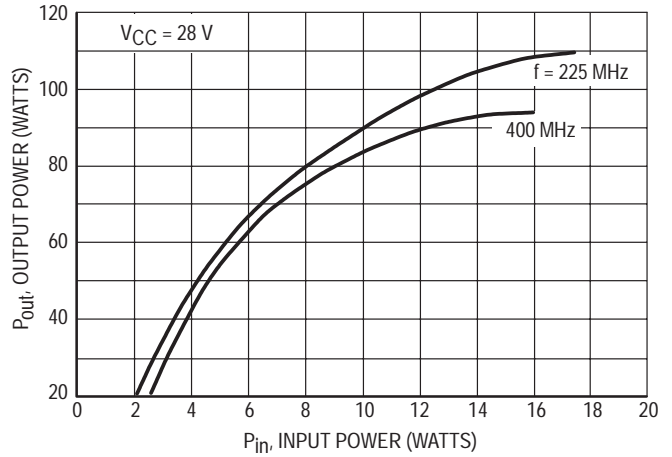

Figure 3. Output Power versus Input Power

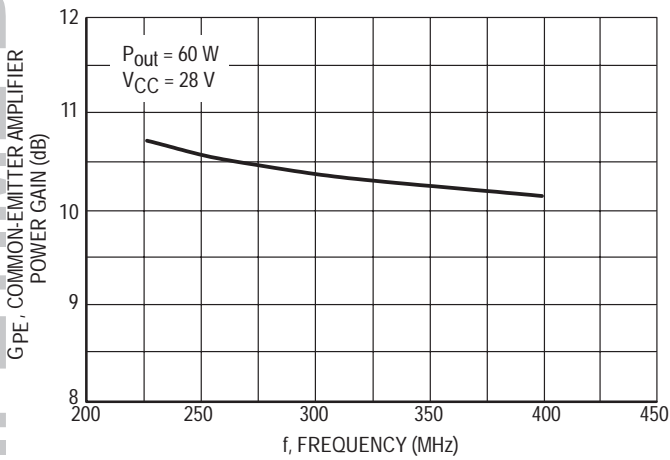

Figure 4. Power Gain versus Frequency

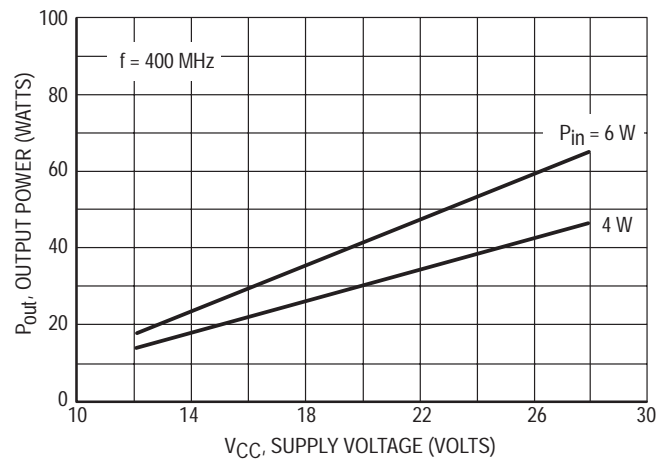

Figure 5. Output Power versus Supply Voltage

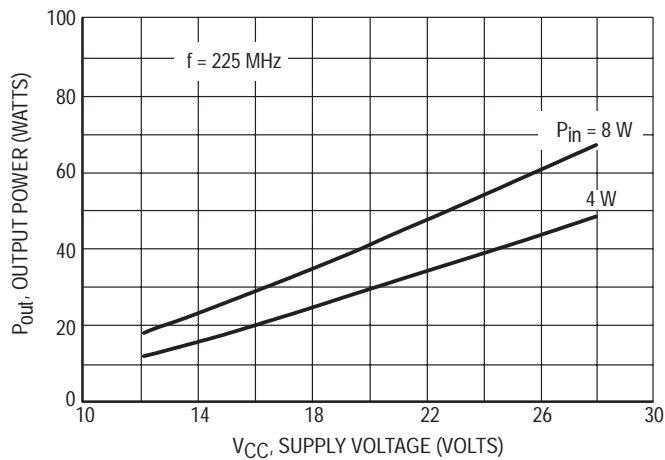
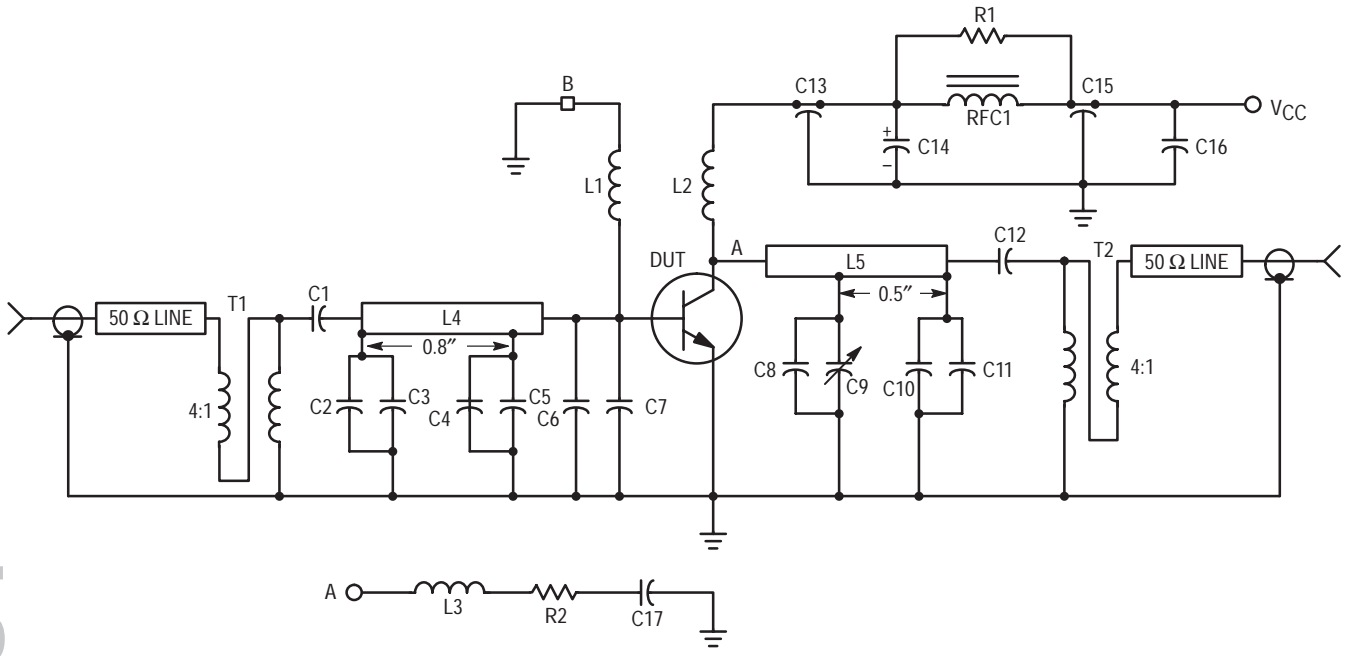

Figure 6. Output Power versus Supply Voltage

LIFETIME BUY

LAST SHIP 06/07/00 LAST ORDER 06/01/00



- C1 — 68 pF
- C2, C4, C8, C10 — 27 pF
- C3, C5, C11 — 10 pF
- C6, C7 — 51 pF
- C9 — 1.0–10 pF JOHANSON
- C12 — 100 pF
- C13, C15 — 680 pF
- C14, C16 — 1.0 μ F, 35 V Tantalum
- C17 — 0.1 μ F, ERIE Red Cap
- RFC1 — Ferrite Bead Choke, Ferroxcube VK200 19/4B
- B — Ferroxcube 56-590-65/4B Ferrite Bead
- T1, T2 — 25 Ohms (UT25) Miniature Coaxial Cable, 1 turn
- R1 — 11 Ω , 1.0 W
- R2 — 20 Ω , 1/4 W
- L1 — 10 Turns, #22 AWG, 1/8" I.D.
- L2 — 4 Turns, #16 AWG, 1/4" I.D.
- L3 — 6 Turns, #24 AWG, 1/8" I.D.
- L4, L5 — 1" x 0.25" Microstrip Line
Board Material 0.031" Thick Teflon-Fiberglass

Figure 7. 225 to 400 MHz Broadband Test Circuit Schematic

BROADBAND DATA (Circuit, Figure 7)

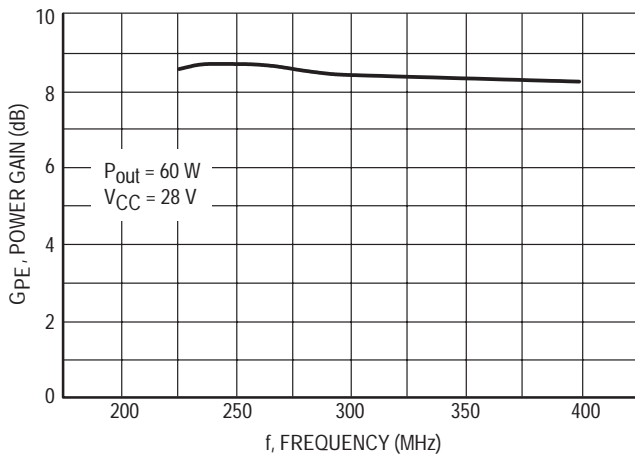

Figure 8. Power Gain versus Frequency

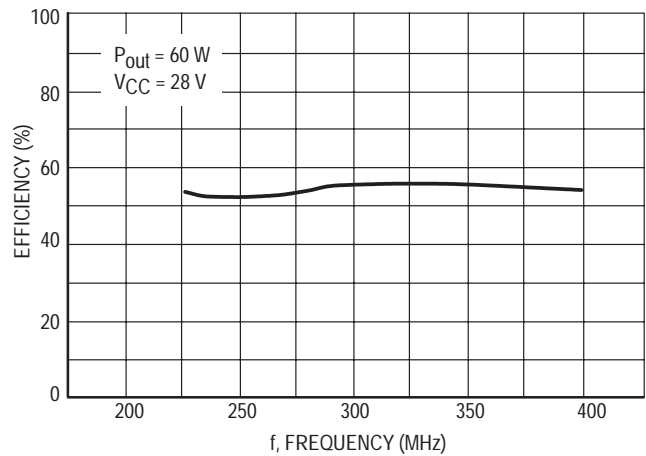

Figure 9. Efficiency versus Frequency

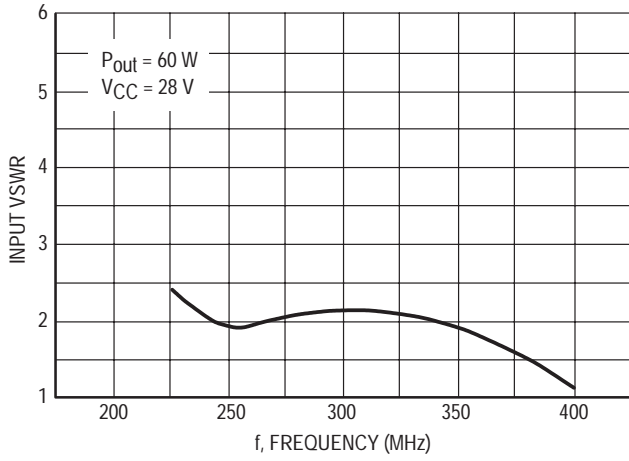

Figure 10. Input VSWR versus Frequency

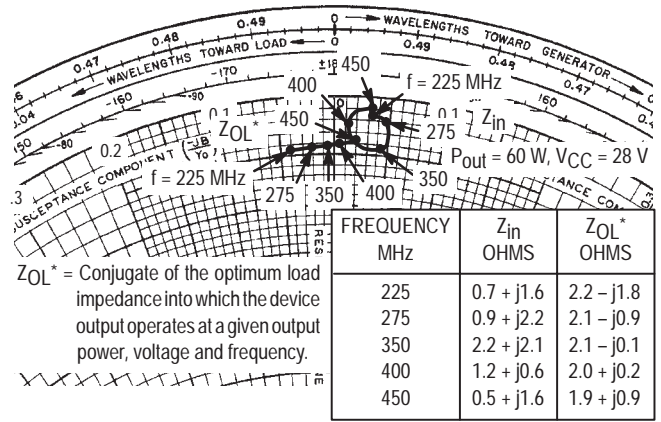
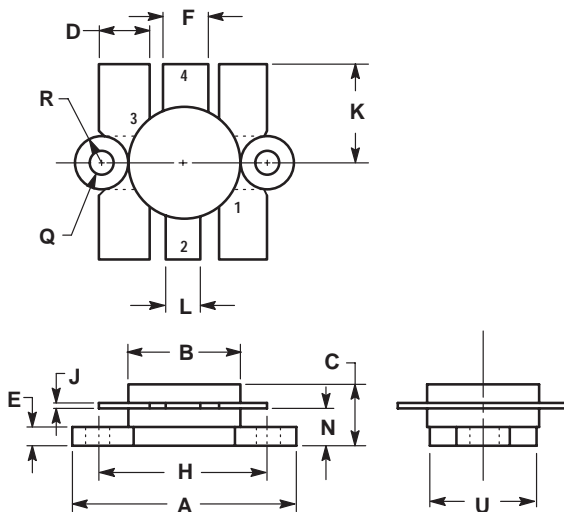

Figure 11. Series Equivalent Input-Output Impedance

PACKAGE DIMENSIONS



NOTES:
1. FLANGE IS ISOLATED IN ALL STYLES.

DIM	INCHES		MILLIMETERS	
	MIN	MAX	MIN	MAX
A	24.38	25.14	0.960	0.990
B	12.45	12.95	0.490	0.510
C	5.97	7.62	0.235	0.300
D	5.33	5.58	0.210	0.220
E	2.16	3.04	0.085	0.120
F	5.08	5.33	0.200	0.210
H	18.29	18.54	0.720	0.730
J	0.10	0.15	0.004	0.006
K	10.29	11.17	0.405	0.440
L	3.81	4.06	0.150	0.160
N	3.81	4.31	0.150	0.170
Q	2.92	3.30	0.115	0.130
R	3.05	3.30	0.120	0.130
U	11.94	12.57	0.470	0.495

STYLE 1:
PIN 1. EMITTER
2. COLLECTOR
3. EMITTER
4. BASE

CASE 316-01
ISSUE D

LIFETIME BUY

LAST SHIP 06/07/00
LAST ORDER 06/01/00

Motorola reserves the right to make changes without further notice to any products herein. Motorola makes no warranty, representation or guarantee regarding the suitability of its products for any particular purpose, nor does Motorola assume any liability arising out of the application or use of any product or circuit, and specifically disclaims any and all liability, including without limitation consequential or incidental damages. "Typical" parameters can and do vary in different applications. All operating parameters, including "Typicals" must be validated for each customer application by customer's technical experts. Motorola does not convey any license under its patent rights nor the rights of others. Motorola products are not designed, intended, or authorized for use as components in systems intended for surgical implant into the body, or other applications intended to support or sustain life, or for any other application in which the failure of the Motorola product could create a situation where personal injury or death may occur. Should Buyer purchase or use Motorola products for any such unintended or unauthorized application, Buyer shall indemnify and hold Motorola and its officers, employees, subsidiaries, affiliates, and distributors harmless against all claims, costs, damages, and expenses, and reasonable attorney fees arising out of, directly or indirectly, any claim of personal injury or death associated with such unintended or unauthorized use, even if such claim alleges that Motorola was negligent regarding the design or manufacture of the part. Motorola and (M) are registered trademarks of Motorola, Inc. Motorola, Inc. is an Equal Opportunity/Affirmative Action Employer.

Literature Distribution Centers:

USA: Motorola Literature Distribution; P.O. Box 20912; Phoenix, Arizona 85036.
 EUROPE: Motorola Ltd.; European Literature Centre; 88 Tanners Drive, Blakelands, Milton Keynes, MK14 5BP, England.
 JAPAN: Nippon Motorola Ltd.; 4-32-1, Nishi-Gotanda, Shinagawa-ku, Tokyo 141, Japan.
 ASIA PACIFIC: Motorola Semiconductors H.K. Ltd.; Silicon Harbour Center, No. 2 Dai King Street, Tai Po Industrial Estate, Tai Po, N.T., Hong Kong.



2N6439/D

