

POWER

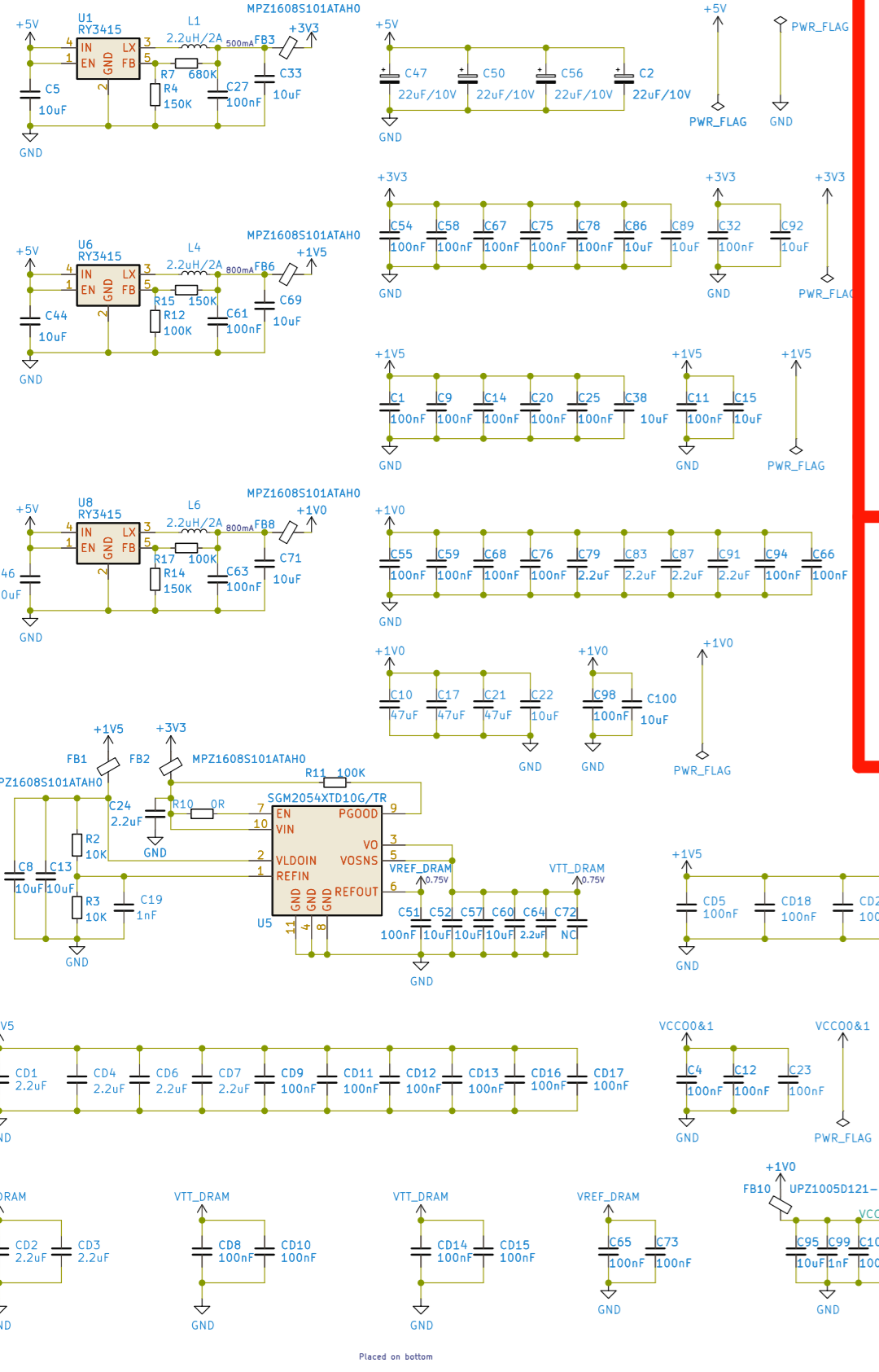

GW2A-LV18PG256C8I7

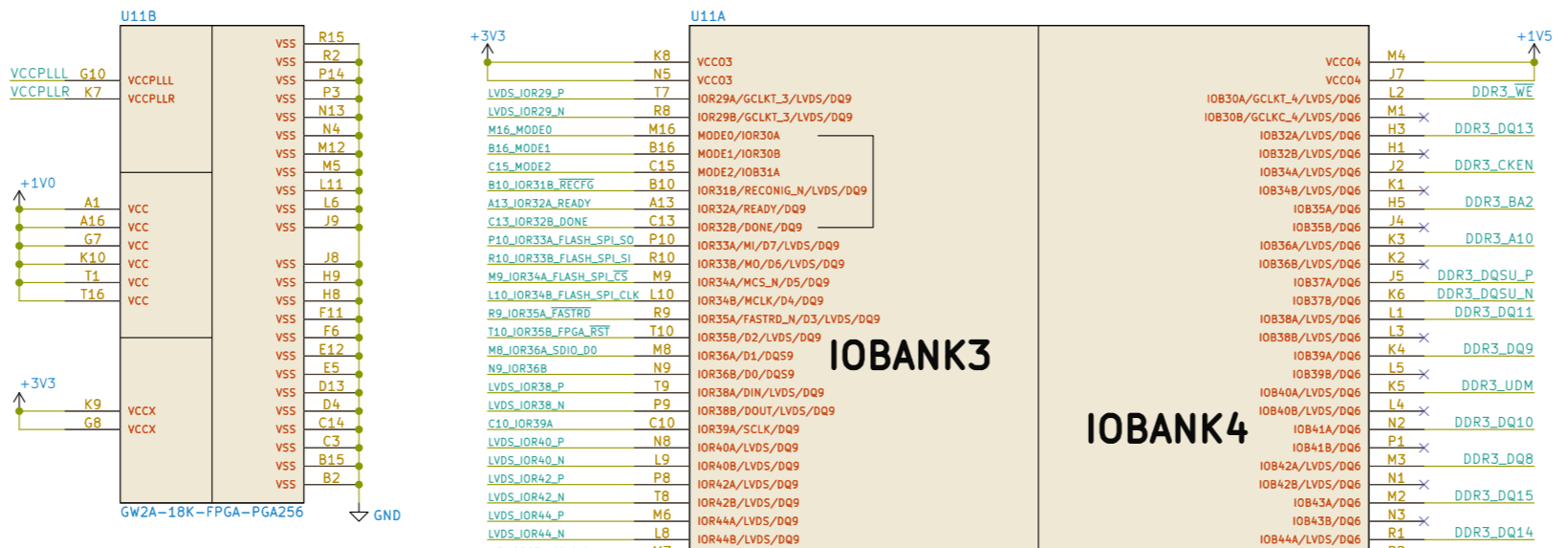

DDR3 128Meg x16

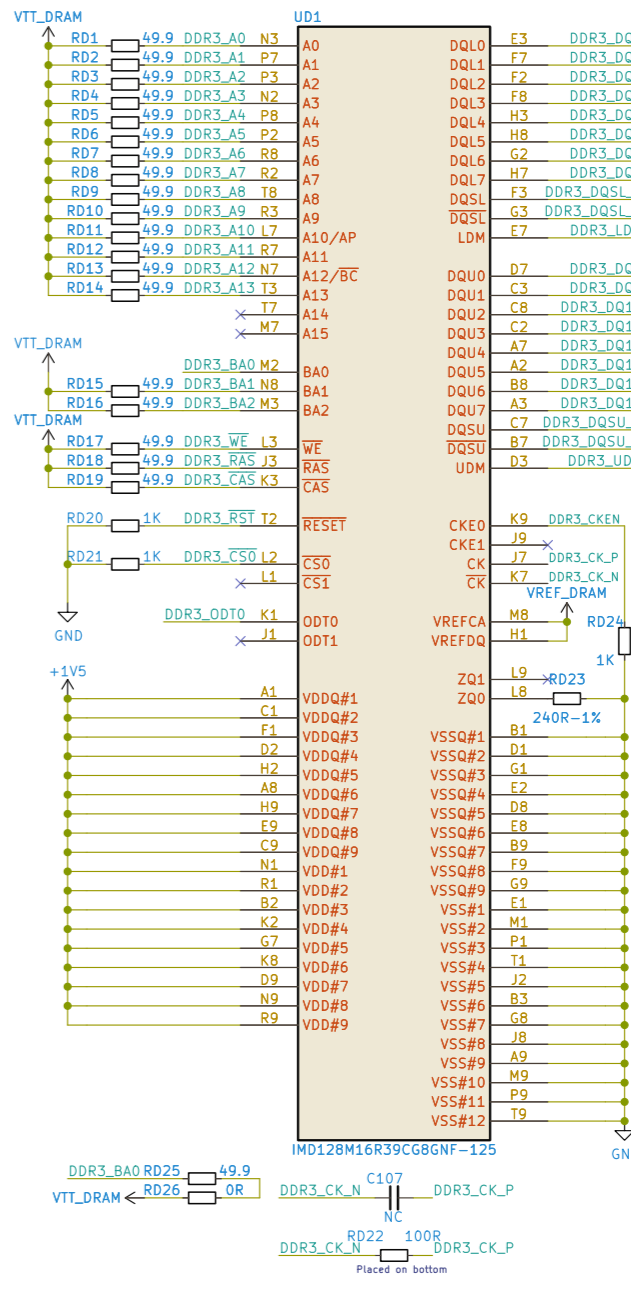

TEST POINTS

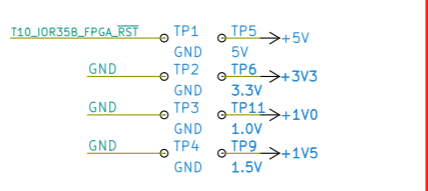

IOBANK2

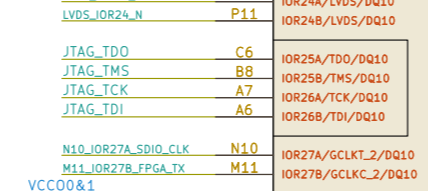

IOBANK5

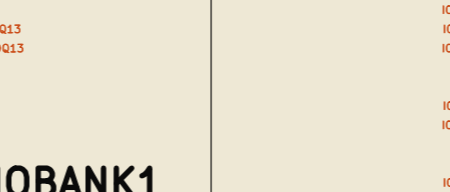

IOBANK1

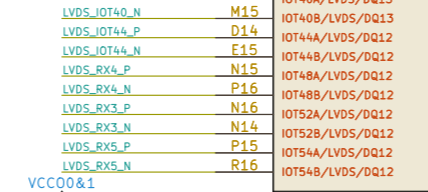

IOBANK6

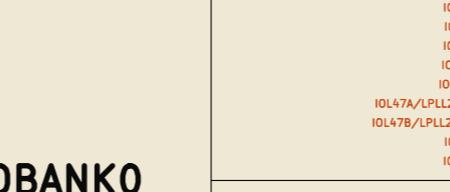

IOBANK0

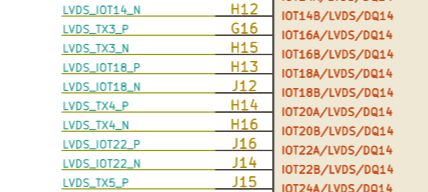

IOBANK7

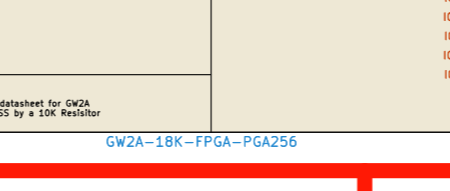

204P SODIMM GOLDEN FINGER

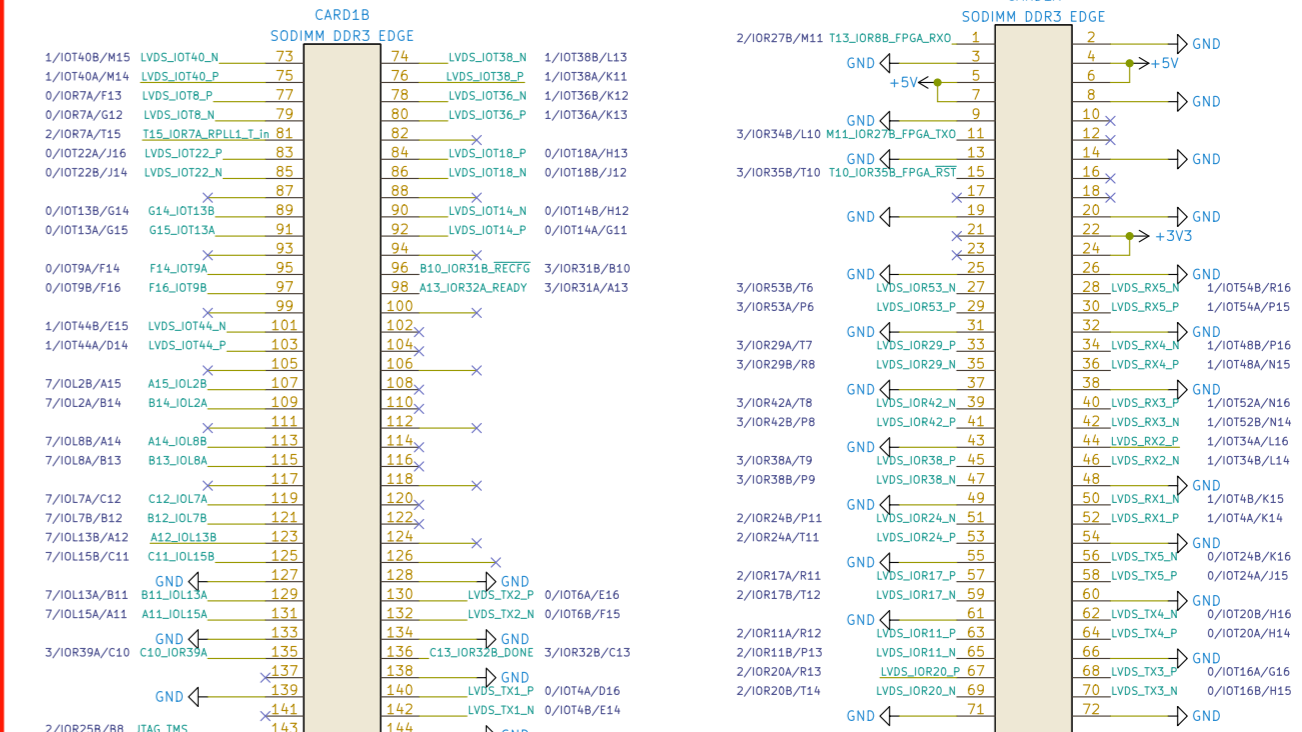

RST

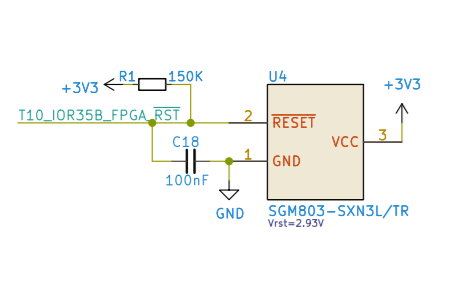

SPI LCD Conn.

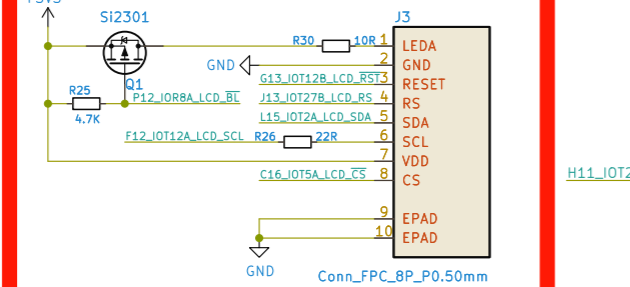

OSCILLATOR

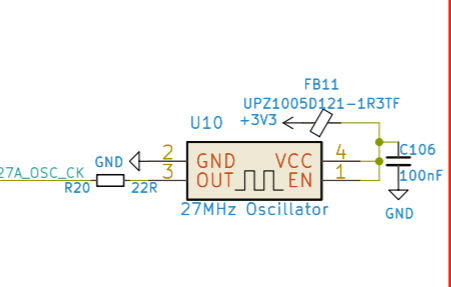

microSD Card/SDIO

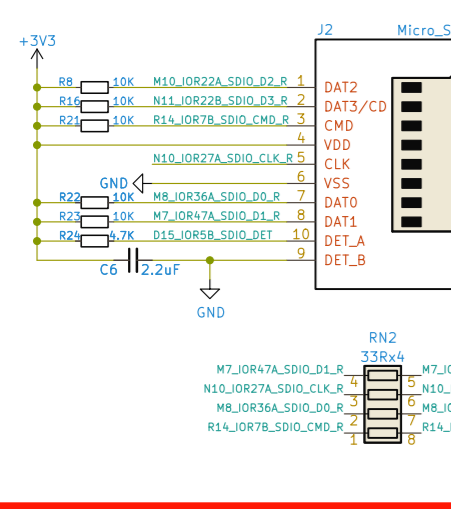

SPI FLASH

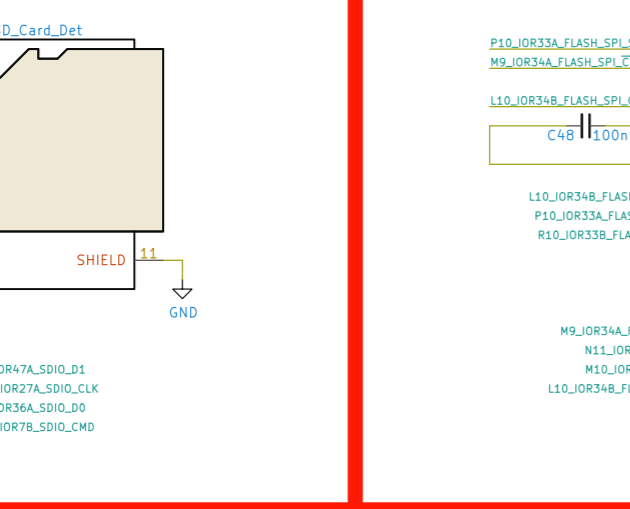

MODE & CONFIG

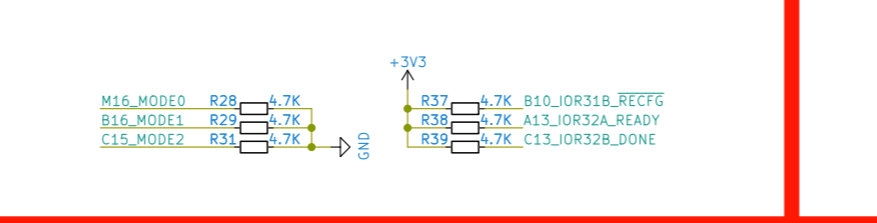

JTAG & UART

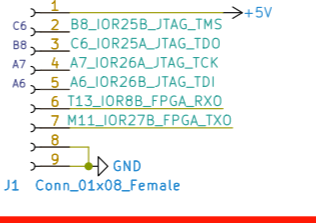

IO STUB RESISTORS

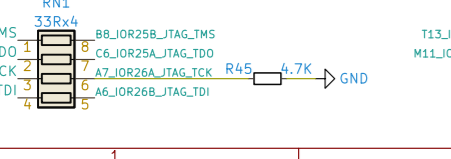

OPT. IOBANK VOLTAGE SELECT

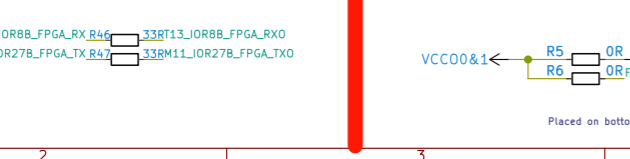

LVDS TERMINATION RES.

