

LEVEL SHIFTING SIGNALS WITH DIFFERENTIAL AMPLIFIERS

by David Jones, (602) 746-7696

The INA105 is a unity gain differential amplifier consisting of a premium grade operational amplifier and an on-chip precision resistor network. The self-contained INA105 makes it ideal for many applications. One such application is precision level shifting.

Figure 1 shows a general case of a unity gain differential amplifier that performs a signal level shift proportional to the voltage V_{SHIFT} appearing on pin 3 of the OPA27. An operational amplifier is used to drive the INA105's "Ref" pin (pin 1) with a low impedance source to preserve true differential operation of the INA105.

A basic understanding of the circuit operation can be gained by considering the INA105 as a three input summing amplifier. The voltage transfer function is then $E_{OUT} = E_2 - E_1 + V_{REF}$. As this relation shows, the output will respond to a difference signal and algebraically add the voltage at the

"Ref" input. Therefore, V_{REF} may take on any arbitrary value that will not saturate the INA105 amplifier's output. In the case of the circuit in Figure 1, $V_{REF} = V_{SHIFT}$, yielding an output of $E_O = E_2 - E_1 + V_{SHIFT}$.

Precision fixed level shifting can be easily accomplished by the use of a voltage reference source such as the REF102. A REF102 used with an additional INA105 can be used to provide an accurate, low drift, +5V reference to drive the "Ref" pin of the differentially connected INA105 as shown in Figure 2. If, for example, the input signal is a bipolar $\pm 5V$ signal, the output will be level shifted to a unipolar 0-10V signal. The same reference circuit also has $-5V$ available and may thus be used for the opposite conversion from unipolar 0-10V to bipolar $\pm 5V$ signals. (Request PDS-1018 for INA105 and PDS-900 for REF102.)

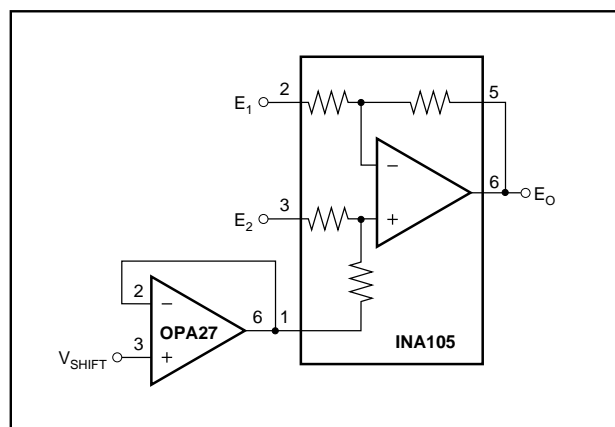

FIGURE 1. Level Shifting Circuit Using the INA105's V_{REF} Pin.

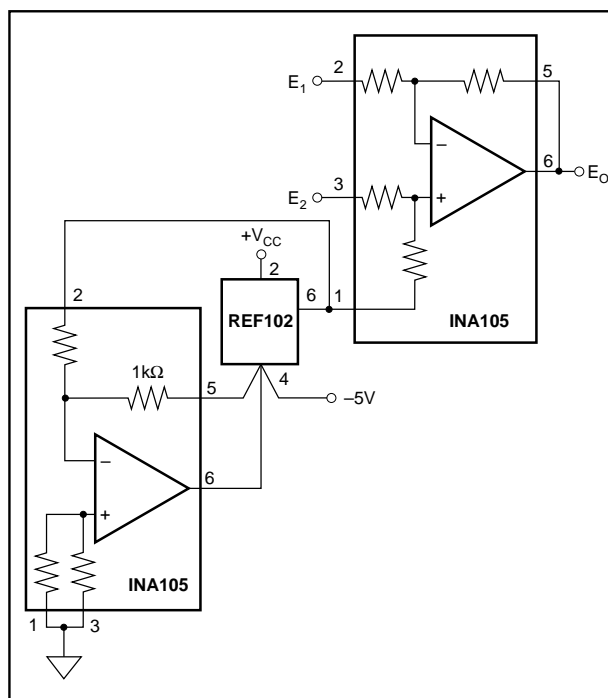

FIGURE 2. Precision Level Shift Circuit from a Fixed Voltage Reference.