

THE MPC100 ANALOG MULTIPLEXER IMPROVES RF SIGNAL DISTRIBUTION

By Christian Henn

When designing high-performance systems for RF and video applications requiring amplifiers, multiplexers, DC restoration circuits, switched and continuous multipliers, or programmable gain amplifiers, finding the right component to do the job is not easy. The new 4 to 1 video multiplexer MPC100 opens the door to high-speed signal distribution without the headaches. This component contains four wideband open-loop amplifiers connected together internally at the output with a bandwidth of 180MHz at 1.4Vp-p signal swing. When the user selects one channel by applying a digital "1" to the corresponding SEL input (see Figure 1), the component acts as a buffer amplifier with a high input impedance of $0.88M\Omega || 1pF$ and a low output impedance of 11Ω .

The MPC100 can be used to design a bus-controlled distribution field, as shown in Figure 3. In this application, a driver device, which is controlled by a memory and a parallel-to-serial converter, shifts the information about the field state into the output latches, U_1 , U_2 , and U_3 . When the strobe line is triggered the new latch information is stored in the output latches, which controls whether the buffers of the MPC100 (U_4 - U_9) are in an "on" or "off" state. The MPC100 operates with a fast make-before-break switching action to keep the output switching transients small and short. As shown in Figure 2, the switching time from one channel to the next is less than $0.5\mu s$, and the signal envelope during transition rises and falls symmetrically and shows practically no overshoot or DC settling effects. A transmission

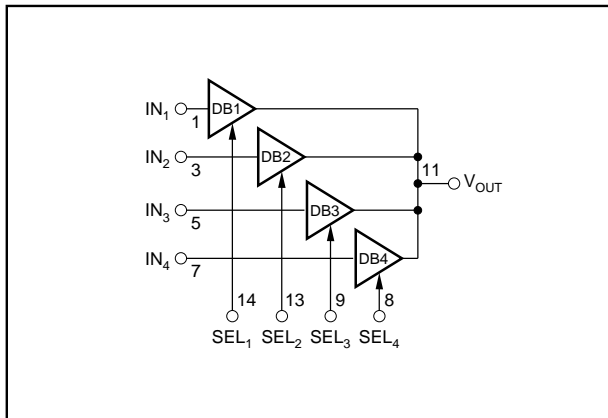

FIGURE 1. MPC100 Wide Bandwidth 4 X 1 Video Multiplexer.

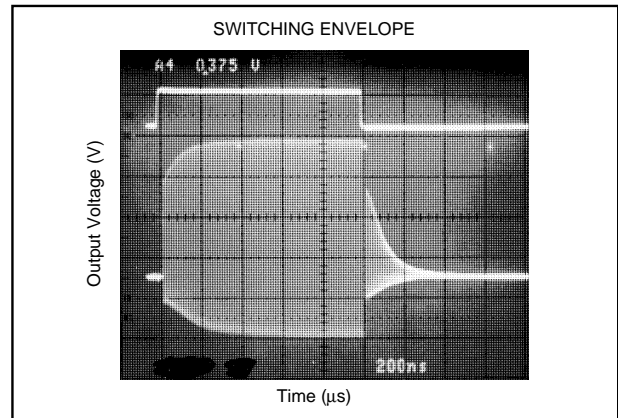

FIGURE 2. Switching Time from Channel to Channel of the MPC100.

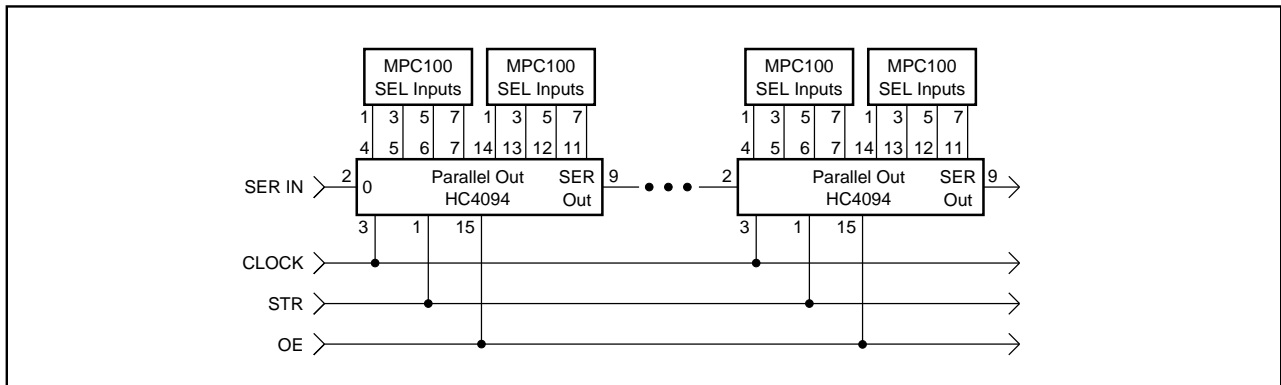

FIGURE 3. Serial Bus-controlled Distribution Field Using the MPC100.

rate of up to several MHz ensures control during the vertical blanking line, even in huge crosspoint fields.

Figure 4 shows the MPC100 used in a digitally controlled amplitude control system. With one MPC100, it is possible to perform four amplitude steps. Two MPC100s will perform eight steps. The R/2R ladder network used in this application varies the output swing by a factor of two when switching from one channel to the other, the highest gain being $G = 1$. The BUF600 decouples the RF input and drives the resistor network, which is connected from the amplifier's output to ground. The taps of the ladder network are tied to the channel inputs of the MPC100. A 74HC237 decoder controls the channel selection. As illustrated in the truth

table in Figure 4, a two-bit logic can vary the amplitude of the RF signal at the output of the subsequent OPA621 within less than $0.5\mu\text{s}$ from a gain of zero when all channels are off to gain of two when DB1 is selected. The digital amplitude control can easily be combined with an AGC amplifier. The MPC100 sets the rough range and the AGC circuit the fine tuning.

The MPC100 is available in a 14-pin plastic DIP or plastic SOIC package. Other performance highlights are low inter-channel crosstalk ($<60\text{dB}$ in SO package), a low differential gain of 0.05%, low phase errors of 0.01 degrees, a low quiescent current of $\pm 230\mu\text{A}$ when no channel is selected.

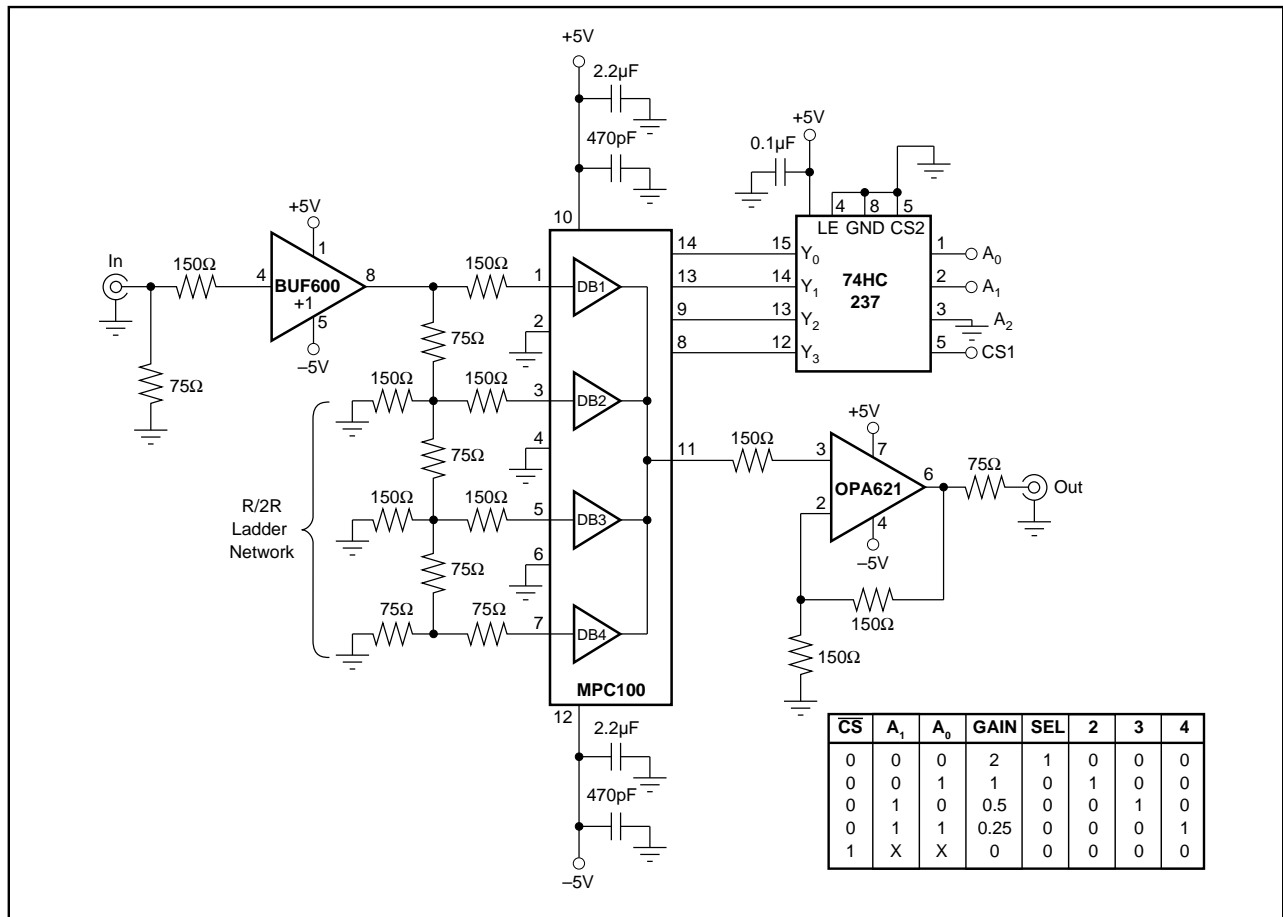

FIGURE 4. Digital Gain Control Circuit Using the MPC100.