



DTMF Generator

Features

- Generation of Sine Waves Using PWM (Pulse-Width Modulation)
- Combine Different Sine Waves to DTMF Signal
- AT94K Top-Module Design
- 260 Bytes Code Size and 128 Bytes Constants Table Size
- Use of Look-Up Tables

Introduction

This application note describes how Dual-Tone Multiple Frequencies (DTMF) signaling can be implemented using the FPSLIC™ embedded AVR® microcontroller with PWM and SRAM. Applications such as phones are using DTMF signals for transmitting dialing information. There are two frequencies added together to generate a valid DTMF signal, a low frequency (f_b) and a high frequency (f_a). Table 1 shows how the different frequencies are mixed to form DTMF tones. The Assembly code with the DTMF Generator routines can be found in the FPSLIC Software section of the Atmel web site (<http://www.atmel.com>), under the **2816.asm** archive.

Figure 1. DTMF Generator

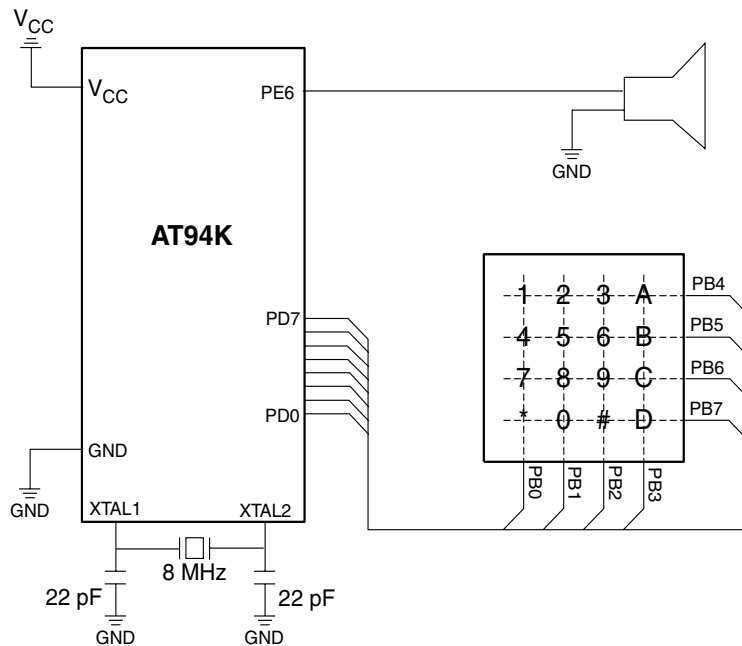

Programmable
SLI
AT94K
AT94S

Application Note



Table 1. DTMF Tone Matrix

| fb/fa | 1209 Hz | 1336 Hz | 1477 Hz | 1633 Hz |
|--------|---------|---------|---------|---------|
| 697 Hz | 1 | 2 | 3 | A |
| 770 Hz | 4 | 5 | 6 | B |
| 852 Hz | 7 | 8 | 9 | C |
| 941 Hz | * | 0 | # | D |

The rows of the matrix shown in Table 1 represent the low frequencies while the columns represent the high frequency values. For example, this matrix shows that digit 5 is represented by a low frequency of $f_b = 770$ Hz and a high frequency of $f_a = 1336$ Hz. The two frequencies are transformed to a DTMF signal using equation 1:

$$f(t) = A_a \sin(2\pi f_a t) + A_b \sin(2\pi f_b t) \quad (1)$$

where the ratio between the two amplitudes should be:

$$A_b/A_a = K \quad 0,7 < K < 0,9 \quad (2)$$

Theory of Operation

Starting from a general overview about the usage of the PWM, it will be shown how the PWM allows to generate Sine waves. In the next step, an introduction is given in how frequencies that are different from the ground frequency of the PWM can be generated. After closing the theoretical introduction with the DTMF signal itself, the implementation will be described.

Generating Sine Waves

According to the relation between high level and low level at the output pin of the PWM, the average voltage at this pin varies. Keeping the relation between both levels constant generates a constant voltage level. Figure 2 shows the PWM output signal.

Figure 2. Generation of a Constant Voltage Level

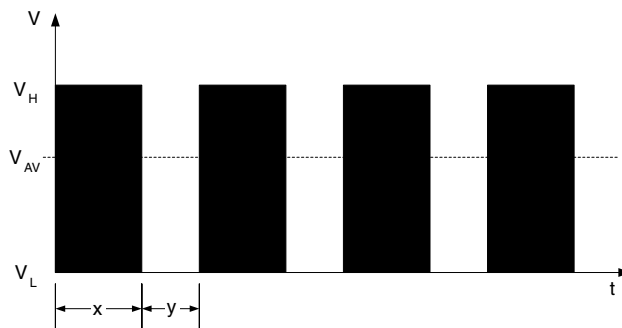

Equation 3 shows how to calculate the voltage level:

$$V_{AV} = \frac{xV_H + yV_L}{x + y} \quad (3)$$

A sine wave can be generated if the average voltage generated by the PWM is changed every PWM cycle. The relation between high and low level has to be adjusted according to the voltage level of the sine wave at the respective time. Figure 3 visualizes this scheme. The values for adjusting the PWM can be calculated every PWM cycle or stored in a look-up table (LUT).

Figure 3 also shows the dependency between frequency of the ground sine wave and the amount of samples. The more samples (N_c) are used, the more accurate the output signal gets. At the same time the frequency sinks. Equation 4 shows this correlation:

$$f = \frac{f_l}{N_c} = \frac{f_{CK}/510}{N_c} \quad (4)$$

- f: Sine wave frequency (1/T)
- f_l : PWM frequency ($f_{CK} / 510$)
- T: Period of ground sine wave
- f_{CK} : Timer Clock
- N_c : Number of samples (12 in Figure 3)

The PWM frequency is dependent on the PWM resolution. For an 8-bit resolution, the Timer TOP value is 0xFF (255). Because the timer counts up and down this value has to be doubled. In dividing the Timer Clock f_{CK} by 510 the PWM frequency can be calculated. According to this coherence a Timer Clock of 8 MHz generates a PWM frequency of 15.6 kHz.

Modifying the Frequency of the Sine Wave

Figure 3. Generating a Sine Wave with PWM

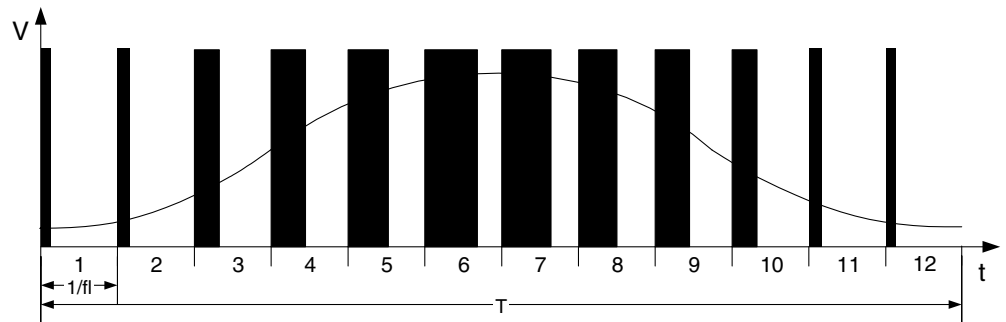

The sinusoid samples for adjusting the PWM are not read in a sequentially manner from the look-up table (LUT), but just every second value. At the same sample frequency an output signal with twice the frequency is generated, see Figure 4.

Figure 4. Doubling the Output Frequency ($X_{SW} = 2$)

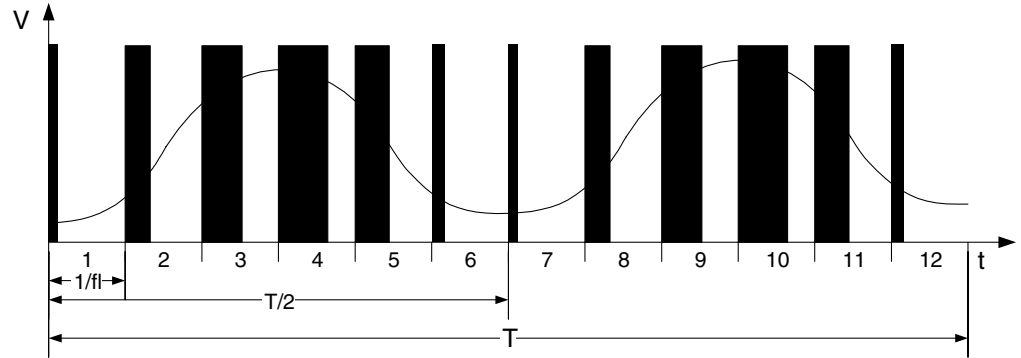

In using not every second sample but every third, fourth, fifth... it is possible to generate N_c different frequencies in the range from $[1/T \text{ Hz} .. 0 \text{ Hz}]$.

Note: For high frequencies it will not be a sine wave anymore.

The step-width between samples is specified by X_{SW} . Equation 5 describes this relation:

$$X_{SW} = f \frac{N_c}{f_l} = \frac{f N_c 510}{F_{CK}} \quad (5)$$

Equation 6 shows how to calculate the value with which the PWM has to be adjusted every PWM cycle (Timer overflow). Based on the value of the previous cycle (X'_{LUT}) the new value (X_{LUT}) is calculated in adding the step-width (X_{SW}).

$$X_{LUT} = X'_{LUT} + X_{SW} \quad (6)$$

X'_{LUT} : Old position in look-up table

X_{LUT} : New position in look-up table

Adding the Two Different Frequencies to a DTMF Signal

A DTMF signal has to be generated according to equations (1) and (2). Since this is easy to obtain with simple shift register operations a K-Factor of $K = 3/4$ has been chosen. Equation 6 shows how to calculate the look-up table position for adjusting the PWM.

$$f(X_{LUT}) = f(X_{LUTa}) + \frac{3}{4}f(X_{LUTb}) \quad (7)$$

with

$$X_{LUTa} = X'_{LUTa} + X_{SWa}$$

$$X_{LUTb} = X'_{LUTb} + X_{SWb}$$

$$f(X_{LUT}) = f(X'_{LUTa} + X_{SWa}) + \frac{3}{4}f(X'_{LUTb} + X_{SWb}) \quad (8)$$

Implementation of the DTMF Generator

In this application a DTMF tone generator is built using one of the 8-bit PWM outputs (OC1A) and a sinusoid table with $N_c = 128$ samples each with $n = 7$ bits. The following equations show this dependency and shows how the elements of the LUT are calculated:

$$f(x) = 63 + 63 \times \sin\left(\frac{2\pi x}{128}\right) \quad x \in [0 \dots 127] \quad (9)$$

The advantage in using 7 bits is that the sum of the high- and low-frequency signals fits in one byte. To support the whole DTMF tone set, we have to calculate eight X_{SW} values, one for each DTMF frequency, and place them in a table.

To achieve a higher accuracy, the following solution has been implemented: The X_{SW} values calculated after equation 5 need only five bytes. To use all eight bytes to have a lower rounding error, this value is multiplied by eight. The pointer to the look-up table is saved in the same manner. But here two bytes are needed to store the actual value times eight. This means that three right shifts and a module operation with N_c have to be executed before using them as pointers to the sine values in the look-up table. Equation 10 shows the complete dependencies:

$$X_{LUTa,b} = ROUND\left(\frac{1}{8}\left(X'_{LUTa,bExt} + \frac{8N_c f 510}{F_{CK}}\right)\right) \quad (10)$$

$X_{LUTa,b}$: Current position of element in LUT (actual format)

$X'_{LUTa,bExt}$: Previous position of element in LUT (extended format)

Figure 5. Schematics of the ATSTK94 Top-Module

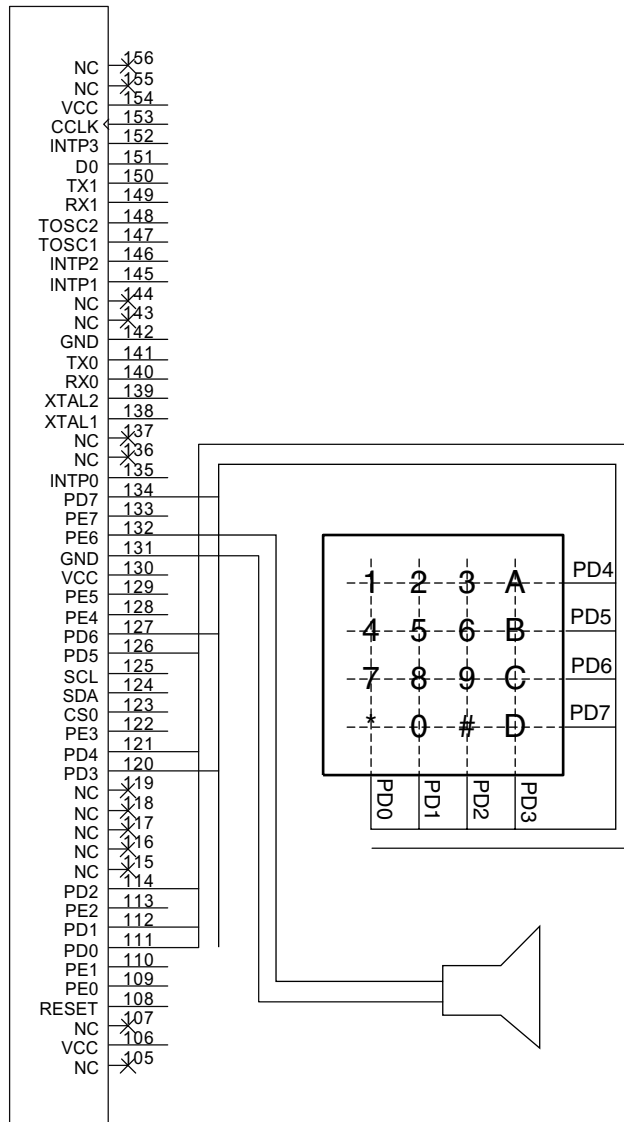

The PWM signal is put out on the OC1A pin (PE6). An additional output filter will help to achieve a good sinusoid. If the PWM frequency is decreased, it can be necessary to implement a steeper filter to obtain a good result.

The connection with the keypad is shown in Figure 1. The functionality of the keypad determines how the pressed key has to be evaluated. It has to be done in two steps:

1. Detecting the row of the pressed key
 - define low nibble of PORTD as output/zero value
 - define high nibble of PORTD as input/pull up
 - low bit in high nibble determines row
2. Detecting the column of the pressed key
 - define high nibble of PORTD as output/zero value
 - define low nibble of PORTD as input/pull up
 - low bit in low nibble determines column

Figure 6 visualizes the functionality of the routine to detect a pressed key. The pressed key conditions the step width value. The interrupt routine uses this values to calculate the PWM settings for the two Sine Waves of the DTMF tone. The interrupt routine is shown in Figure 7 and Figure 8.

The interrupt routine calculates the output compare value for the next PWM cycle. The interrupt routine first calculates the position of the next sample value in the LUT and read the value stored there.

The position of the sample in the LUT is determined by the step-width. The step-width itself is determined by the frequency which is to be generated.

Combining the sample values of the both DTMF frequencies using formula 7 gives the final output compare value of the PWM.

Figure 6. Main Function

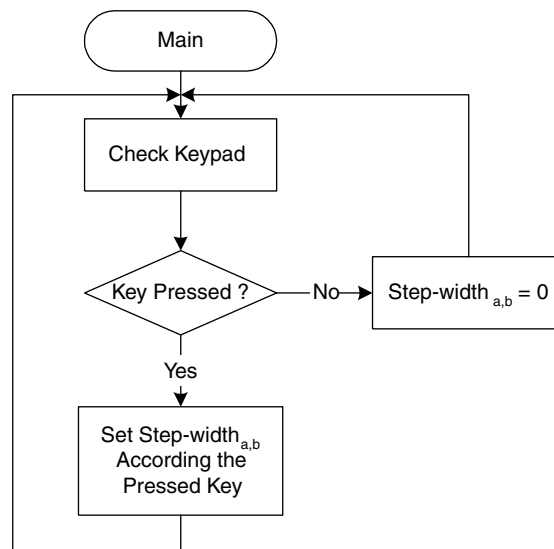

Figure 7. Interrupt Service Routine Timer Overflow

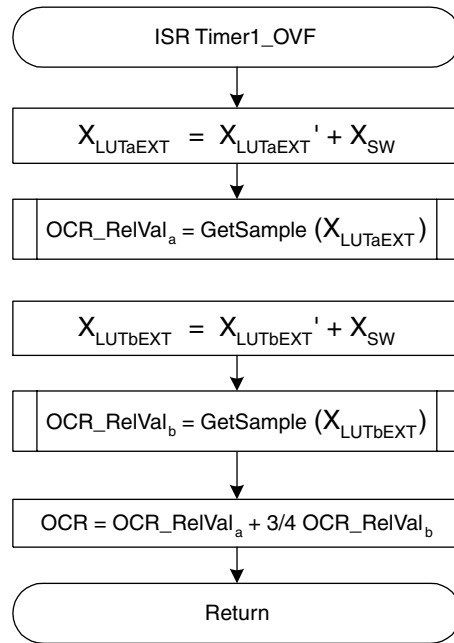
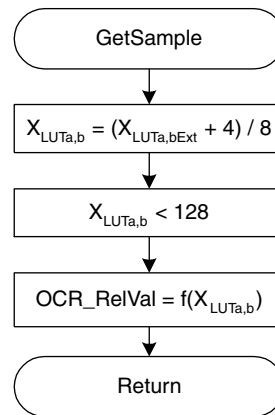

Figure 8. Function “GetSample”





Atmel Headquarters

Corporate Headquarters

2325 Orchard Parkway
San Jose, CA 95131
TEL 1(408) 441-0311
FAX 1(408) 487-2600

Europe

Atmel Sarl
Route des Arsenaux 41
Case Postale 80
CH-1705 Fribourg
Switzerland
TEL (41) 26-426-5555
FAX (41) 26-426-5500

Asia

Room 1219
Chinachem Golden Plaza
77 Mody Road Tsimhatsui
East Kowloon
Hong Kong
TEL (852) 2721-9778
FAX (852) 2722-1369

Japan

9F, Tonetsu Shinkawa Bldg.
1-24-8 Shinkawa
Chuo-ku, Tokyo 104-0033
Japan
TEL (81) 3-3523-3551
FAX (81) 3-3523-7581

Atmel Operations

Memory

2325 Orchard Parkway
San Jose, CA 95131
TEL 1(408) 441-0311
FAX 1(408) 436-4314

Microcontrollers

2325 Orchard Parkway
San Jose, CA 95131
TEL 1(408) 441-0311
FAX 1(408) 436-4314

La Chantrerie
BP 70602
44306 Nantes Cedex 3, France
TEL (33) 2-40-18-18-18
FAX (33) 2-40-18-19-60

ASIC/ASSP/Smart Cards

Zone Industrielle
13106 Rousset Cedex, France
TEL (33) 4-42-53-60-00
FAX (33) 4-42-53-60-01

1150 East Cheyenne Mtn. Blvd.
Colorado Springs, CO 80906
TEL 1(719) 576-3300
FAX 1(719) 540-1759

Scottish Enterprise Technology Park
Maxwell Building
East Kilbride G75 0QR, Scotland
TEL (44) 1355-803-000
FAX (44) 1355-242-743

RF/Automotive

Theresienstrasse 2
Postfach 3535
74025 Heilbronn, Germany
TEL (49) 71-31-67-0
FAX (49) 71-31-67-2340

1150 East Cheyenne Mtn. Blvd.
Colorado Springs, CO 80906
TEL 1(719) 576-3300
FAX 1(719) 540-1759

Biometrics/Imaging/Hi-Rel MPU/ High Speed Converters/RF Datacom

Avenue de Rochepleine
BP 123
38521 Saint-Egreve Cedex, France
TEL (33) 4-76-58-30-00
FAX (33) 4-76-58-34-80

Atmel Programmable SLI Hotline
(408) 436-4119

Atmel Programmable SLI e-mail
fpslic@atmel.com

FAQ
Available on web site

e-mail
literature@atmel.com

Web Site
<http://www.atmel.com>

© Atmel Corporation 2002.

Atmel Corporation makes no warranty for the use of its products, other than those expressly contained in the Company's standard warranty which is detailed in Atmel's Terms and Conditions located on the Company's web site. The Company assumes no responsibility for any errors which may appear in this document, reserves the right to change devices or specifications detailed herein at any time without notice, and does not make any commitment to update the information contained herein. No licenses to patents or other intellectual property of Atmel are granted by the Company in connection with the sale of Atmel products, expressly or by implication. Atmel's products are not authorized for use as critical components in life support devices or systems.

ATMEL® and AVR® are the registered trademarks of Atmel. FPSLIC™ is the trademark of Atmel.

Other terms and product names may be the trademarks of others.



Printed on recycled paper.